

VEVOR[®]

**SUBMERSIBLE PUMP FOR
DEEP-WELL
OPERATION MANUAL**

VEVOR[®]

SUBMERSIBLE PUMP FOR DEEP-WELL



NEED HELP? CONTACT US!

Have product questions? Need technical support? Please feel free to contact us:

CustomerService@vevor.com

This is the original instructions, please read all manual instructions carefully before operating. VEVOR reserves clear interpretation of our user manual. The appearance of the product shall be subject to the product you received. Please forgive us that we won't inform you again if there is any technology or software updates on our product.

Thank you for buying our water pumps.
Please read the operation manual carefully before using.

⚠ WARNING

- The reliable grounding must be conducted before using water pump. The earth leakage protective device as well as the overload or over-current protective device must be installed on water pump.
- The electric pump is not allowed for dry running.
- When the pump is in operation, people and animals shall not touch the water near the pump.
- In order to prevent electrical shock, the power source shall be shut off at maintenance and cleaning.
- Replacement power cord, Type Y connection-If the power cord is damaged, it must be replaced with a special flexible cord or a special component purchased from its manufacturer or maintenance department.

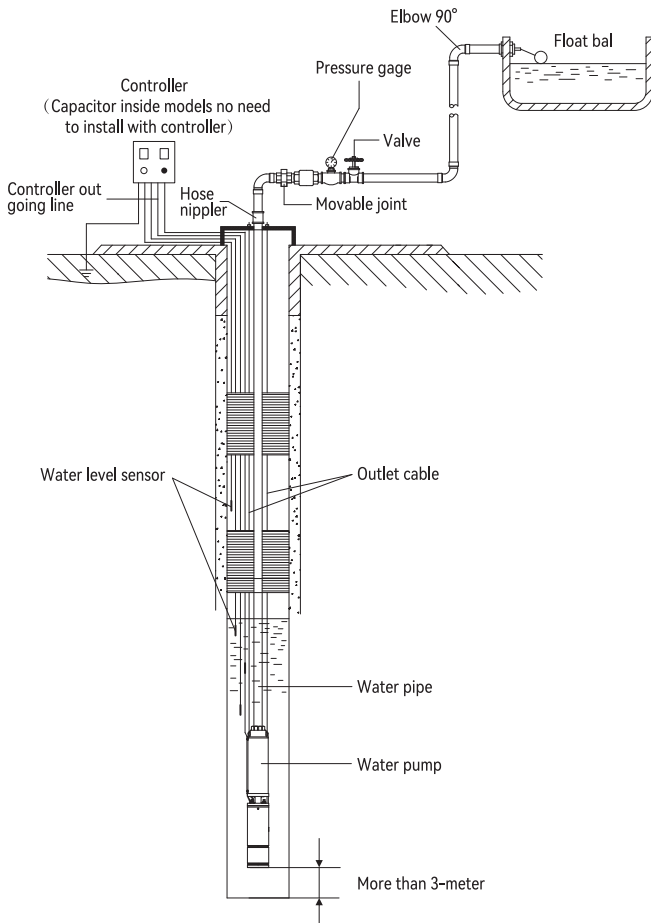

The above installation structure is for reference only. Please purchase the matching parts shown in the figure by yourself.

INTRODUCTION

The deep-well pump is a water lifting tool based on direct connection between electric machine and water pump, which is suitable for fetching underground water from deep wells, rivers, reservoirs and canals etc in some projects. Further, this product is mainly used for farmland irrigation as well as human and animal drinking water in plateau mountain areas. More importantly, the deep-well pump can be used for water supply and discharge in cities, factories, railways, mines and construction sites.

USE CONDITION

- 2.1 Voltage fluctuating range shall be $\pm 10\%$ of rated values;
- 2.2 The water temperature shall not be higher than $+35^{\circ}\text{C}$.
- 2.3 The PH value of water is between 6.5 and 8.5.
- 2.4 The solid contents in the water shall not be larger than 0.25% with the maximum diameter not over 2.3mm.

INSTALLATION USE AND NOTICE

- 3.1 Please check whether the inner diameter conforms to the minimum diameter of water pumps before buying and installing. If it is a new well, the air compressor or old water pump shall be used to clean sundries and soils. After that, please check whether the water quality and temperature conform to use conditions. The water pump can only be installed onto the water inside the well up to standard.
 - 3.2 Please check damage that may be caused in the transportation and storage process after unpacking the pump. For example, whether the cable and plug etc are intact; various joints are not loosened and without any leakage. If there has any damage, please contact with professional personnel to repair or replace it.
 - 3.3 During installation, please fix the electric pump and then install the earth leakage protective device or the over-heat or over-current protective device correctly. The electric pump must be connected to ground reliably.
 - 3.4 When the water pump reaches a certain length, the motor and the pump body need to be packed separately.
- In case of a separate packing, firstly remove the filter screen and the cable protection plate from the pump body (Figure1), then place the pump body on the motor to make the spindle head of the rotor smoothly slide into the coupling, manually rotate the coupling to check if it can run normally, then screw up the connecting bolt (Figure2), and finally install the filter screen and the cable protection plate (Figure3).

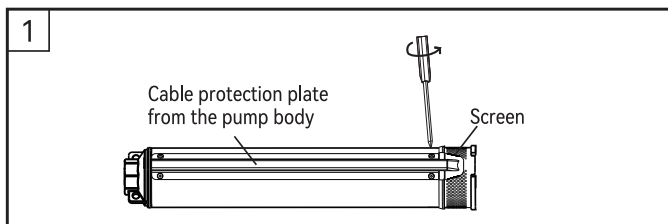

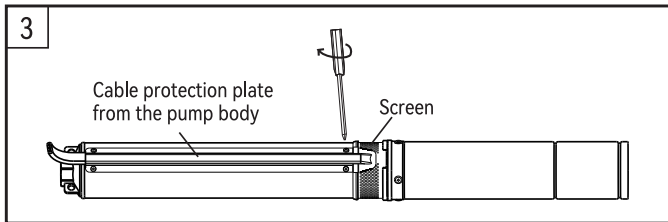
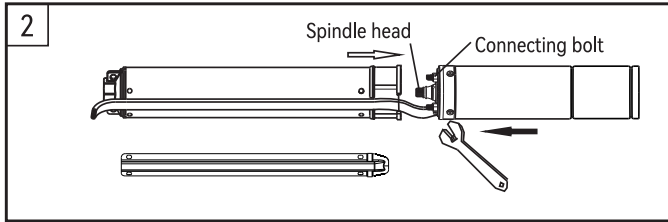

3.5 Before use, thoroughly test the insulation resistance of the electronic pump's stator winding (including outgoing cable) to the pump casing with a 500V megohmmeter, and the cold insulation resistance should be no less than 100 MΩ.

3.6 The electric pump shall be connected to the power source for trial operation before entering into water. The time shall not exceed 3 seconds. The cable lines of single-phase water pump shall be connected according to the wiring diagram on the electric machine or control cabinet strictly connected by correct colors. The wrong wiring will cause abnormal works or even damage the electric machine; three-phase water pump can be connected without differentiating cable colors.

3.7 A power line can be added with rather distant power supply. Please select proper cable lines according to table to avoid the cable too thin to be abnormal operation.

220-240V~ 50/60Hz

Single Phase Motor kW	Cable Length/Cross-sectional Area Of Conductor(mm ²)					
	0-15m	16-30m	31-45m	46-60m	61-75m	76-90m
0.25	0.75	0.75	0.75	0.75	1.0	1.25
0.37	0.75	0.75	0.75	1.0	1.25	1.25
0.55	0.75	0.75	1.0	1.25	1.25	1.5
0.75	0.75	1.0	1.25	1.25	1.5	1.5
0.92	1.0	1.25	1.25	1.5	1.5	2.0
1.1	1.0	1.25	1.5	1.5	2.0	2.0
1.5	1.25	1.5	2.0	2.0	2.5	2.5
1.8	1.5	2.0	2.0	2.5	2.5	3.0
2.2	1.5	2.0	2.5	2.5	3.0	4.0
2.6	2.0	2.5	2.5	3.0	4.0	4.0
3.0	2.0	2.5	3.0	4.0	4.0	5.0

115V~ 60Hz

Single Phase Motor kW	Cable Length/Cross-sectional Area Of Conductor(mm ²)					
	0-15m	16-30m	31-45m	46-60m	61-80m	81-100m
0.18	0.6	0.75	1.0	1.25	1.5	2.0
0.25	0.75	1.0	1.25	1.5	2.0	2.5
0.37	1.0	1.25	1.5	2.0	2.5	3.0
0.55	1.0	1.5	2.0	2.5	3.0	4.0
0.75	1.25	2.0	2.5	4.0	5.0	6.0
1.1	1.5	2.5	4.0	5.0	6.0	8.0
1.5	2.5	4.0	5.0	6.0	8.0	/

To choose the required cutting area of cable according to the power of pump and length of external cable to ensure the normal operation of motor.

3.8 Please operate as below instructions for adding cable lines:

3.8.1 Strip a 50-60mm cable with a wire stripper, then strip the rubber hose to reveal a 20-30mm copper wire.

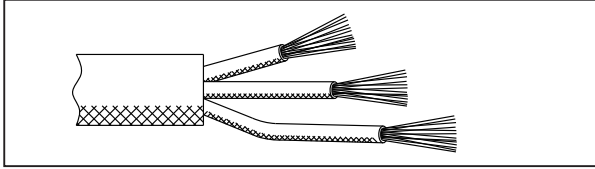

3.8.2 Tighten two cable lines with the same color into spiral shape so as to guarantee close connection;

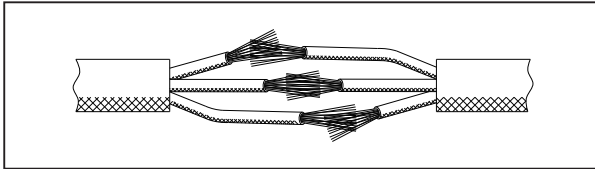

3.8.3 Tightly wind and cover the cable with the electrical insulating tape from the 15-20mm core cord.

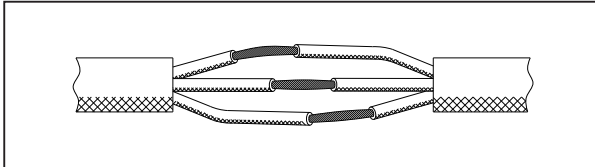

3.8.4 Wrap the cable that is covered with the electrical insulating tape with a waterproof adhesive tape from the 20-30mm core cord. The waterproof adhesive tape should be 10mm longer than the electrical insulating tape at both ends. Before the wrapping, the waterproof tape should be stretched out 1-fold its length and follow the normal use.

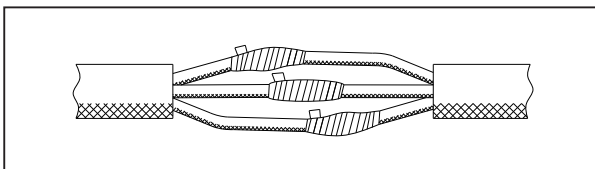

3.8.5 Wrap the cable that is wrapped with the waterproof adhesive tape with the electrical insulating tape.

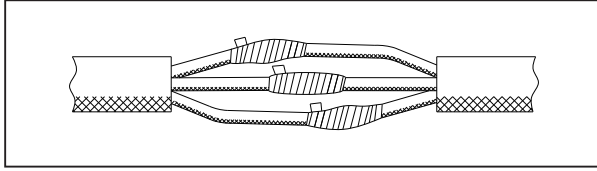

3.8.6 Wrap the cable that is wrapped with the electrical insulating tape with the waterproof adhesive tape. The waterproof adhesive tape should be 10mm longer than the electrical insulating tape at both ends. Before the wrapping, the water proof tape should be stretched out 1-fold its length and follow the normal use.

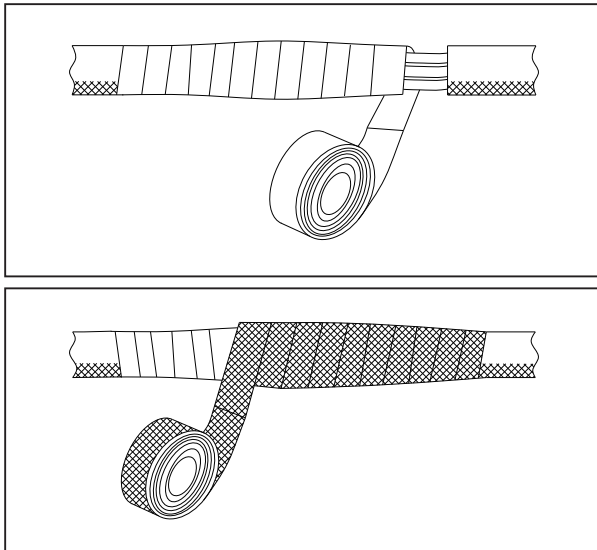

3.8.7 Immerge the junction of the cable into water for 12 hours. Test the insulation resistance of the cable with a 500V megohmmeter. The cold insulation resistance should be no less than 50 MΩ

3.9 The delivery pipe shall be matched to the water outlet (the specification shall be selected based on the performance parameter table). For example, the iron wire or clamp can be used to connect with soft delivery pipes; the screwed joint can be used for steel delivery pipes for further reliable connection. Further, the threading ropes are used at the handle in case that the rope floats in the water. The tied ropes of hoisting electric pump must be firm and durable. The cable lines shall not be stretched but in a natural loose state.

- 3.10 The cables are not allowed for impact and crushing or used as lifting ropes. Further, do not pull the cables randomly at operation so as to avoid electric shock caused by cable damage.
- 3.11 The depth of electric pump in the water shall not be over 80m but 3m above the bottom. Further, the electric pump shall not be sunk into soils. Meanwhile, the user shall prevent sundries to block nets or impellers, because it will lead to abnormal works. Please check the water level during works to avoid exposed or dry works, or else it will burn the electrical machine and other parts.
- 3.12 During usage, washing, swimming or animals are not allowed within working regions. The safety warning label “ electric shock risk, no entry ” shall be set up on the site to prevent accidents.
- 3.13 The oil-filled electrical machine has been filled with appropriate food machine oil at the time of ex-factory. The users are not allowed to fill in any water or oil into the electrical machine (except for maintenance).
- 3.14 The oil-filled electrical machine is filled with food machine oil that may be leaked when it is damaged or break down. Under the use applications such as planting, cultivation or the transportation and processing of drinking water and food, etc, the leaked food machine oil may cause certain damage to plants and cultured animals or pollute drinking water or food. The user shall evaluate the use environment as well as related consequence before selecting this product so as to confirm its proper use. If necessary, please invite some related professional personnel. If there has food machine oil leakage, please stop using and deal with it properly.
- 3.15 The power source shall be cut off at the time of adjusting position or contacting with electric pumps in case of any accidents. The electric pump shall not be lifted away from water surface before shunting down power source so as to guarantee safety.
- 3.16 The electric pump belongs to specialized technology-based product. The unqualified repairman shall not conduct any randomly disassemble. The sealing and insulation testing must be conducted after laid-up and reassembly.
- 3.17 The maintenance shall be conducted on electric pumps after 3,000 hours normal operation. The maintenance shall be conducted on electric pumps after 3,000 hours normal operation. Various easily damaged parts such as mechanical seal, bearing, impeller, and so on must be replaced. The air pressure test must be conducted on motor and oil chambers after laid-up or changing mechanical seal. The test pressure is 0.4 Mpa. There shall be no leakage within five minutes.
- 3.18 The pump shall not be sunk into water for long-term nonuse. Instead, the pump shall be put in the clear water for several minutes of operation so as to clean mud and other dirties inside and outside of the pump. Further, the anti-rust oil shall be coated on the pump, then it shall be put in a dry and ventilated place. The electric pump with rather long-term use shall be repainted or treated by anti-rust oil according to its surface corrosion status.

WIRING DIAGRAM

Single phase with capacitor connection demonstration

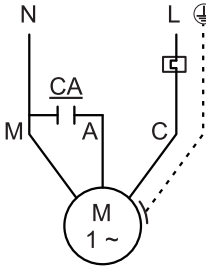

Single phase with built-in capacitor connection demonstration

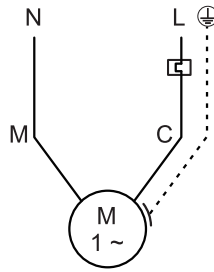

TECHNICAL DATA

Model	Voltage	Output Power	Max.flow	Max.head	Power cord length	Max.liquid temperature
3SDM2/21	230V ~ 50Hz	0.55kW	50L/min	89m	20m	+35°C
3SDM4/16	230V ~ 50Hz	0.75kW	100L/min	66m	20m	+35°C
3.5SDM4/11	230V ~ 50Hz	0.75kW	105L/min	62m	20m	+35°C
4SDM4/6	230V ~ 50Hz	0.37kW	110L/min	44m	20m	+35°C
4SDM8/9	230V ~ 50Hz	1.1kW	190L/min	57m	20m	+35°C

Model	Voltage	Output Power	Max.flow	Max.head	Power cord length	Max.liquid temperature
4SSM4/5	115V ~ 60Hz	0.5HP (0.37kW)	105L/min	51m	10m	+35°C
	230V ~ 60Hz					
4SSM5/6	115V ~ 60Hz	1HP (0.75kW)	140L/min	63m	10m	+35°C
	230V ~ 60Hz					
4SSM5/8	115V ~ 60Hz	1.5HP (1.1kW)	140L/min	84m	10m	+35°C
	230V ~ 60Hz					
4SSM5/12	230V ~ 60Hz	2HP(1.5kW)	140L/min	130m	10m	+35°C
4SSM5/18	230V ~ 60Hz	3HP(2.2kW)	140L/min	195m	10m	+35°C

FAILURE REASONS AND TROUBLESHOOTING METHOD

Fault phenomenon	Reasons	Solutions
Motor: out of operation	<ol style="list-style-type: none"> 1. Too much low voltage leads to failed start-up; 2. Stuck impeller or stator and rotor; 3. The welding lines of capacitor and protector fall off or to be burnt; 4. Burnt stator winding or open circuit. 	<ol style="list-style-type: none"> 1. Use a voltage regulator for further adjustment; 2. Check causes and then take the corresponding measures; 3. Take off the water inlet valve to clean stoppers of impellers as well as silt of sand-proof cover; 4. Re-weld falling wires or change damaged parts; 5. Send to maintenance unit to replace or repair windings.
No water or no enough water amount	<ol style="list-style-type: none"> 1. Too much low voltage leads to no enough rotation or reduced water amount; 2. Too high lift that has exceeded electric pump's lift capacity; 3. Serious wear of impellers; 4. Open circuit of stator winding. 	<ol style="list-style-type: none"> 1. Adjust voltage; 2. Decrease lift or buy another electric pump according to practical situation; 3. Clean blocked sundries; 4. Change impeller or send it to maintenance unit; 5. Send it to maintenance unit for further repair.
Frequently worked protectors	<ol style="list-style-type: none"> 1. Too much low voltage leads to increased current and serious motor heating; 2. Too much low lift leads to increased water drainage and serious motor overload; 3. Abnormal wear of rotors or parts; 4. The electric pump is exposed above water or operated in a dry environment; 5. Damaged sealing; water inflow of machine winding; 6. Serious bearing wear (loudly noise) and increased friction force. 	<ol style="list-style-type: none"> 1. Adjust voltage; 2. Use iron wire to narrow water outlet so as to reduce outflow; 3. Adjust or replace parts; 4. Reduce installation height; 5. Replace sealing element and dry the electric machine; 6. Replace bearing.



Disposal: This product is subject to the provision of European Directive 2012/19/EC. The symbol showing a wheeled bin crossed through indicates that the product requires separate refuse collection in the European Union. This applies to the product and all accessories marked with this symbol. Products marked as such may not be discarded with normal domestic waste, but must be taken to a collection point for recycling electrical and electronic devices.

Importer: WAITCHX

Address: 250 bis boulevard Saint-Germain 75007 Paris.



Importer: FREE MOOD LTD

Address: 2 Holywell Lane, London, England, EC2A 3ET



E-mail: CustomerService@vevor.com

Manufacturer: Zhejiang Doyin Technology Co., Ltd.

Add: No.19, South of Songhang Road, Eastern New District, Wenling City, Taizhou, Zhejiang, China.

Made in China

VEVOR[®]

E-mail: CustomerService@vevor.com