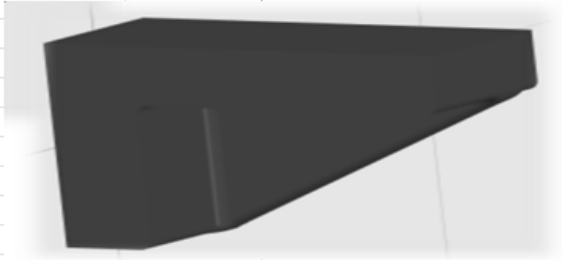
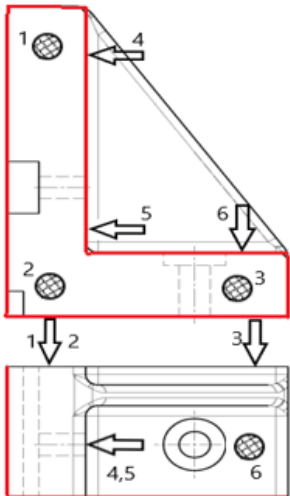
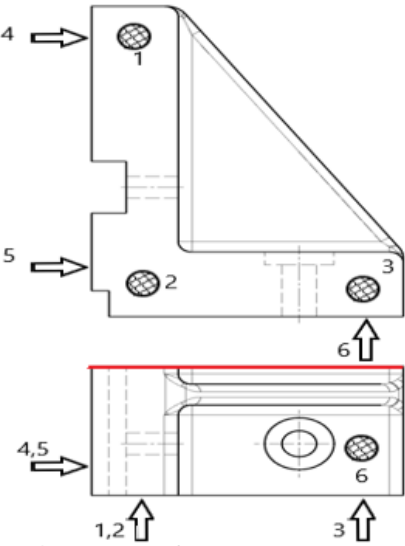
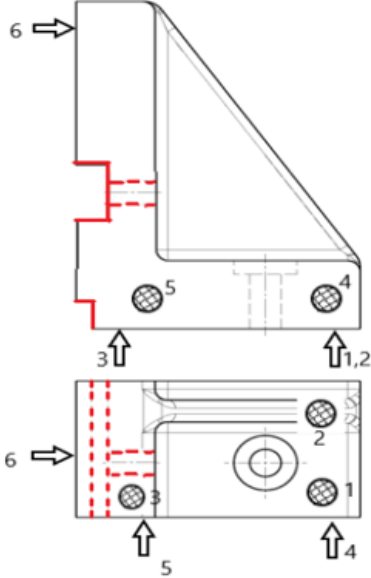
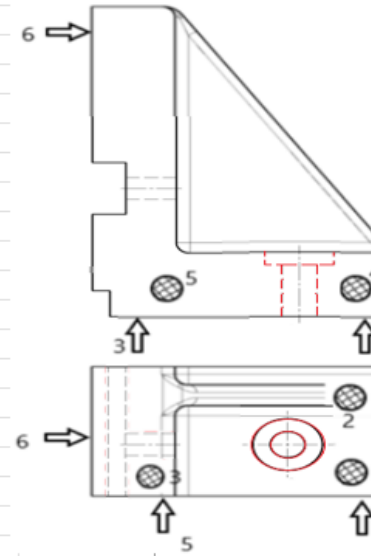

# GAMME OPERATIONNELLE

Ensemble			Etudiants SEMMOUDI-MARTIN
Elément Equerre			
Nb	Matière	Débit	Groupe SEMMOUDI-MARTIN
N° Phase	Description phases et opérations	Machine et outillage	Croquis de la pièce et usinage
10	Obtention du brut	Moulage Sable	
20	Fraisage	Fraiseuse 3 axes	
	Réaliser F1-F4-F7	Fraise 2 tailles	
30	Fraisage	Fraiseuse 3 axes	
	Réaliser F7	Fraise 2 tailles	

40	Fraisage, Percage, Taraudage	Fraiseuse 3 axes	
	Réaliser F8,F9,F10 Réaliser F3,F5 Réaliser D3, A1	Fraise 2 tailles Foret 8,4 mm Taraud M10	
50	Percage, Lamage	Fraiseuse 3 axes	
	Réaliser D1, D2	Foret 10 Foret 20	
60	Contrôle	MMT	