

# Using the TL431 for Undervoltage and Overvoltage Detection

Ricardo Rivera-Matos, Ethan Than, Marcoo Zamora

## ABSTRACT

TL431 is a shunt voltage reference that is versatile in its form and function. The TL431 is part of the "431" family of products which consists of other 431 products such as the TL431LI, ATL431LI, and TLV431. The 431 family architecture consists of a voltage reference and internal error amplifier that allow for many configurations and applications circuits. The 432 family of products are just an alternate pin out of the 431 family with similar performance and functionality. Any circuit in this application note will apply to the 431 family of products. Circuits for these applications are shown and guidance is provided for choosing the component values around the voltage reference with key parameter value graphs for the TL431 and ATL431LI. This document will also cover common design problems and solutions when using TL431 in open-loop configuration for voltage detection and other applications.

## Contents

1	Introduction .....	1
2	Voltage Comparator Application .....	2
3	Design Considerations for $V_{sup}$ and $R_{sup}$ .....	4
4	Design Considerations for $V_{in}$ and $R_{in}$ .....	7
5	ATL431LI Benefits in Open-Loop Applications .....	9
6	Window Voltage Detector Application .....	10
7	Alternative Device Recommendations .....	11

## Trademarks

All trademarks are the property of their respective owners.

## 1 Introduction

431 products such as the TL431 and ATL431LI are adjustable shunt voltage references that are used to take an input voltage and produce a regulated output voltage determined by the device characteristics. The TL431 has two main modes of operation, closed-loop configuration or open-loop configuration. Users can connect the REF pin to the CATHODE pin in a closed-loop configuration to close the feedback loop and regulate the output of the 431 device. Furthermore, engineers can also use a resistor gain network to increase the regulated output voltage in this configuration. For more information on closed-loop configuration can be found in [SLVA445](#).

Engineers can break the closed loop feedback from REF to CATHODE pins to use an TL431 in open-loop configuration which increases the versatility of the device. The TL431 in open-loop configuration is often used in as a voltage comparator, undervoltage monitor, overvoltage monitor, window voltage detector and many other type of uses. The [TL431](#) is a shunt voltage reference commonly used for these applications.

## 2 Voltage Comparator Application

Figure 1 shows the TL431 functional block diagram in an open-loop configuration application. The input voltage is sent into the REF pin and is compared to the internal reference voltage ( $V_{ref}$ ). If the input voltage on the REF pin is less than the reference voltage, then the transistor in the block diagram remains off and acts as an open circuit that exists between the cathode and the anode. In this state,  $V_{sup}$  and  $V_{out}$  (also known as  $V_{KA}$  in this schematic) are equal and a logic "high" output is produced. Conversely, if the input voltage on the REF pin is greater than the reference voltage ( $V_{ref}$ ), then the transistor in the block diagram conducts and current flows between the cathode and the anode. In this state, the  $V_{KA(low)}$  and  $V_{out}$  are equal and a logic "low" output is produced as shown in Equation 1. Design considerations will be discussed in more detail in Section 5.

$$V_{out} = \begin{cases} V_{sup}^*, & V_{IN} < V_{ref} \\ V_{KA(low)}^{**}, & V_{IN} > V_{ref} \end{cases}$$

\*  $V_{sup}$  should be less than the  $V_{KA}$  ABS MAX.

\*\*  $V_{KA(low)}$  value can vary per device, see Section 3 for more details.

(1)

**CAUTION**

This is the most common question for TL431: What is the max voltage on the TL431 REF pin? Answer: There is no max voltage on REF pin because it depends on the ABS max  $I_{ref}$  current. See for design considerations and examples for  $I_{ref}$ .

Figure 2 shows an example output of the voltage comparator in red with the input waveform in shown in blue.

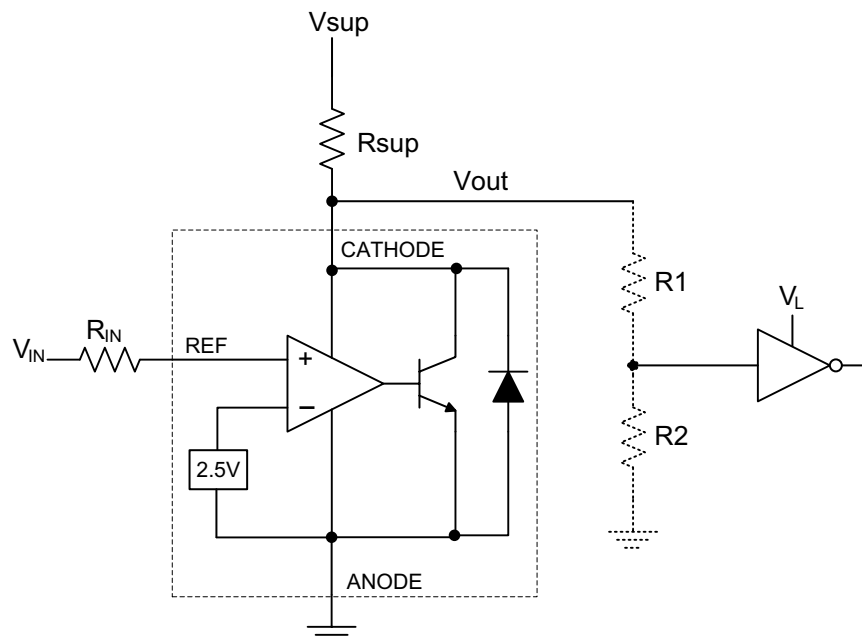

Figure 1. Example 431 Open-Loop Configuration Application Functional Block Diagram With Optional Op-Amp

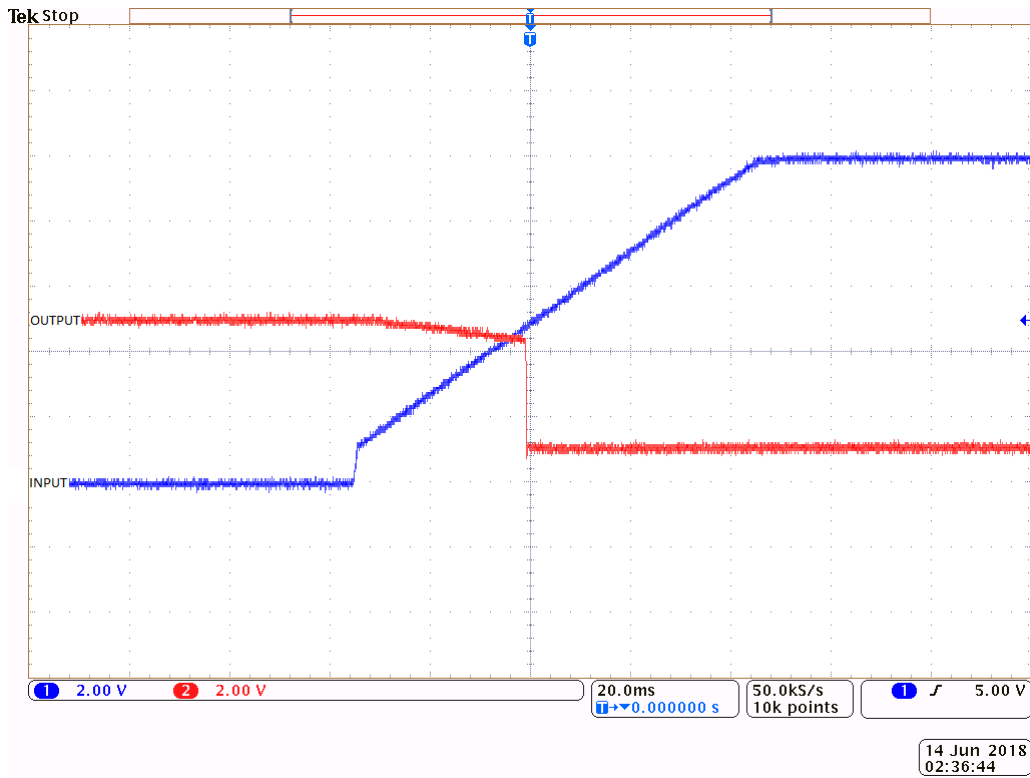

Figure 2. Voltage Comparator Output

### 3 Design Considerations for $V_{sup}$ and $R_{sup}$

Four main parameters must be considered to design open-loop configurations such as overvoltage detectors as shown in Figure 3. The  $V_{sup}$  and  $R_{sup}$  must be designed to provide at least the minimum cathode current ( $I_{KA}$ ), but they must not exceed the maximum cathode voltage or current value as shown in the device ABS MAX tables. The value set to  $V_{sup}$  will be the output value for the “high” state.  $V_{sup}$  must be limited to the recommended operating conditions table max  $V_{KA}$ . The  $V_{ref}$  voltage value should be as low as possible to provide ample to the “high” state.

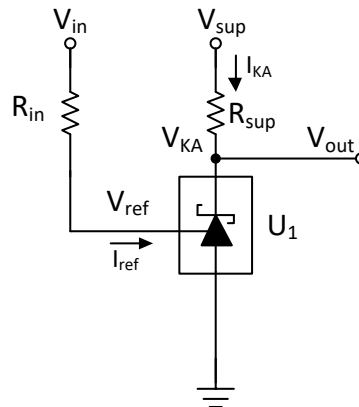

Figure 3. Basic comparator using TL431 or ATL431LI

The “low” state will be set by the characteristic value of  $V_{ref}$  and its dependencies such as  $I_{KA}$ ,  $I_{ref}$ , and temperature. The variations on  $V_{KA}$  is shown in Figure 4 for TL431 and Figure 5 for ATL431LI. It is possible to see how different devices react to changing conditions and how the ATL431LI is more stable across temperature and current.

### TL431 $V_{KA}$ Open Loop "Low"

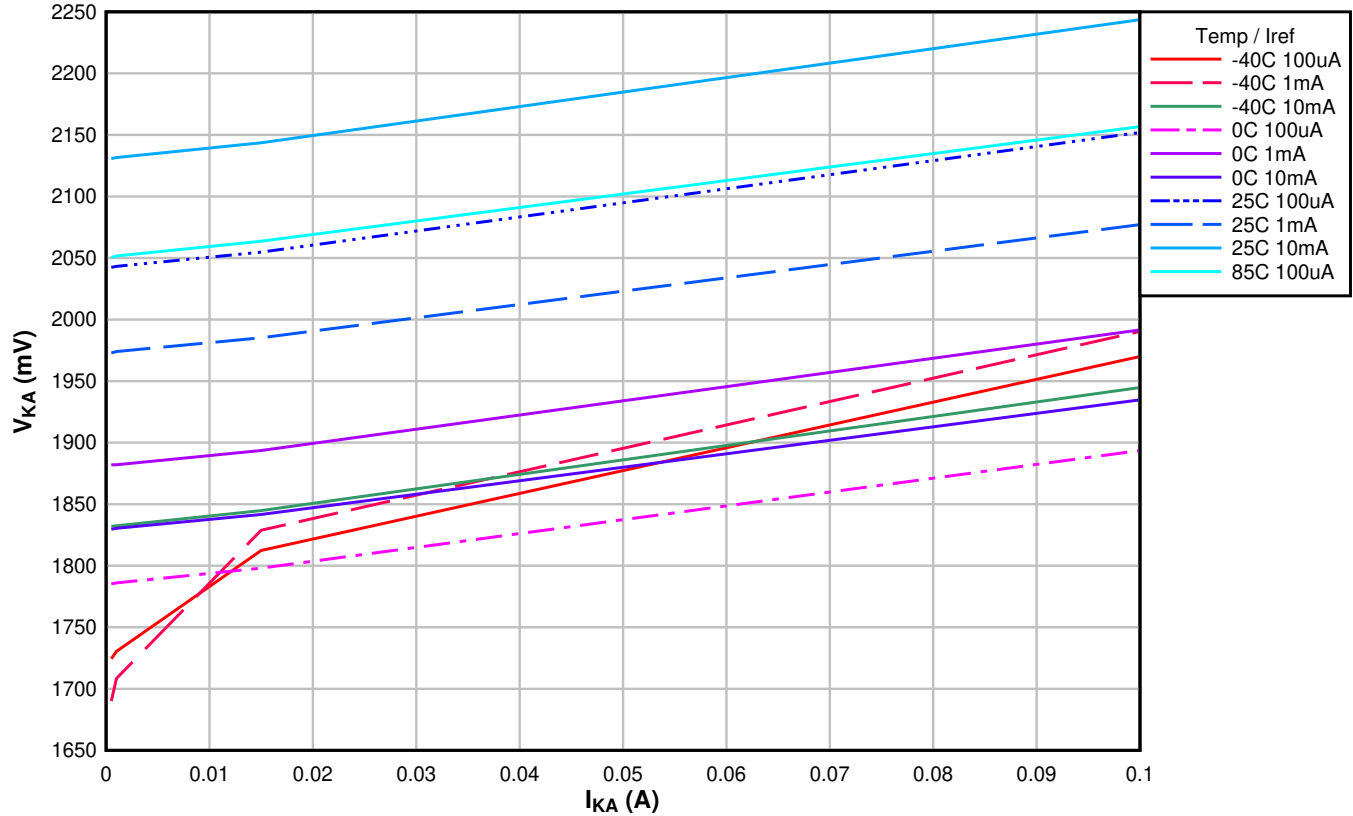

Figure 4. TL431  $V_{KA}$  (low)

### ATL431LI $V_{KA}$ Open Loop "Low"

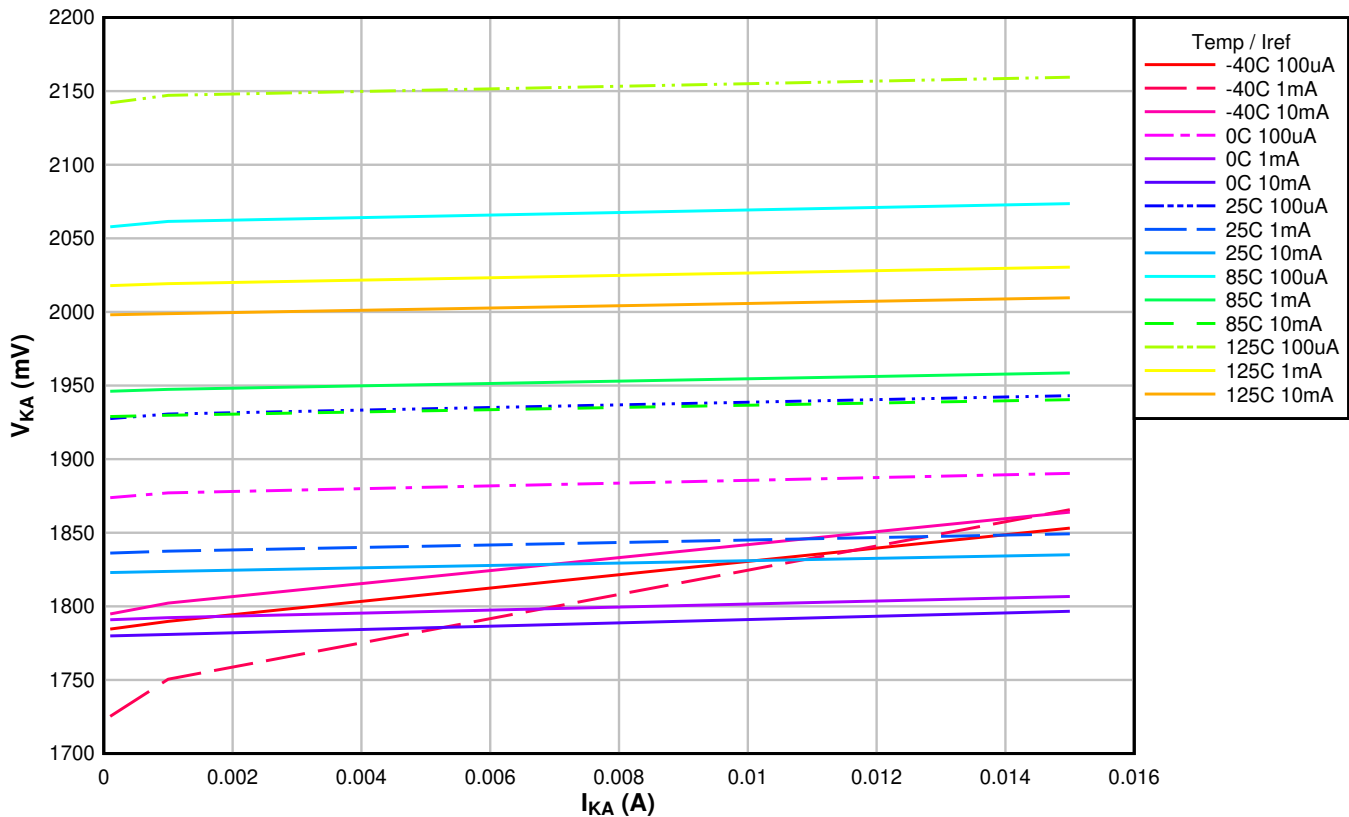

Figure 5. ATL431LI  $V_{KA}$  (low)

Table 1. Typical  $V_{ref}$  and  $V_{KA(low)}$

Devices	Bandgap Reference Voltage	$V_{KA}$ (low)
TL431, TL431LI, TL431LI, ATL431, ATL431LI	2.495V, 2.5V	~2V
TLV431, TLVH431	1.24V	~1V

The  $V_{ka}$  in its "low" stage ( $V_{KA(low)}$ ) is limited to ~2V for TL431 and ATL431LI or 1V for TLV431 as shown in Table 1.

Figure 1 shows how a voltage divider network and logical inverter/buffer can also be used to further manipulate the output levels and behavior as necessary. This is useful when the output needs to be level shifted for a digital GPIO with a low  $V_{IL}$ . A simpler design is shown in Figure 6 as it employs a BJT to invert the logic and drive the output to  $V_{sup}$  or GND.

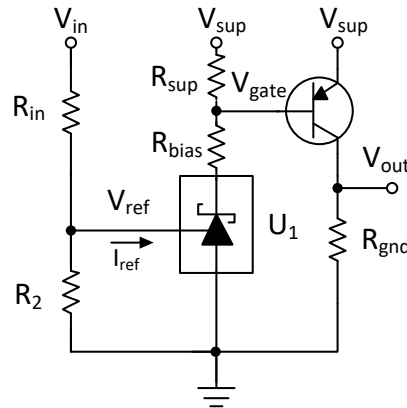

Figure 6. Comparator With Adjustable Threshold And Near Rail To Rail Output

$R_{sup}$  must be chosen to minimize  $I_{KA}$  into the device to have a correct  $V_{ka}$  value.  $R_{sup}$  is limited by  $I_{KA}$  as shown in Equation 2 where  $I_{KA}$  must be larger than  $I_{KA(min)}$ .

$$I_{KA} = \frac{V_{sup(min)} - V_{KA(low)}}{R_{sup}} - I_{load} \quad (2)$$

#### 4 Design Considerations for $V_{in}$ and $R_{in}$

For the circuit in Figure 7,  $V_{in}$  is the main voltage being monitored by the TL431. The output  $V_{KA}$  does not switch sharply as the voltage at the  $V_{ref}$  pin crosses the  $V_{ref}$  threshold. The increase in  $I_{KA}$  and the consequent roll off in the  $V_{KA}$  begins at voltages as much as 1V below the threshold, as can be seen in Figure 8.

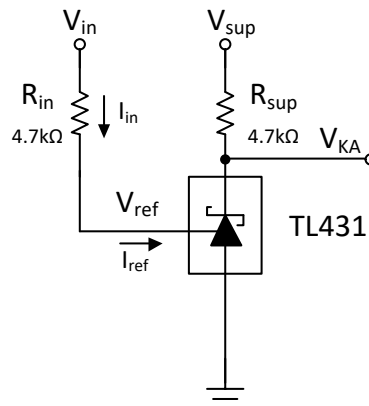
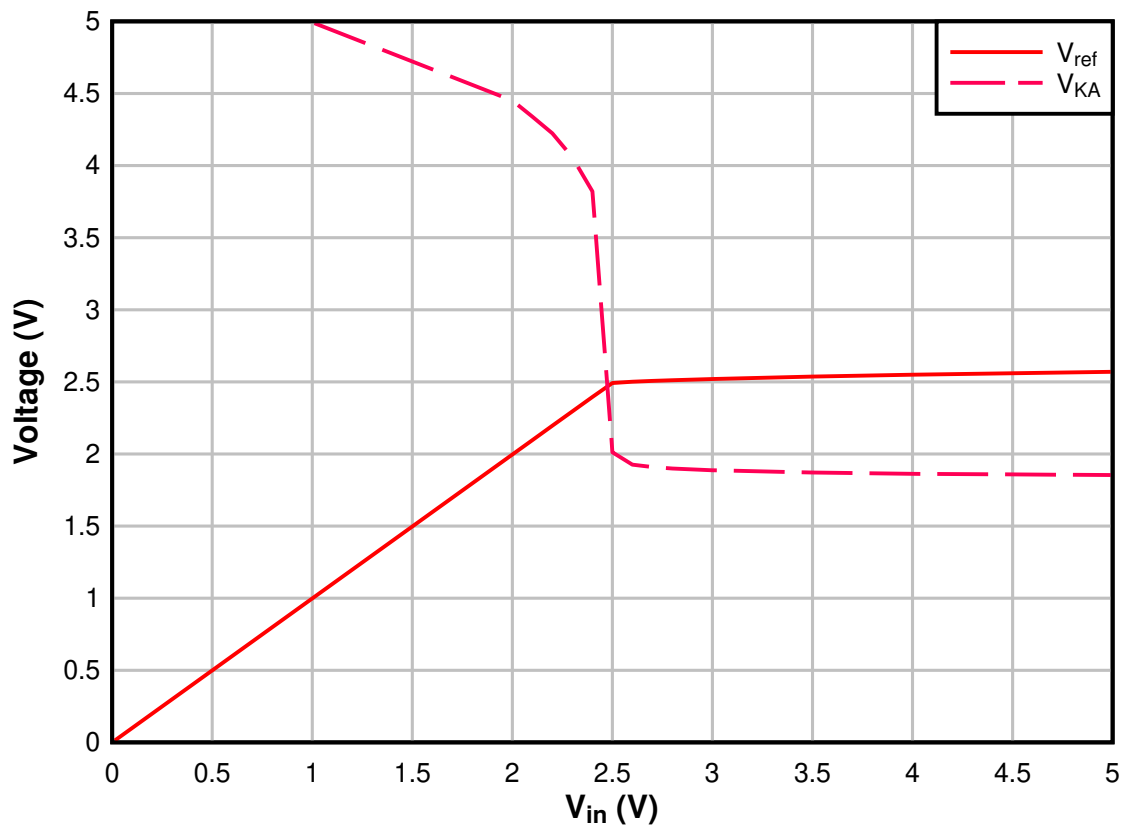

Figure 7. TL431 2.495V Comparator Example

**Figure 8.  $V_{in}$  vs  $V_{KA}$** 

The value for  $R_{IN}$  is critical in the design because must satisfy all the  $I_{ref}$  conditions.  $I_{ref}$  is a value that is limited by  $I_{ref(max)}$  and for the TL431 it is 10mA. Figure 9 shows how  $I_{ref}$  increases until  $V_{ref}$  where it's current is the typical  $I_{ref}$  from the EC table in the TL431 datasheet. After  $V_{ref}$ , the  $I_{ref}$  will grow relative to the value on  $V_{ref}$  and  $V_{in}$  as shown in Equation 3. Figure 9 also shows how  $V_{ref}$  will increase as  $I_{ref}$  increases.

$$I_{ref} = \begin{cases} I_{ref} < I_{ref(typ)}, V_{IN} < V_{ref} \\ I_{ref} \approx \frac{V_{IN} - V_{ref}}{R_{in}} *, V_{IN} > V_{ref} \end{cases}$$

\*  $I_{ref}$  should be kept below  $I_{ref}$  ABS MAX. Check device datasheets for  $I_{ref}$  ABS MAX value. (3)



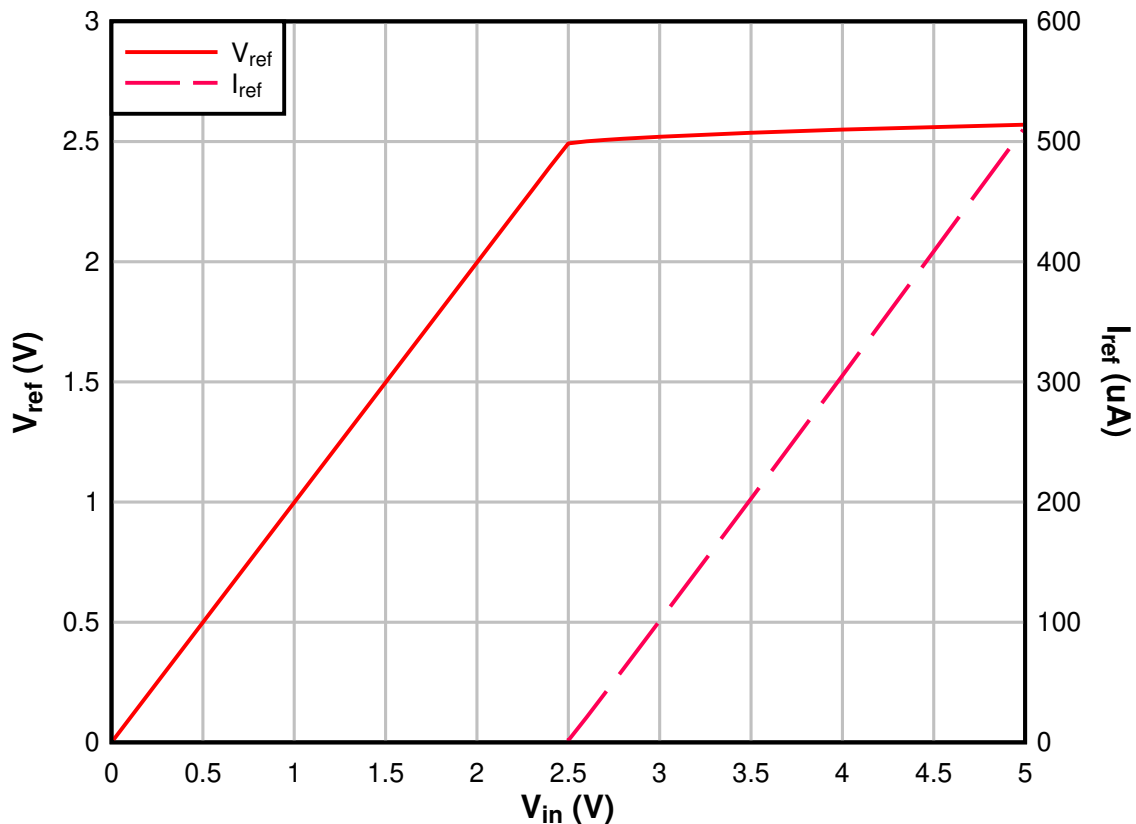

Figure 9.  $V_{in}$  vs  $V_{ref}$  and  $I_{ref}$

Figure 6 voltage divider with  $R_{in}$  and  $R_2$  can be in applications where the threshold  $V_{ref} = 2.495V$  is not sufficient and it needs to be increased.

### 5 ATL431LI Benefits in Open-Loop Applications

The ATL431LI in X2SON package is a small 1mm x 1mm package TL431 like device. Being able to create discrete comparators such as Figure 3 with the ATL431LI allows for a complete solution size of 5mm x 3.5mm with further room for optimization as shown in Figure 10. The ATL431LI has a lower  $I_{KA(min)}$  than the TL431 which allows it to function in low Iq applications such as overvoltage battery protection.

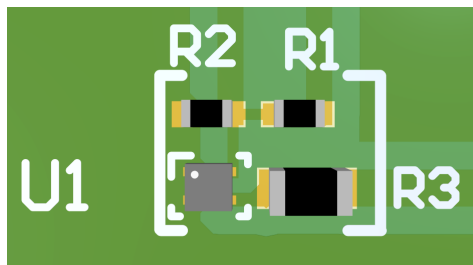

Figure 10. ATL431LI in X2SON Comparator Solution Size

## 6 Window Voltage Detector Application

Figure 11 shows how two 431 shunt voltage references can be applied as a window voltage detector also known as a window comparator. A window voltage detector is circuit that implements both undervoltage and overvoltage detection and alerts the user if the monitored voltage is outside the desired boundary. In this configuration, both shunt voltage references are configured in the open-loop configuration with a pair of resistor divider networks. The first pair of resistors sets the upper threshold voltage ( $V_H$ ) as shown in Equation 4. The second pair of resistors sets the lower threshold voltage ( $V_L$ ) as shown in Equation 5.

$$V_H = \left(1 + \frac{R_2}{R_1}\right) V_{REF} \quad (4)$$

$$V_L = \left(1 + \frac{R_3}{R_4}\right) V_{REF} \quad (5)$$

The window voltage detector will go “high” until the lower threshold voltage is reached, then go “low” until the upper threshold voltage is reached again. Once the upper threshold voltage is reached, the window comparator output goes “high” again. The logic “high” output voltage is set by  $V_{PULLUP}$ . The logic “low” output voltage is set by  $V_{KA(low)}$ . Figure 12 shows the output of this circuit. The input is shown in blue as a ramp from 0 to 20 volts. The output in red is shown with a high state of 5 volts and a low state approximately equal to 2V. In this example, the lower threshold was set to 5 volts and the upper threshold was set to 13 volts.

$$V_{out} = \begin{cases} V_{PULLUP}, & V_{IN} < V_L \\ V_{ref}, & V_L < V_{IN} < V_H \\ V_{PULLUP}, & V_H < V_{IN} \end{cases} \quad (6)$$

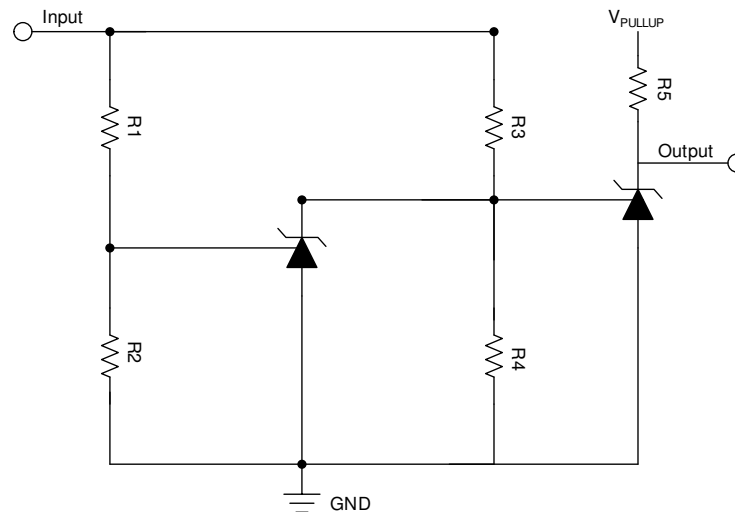

Figure 11. Window Voltage Detector Application Schematic

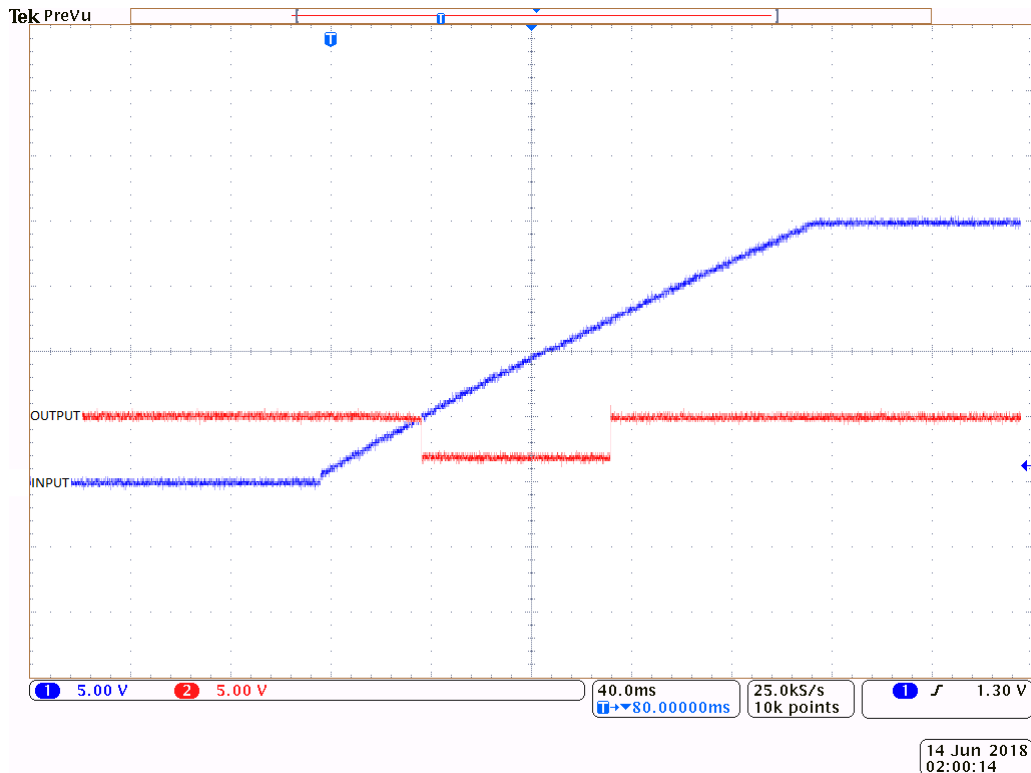

Figure 12. Window Voltage Detector Output

For the window voltage detector application design, the engineer must use Equation 4 and Equation 5 to determine the upper and lower thresholds, respectively. As with the voltage detector configuration, take care when designing this circuit to ensure the maximum current ratings for both the REF and CATHODE pins are not exceeded while ensuring minimum operating conditions.

## 7 Alternative Device Recommendations

There are important performance metrics to consider when choosing a shunt voltage reference for a comparator application. Two important parameters to consider are the bandgap reference voltage and the minimum cathode current. A lower bandgap reference voltage as seen in the TLV431, allows for a lower logic "low" output voltage without the need for external hardware. The lower cathode current of the ATL431 is designed for low power applications. Finally, the TL431 provides an effective, optimized solution, as well.

Table 2. Alternative Device Recommendations

Device	Bandgap Reference	Minimum Cathode Current
TL431	$V_{ref} = 2.495\text{ V}$	$I_{min} = 1\text{ mA}$
TLV431	$V_{ref} = 1.24\text{ V}$	$I_{min} = 80\text{ }\mu\text{A}$
ATL431	$V_{ref} = 2.5\text{ V}$	$I_{min} = 35\text{ }\mu\text{A}$
TL431LI	$V_{ref} = 2.495\text{ V}$	$I_{min} = 1\text{ mA}$
ATL431LI	$V_{ref} = 2.5\text{ V}$	$I_{min} = 80\text{ }\mu\text{A}$

---

## Revision History

NOTE: Page numbers for previous revisions may differ from page numbers in the current version.

<b>Changes from Original (July 2018) to A Revision</b>	<b>Page</b>
• Changed document throughout .....	1

---

## IMPORTANT NOTICE AND DISCLAIMER

TI PROVIDES TECHNICAL AND RELIABILITY DATA (INCLUDING DATASHEETS), DESIGN RESOURCES (INCLUDING REFERENCE DESIGNS), APPLICATION OR OTHER DESIGN ADVICE, WEB TOOLS, SAFETY INFORMATION, AND OTHER RESOURCES "AS IS" AND WITH ALL FAULTS, AND DISCLAIMS ALL WARRANTIES, EXPRESS AND IMPLIED, INCLUDING WITHOUT LIMITATION ANY IMPLIED WARRANTIES OF MERCHANTABILITY, FITNESS FOR A PARTICULAR PURPOSE OR NON-INFRINGEMENT OF THIRD PARTY INTELLECTUAL PROPERTY RIGHTS.

These resources are intended for skilled developers designing with TI products. You are solely responsible for (1) selecting the appropriate TI products for your application, (2) designing, validating and testing your application, and (3) ensuring your application meets applicable standards, and any other safety, security, or other requirements. These resources are subject to change without notice. TI grants you permission to use these resources only for development of an application that uses the TI products described in the resource. Other reproduction and display of these resources is prohibited. No license is granted to any other TI intellectual property right or to any third party intellectual property right. TI disclaims responsibility for, and you will fully indemnify TI and its representatives against, any claims, damages, costs, losses, and liabilities arising out of your use of these resources.

TI's products are provided subject to TI's Terms of Sale ([www.ti.com/legal/termsofsale.html](http://www.ti.com/legal/termsofsale.html)) or other applicable terms available either on [ti.com](http://ti.com) or provided in conjunction with such TI products. TI's provision of these resources does not expand or otherwise alter TI's applicable warranties or warranty disclaimers for TI products.

Mailing Address: Texas Instruments, Post Office Box 655303, Dallas, Texas 75265  
Copyright © 2019, Texas Instruments Incorporated