

# MOBYLETTE

## Série 40

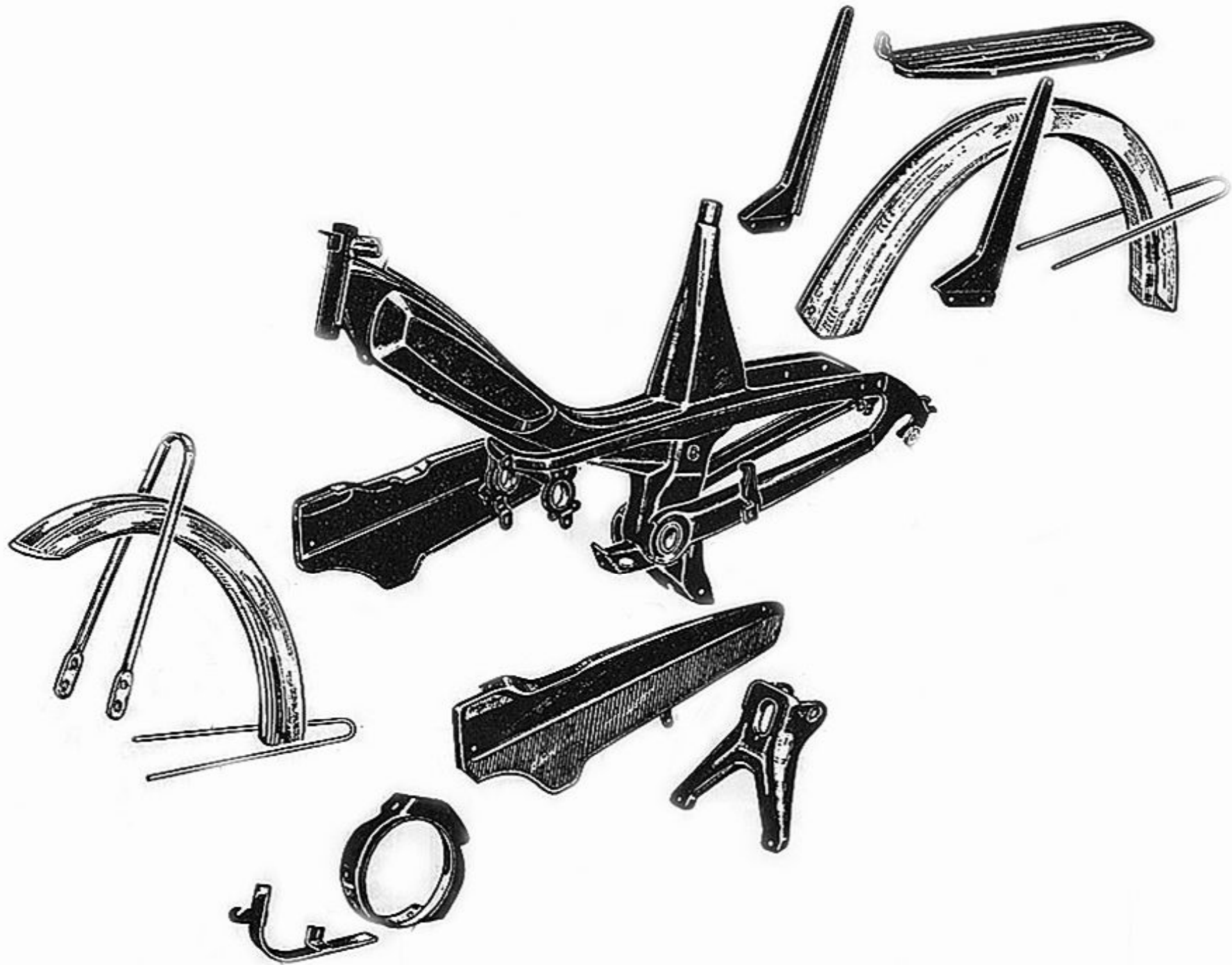

# CADRE - CARTERS - BÉQUILLE

41S

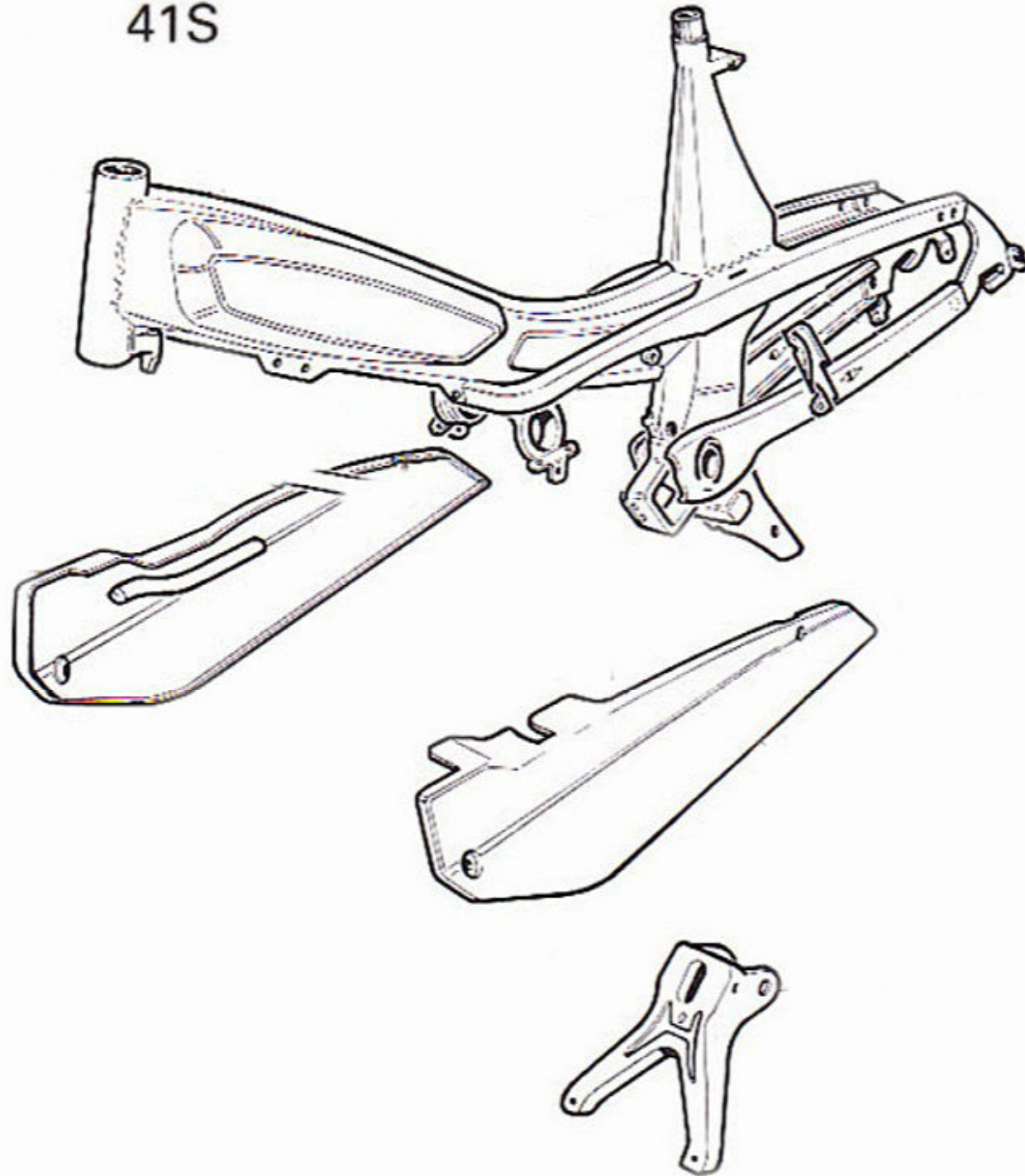

**MOBYLETTE**

**Série 50**

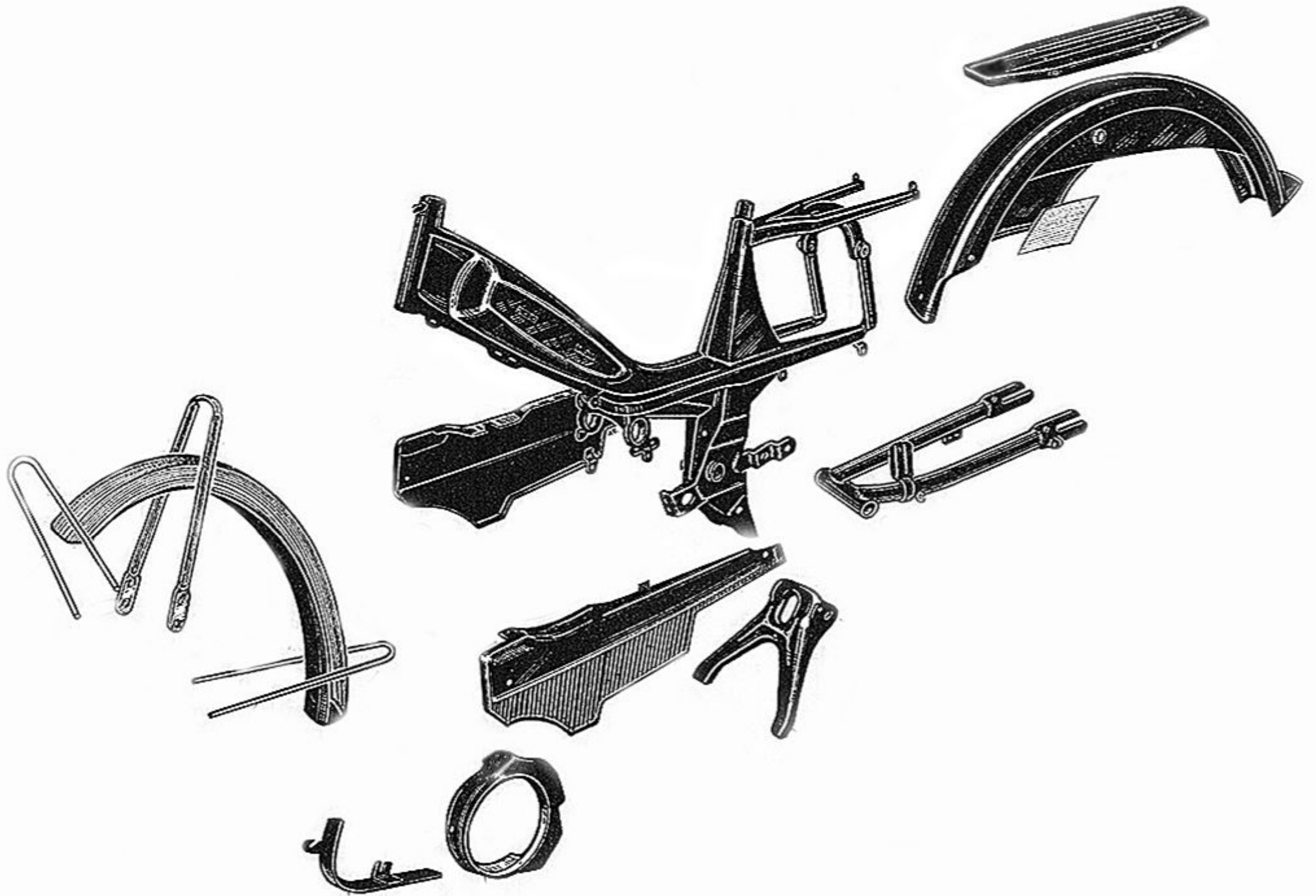

# CADRE - BRAS OSCILLANT - BÉQUILLE

## DAYTONA CRUISER

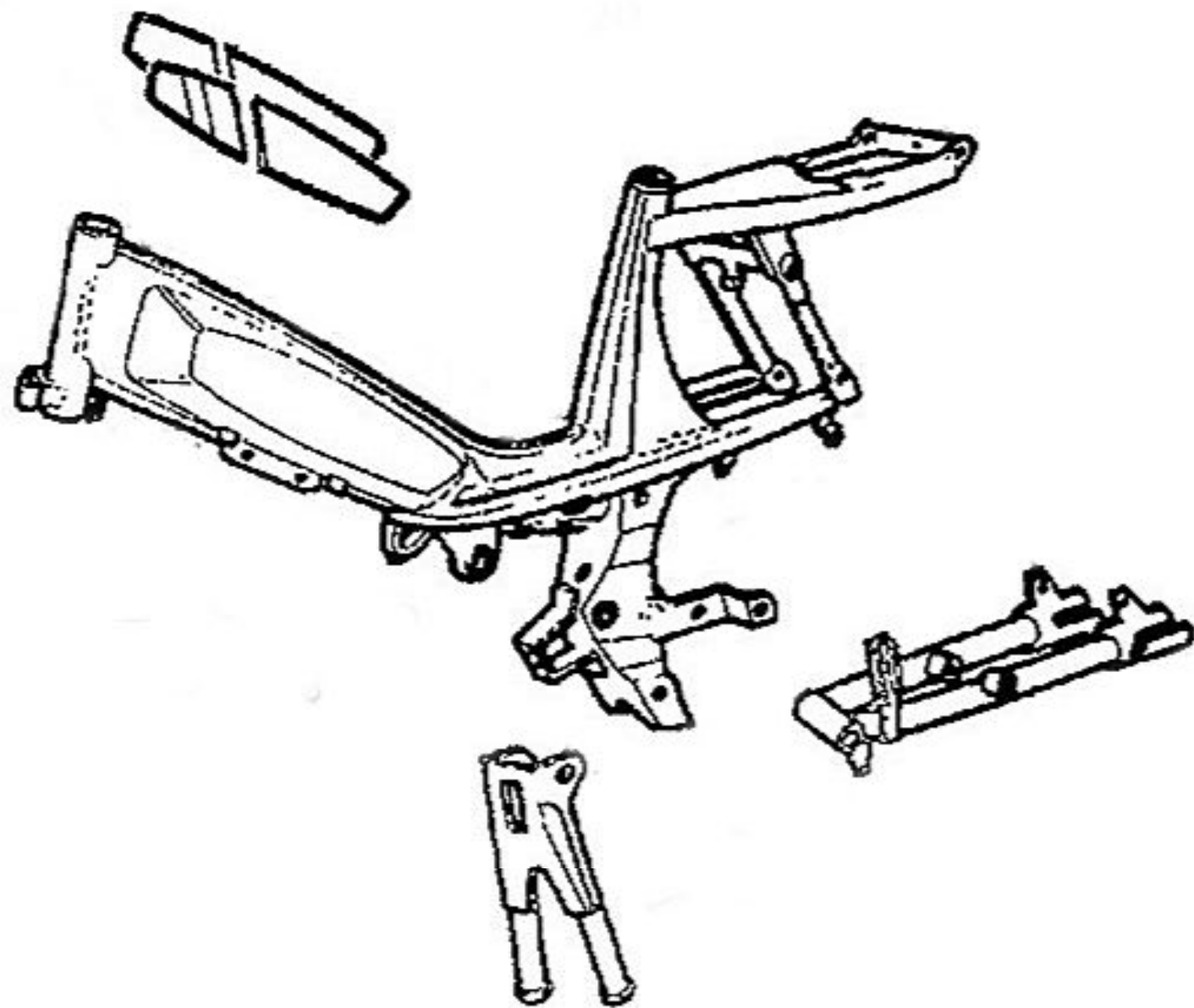

51 SUPER - 51 BLACK - 51 WEST - 51 COPPER BLACK 51 SUPER BLUE  
51 WHITE HORSE - 51 NEW WEST - 51 SU SPÉCIALE

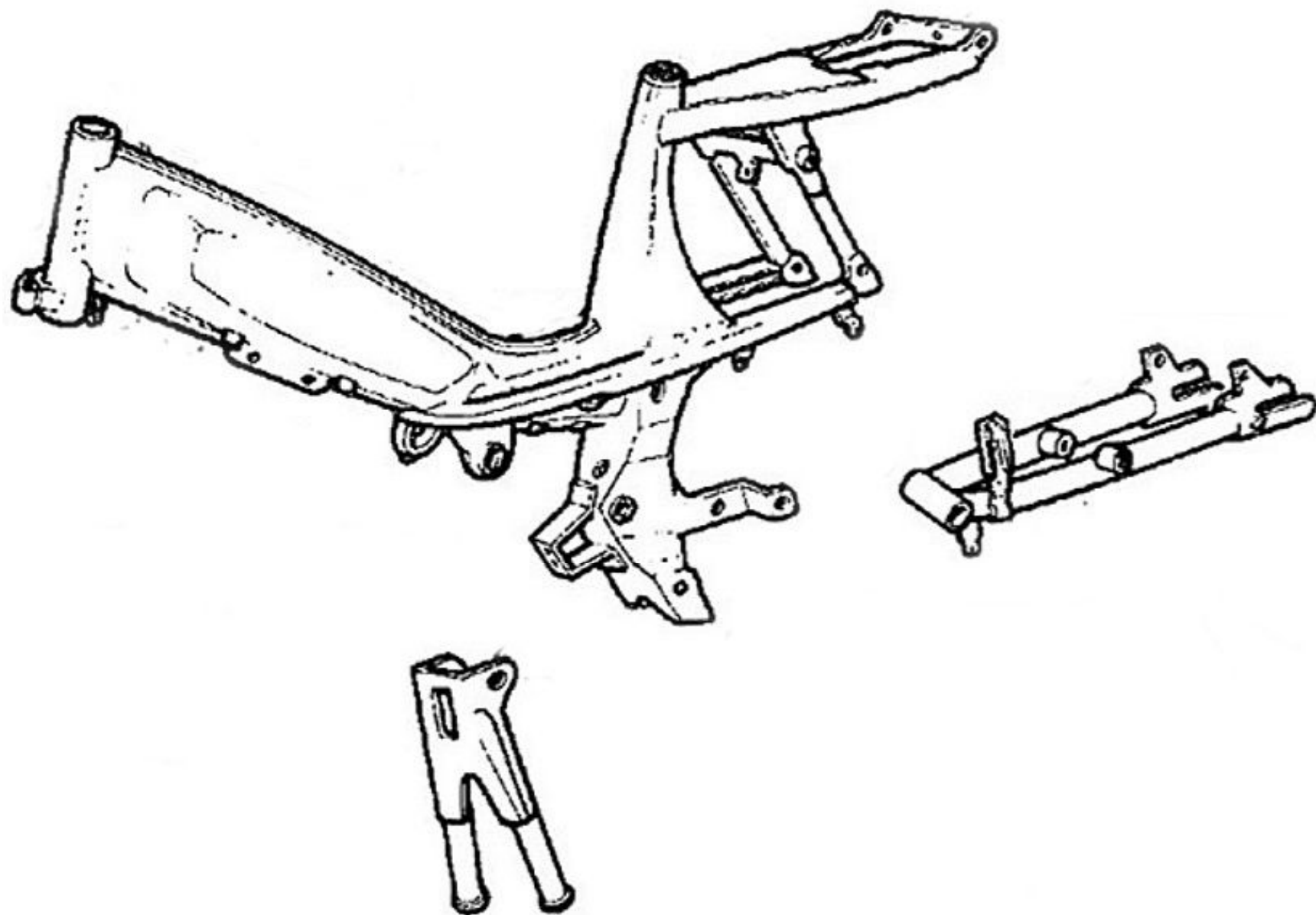

51 SUPER - 51 BLACK - 51 WEST - 51 COPPER BLACK  
51 WHITE HORSE - 51 NEW WEST

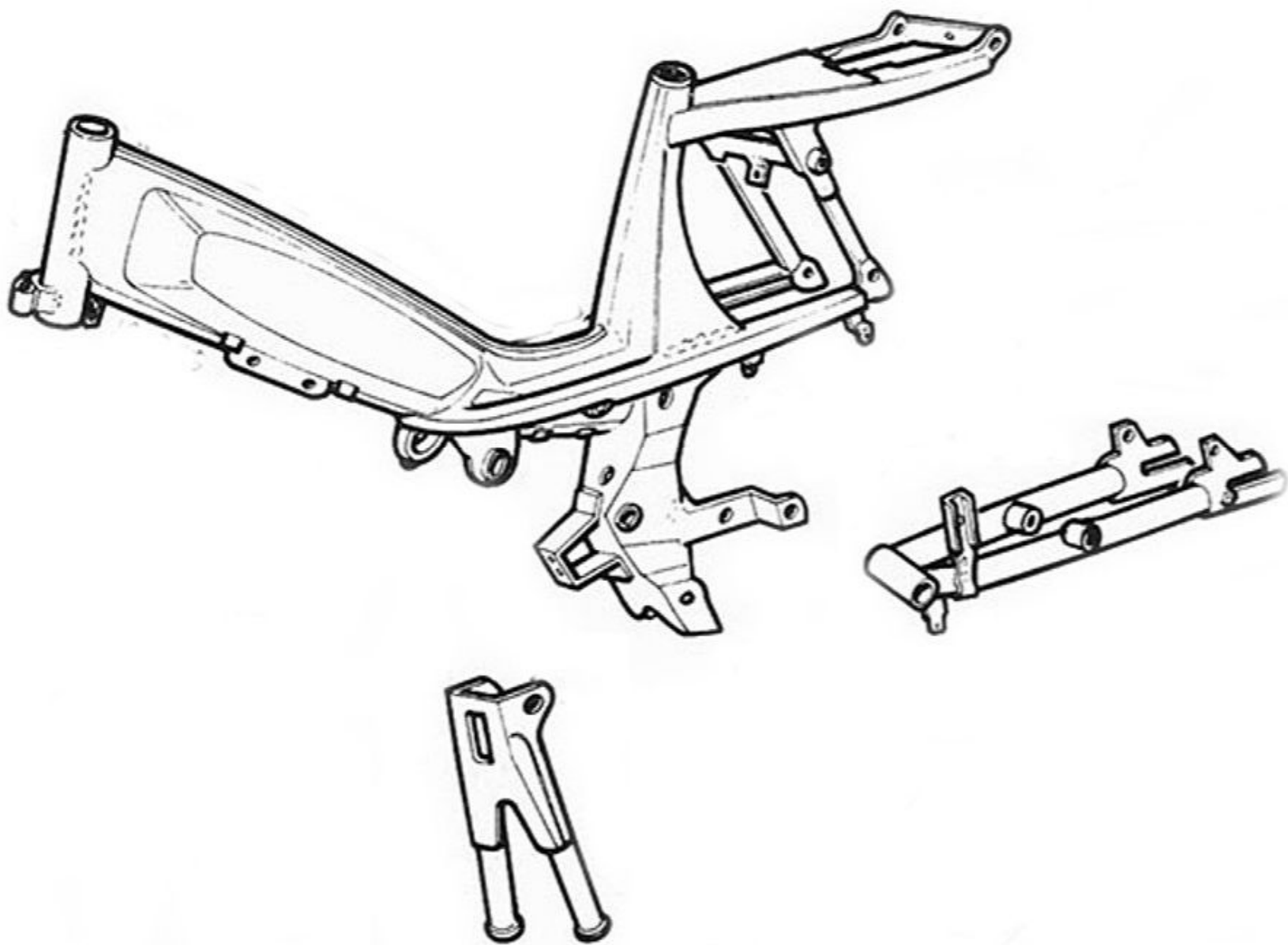

# CADRE - BRAS OSCILLANT - BÉQUILLE

51V - 51VL

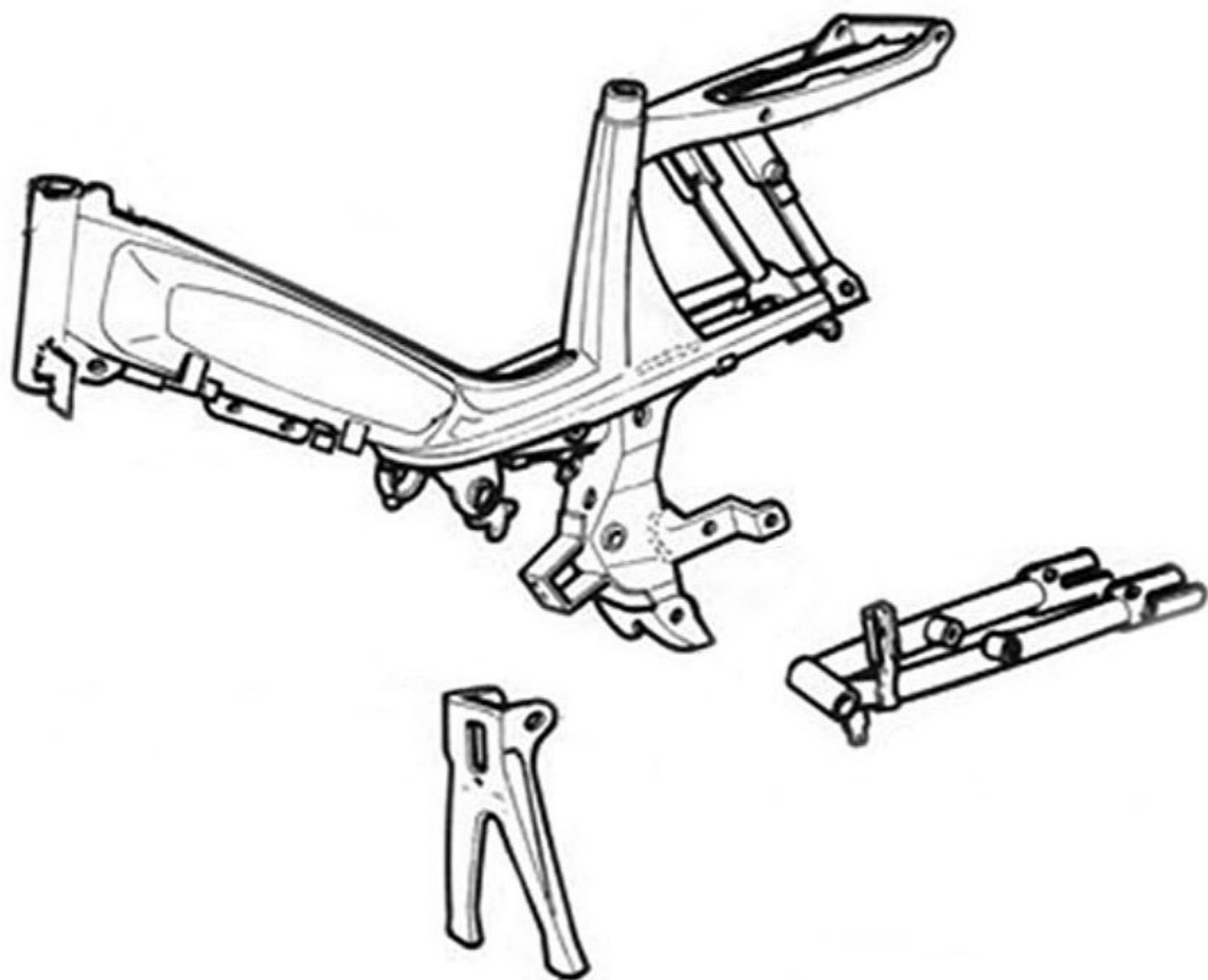

# CADRE - BRAS OSCILLANT - BÉQUILLE

~CF~

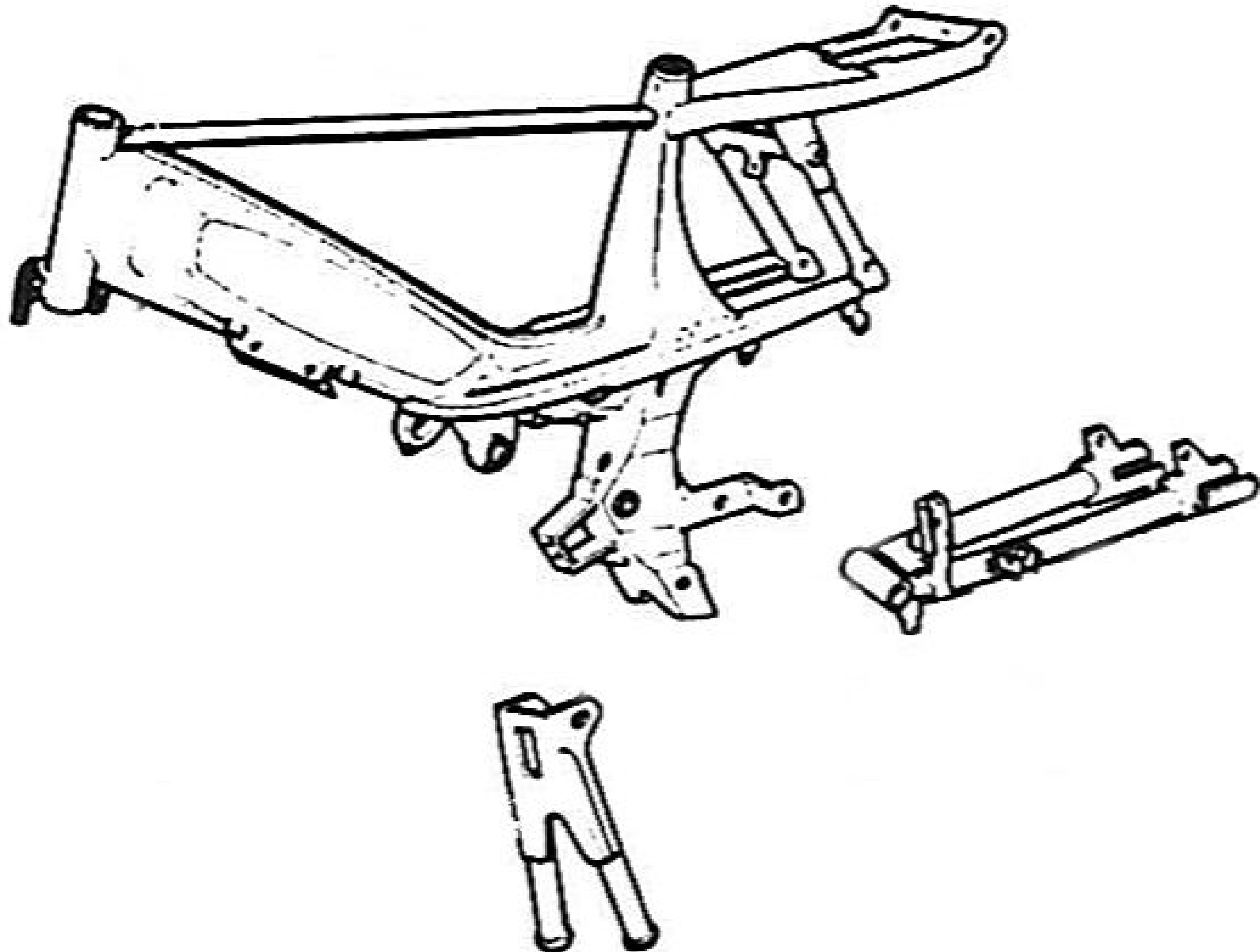



# 51 Magnum 1991

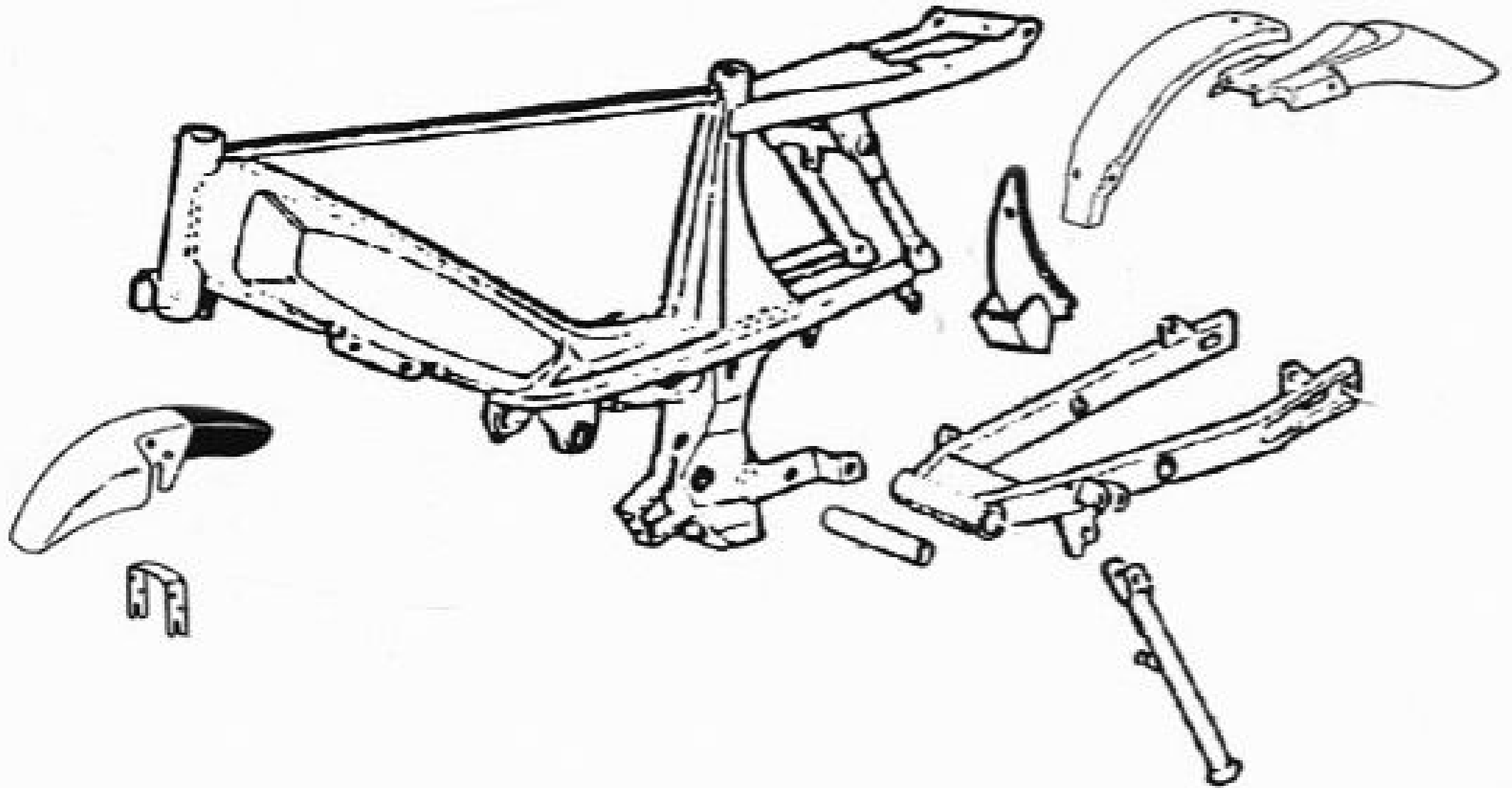

85 N - 85 L - 88 - 88L - 88LC

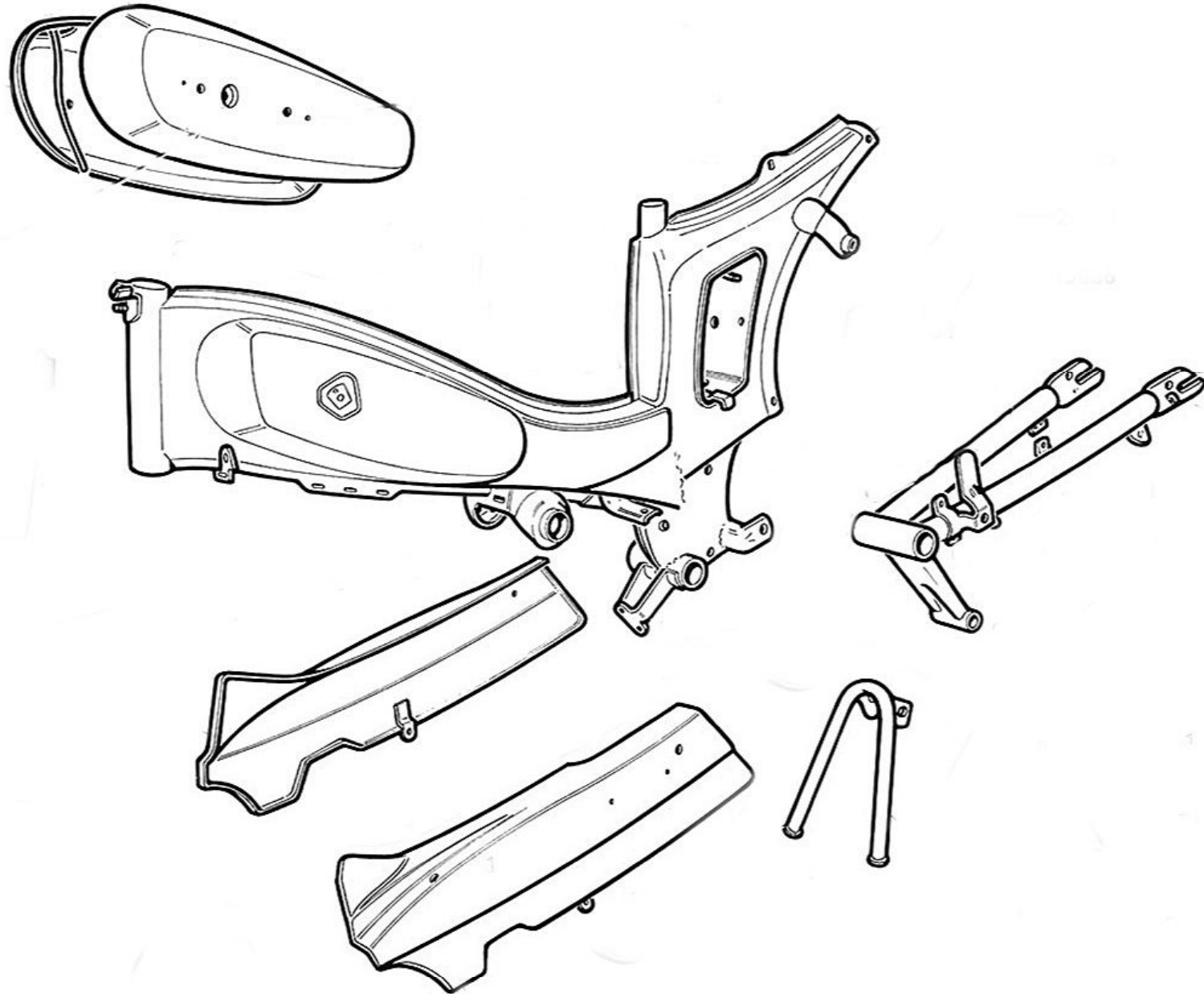

# MOBYLETTE

Types 85 N - 88

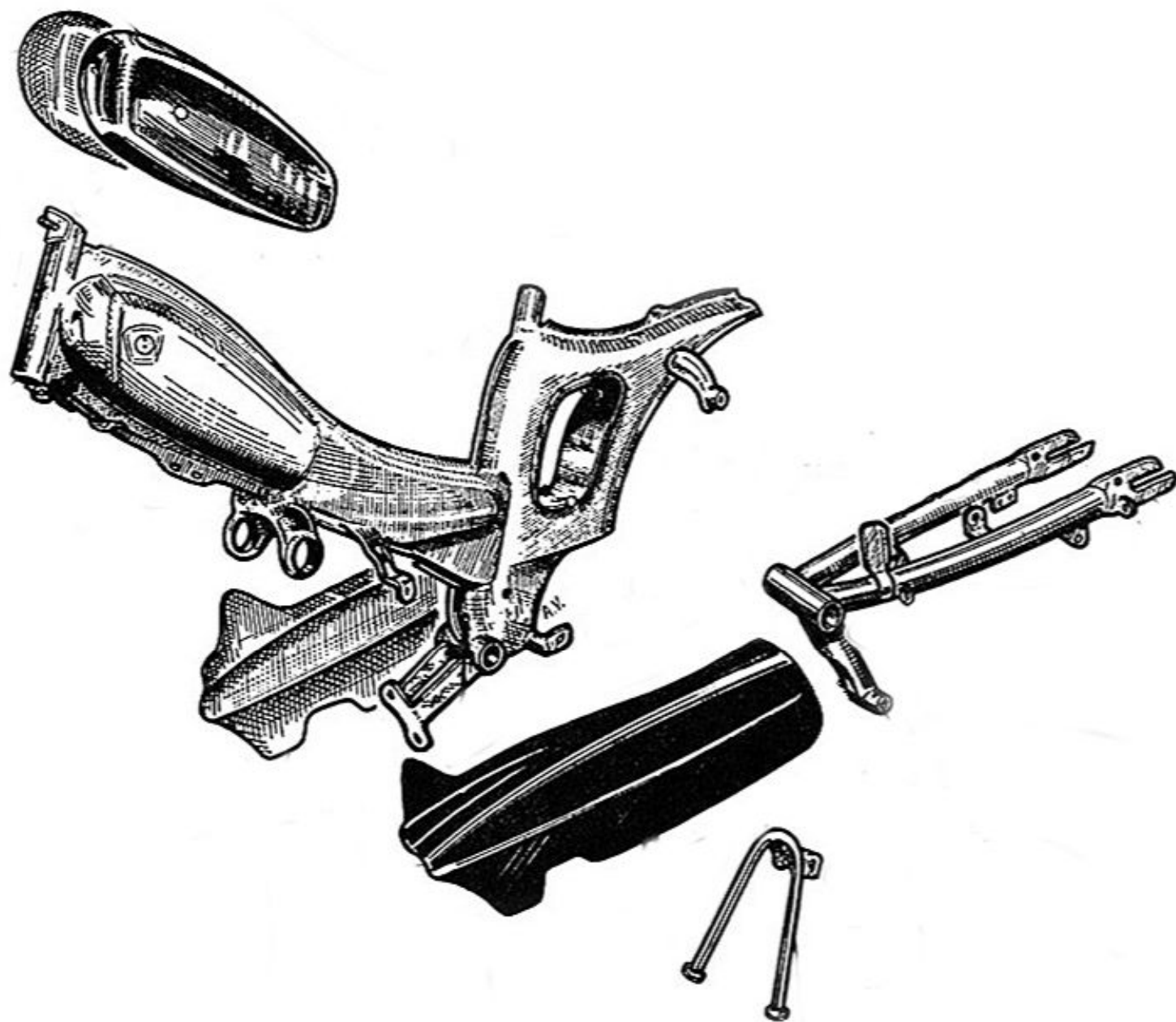

# CADRE - BRAS OSCILLANT - BÉQUILLE

## 881P

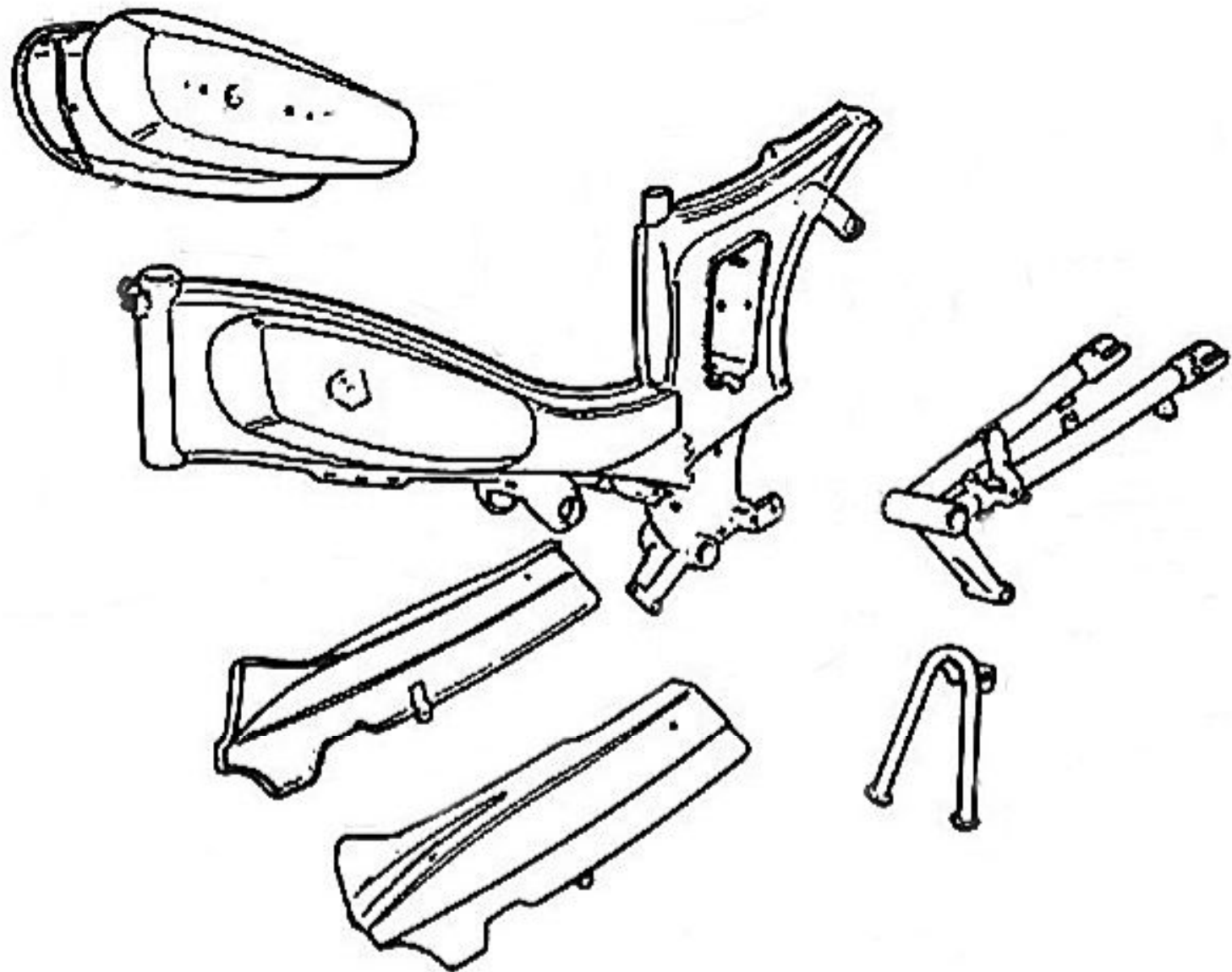

# Différentes version du type 881 avec ou sans enjoliveurs de réservoir

## CADRE - 881P

25862	SE	Enjo D + G chromés.....
25863	SE	Monogrammes D + G « MOTOBECAANE »..

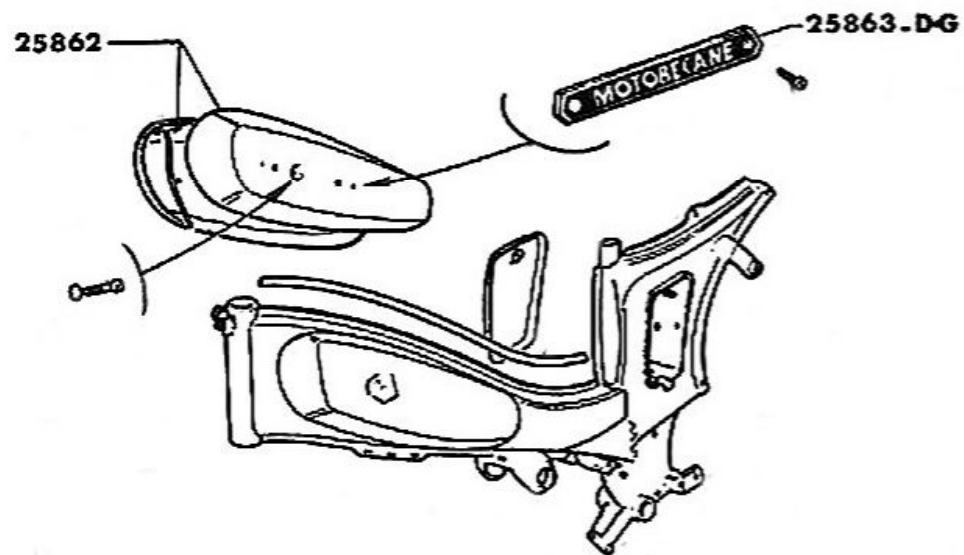

## CADRE - 881 Collection

REP N°PIECE	DESIGNATION	QTE
17	DANS JEU DE DECORS 32985	2

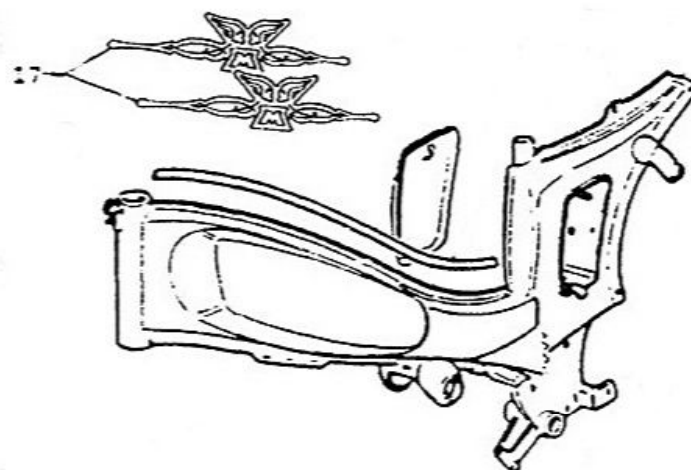

## CADRE - 881U et La Poste

REP	N°PIECE	DESIGNATION	QTE	REMARQUE
17	26793	MONOGRAMMES	2	881U 881UPUP 1994

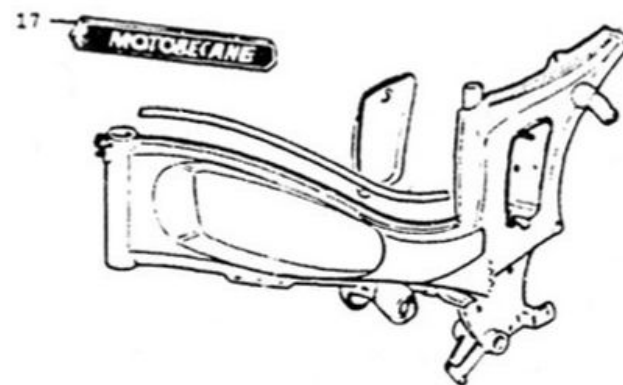

# MOBYLETTE

Types 92 - 92 N

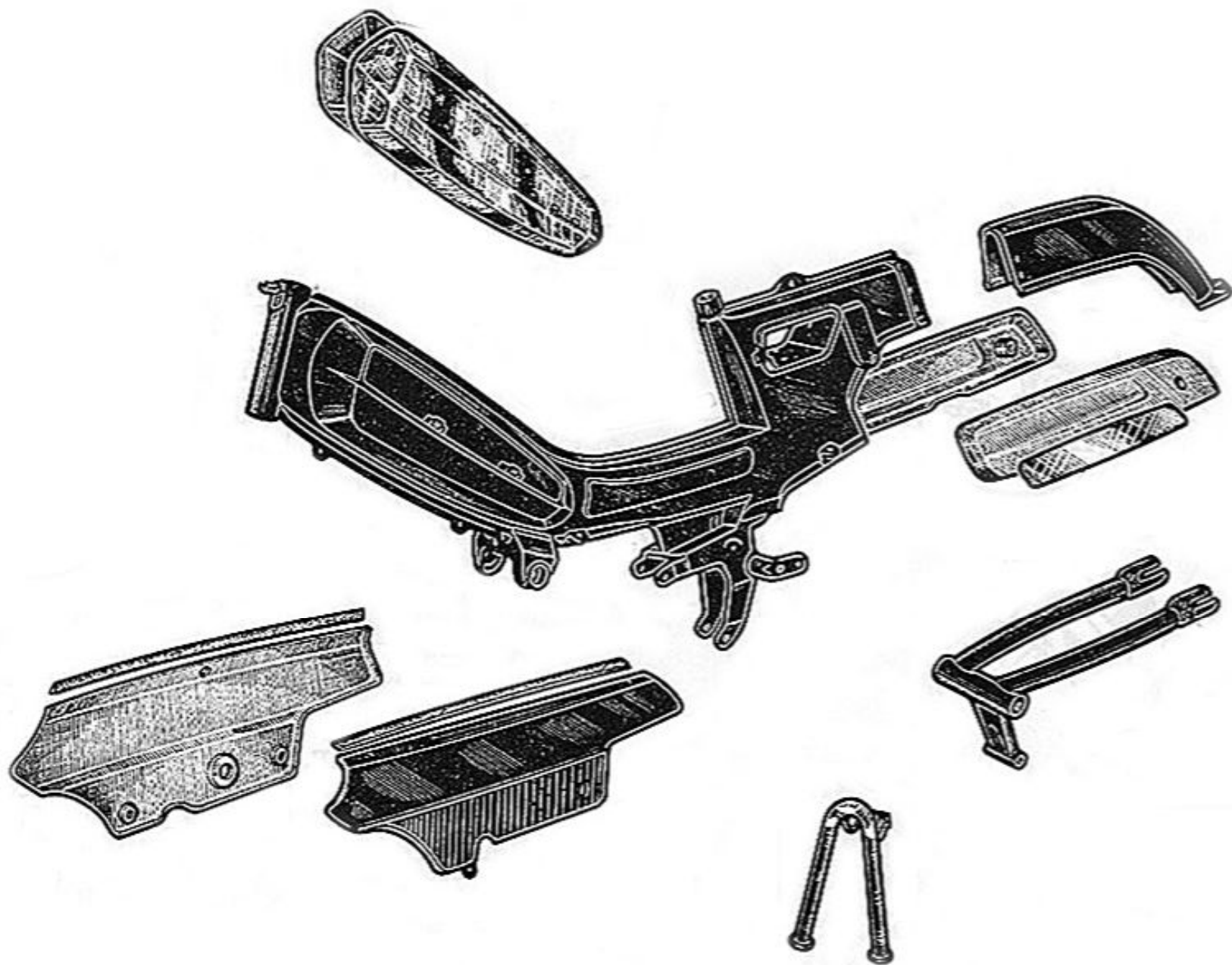

# MOBYLETTE type 95TT

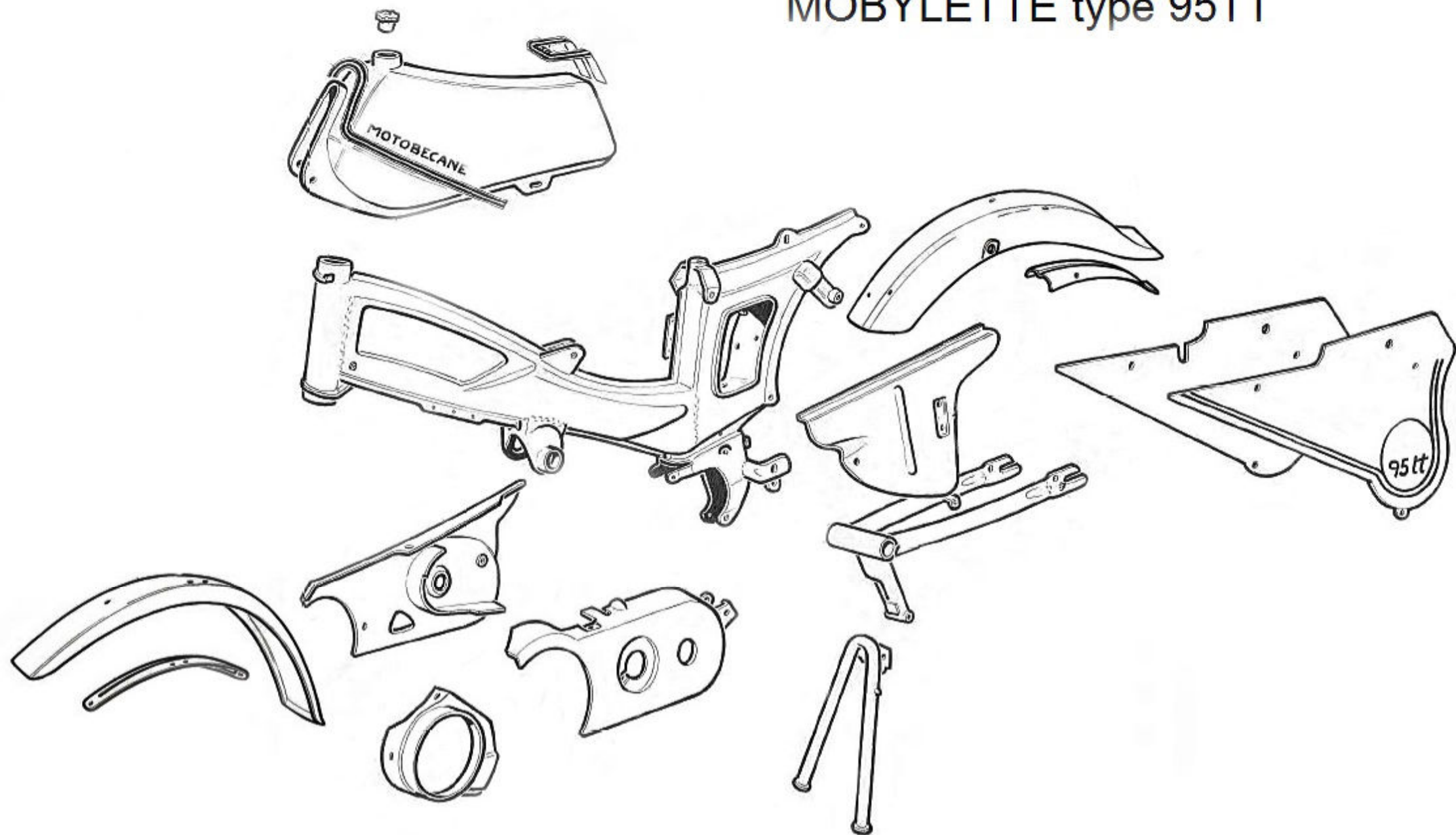



# MOTOBECANE 94 TT é







MOTOBECANE 99 Z

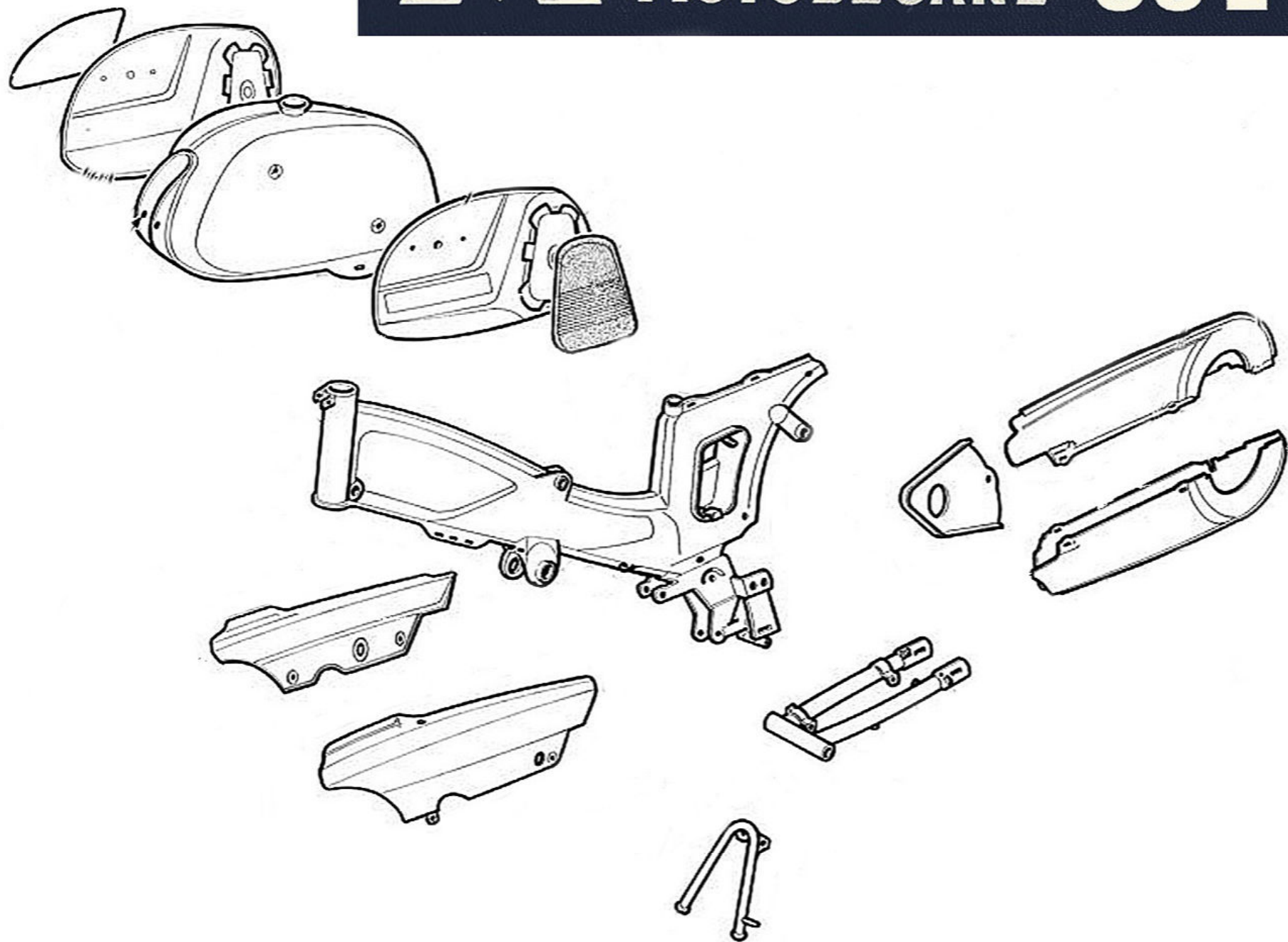

## PIECES POUR TRANSFORMATION DE MACHINES SERIE EN VERSION MOBCROSS

### 40-50

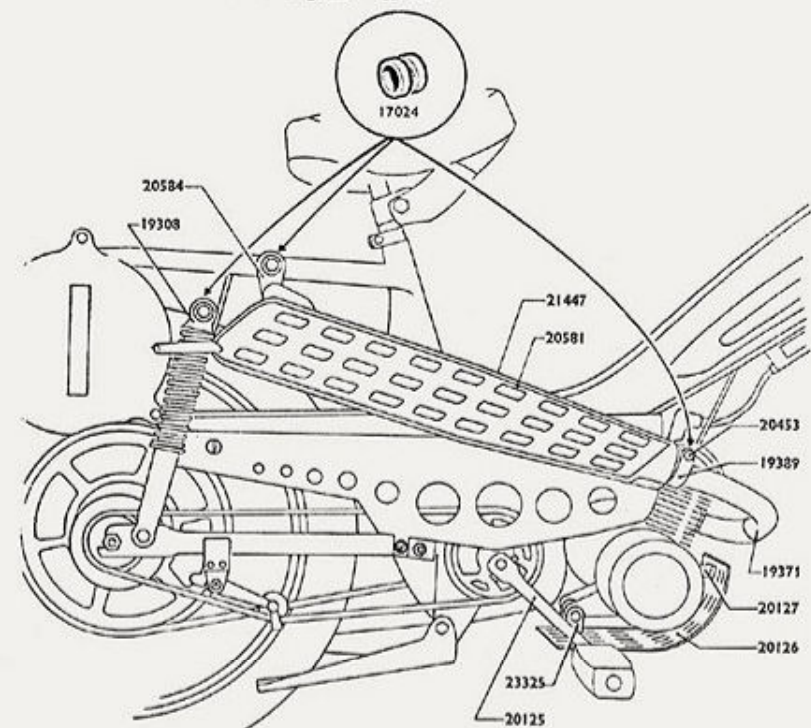

### 85-88-89

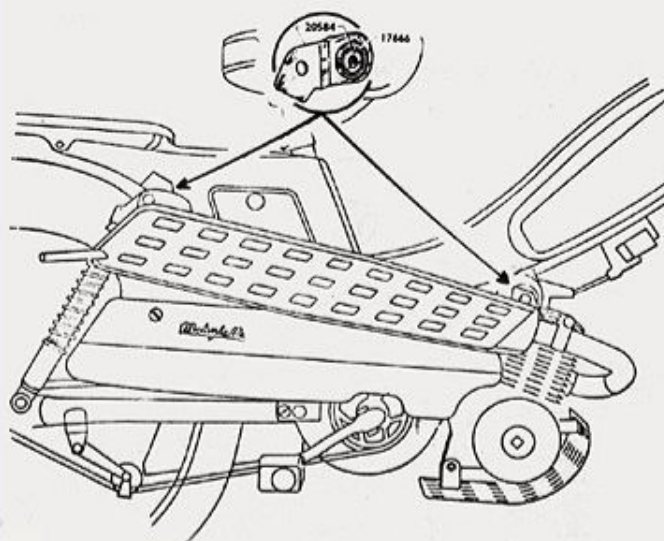

En 85-88-89 nécessité de cambrer la manivelle du plateau à la cote indiquée au croquis.



### 92

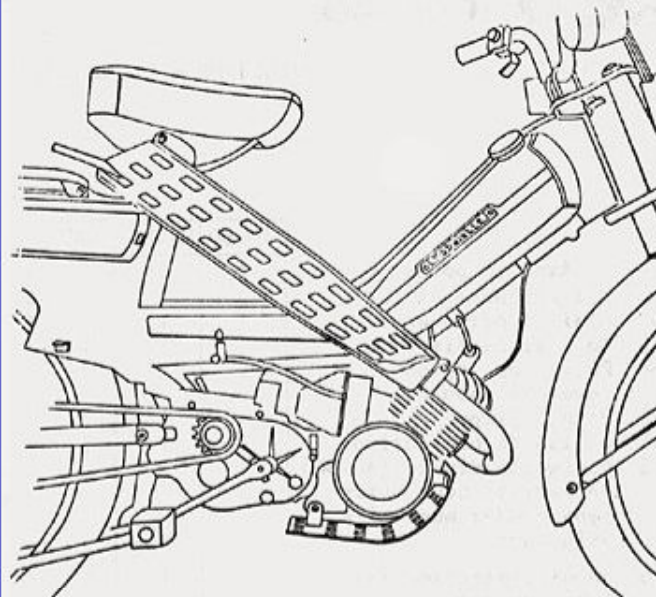

### MODIFICATION DU SABOT-PROTECTION MOTEUR

Couper 7,5 cm à partir de l'arrière

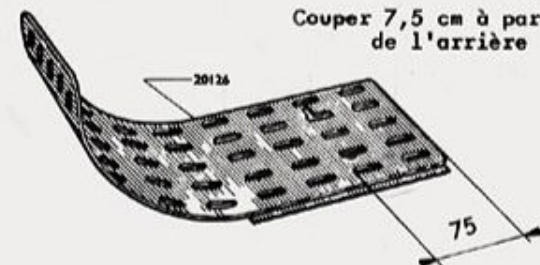

PIECES DESTINEES A ETRE COMMERCIALISEES POUR L'OPERATION MOBCROSS

DESIGNATION	Réf. P.D	Quant	40 50	85 88 89	92
Pneus à tétines	22434	2	2-1/2 X 17 TT	2-1/4 X 18 TT	2-1/4 X 18 TT
Guidon 94 TT	19375	1	adaptable	adaptable	adaptable
Pot échappement 94 TT complet			adaptable sans problème, fixation sur axe sup. moteur et sur essort. arrière nécessité adapter manivelle 94 TT Réf 20125	adaptable fixation sur axe sup. moteur et sur essort. arrière Nécessité couder la manivelle droite	adaptable, fixation sur axe sup. moteur et sur selle Nécessité rallonger axe fixation selle
- cintre	19371	1			
- pot	21447	1			
- grille	20581	1			
- collier fixation	19389	1			
- patte support	20584	1			
- axe fixation mot.	20453	1			
- frein avant	18837	1			
- joint élastique	20582	1			
APORTISSEUR 94 TT	19308	2	adaptable sauf 40	adaptable	adaptable
Sabat protection 94 TT	20126	1	adaptable	adaptable	adaptable
- patte fixe AV.	20127	1	Couper sabot 7,5 cm en partant de l'arrière	Couper 7,5 cm en partant de l'arrière	Couper 7,5 cm en partant de l'arrière
- patte fixe AR.	23525	2			
Entretoise (amort. 4 fixation mot. 2 fixation pot 2) Couronne	17024	8	42 dents	Non prévu	Non prévu
	23360	1			

Ci-dessus la liste des pièces destinées à être commercialisées pour l'adaptation d'un MOBCROSS. Elles sont pour la plupart issues de la 94 TT, elles peuvent être vendues individuellement et sont adaptables sur les différents modèles 40-50-85-88-92. Nous vous indiquons les modifications à effectuer dans notre documentation 579. Ces pièces ne sont pas imputées pour nos brevets (sauf les pneus Michelin), elles correspondent à la nomenclature du MOBCROSS que nous avons fabriqué à titre d'exemple.

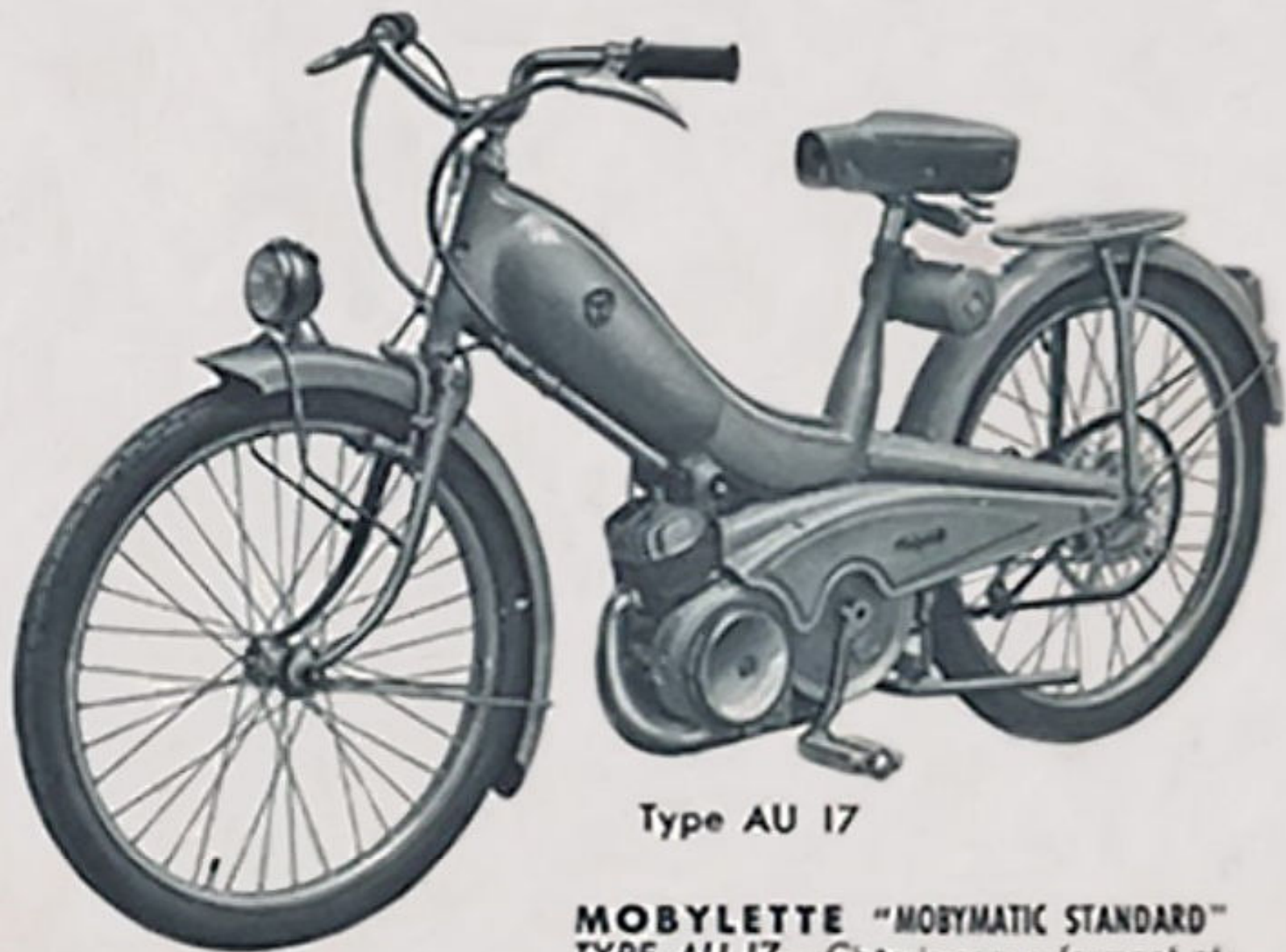

Type AU 17

**MOBYLETTE "MOBYMATIC STANDARD"**  
**TYPE AU 17** - Châssis-coque formant réservoir d'essence (capacité 4 L.  $\frac{1}{2}$ ) - double embrayage automatique "**DIMOBY**" - **changement de vitesse automatique "MOBYMATIC"** (breveté S. G. D. G.) - pneumatiques de 23X2 freins AR à tambour.

AV3 ou AU3

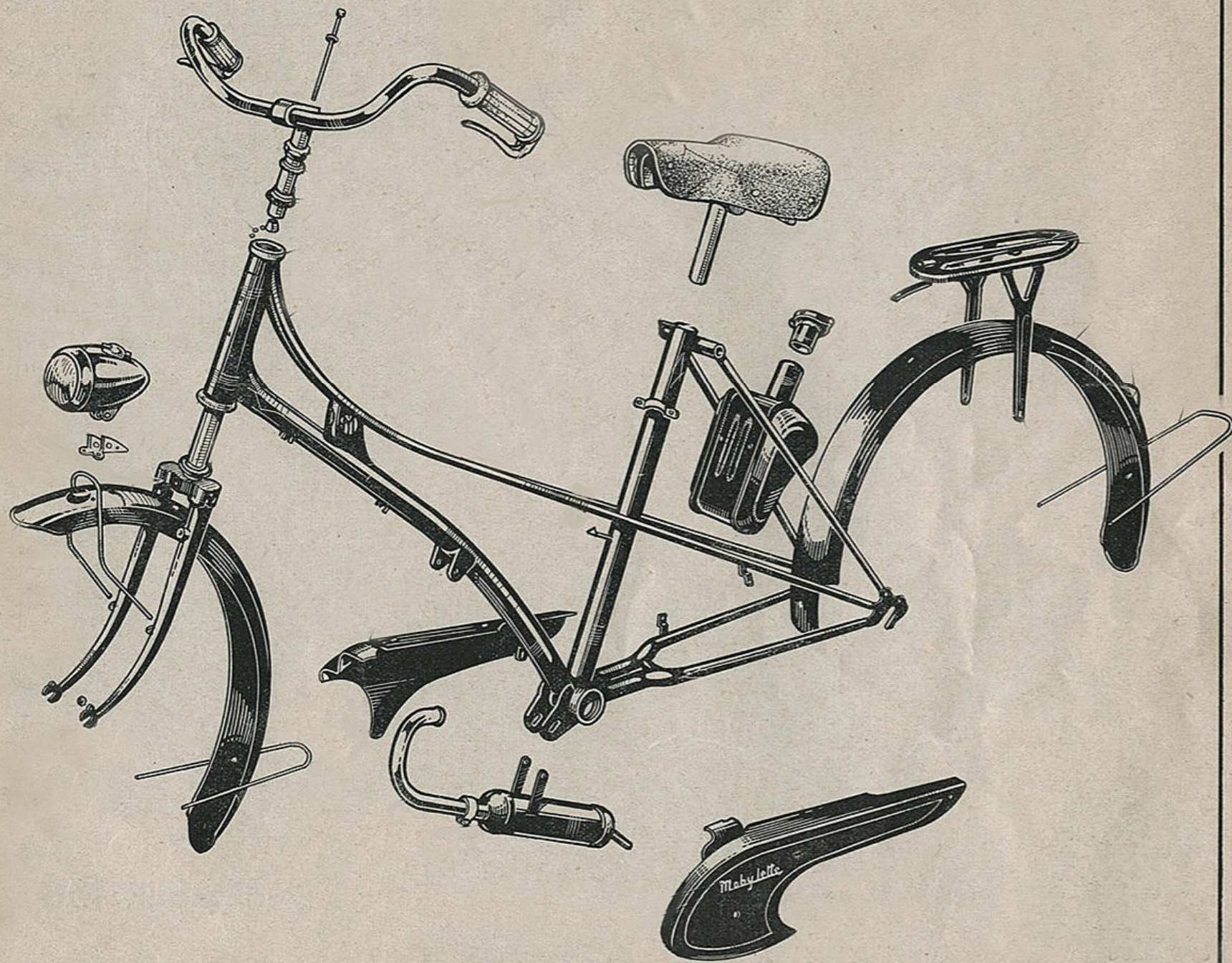

# 2 versions de cadres AV3 selon le type de frein utilisé

CADRE			
Cadre prévu pour freins randonneur .....	1	265001	=
— — — — — AR cantilever .....	1	265001/E	=

frein randonneur: un seul cable tire sur le palonnier central

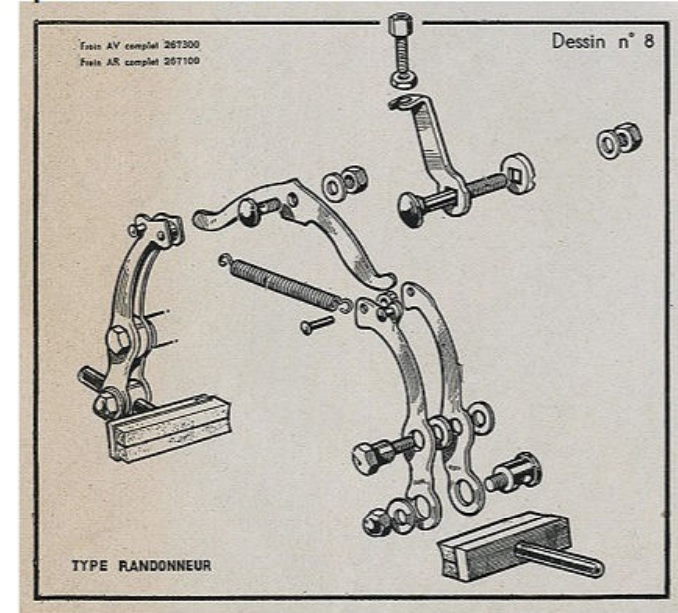

frein cantilever: le cable se dédouble afin de tirer sur les 2 patins

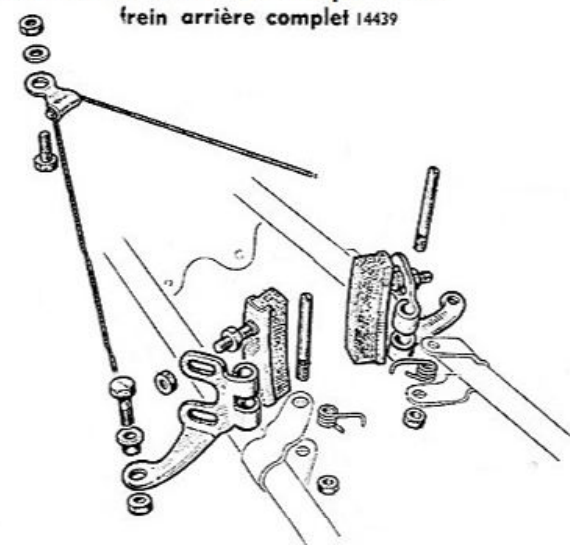

La 1ère version de cadre prévue pour les freins randonneur: le cable de frein traverse le tube support de selle

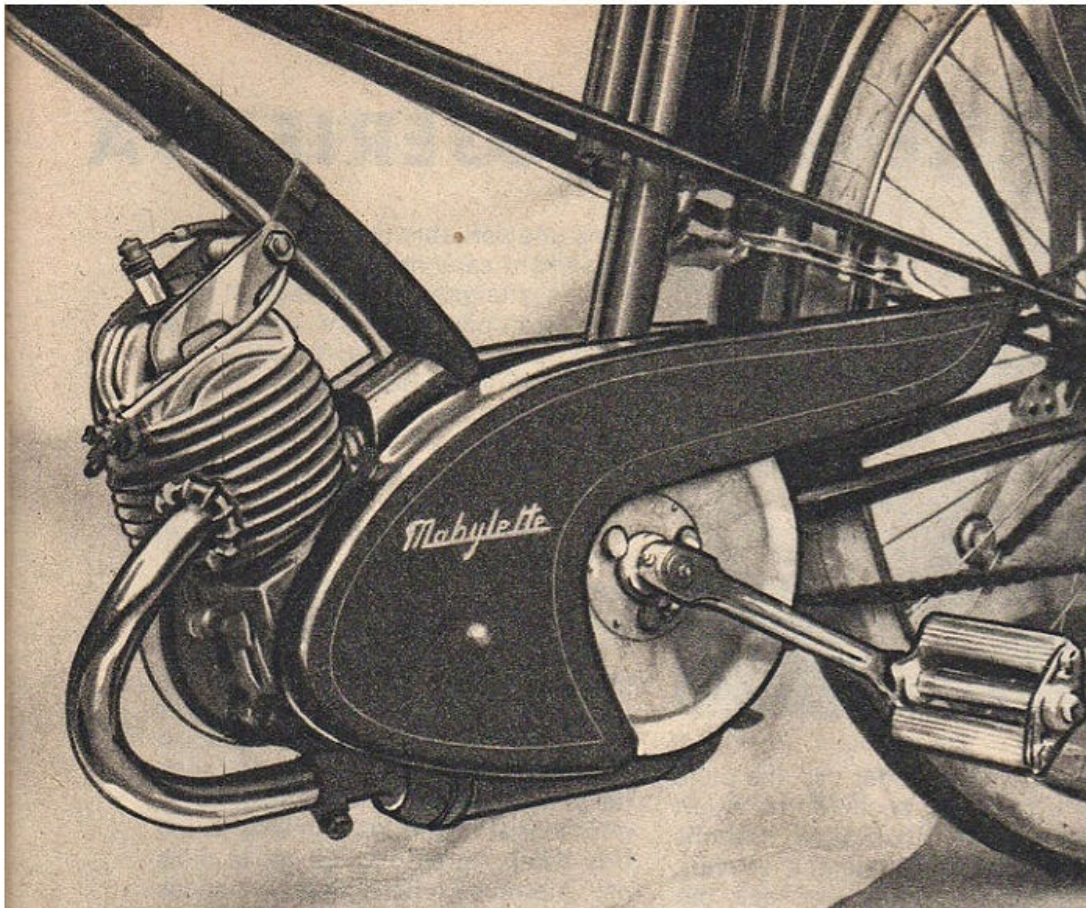
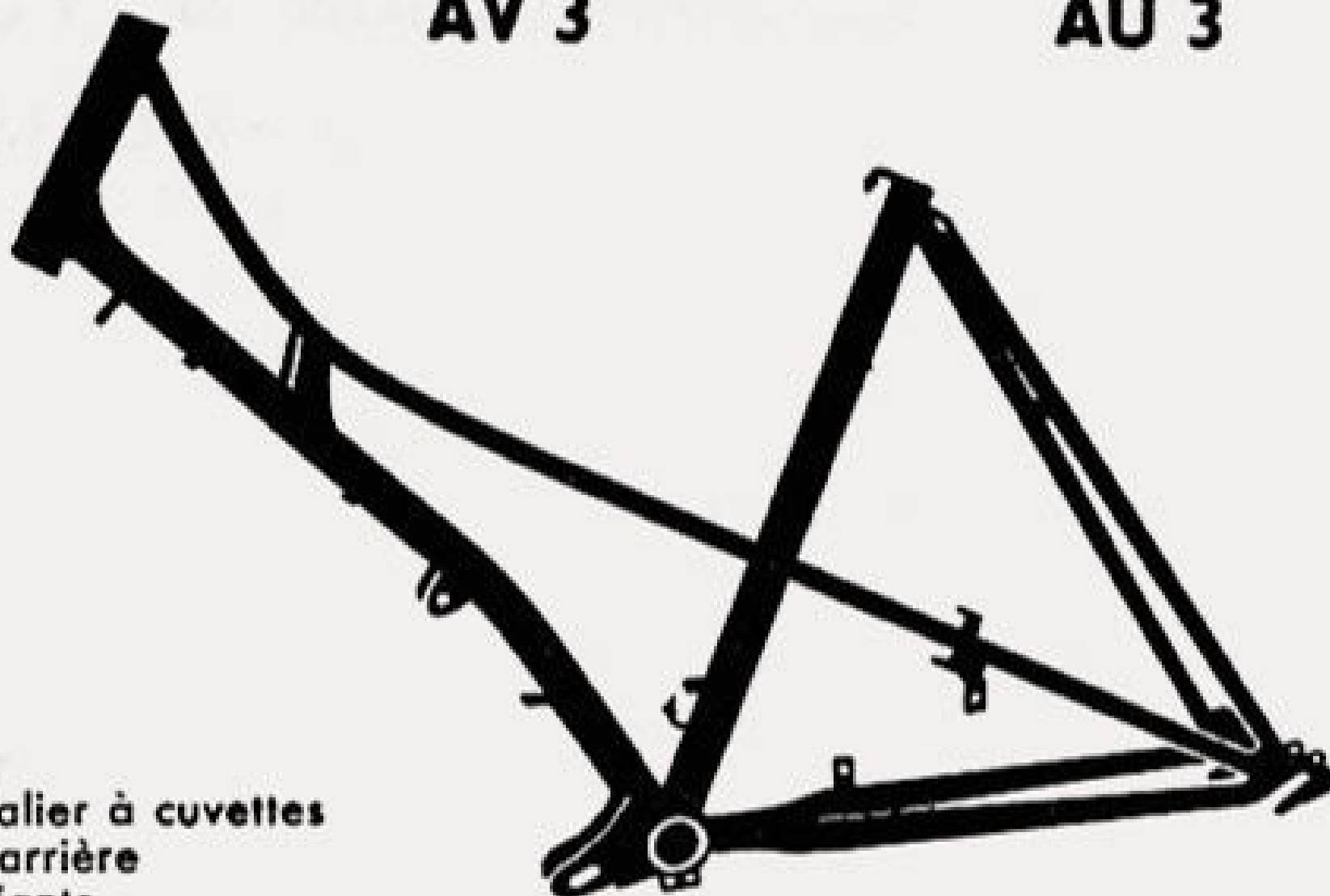

photo parue dans Motocycles 28 novembre 1949

cadre 2ème version 265001/E prévu pour frein cantilever

**AV 3**

**AU 3**



Boite pédalier à cuvettes  
Haubans arrière  
Frein sur jante

Teinte gris nuit N° 14184

# MOBYLETTE AV31 (version GAC)

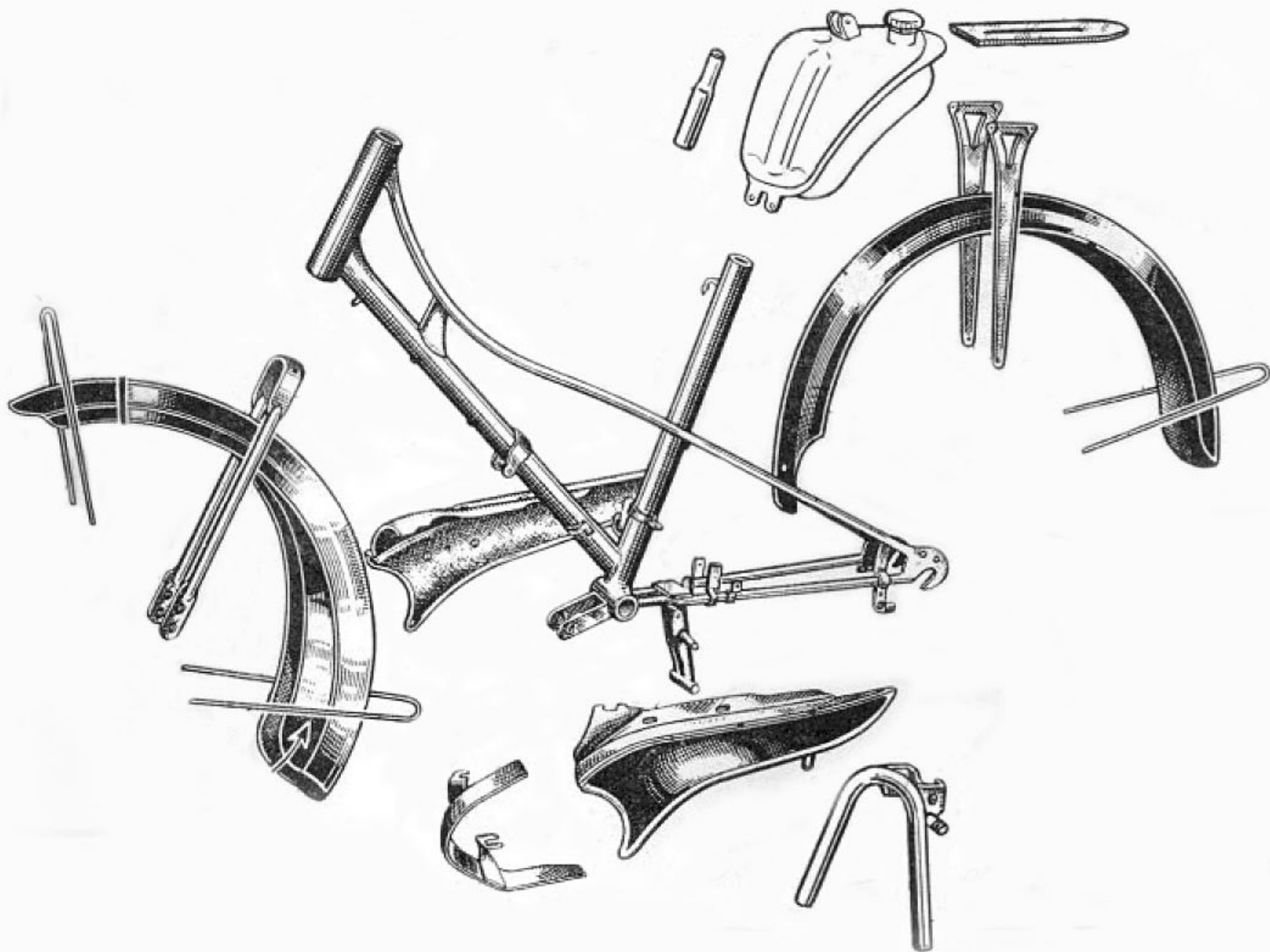

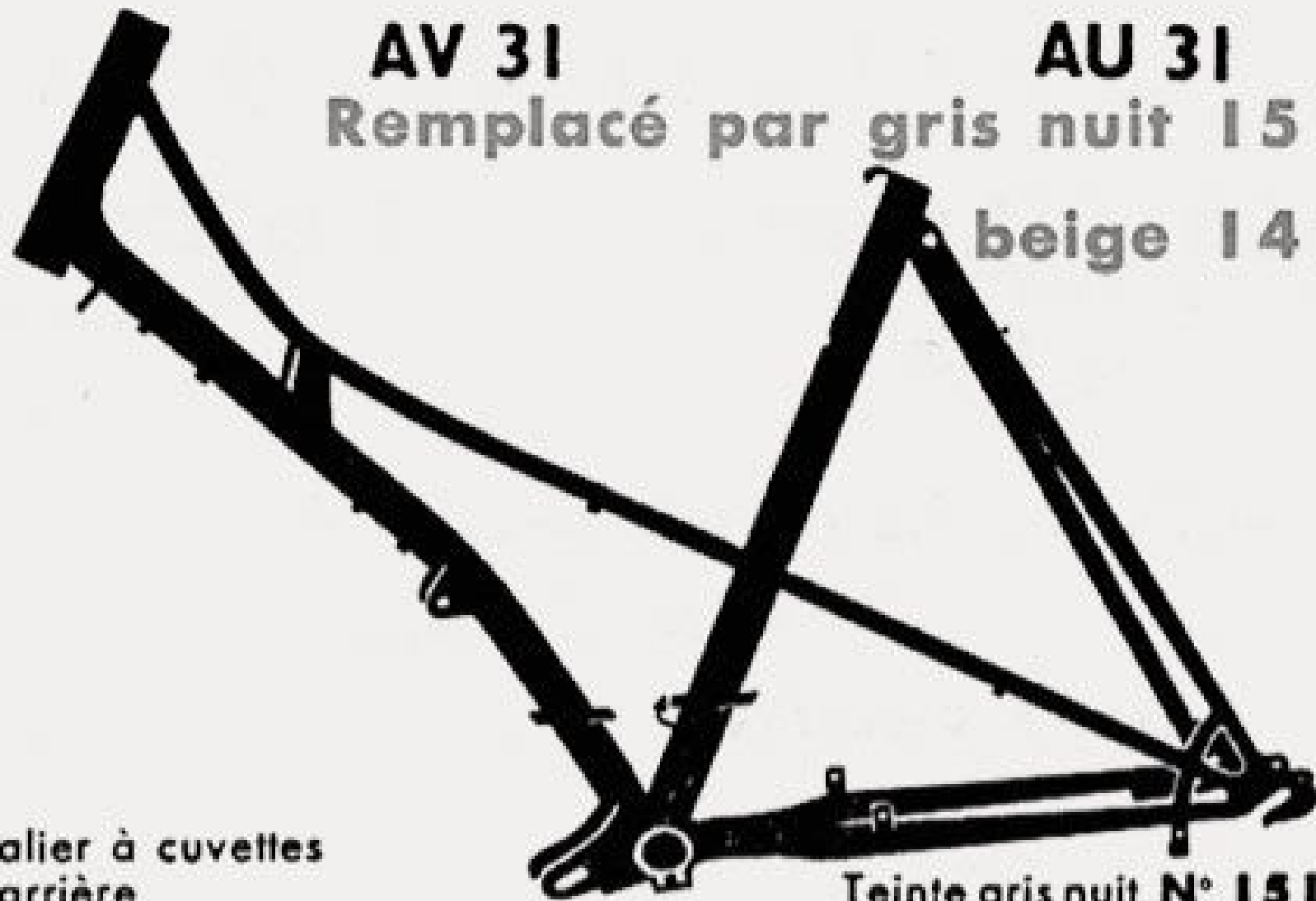

**AV 31**

**AU 31**

Remplacé par gris nuit 15115

beige 14185

Boite pédalier à cuvettes  
Haubans arrière  
Patte pour frein tambour arrière

Teinte gris nuit N° 15114

Teinte beige N° 15113



**AV 31**  
**AV 33**

**AU 31**  
**AU 33**

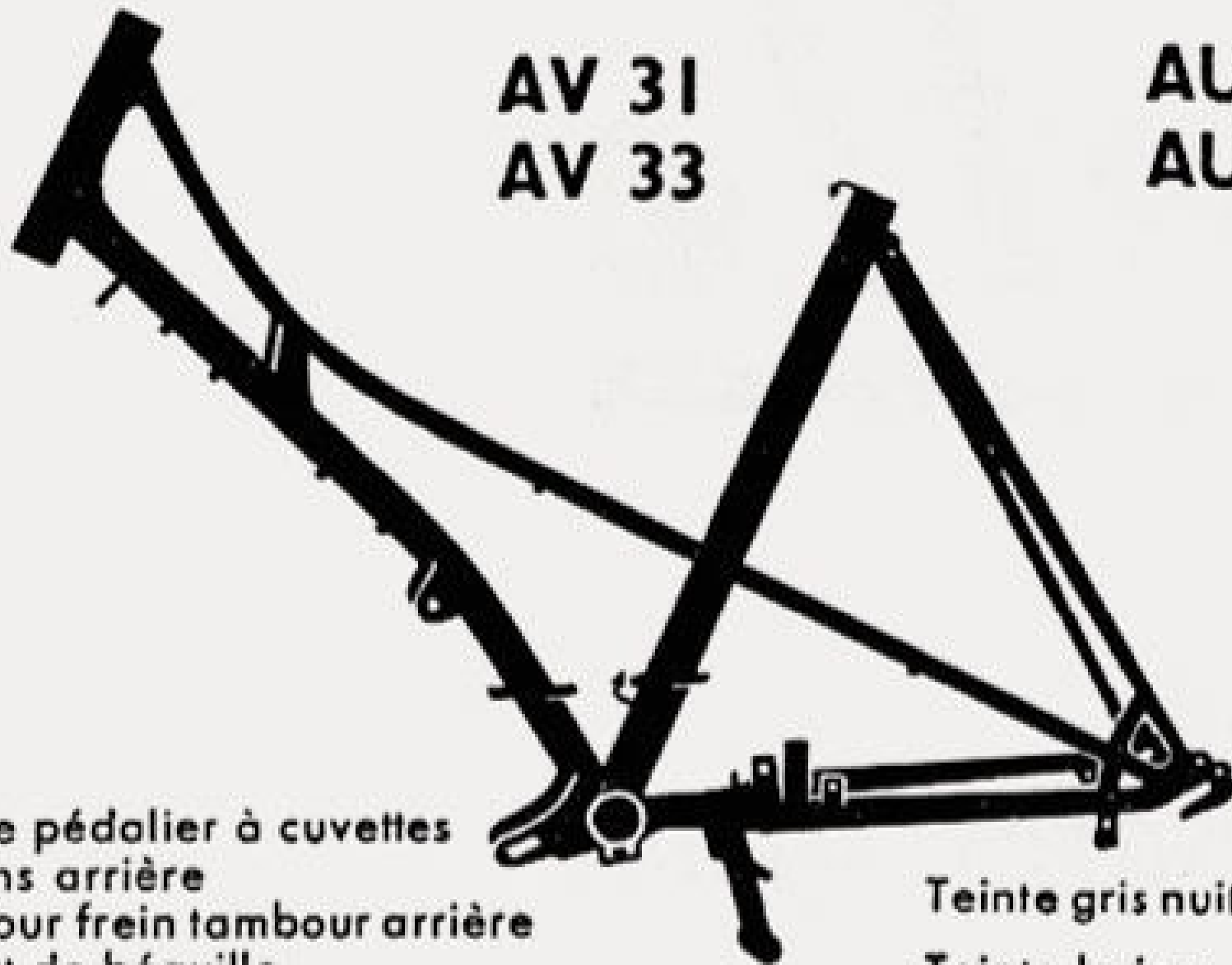

Boite de pédalier à cuvettes  
Haubans arrière  
Patte pour frein tambour arrière  
Support de béquille

Teinte gris nuit **N° 15115**  
Teinte beige **N° 14185**

**AV 31**  
**AV 33**

**AU 31**  
**AU 33**

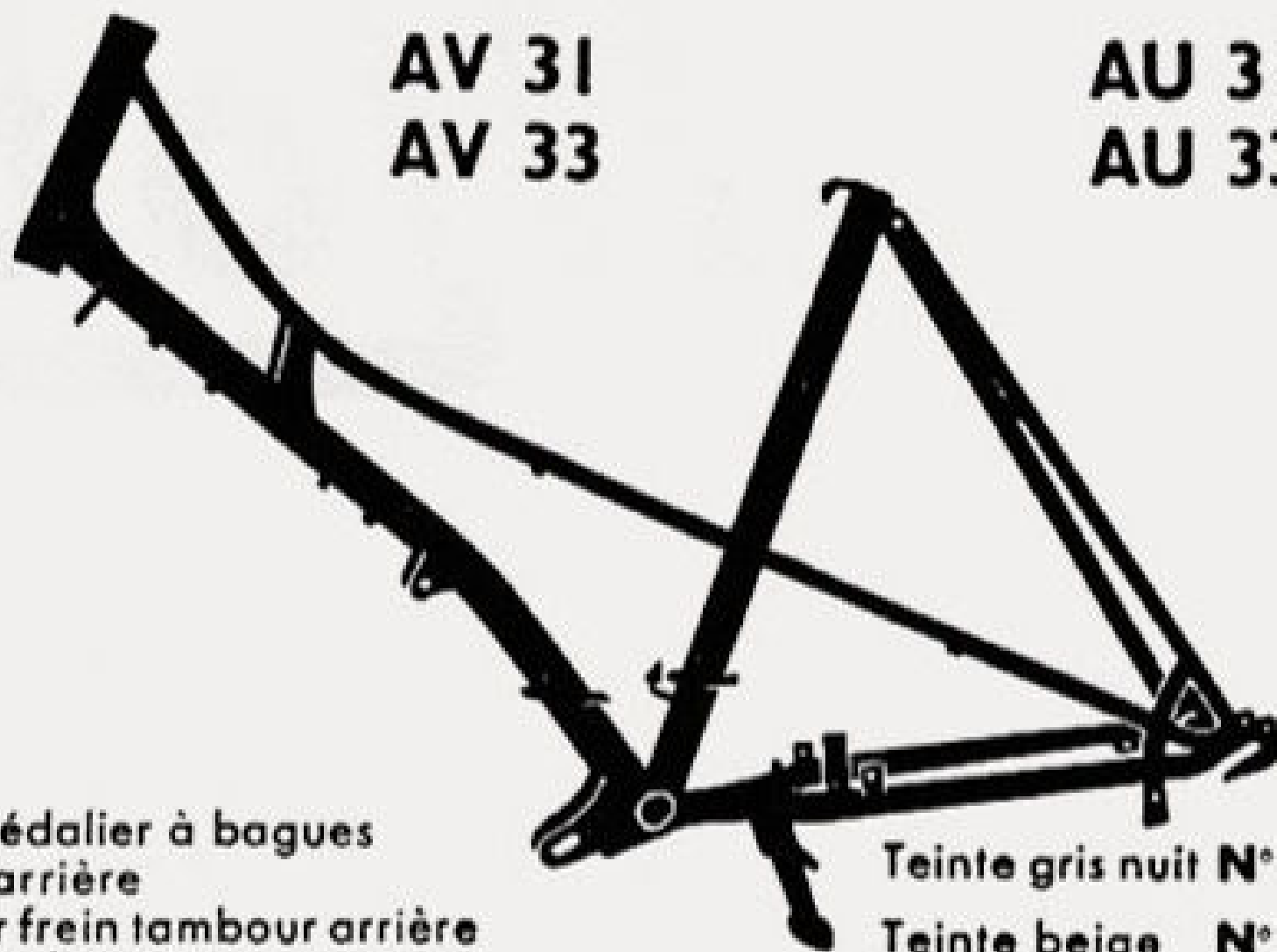

Boîte de pédalier à bagues  
Haubans arrière  
Patte pour frein tambour arrière  
Support de béquille

Teinte gris nuit N° 15116

Teinte beige N° 14190

Teinte mastic N° 14191

**AV 31**

**AV 33**

**AU 31**

**AU 33**

**Remplacé par gris nuit 16501  
mastic 15302**

**NOTA 1.**

**Boite de pédalier à bogues  
Sans hauban arrière  
Patte pour frein tambour arrière**

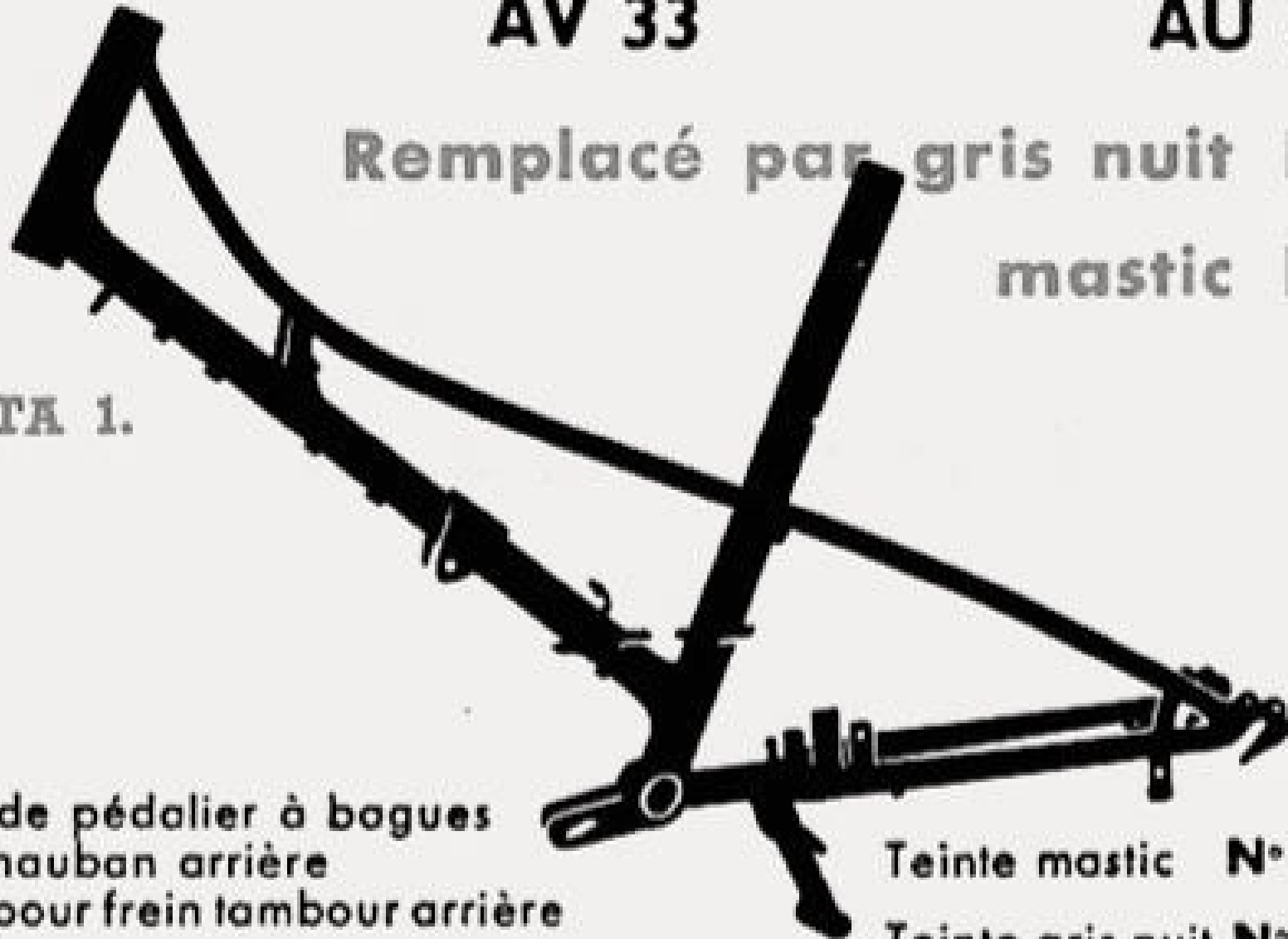

**Teinte mastic N° 14194**

**Teinte gris nuit N° 15117**

# MOBYLETTE

## Type AV 32 M ou AU 32 M

Reservoir nouveau modèle

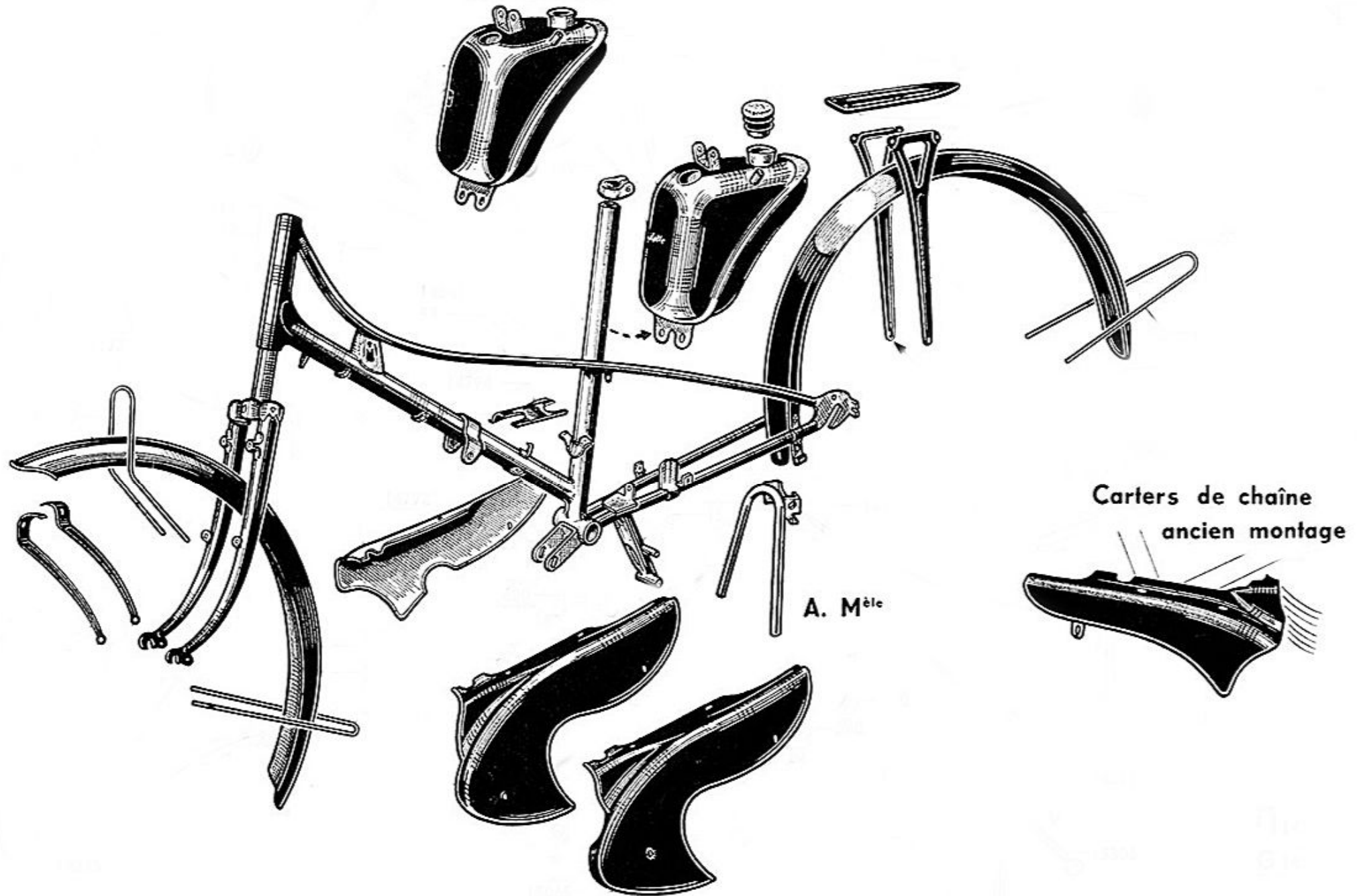

Carters de chaîne  
ancien montage

A. Mêle

**AV 32 M**

**AU 32 M**

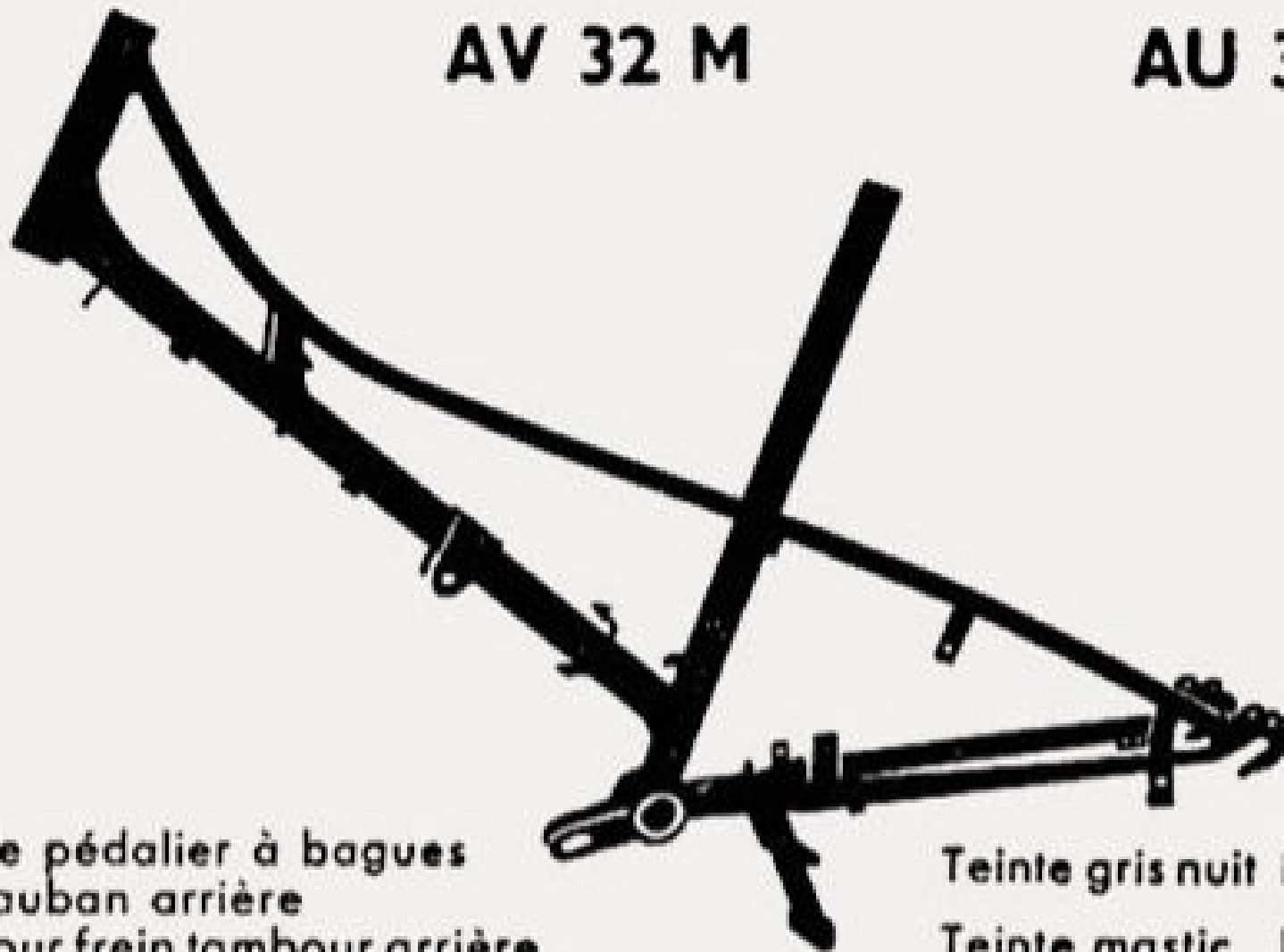

Boite de pédalier à bagues  
Sans hauban arrière  
Patte pour frein tambour arrière

Teinte gris nuit **N° 14871**

Teinte mastic **N° 14770**

**AV 32 M**

**AV 33**

**AV 34**

**AV 51**

**AV 54**

**AU 32 M**

**AU 33**

**AU 34**

**AU 51**

**AU 54**

**Remplacé par 15302**



Boite de pédalier à bogues  
Sans hauban arrière  
Patte pour frein tambour arrière  
Pattes pour nouv. carters de chaîne  
Pattes pour réglage roue arrière

Teinte mastic **N° 15084**

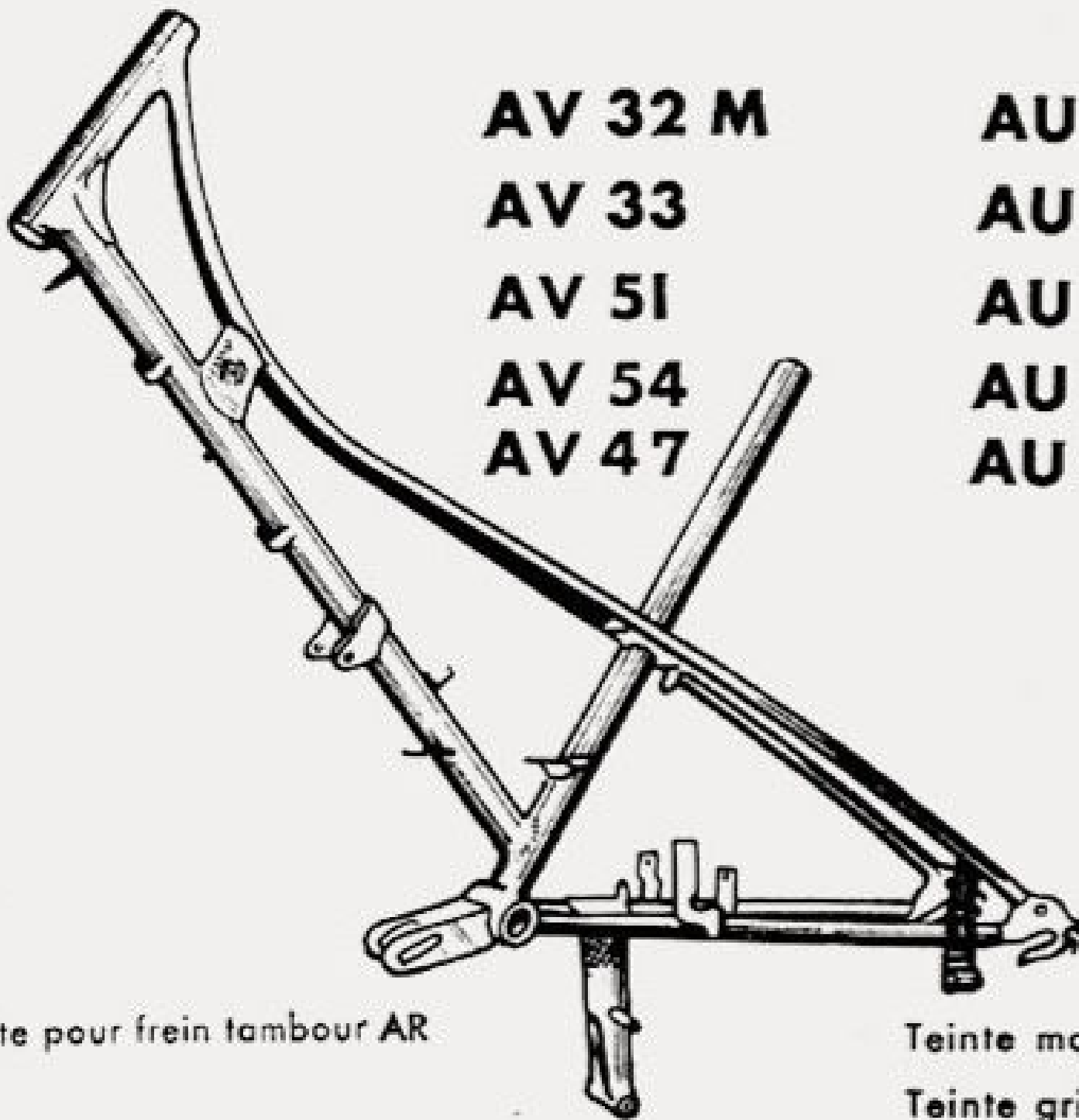

**AV 32 M**

**AV 33**

**AV 51**

**AV 54**

**AV 47**

**AU 32 M**

**AU 33**

**AU 51**

**AU 54**

**AU 47**

Patte pour frein tambour AR

Teinte mastic N° 15302

Teinte gris nuit N° 16501

# MOBYLETTE Type AV 32 S ou AU 32 S

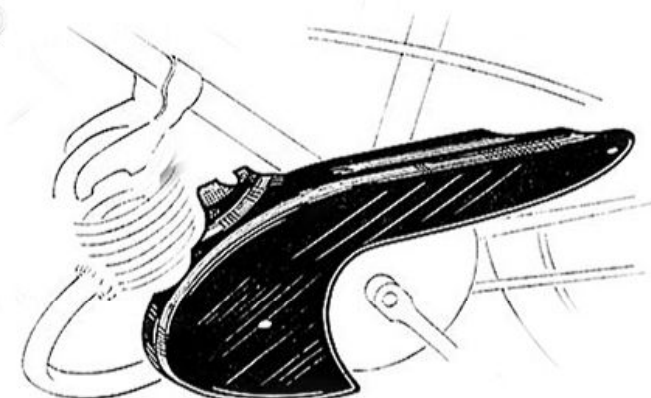
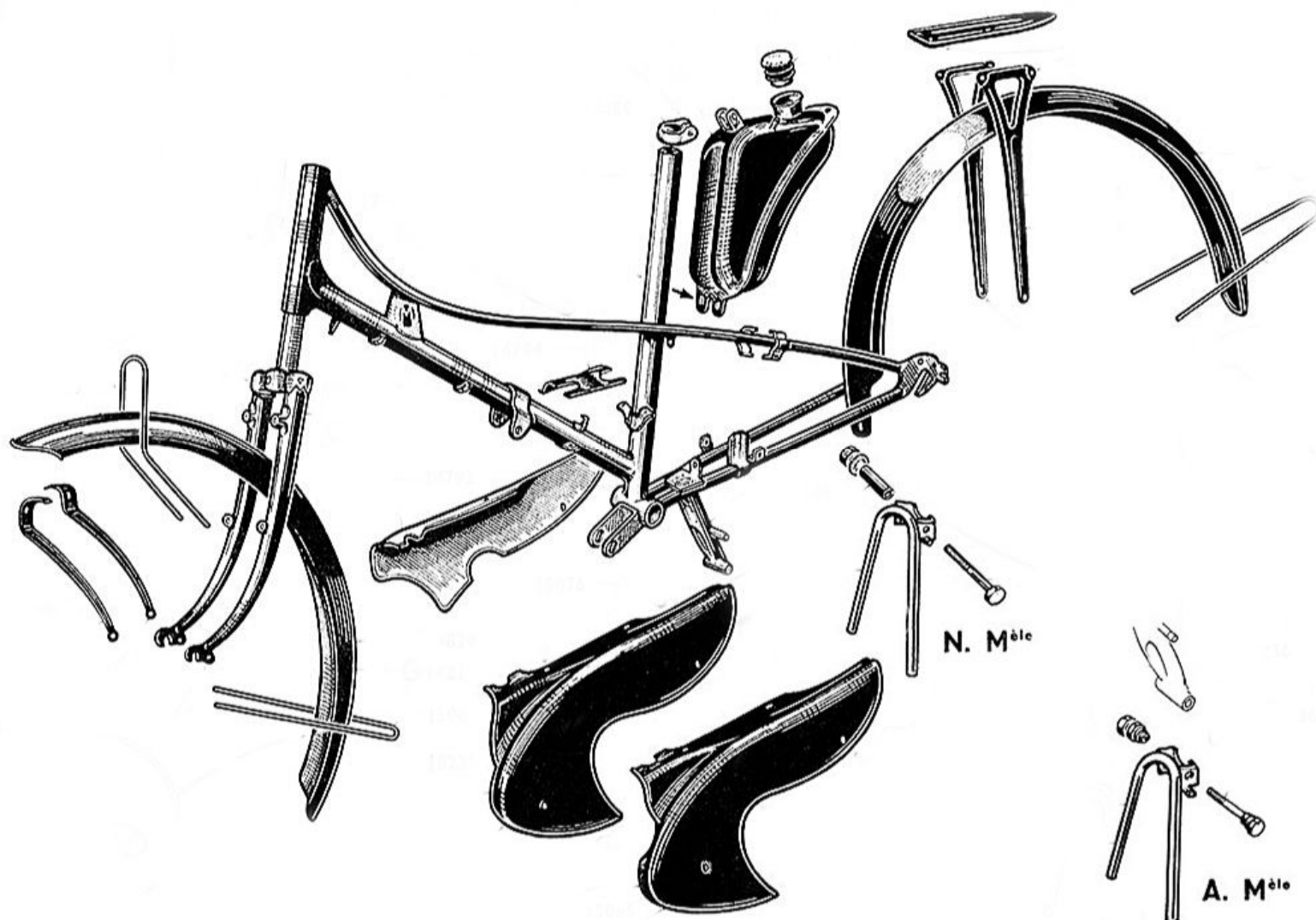

Carters de chaîne  
ancien montage



A. M<sup>le</sup>



**AV 32 S**

**AU 32 S**

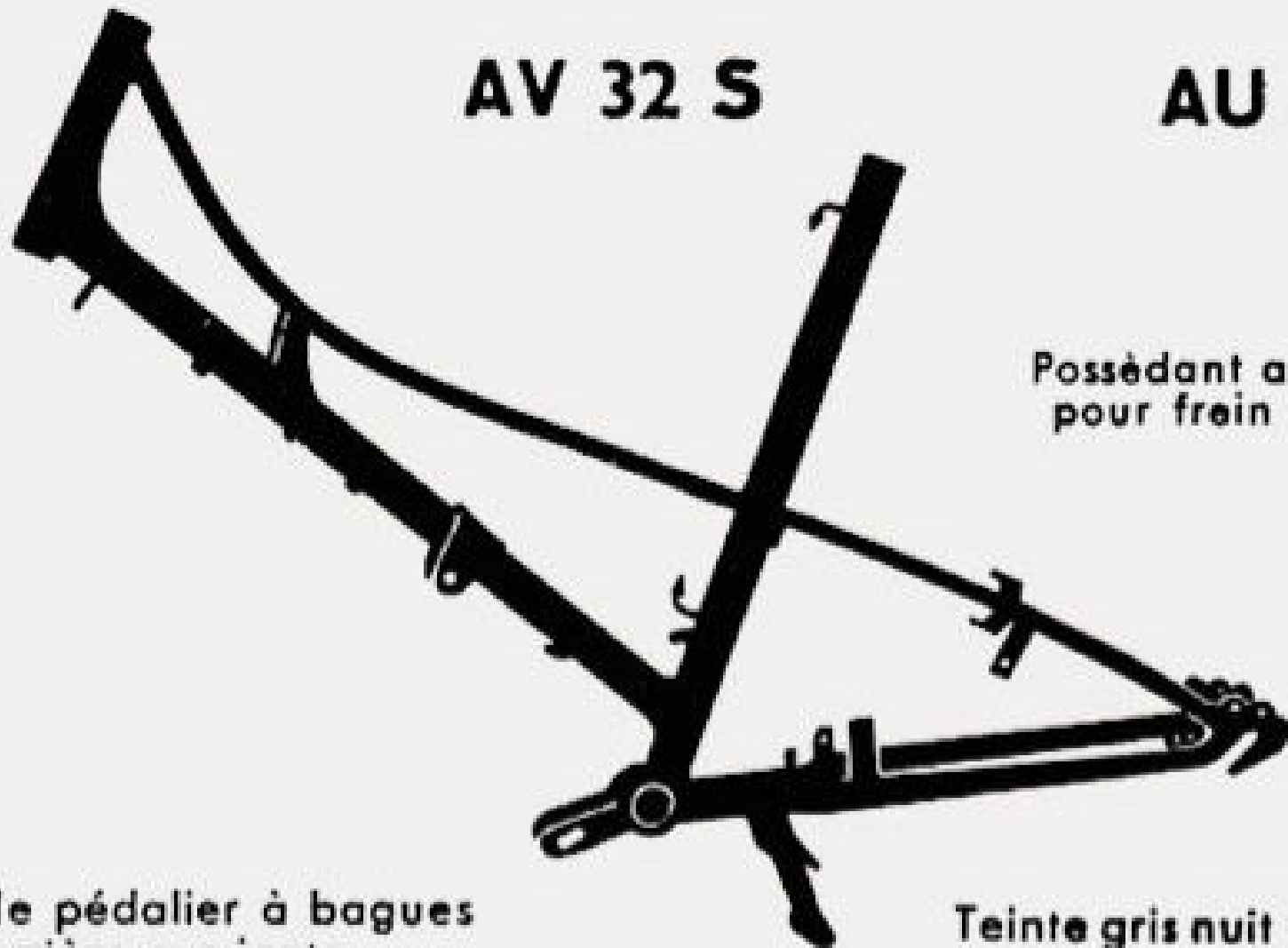

Possédant aussi patte  
pour frein tambour

Boite de pédalier à bagues  
Frein arrière sur jante  
Sans hauban arrière

Teinte gris nuit **N° 14188**

Teinte mastic **N° 14769**

**AV 32 S**

**AU 32 S**

Remplacé par 15304

Boite de pédalier à bagues  
Sans hauban arrière  
Frein arrière sur jante  
Patte pour réglage roue arrière  
Pattes pour nouv. carters de chaîne



Teinte mastic **N° 15085**

**AV 32 S**

**AU 32 S**

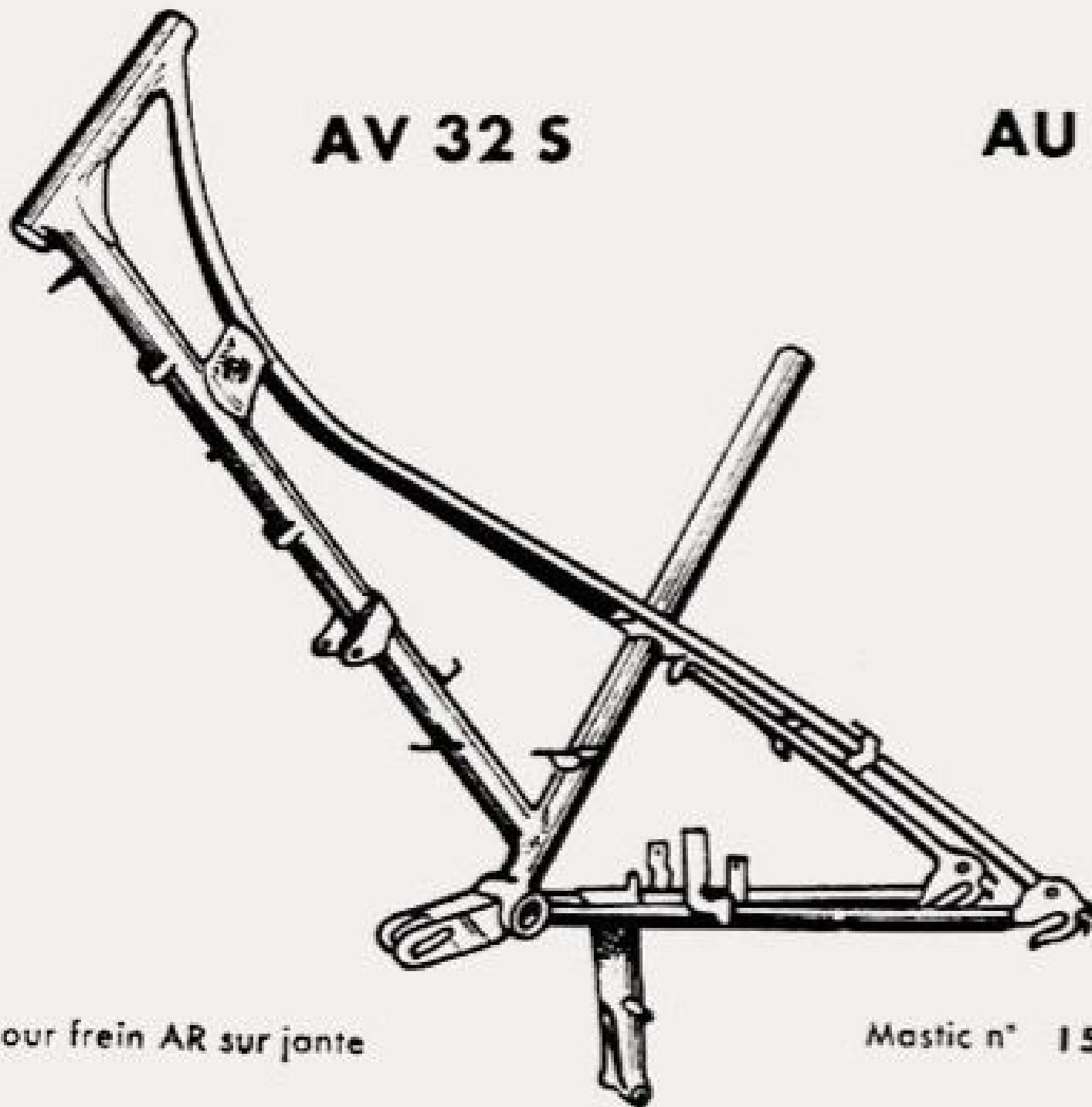

Pattes pour frein AR sur jante

Mastic n° 15304

**AV 32 U**

**AU 32 U**

Remplacé par gris nuit 14188

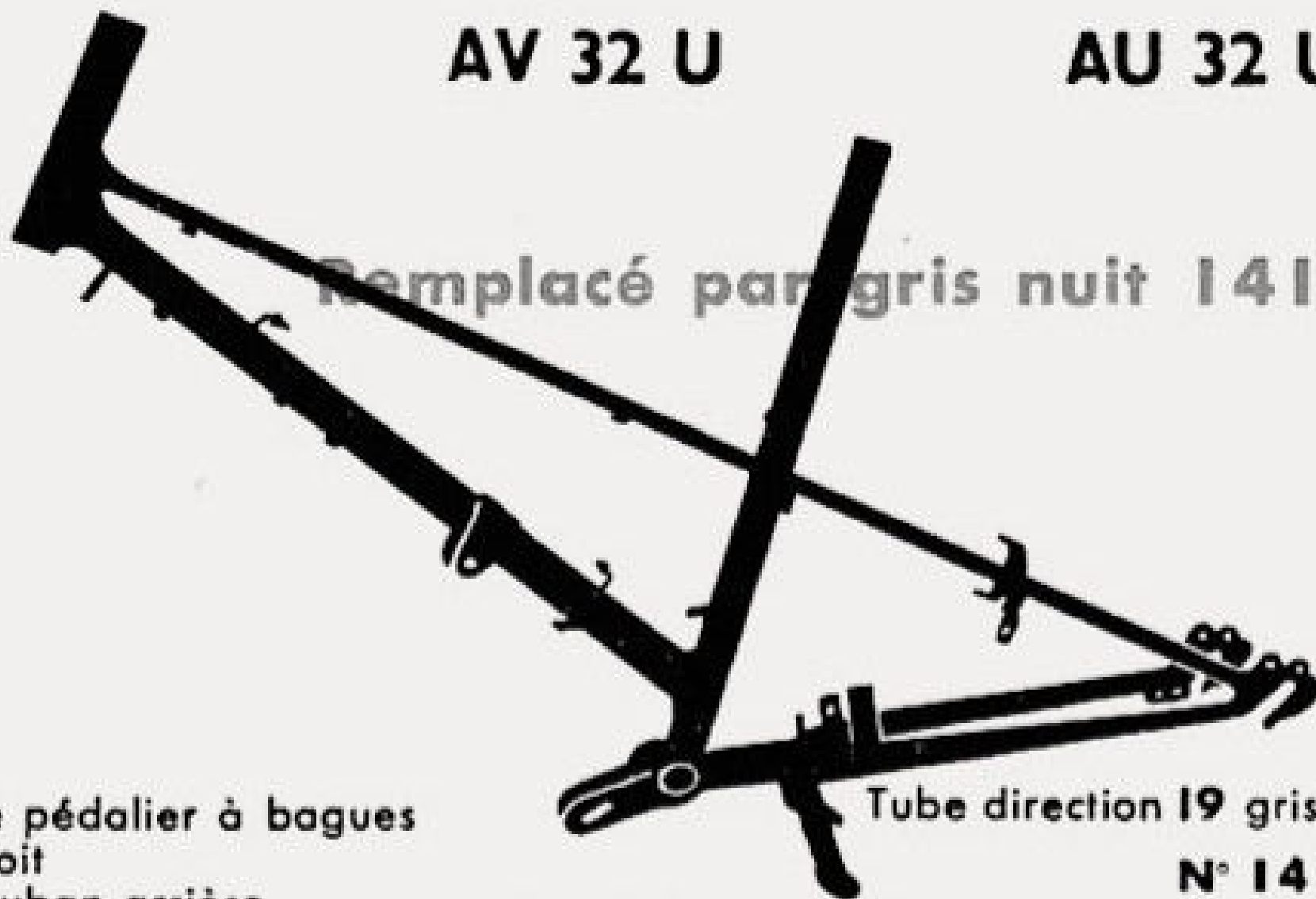

Boite de pédalier à bagues  
Tube droit  
Sans hauban arrière

Tube direction 19 gris nuit

**N° 14186**

Tube direction 21 gris nuit

**N° 14951**

**AV 32 U**

**AU 32 U**

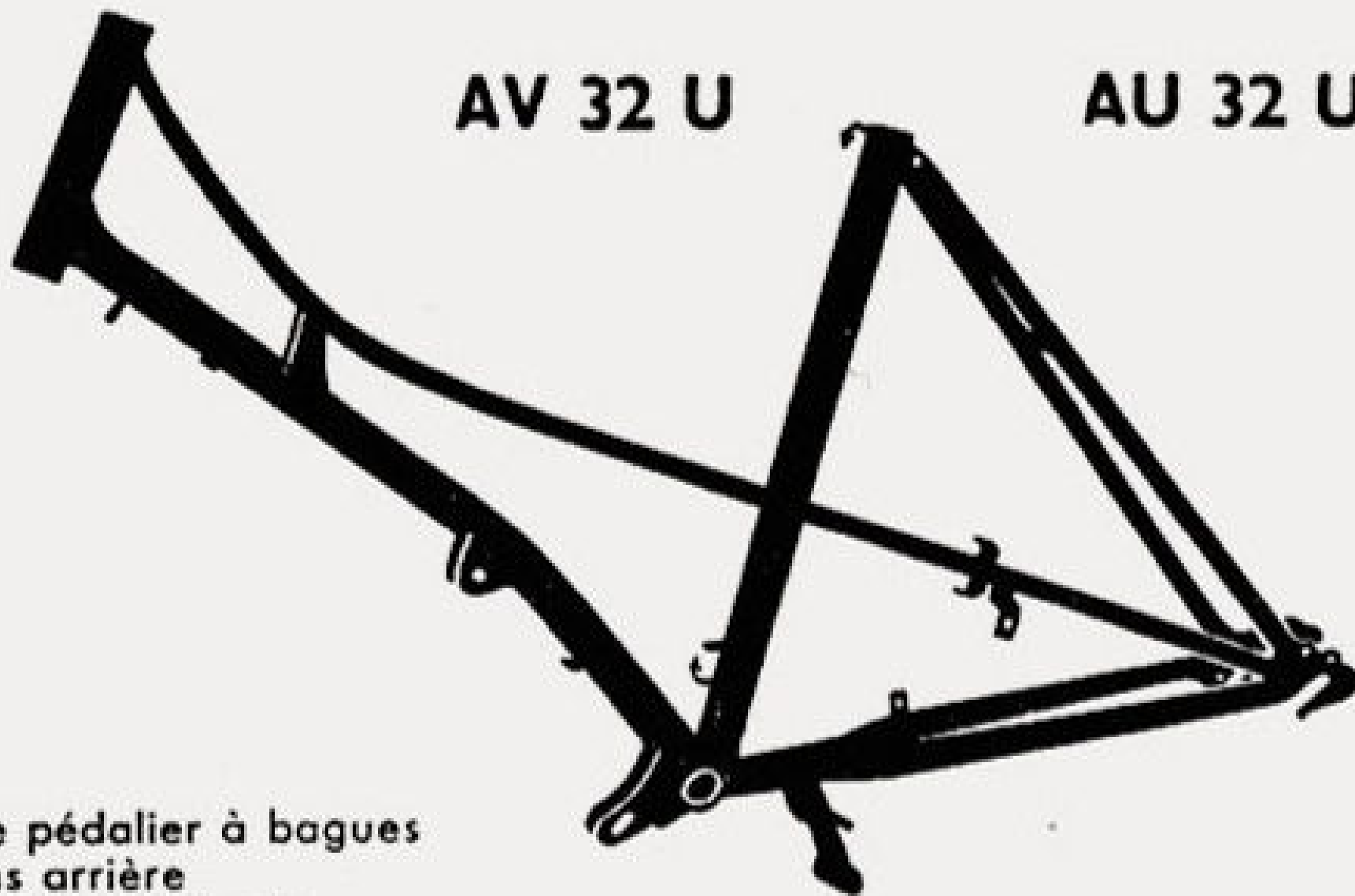

Boite de pédalier à bagues  
Haubans arrière  
Frein arrière sur jante

Teinte gris nuit N° 14952

# MOBYLETTE

Type AV 33 ou AU 33

ancien modèle



Carters de chaîne

ancien montage

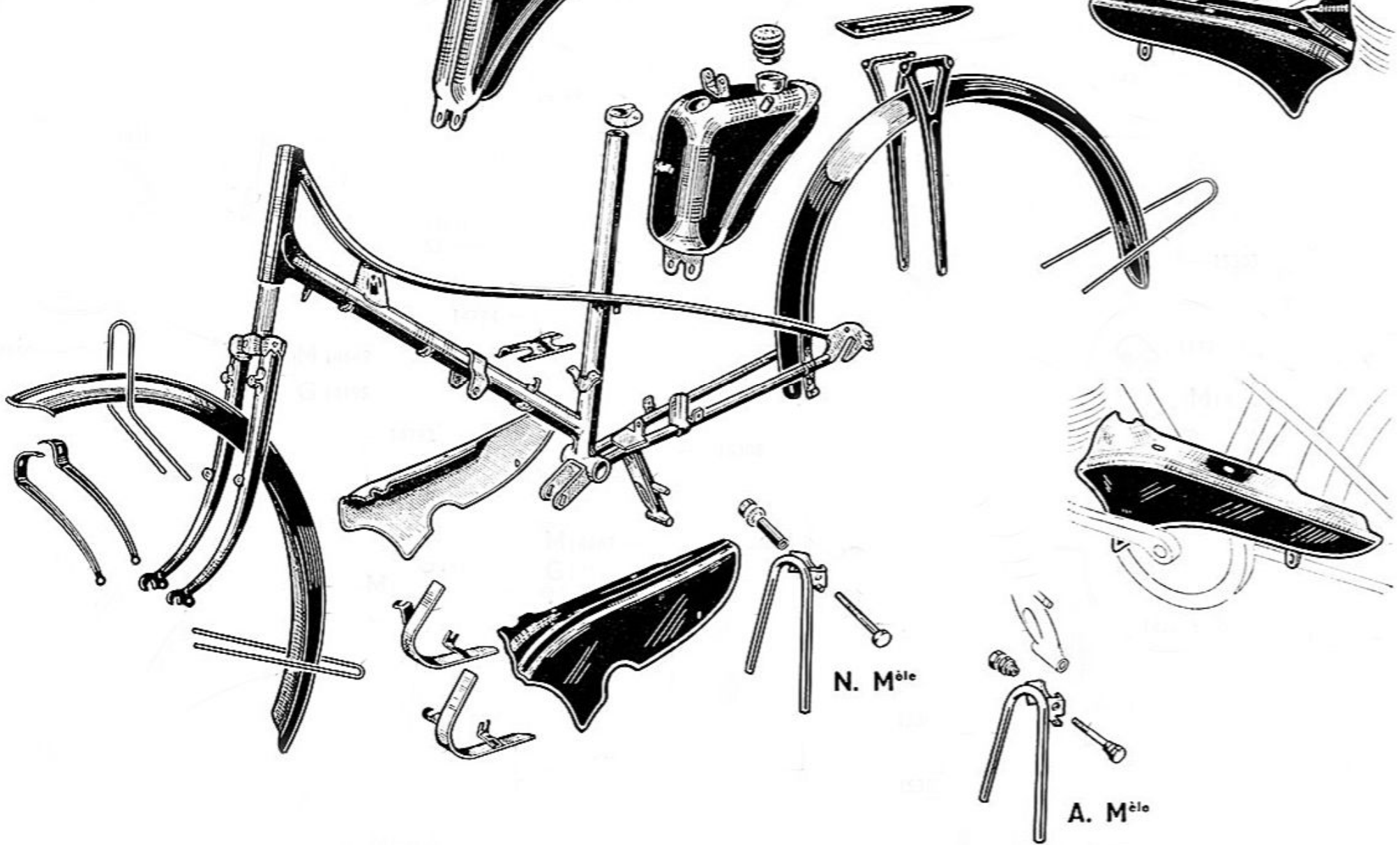

**MOBYLETTE**

Type AV 34 ou AU 34

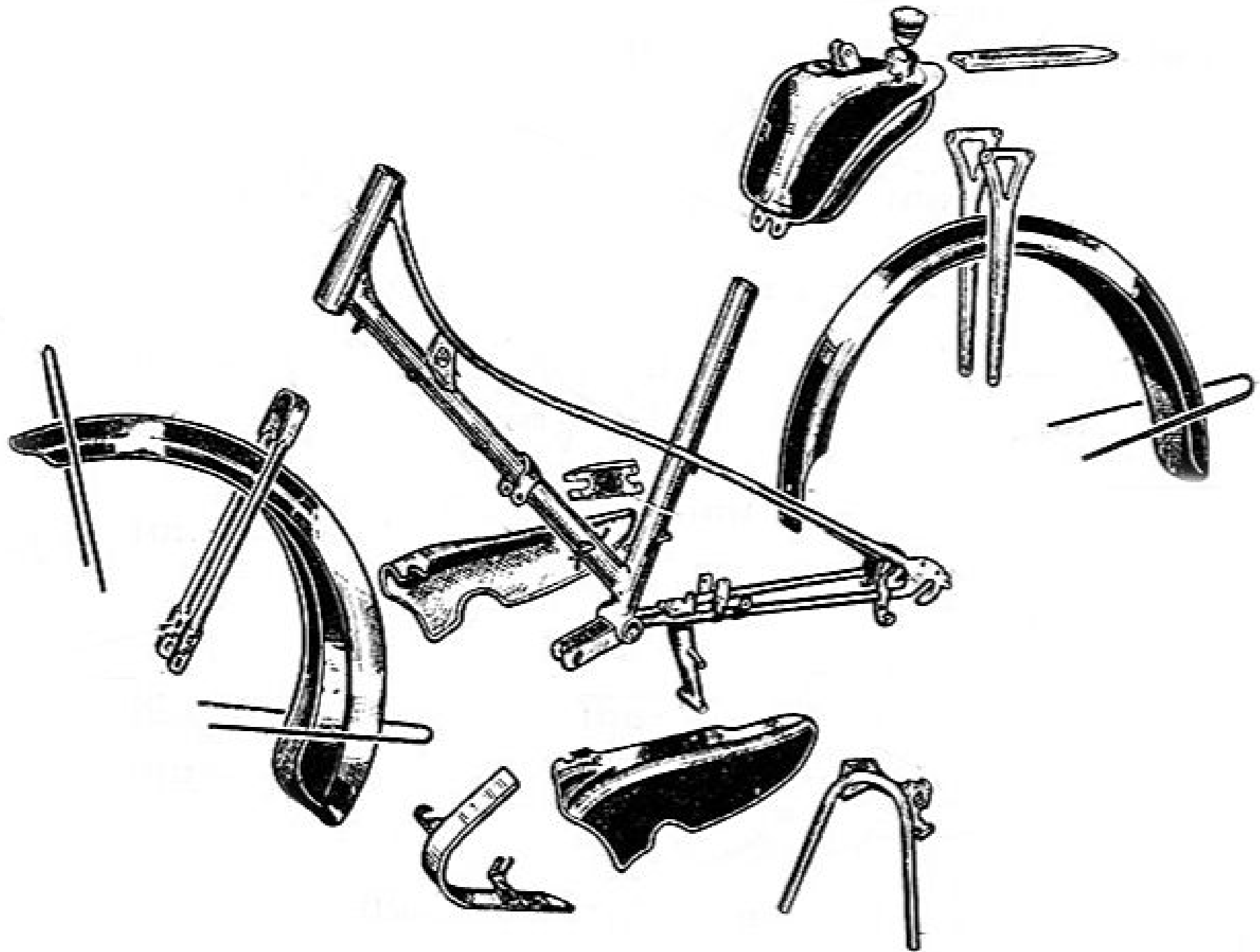

# MOBYLETTE Type A.V. 36 ou A.U. 36

le cadre est identique au type AV37 sauf certains accessoires

Moyeu complet avec pignon arrière 56 ds 14645

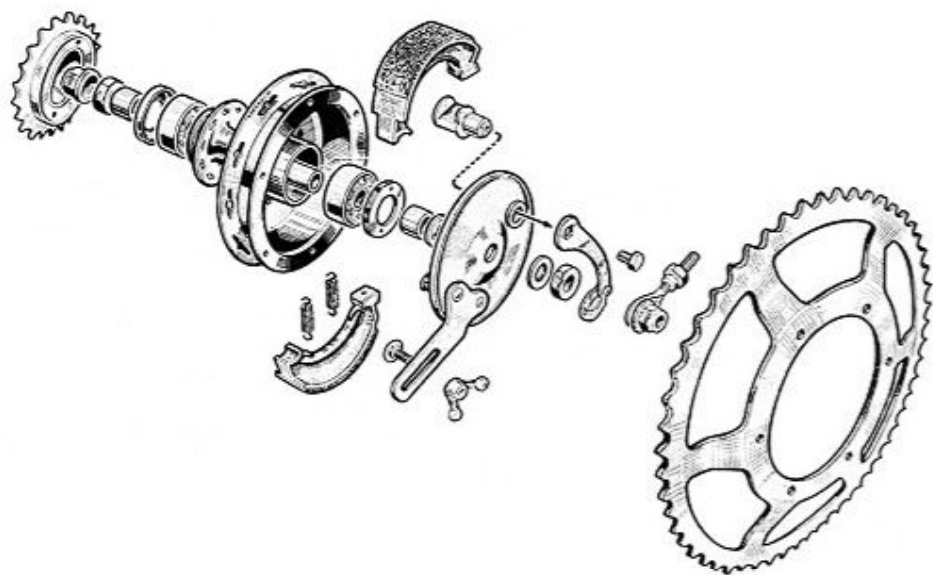

ROUE ET MOYEU ARRIÈRE "IDÉAL"

Moyeu avant complet 14618

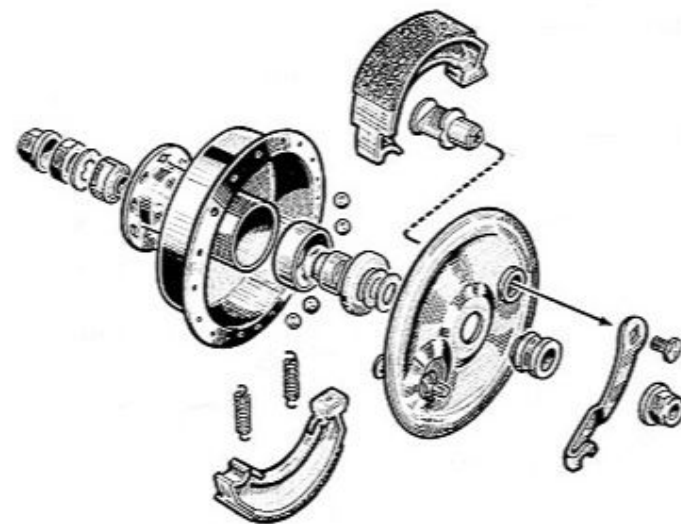

ROUE ET MOYEU AVANT "IDÉAL"

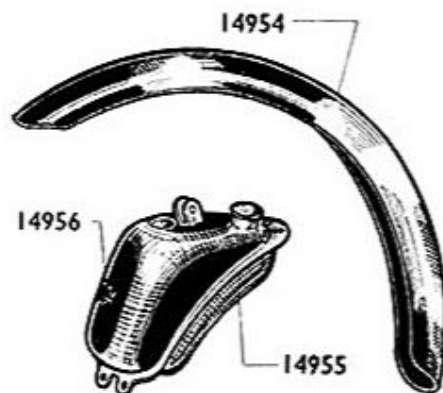



# AV37 ou AU37

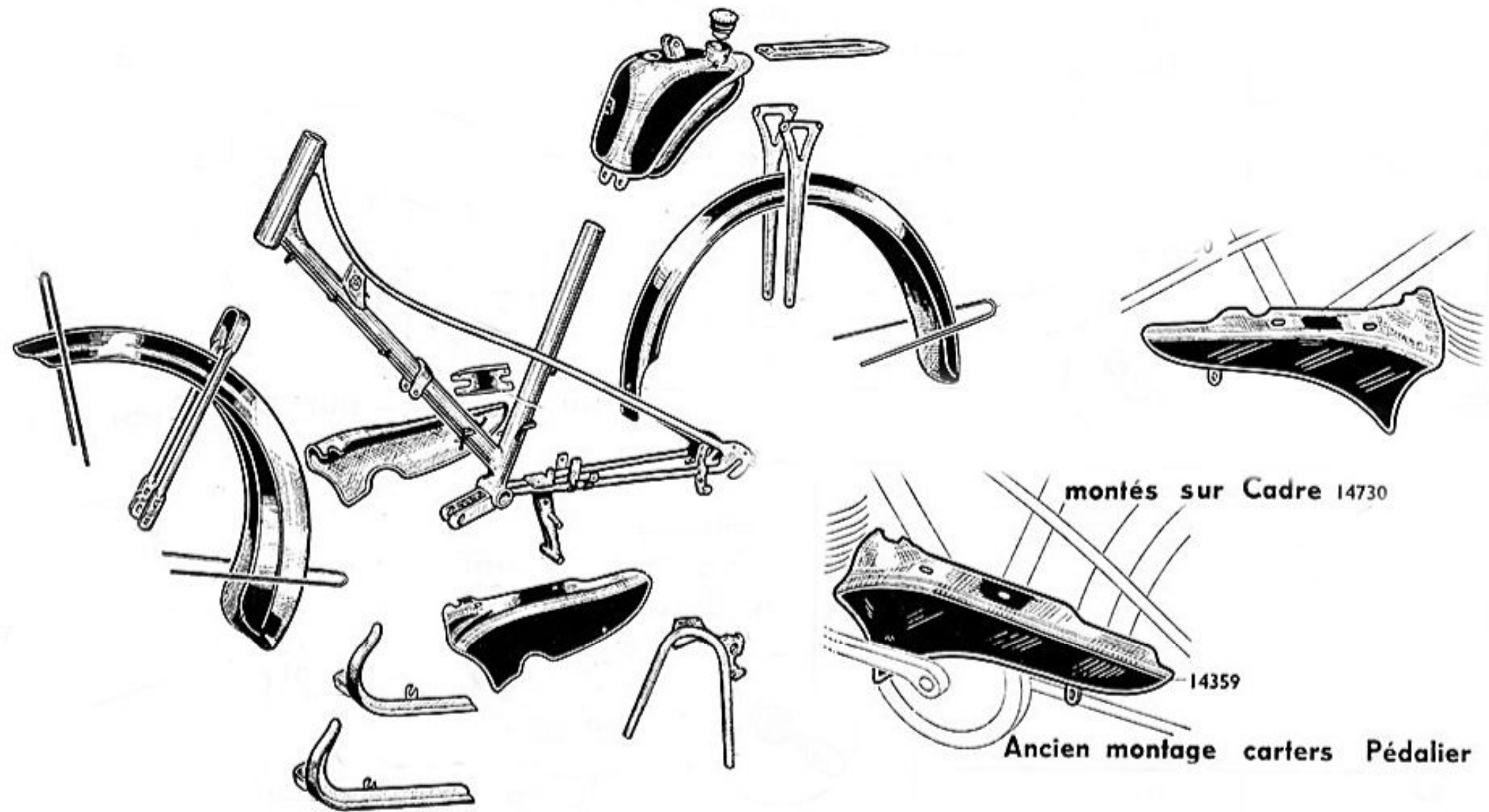

**AV 37**

**AU 37**

Remplacé par 15302

**NOTA 2.**

Boite de pédalier à bagues  
Sans hauban arrière  
Patte pour frein tambour arrière  
Trou pour tendeur variateur

Teinte mastic **N° 14730**

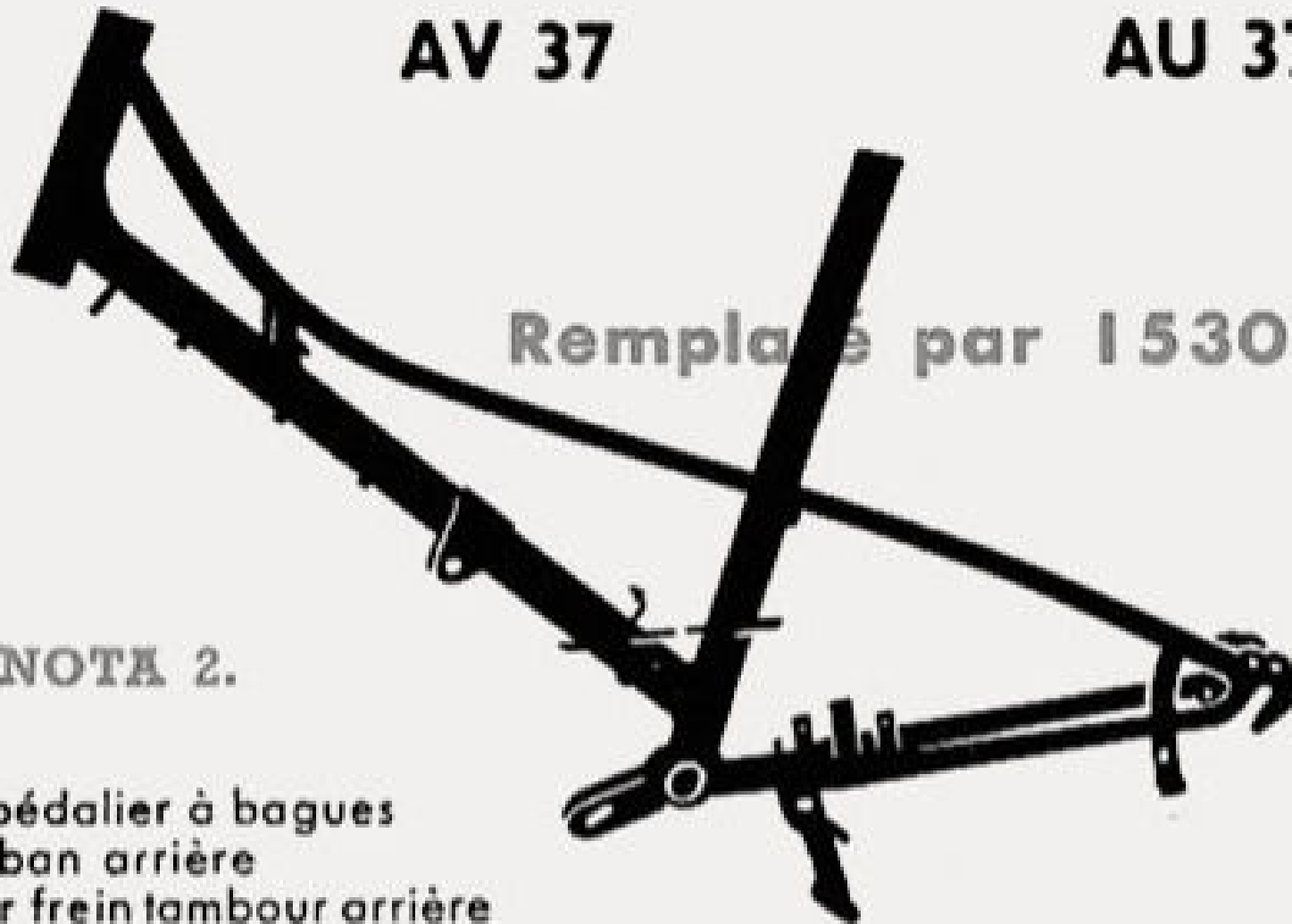

**AV 37**

**AU 37**

**Remplacé par 15302**

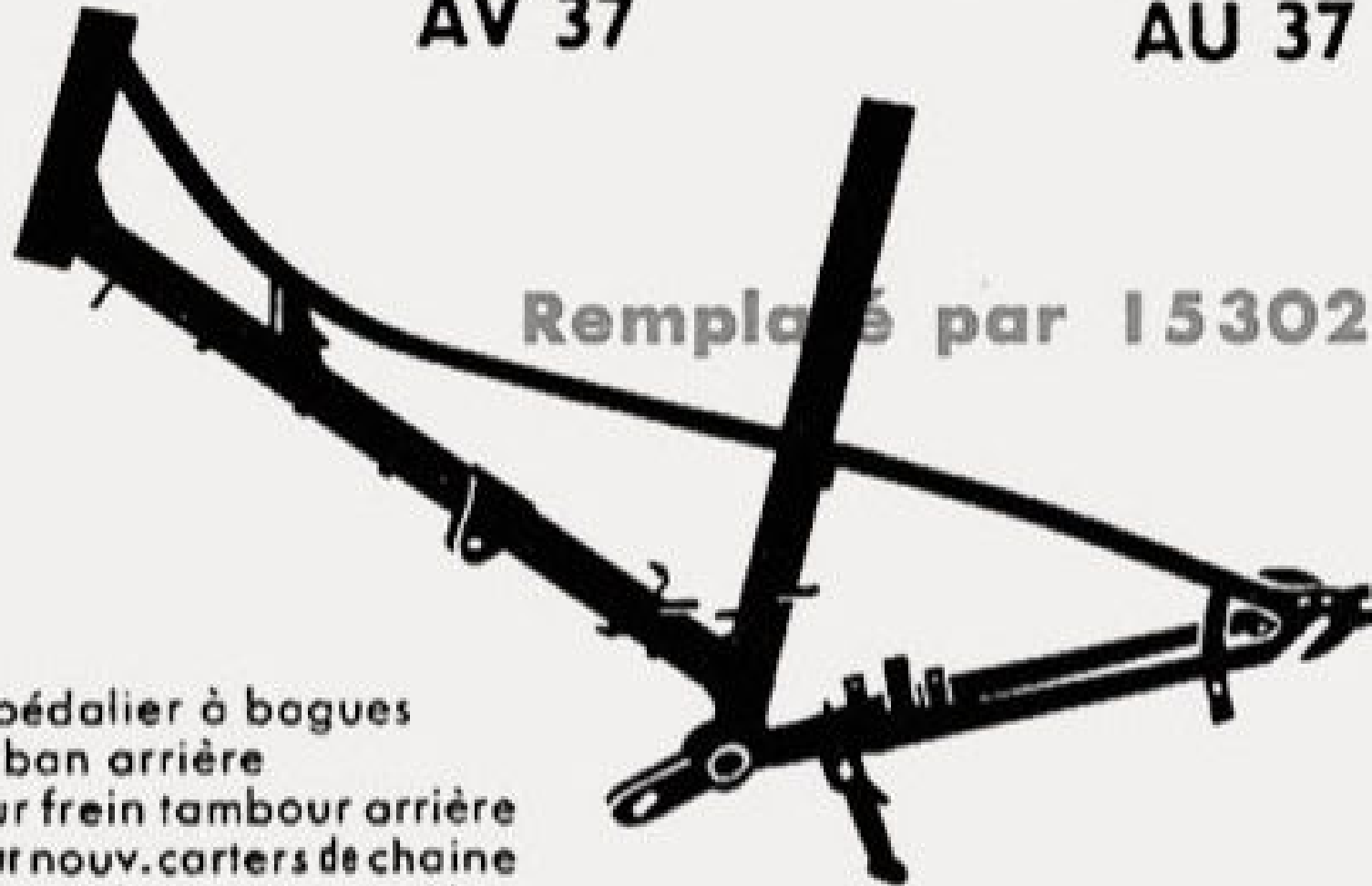

Boîte de pédalier à bogues  
Sans hauban arrière  
Patte pour frein tambour arrière  
Pattes pour nouv. carters de chaîne  
Pattes pour réglage roue arrière  
Trou pour tendeur variateur

Teinte mastic **N° 15086**

**AV 37**  
**AV 36**

**AU 37**  
**AU 36**

Remplac par 15302



Boite de pédalier à bagues  
Sans hauban arrière  
Patte pour frein tambour arrière  
Pattes pour nouv. carters de chaîne  
Trou pour tendeur variateur

Teinte mastic **N° 15118**

# MOBYLETTE

Type AV 42 ou AU 42

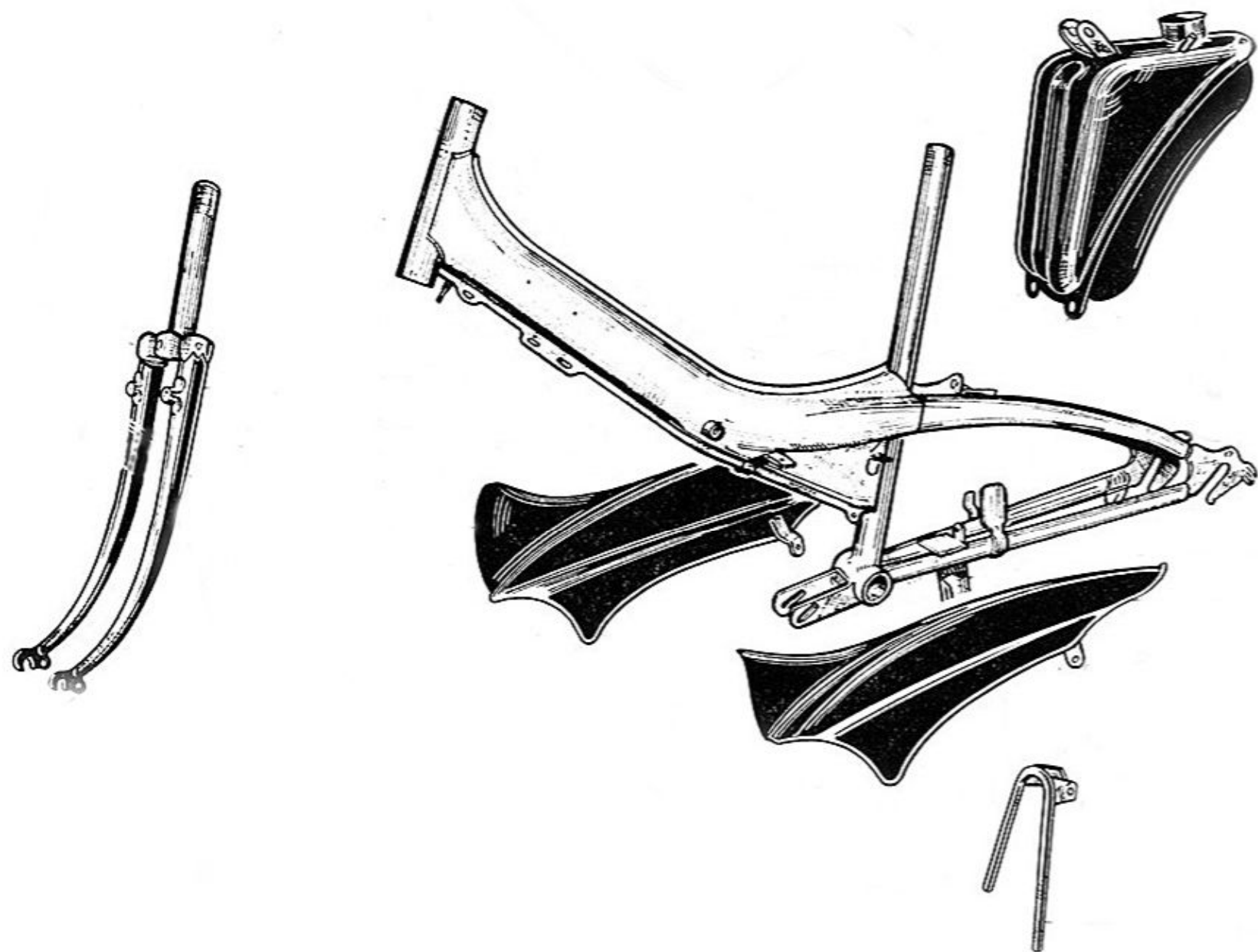

MOBYLETTE AV42a Bonnie



**MOBYLETTE**

**Type AV 43 ou AU 43**

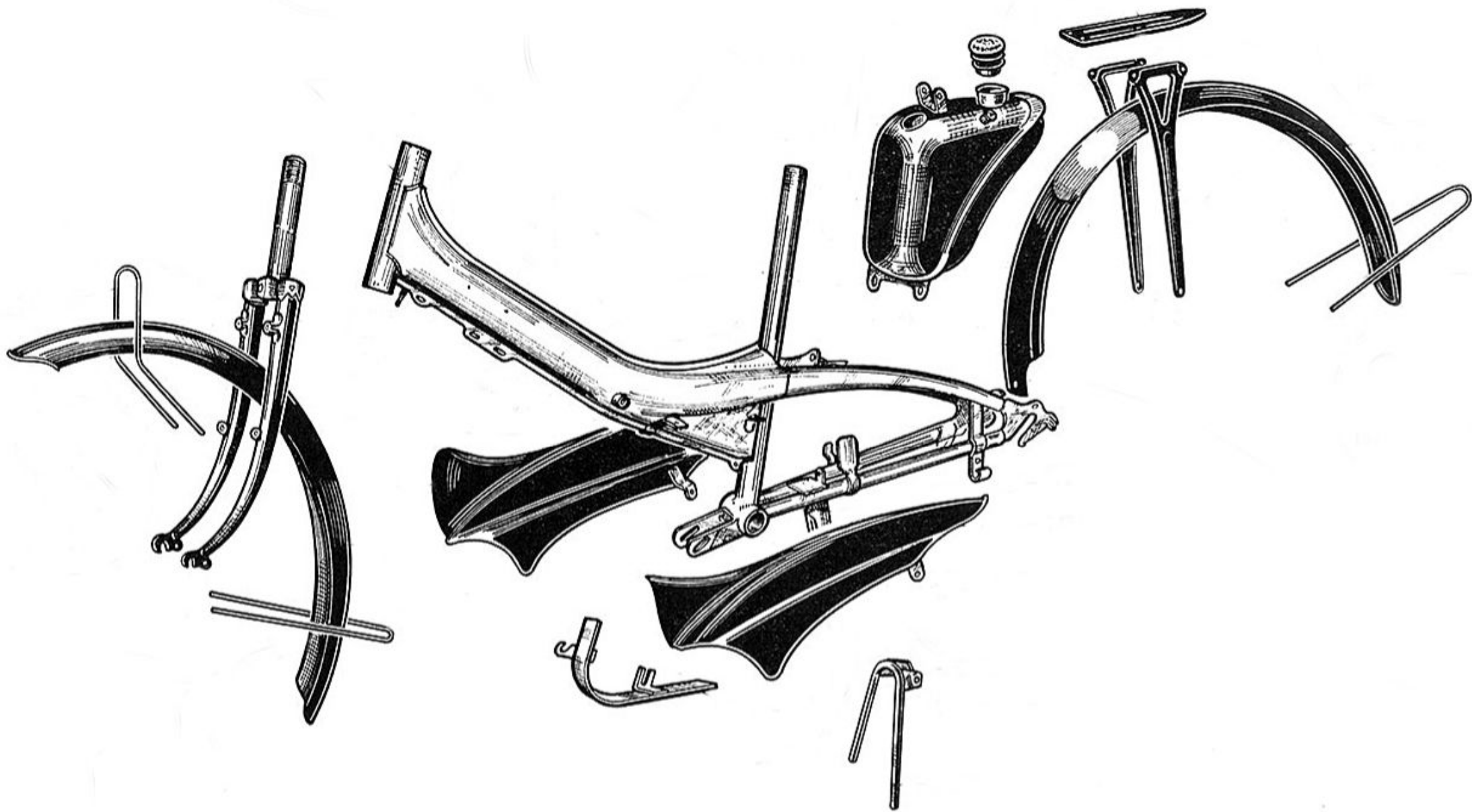

AV 43

AU 43

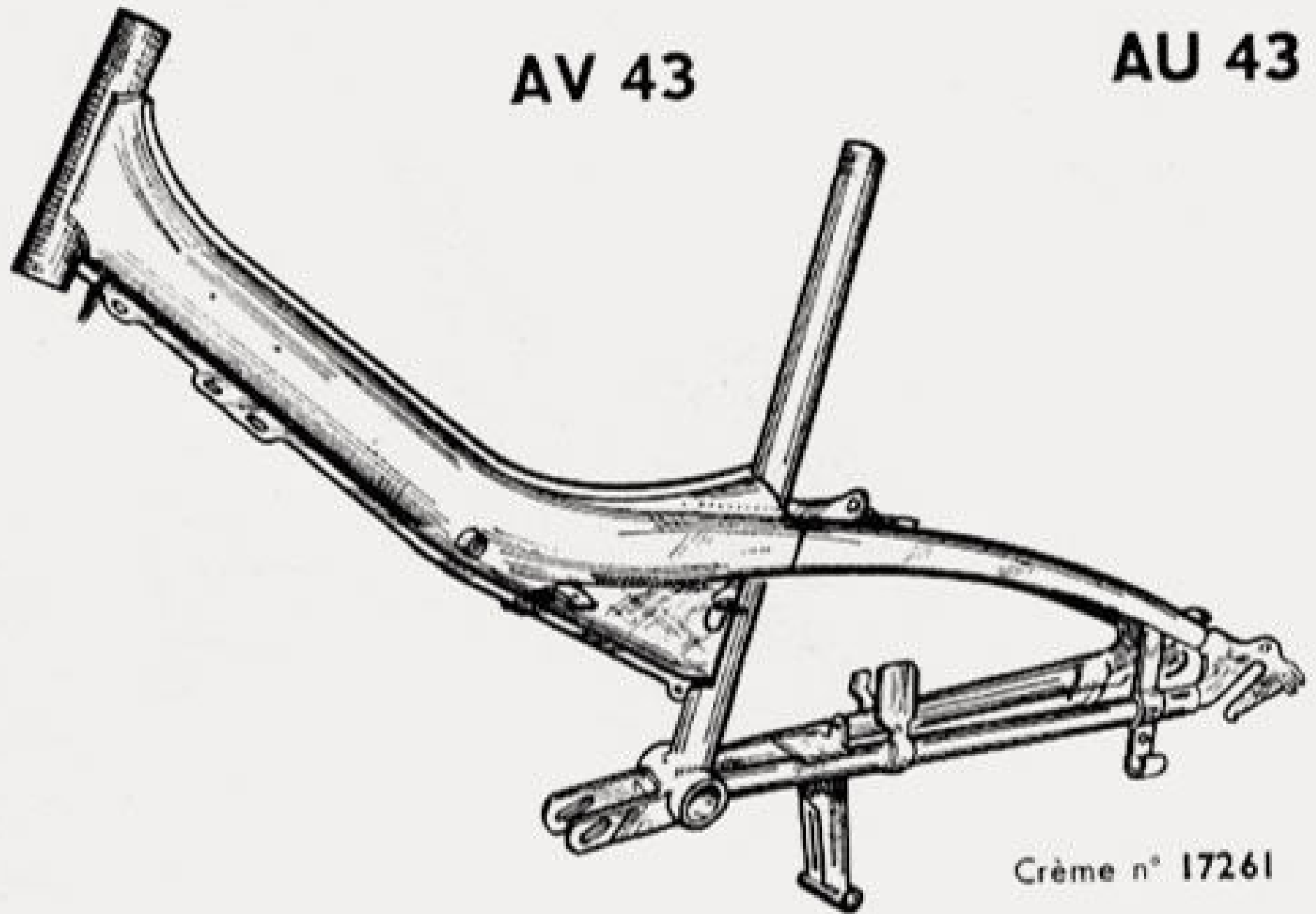

Crème n° 17261



# MOBYLETTE

Type AV 44 ou AU 44

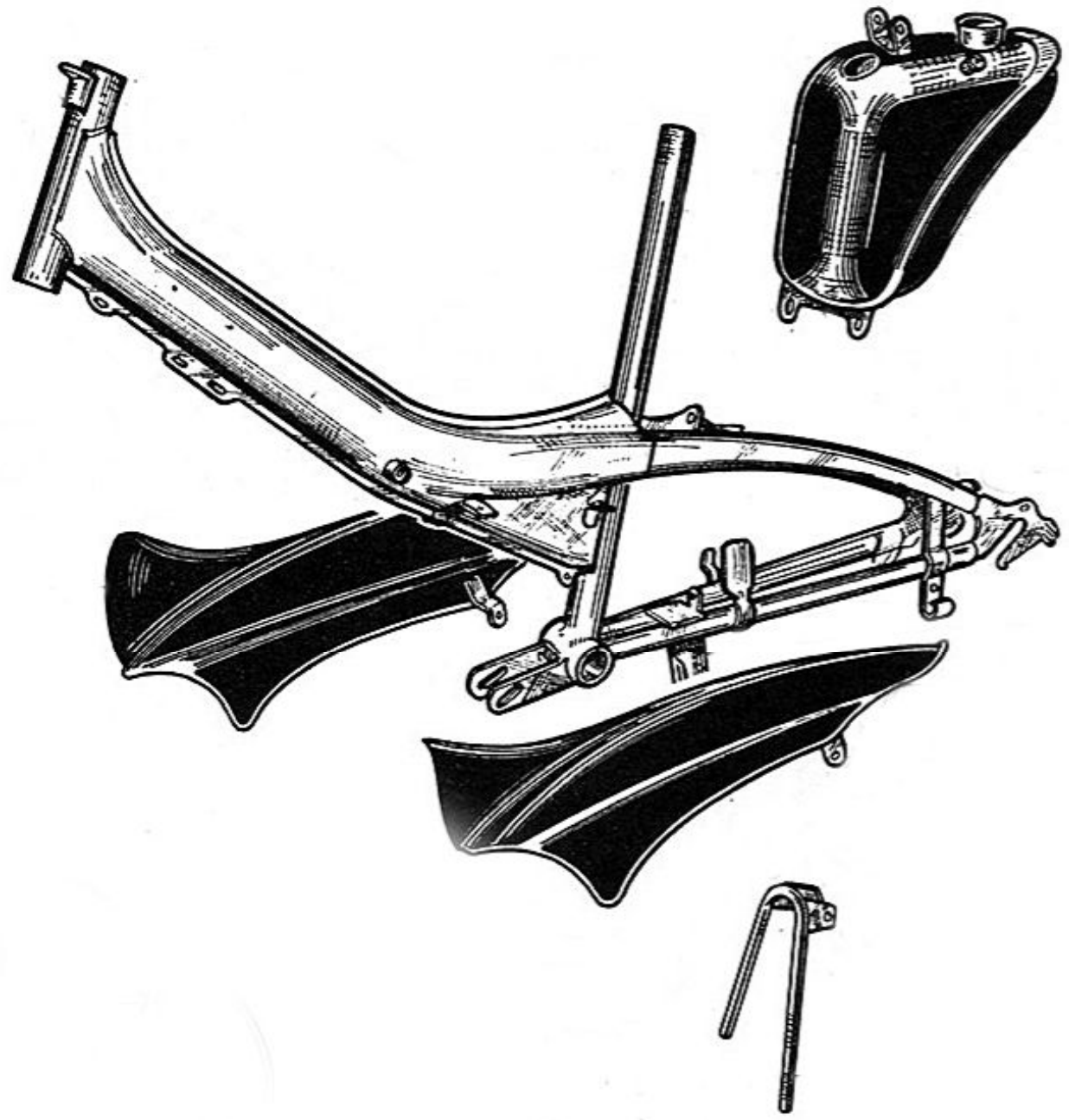

**AV 44**

**AU 44**

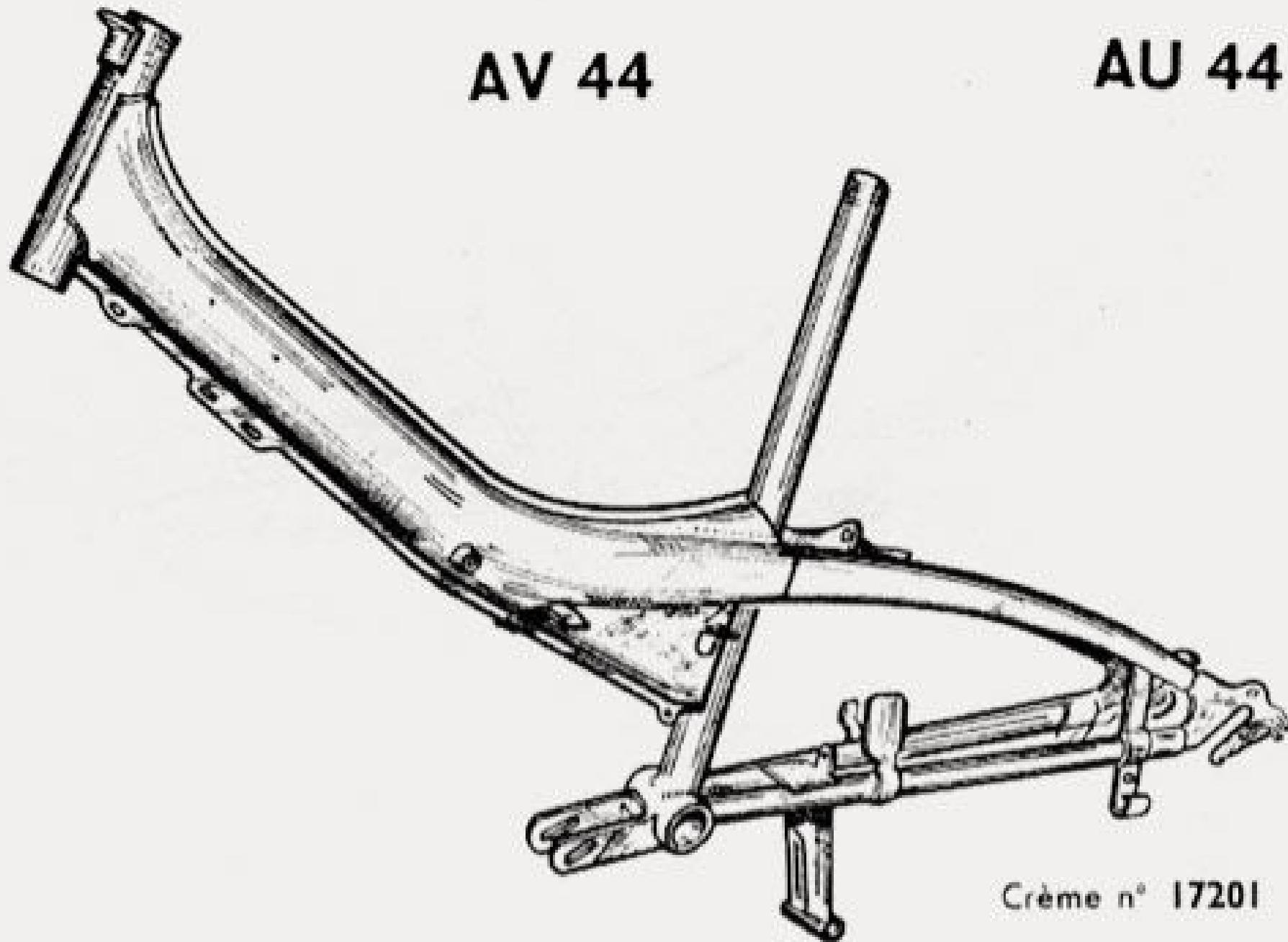

Crème n° 17201

**MOBYLETTE**

**Types AV ou AU 49 - 46**



# MOBYLETTE type AV47

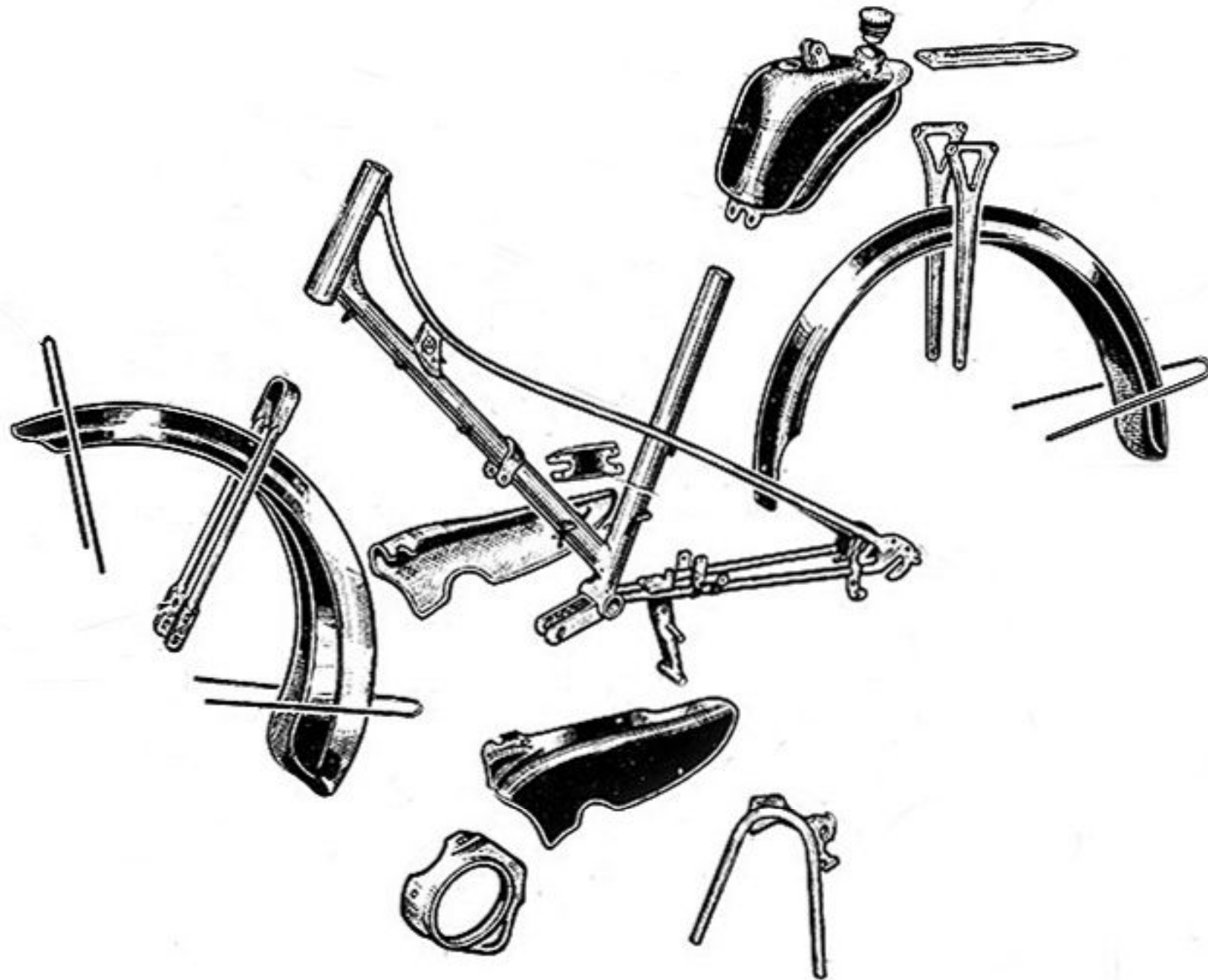

# MOBYLETTE

Type AV 48 ou AU 48

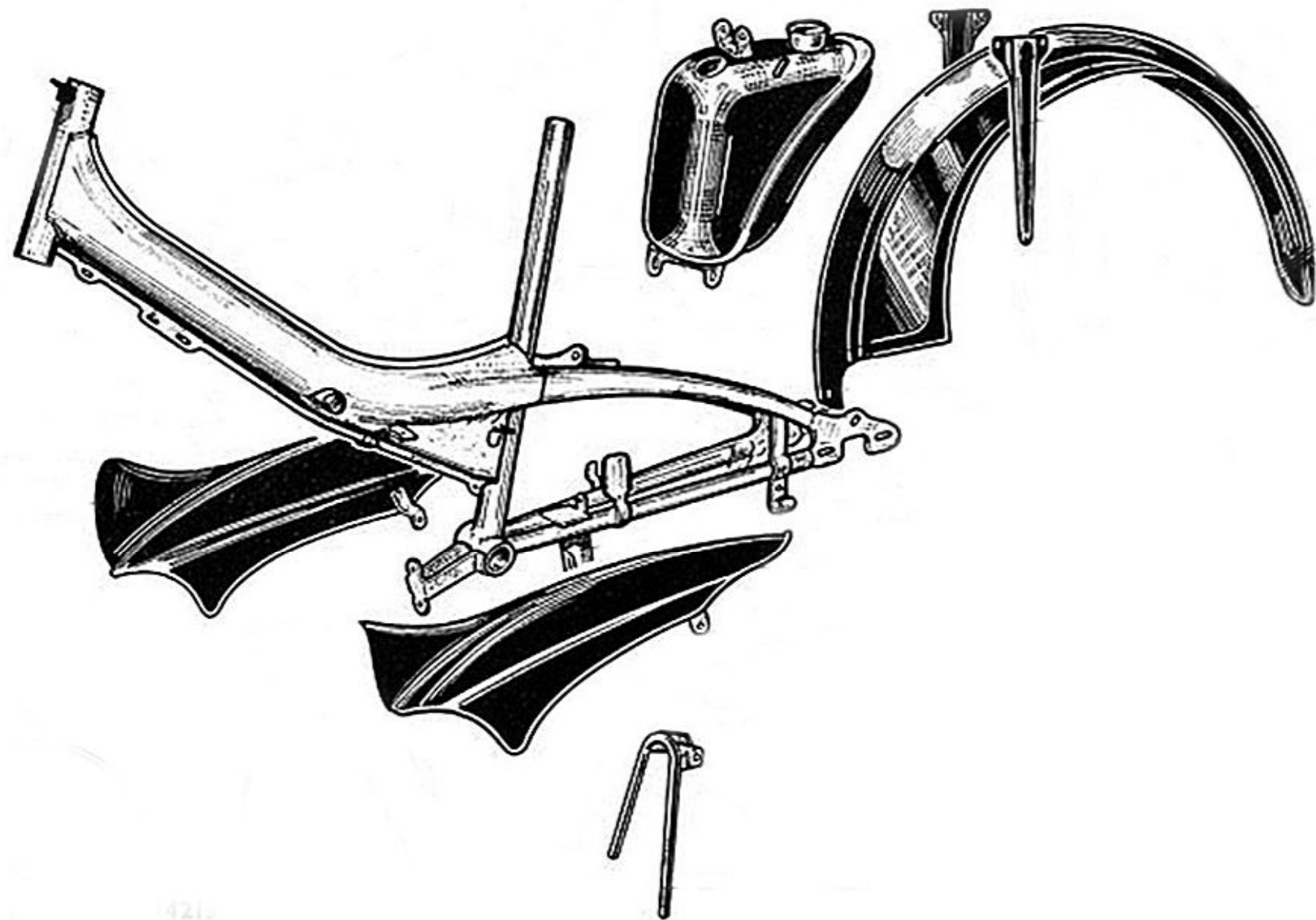

**AV 50 Spéciale AU 50**



Chaudron n° 17301

# MOBYLETTE Type AV 51 ou AU 51

Reservoir nouveau modèle

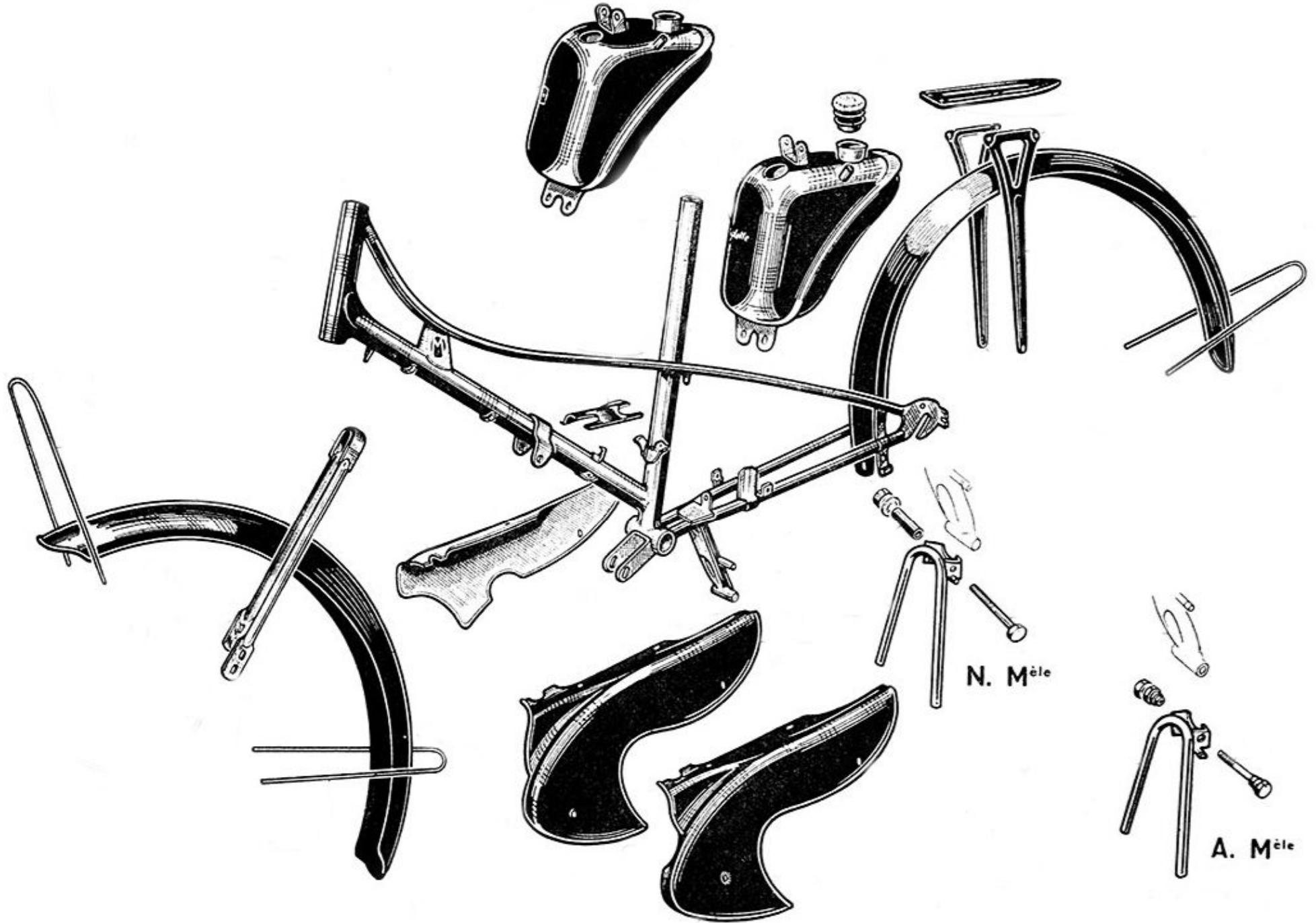

# MOBYLETTE Type AV 54 ou AU 54

Reservoir nouveau modèle 14789

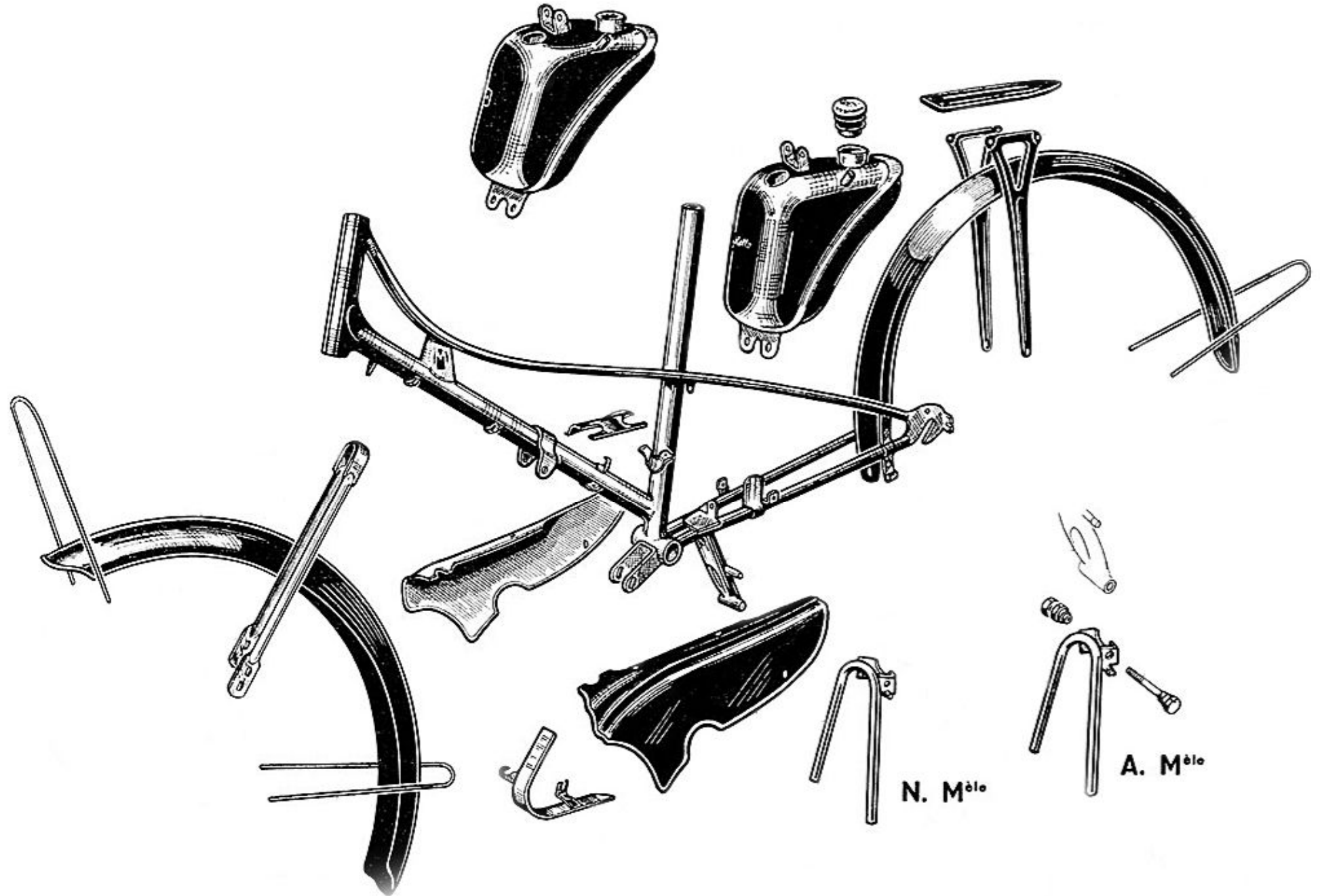



# MOBYLETTE

Types AV ou AU 59 - 56



MOBYLETTE AV65    avant 1966

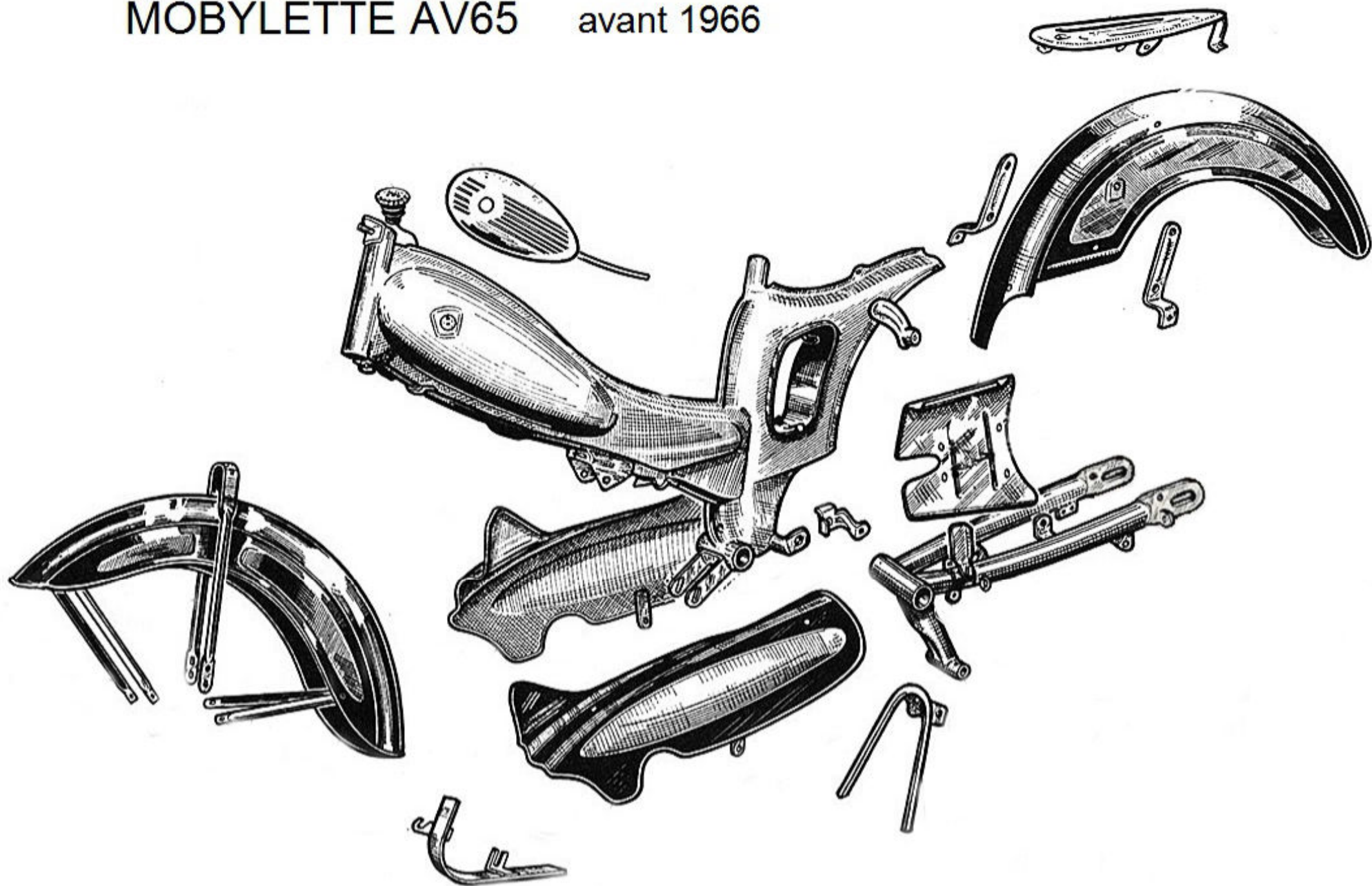

MOBYLETTE AV65

apres 1966

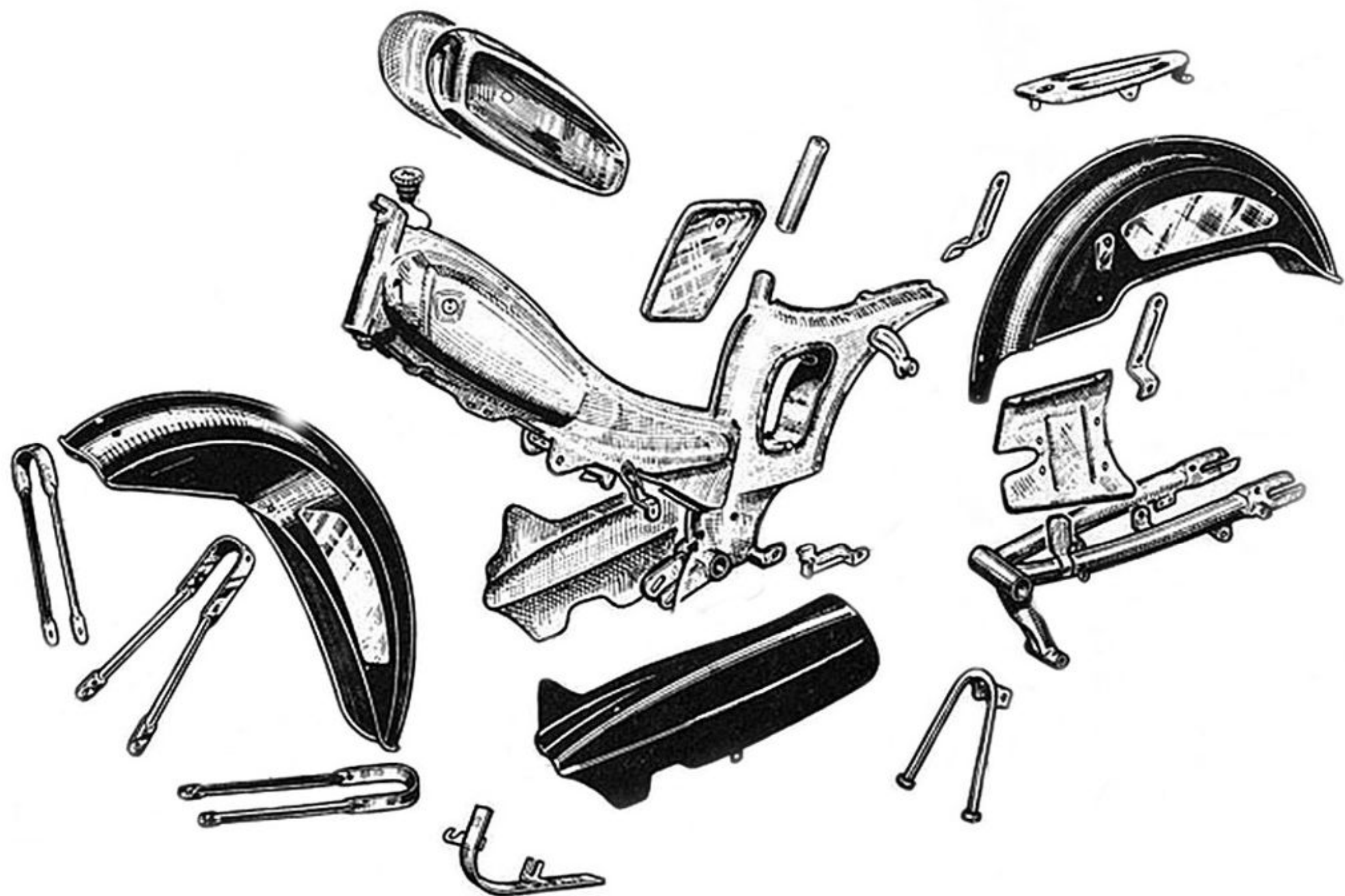

# MOBYLETTE AV68

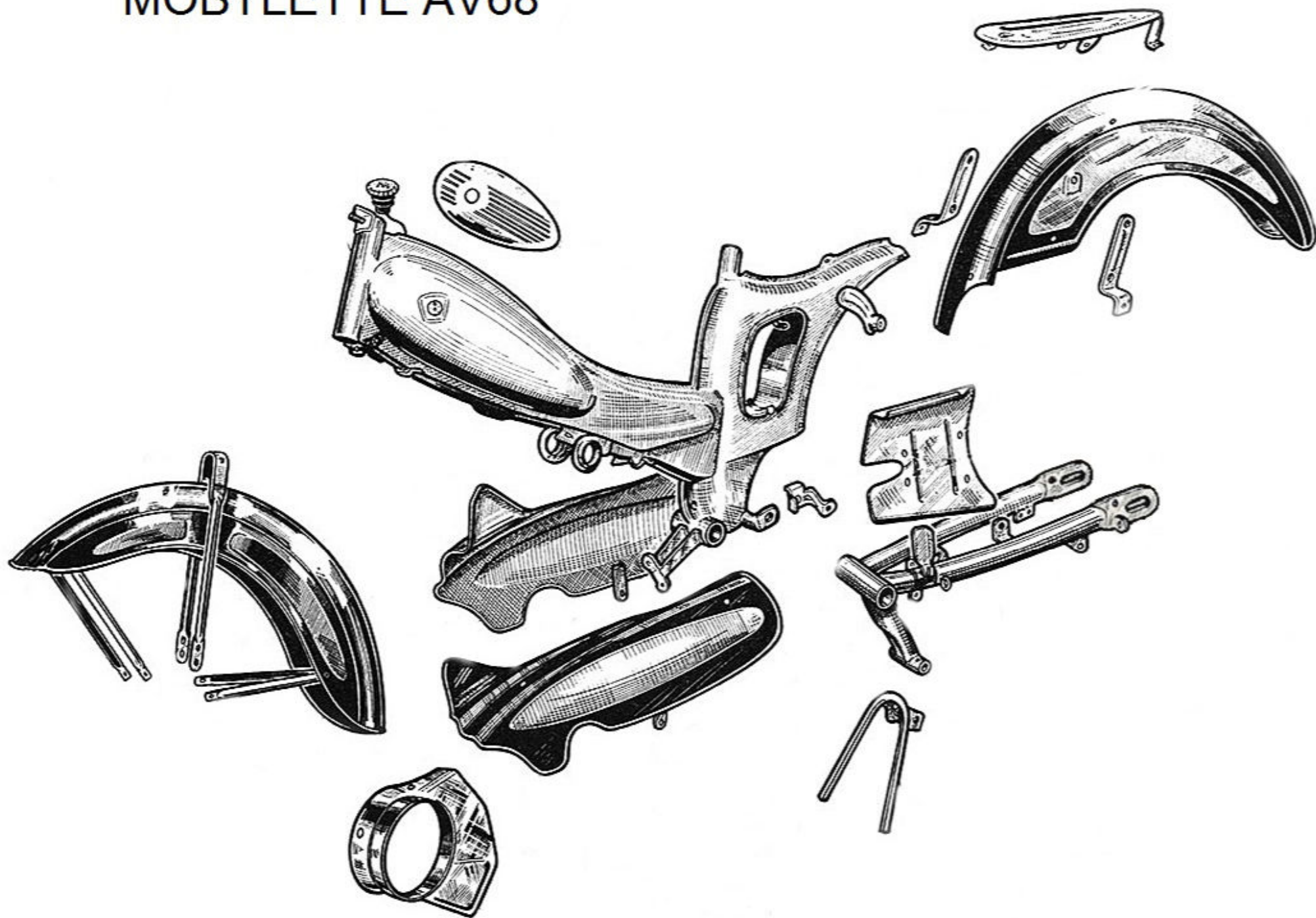

# MOBYLETTE AV75

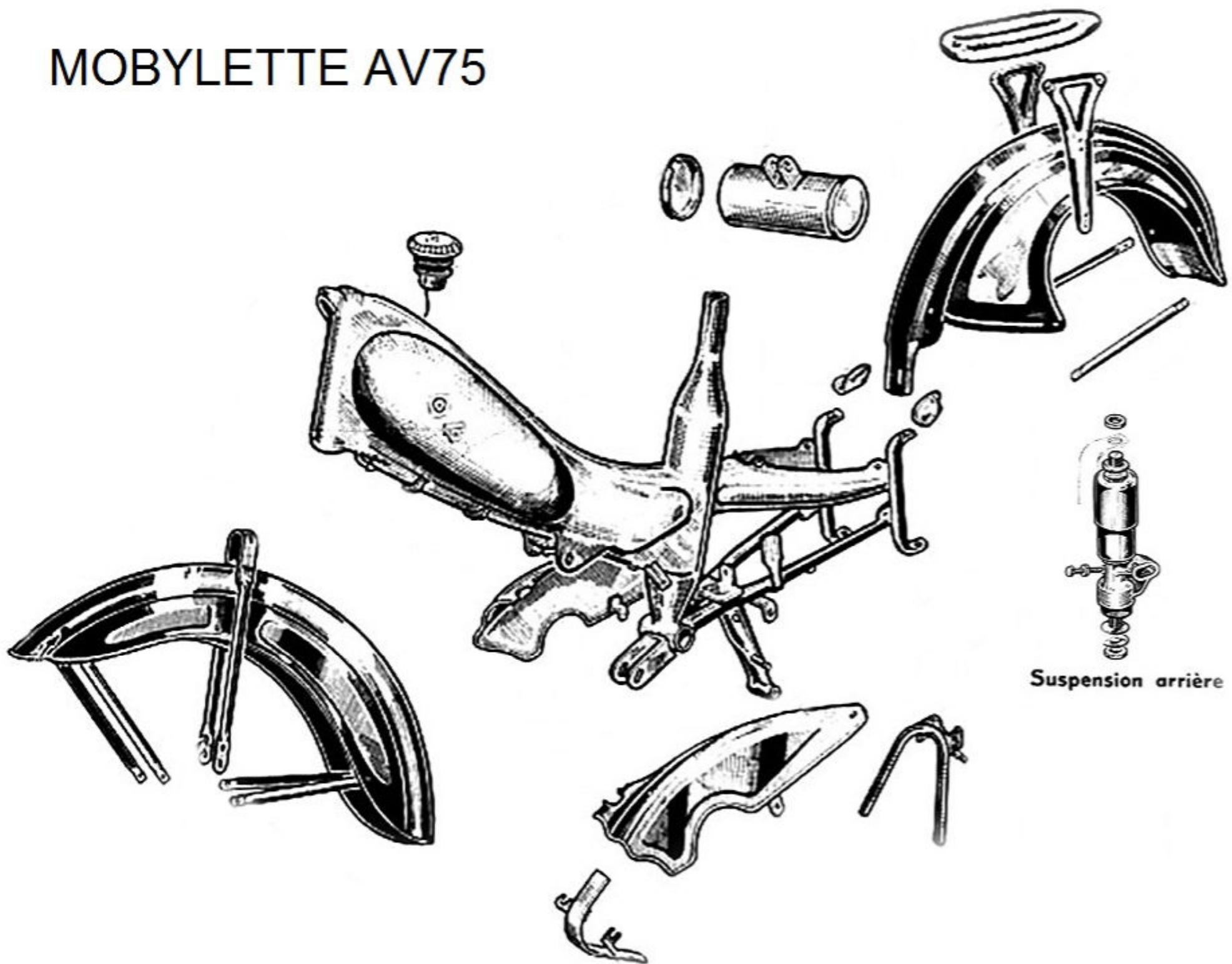

Suspension arriere

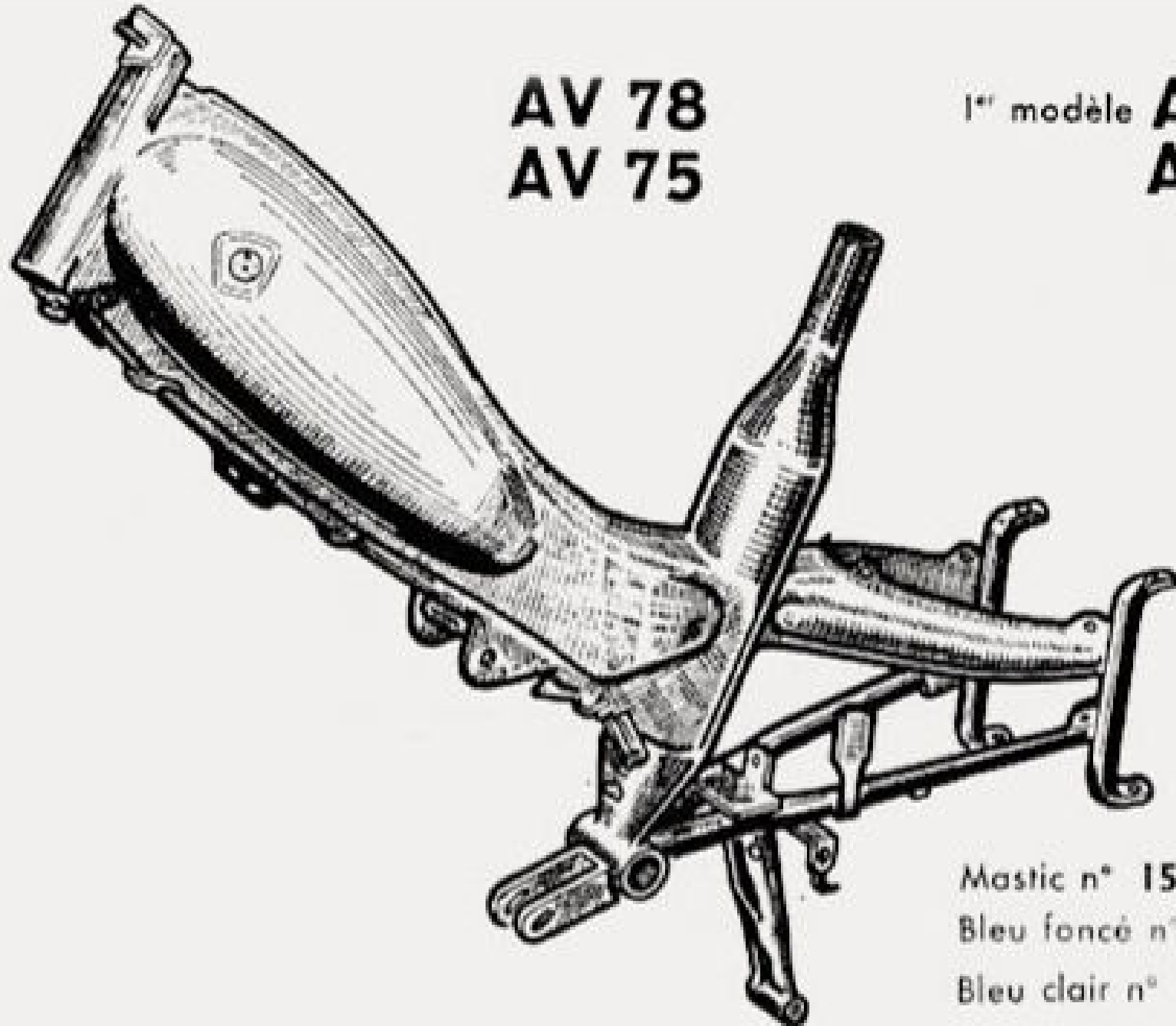

**AV 78**  
**AV 75**

1<sup>er</sup> modèle **AU 78**  
**AU 75**

Mastic n° 15601  
Bleu foncé n° 15650  
Bleu clair n° 15400

# MOBYLETTE

## Type AV 76 ou AU 76

avant 1964

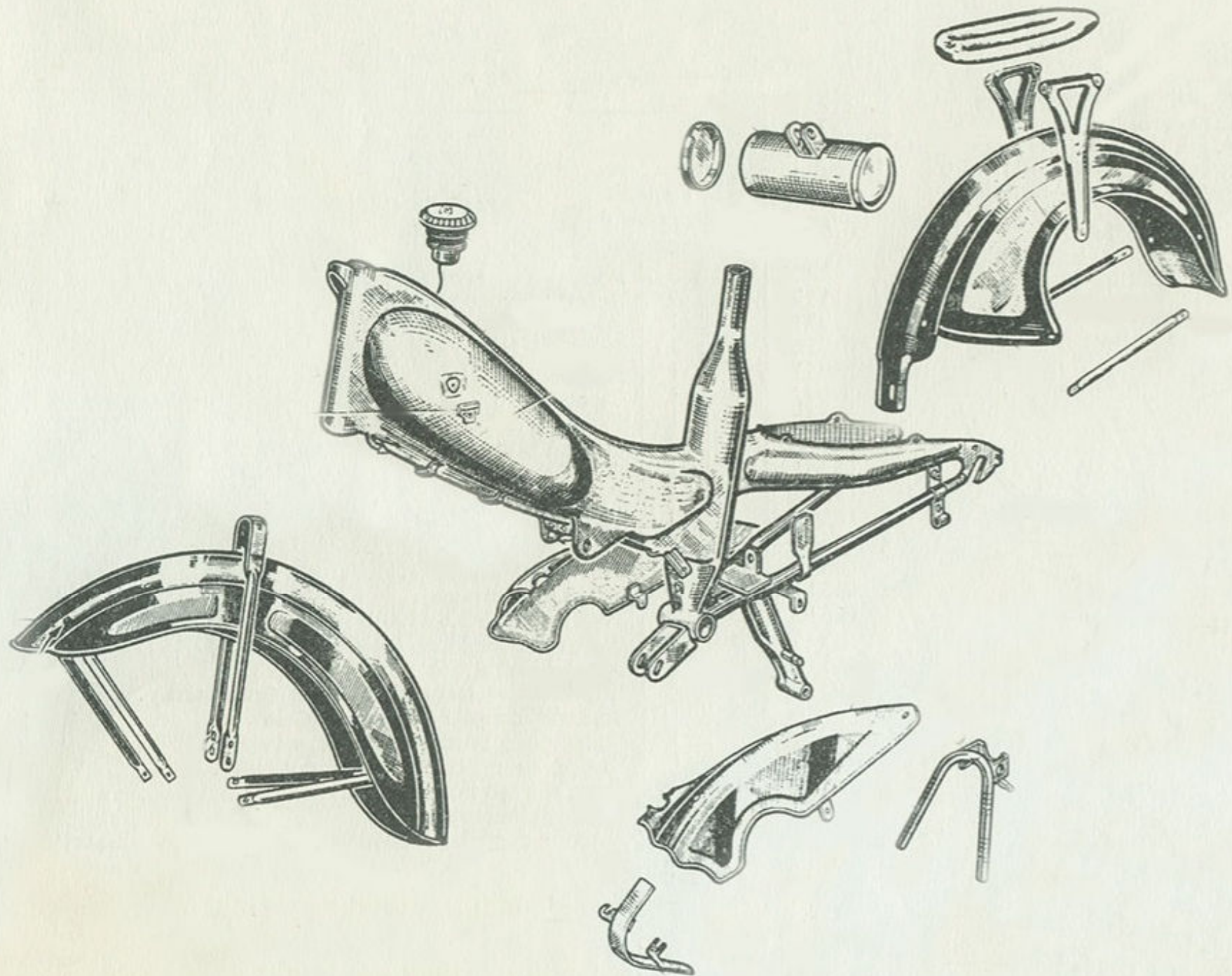

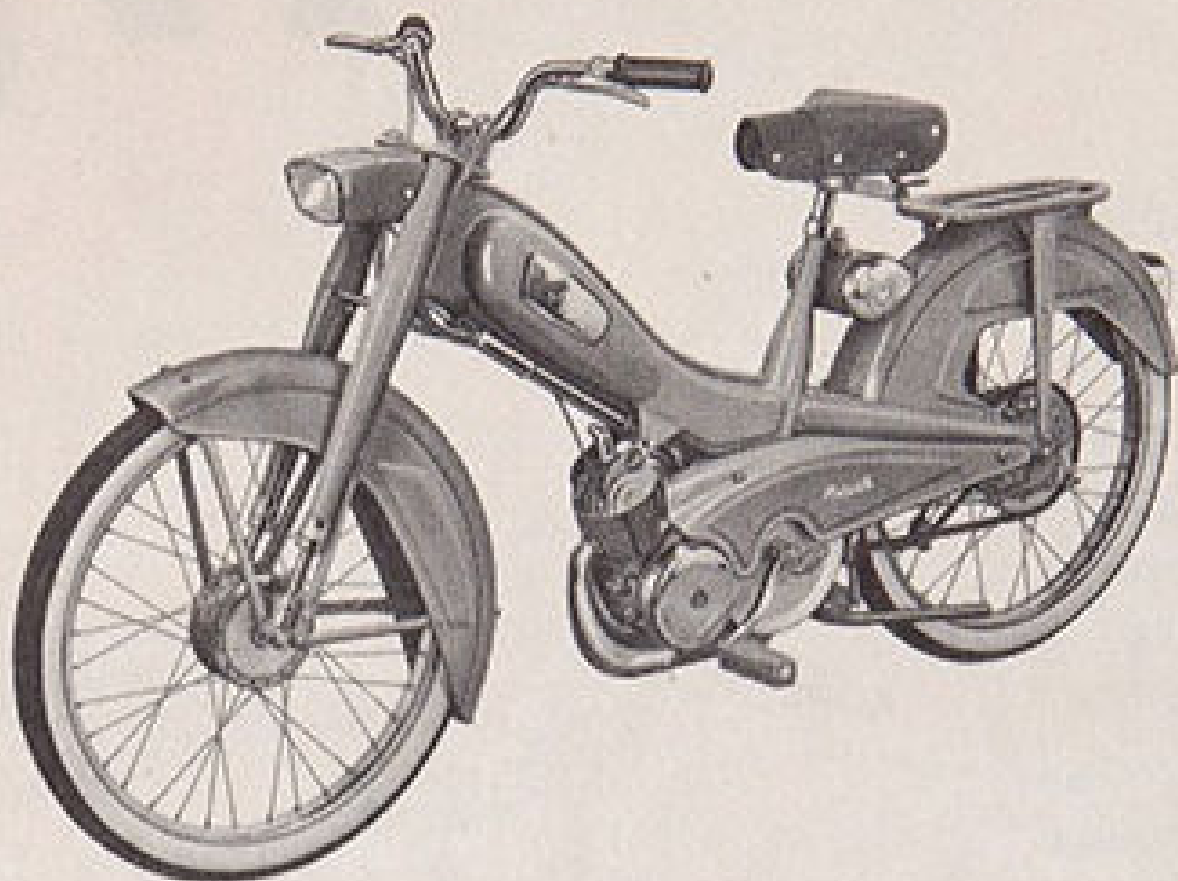

## catalogue 1964

**MOBYLETTE "MONOSTANDARD" TYPE AV 76.** Moteur à double embrayage automatique "**DIMOBY**" - châssis-coque formant réservoir (5 L.) - fourche télescopique - selle Confort - pneumatiques de 23 x 2 à flancs blancs - freins AV et AR monoblocs - garde-boue profonds avec flasques de protection - timbre avertisseur.

Prix : **616,50** Frs T.L. comprise.



# Pièces "A.V. 77" différentes du type "A.V. 78"

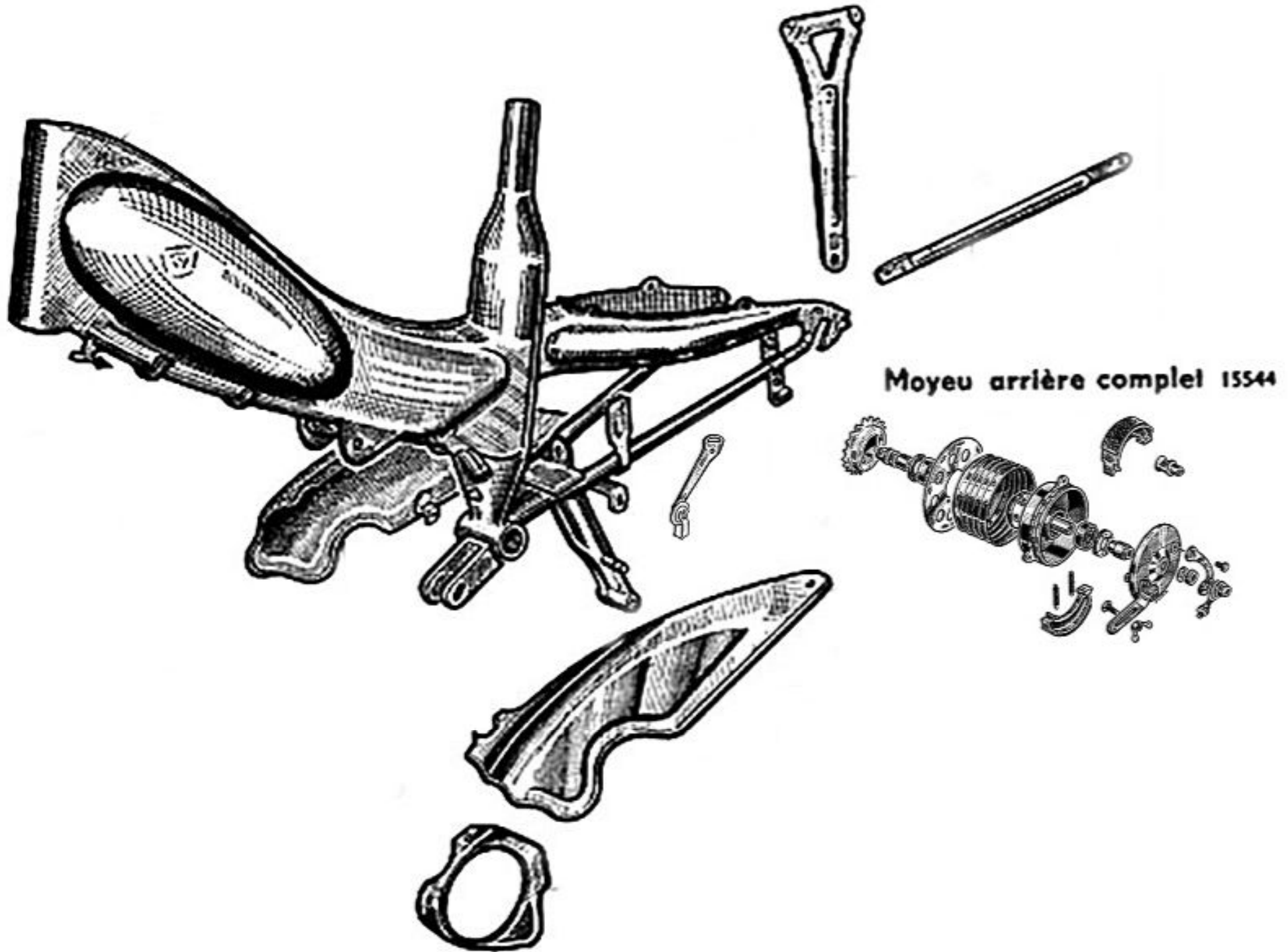

# MOBYLETTE AV78

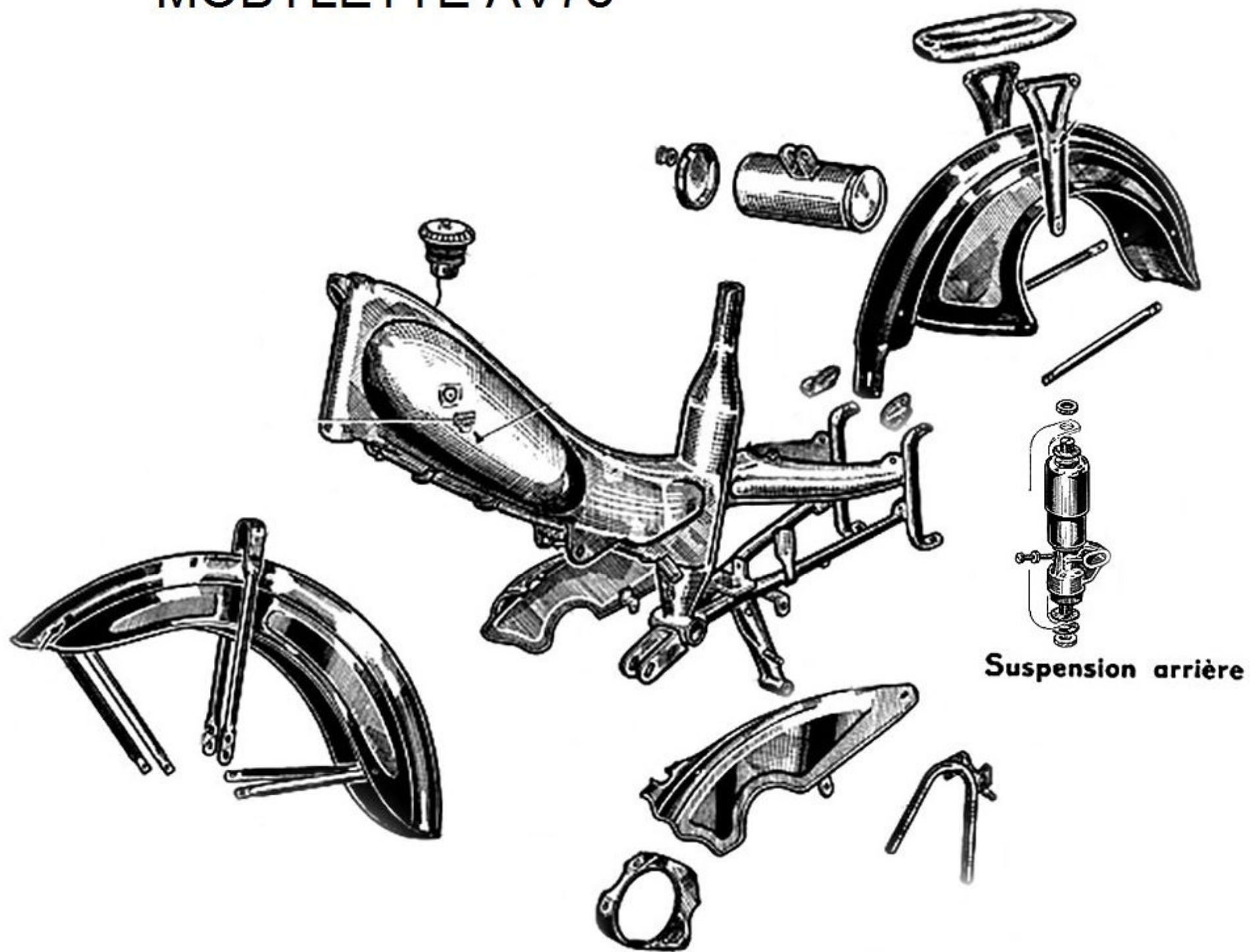

**AV 78**

2<sup>e</sup> modèle **AU 78**

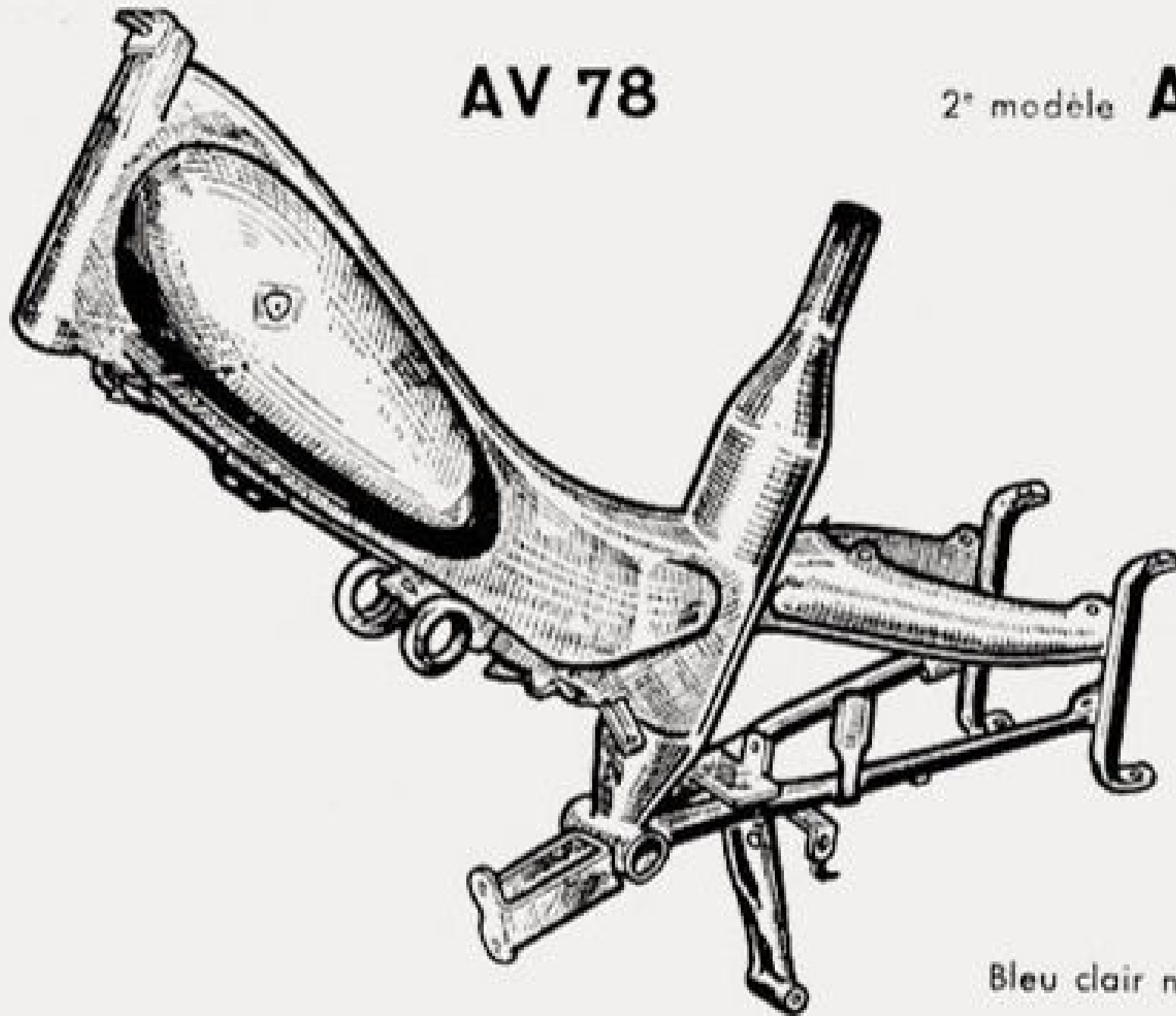

Bleu clair n° 16504

# MOBYLETTE

Type AV 79 ou AU 79

avant 1964

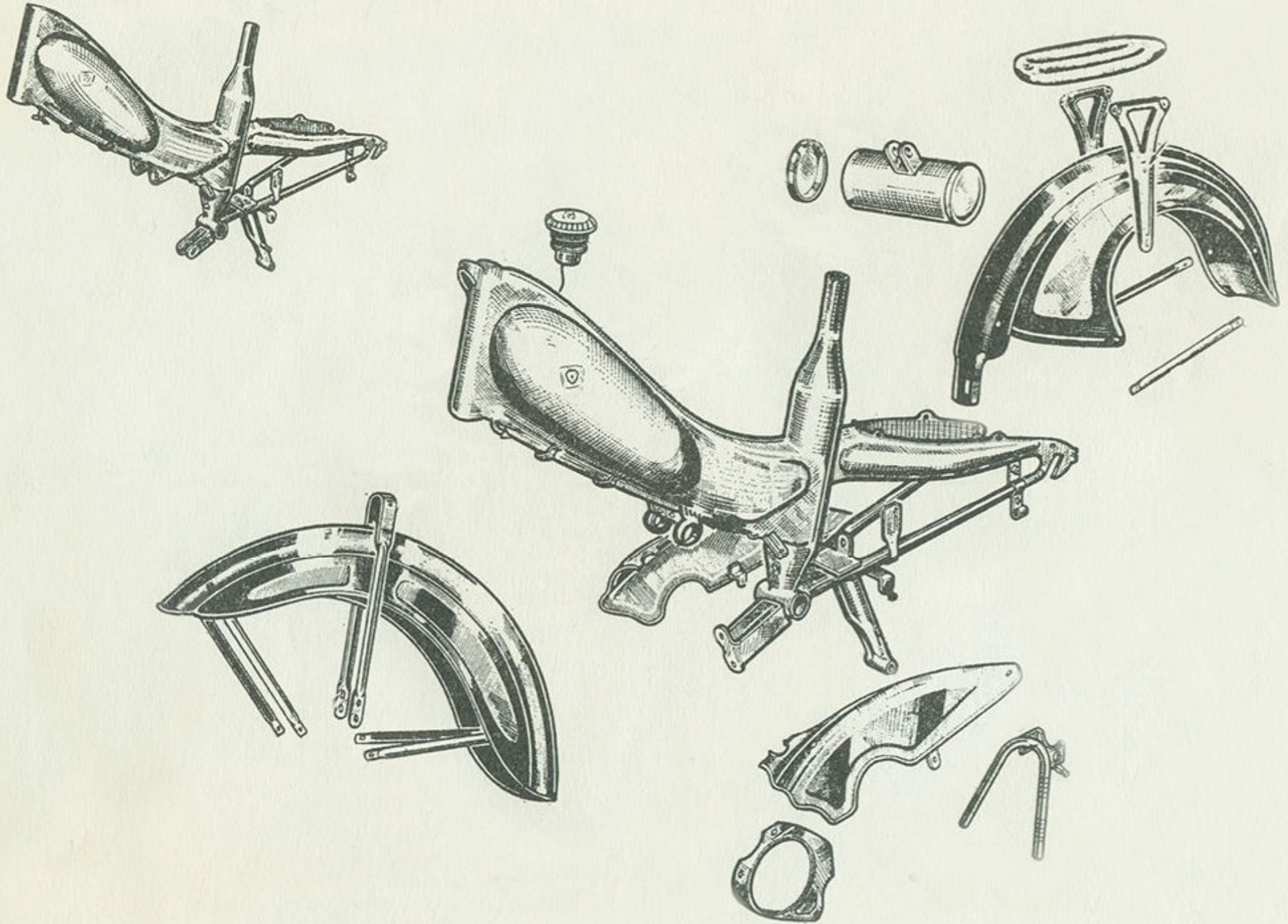

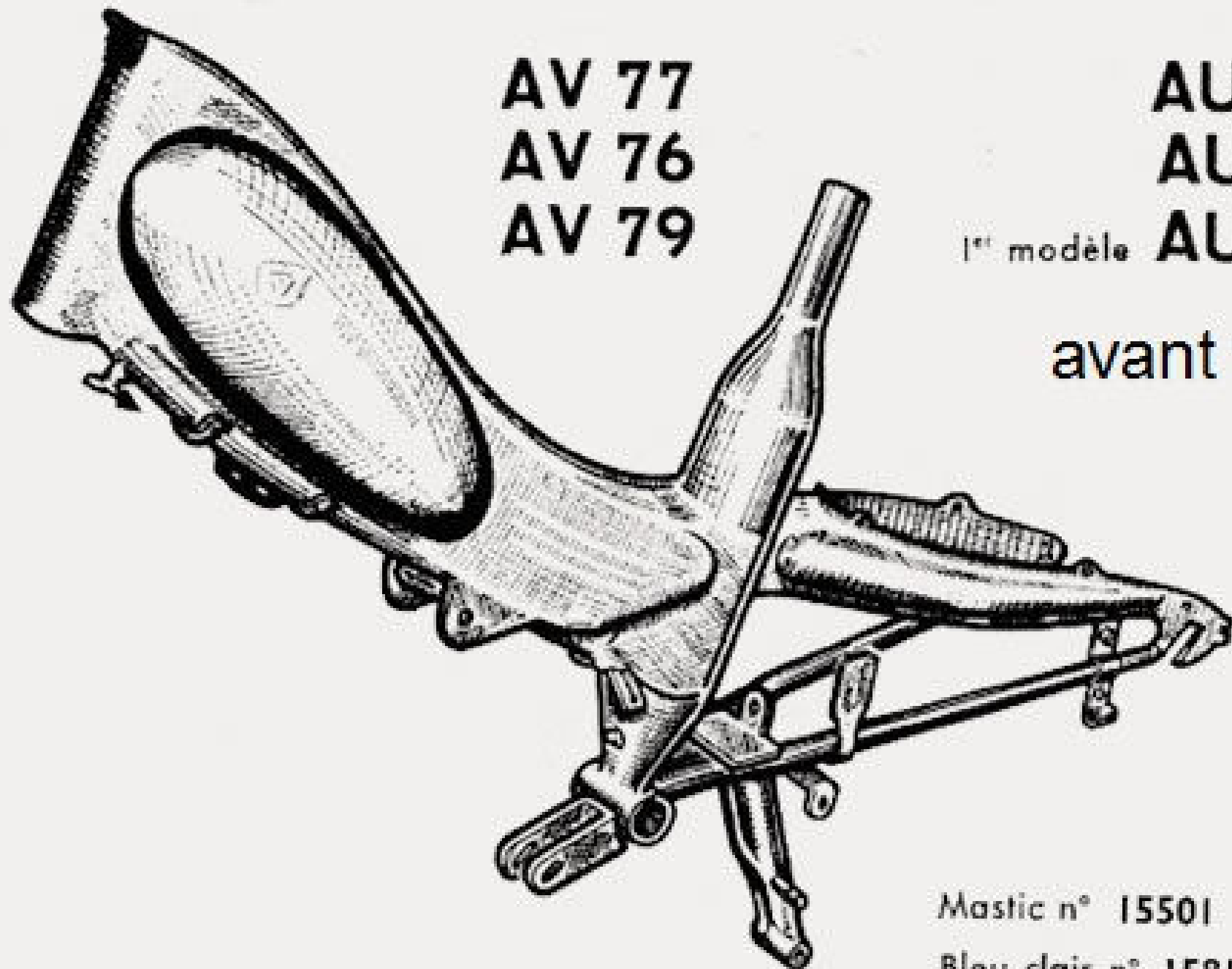

**AV 77**  
**AV 76**  
**AV 79**

**AU 77**  
**AU 76**  
**1<sup>er</sup> modèle AU 79**

**avant 1964**

Mastic n° 15501  
Bleu clair n° 15810



## catalogue 1964

**MOBYLETTE "MOBYMATIC-SUPER"**  
**TYPE AV 79.** Moteur à double  
embrayage automatique "**DIMOBY**"  
et **changement de vitesse**  
**automatique "MOBYMATIC"**  
châssis coque formant réservoir (5 L.) -  
fourche télescopique - selle Confort -  
pneumatiques de 23 x 2 à flancs  
blancs - freins AV et AR monoblocs -  
garde-boue profonds avec flasques de  
protection - timbre avertisseur.

Prix : **666** Frs T.L. comprise.

# MOBYLETTE

Type AV 85 ou AU 85 avant 1964

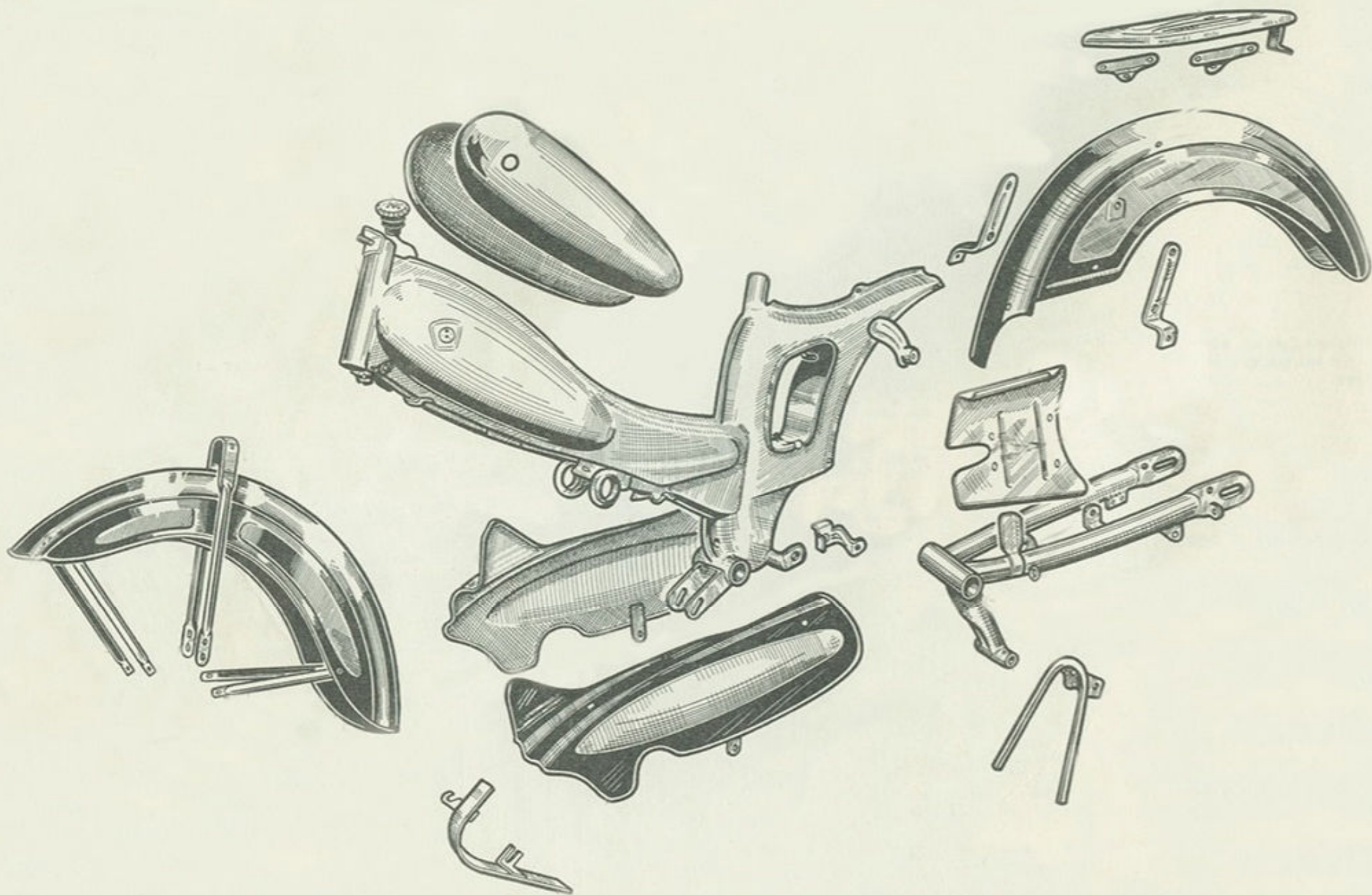

**AV 85**

**AU 85**

**avant 1964**

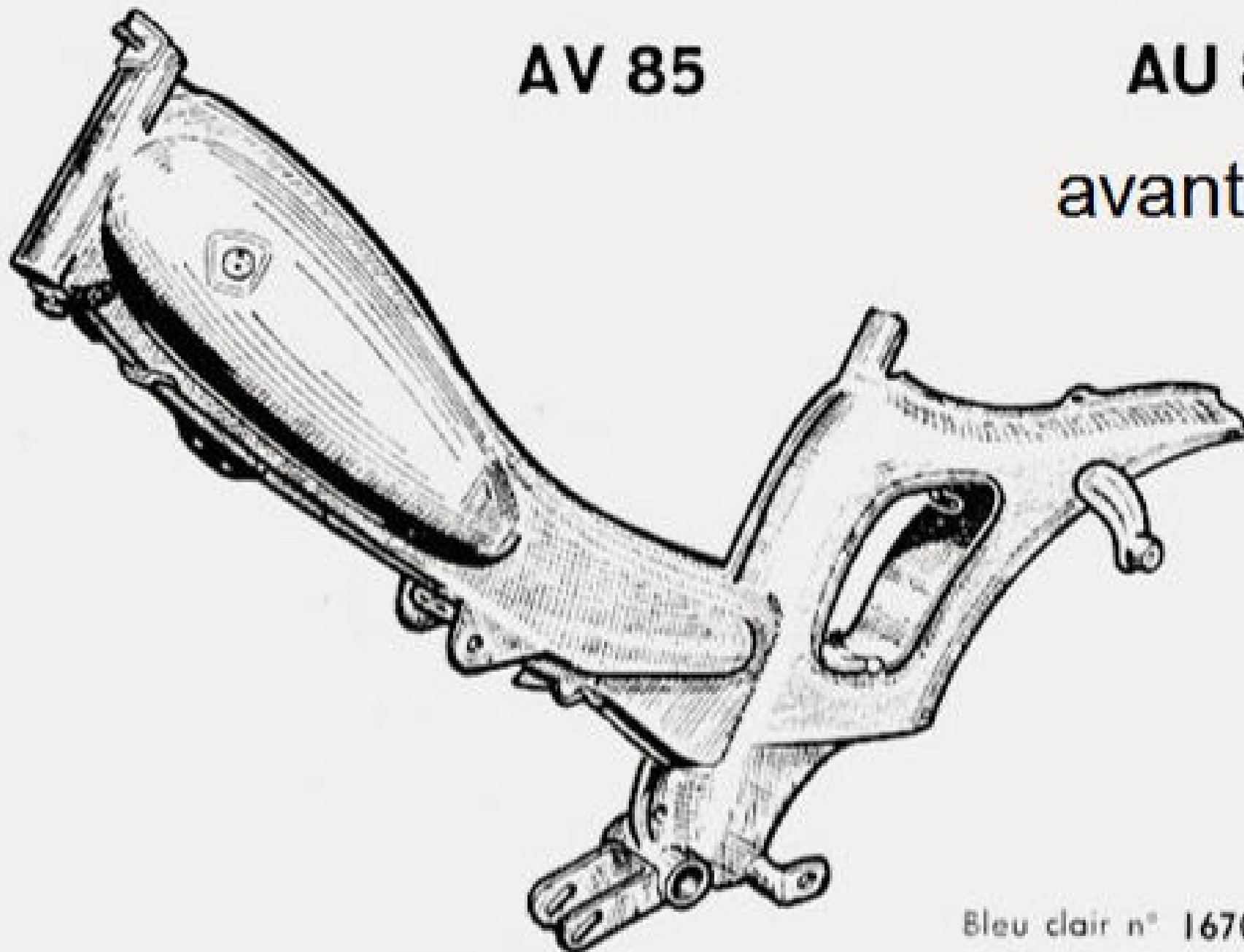

Bleu clair n° 16709



# MOBYLETTE AV85 après 1964

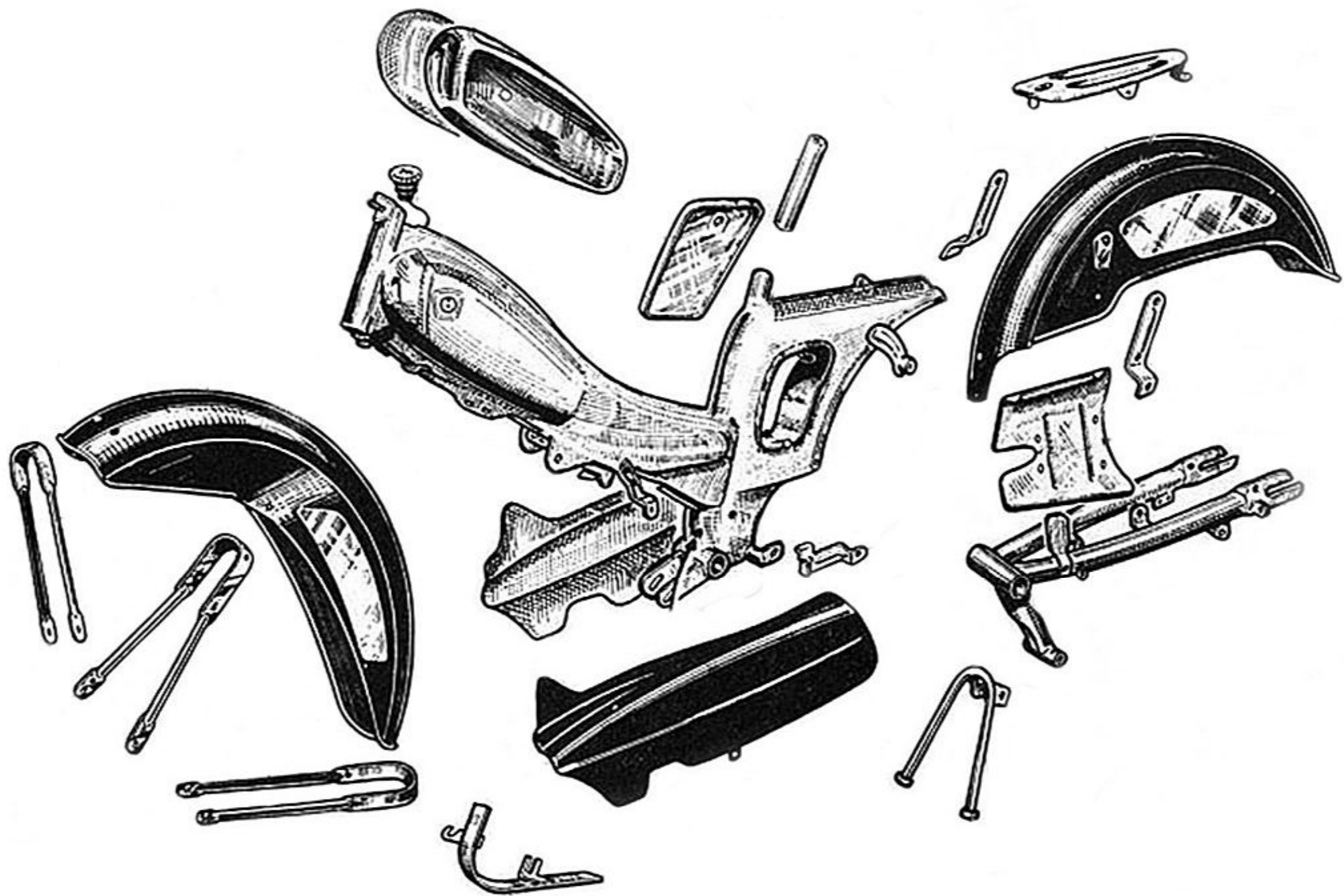

# MOBYLETTE

Type AV 87 ou AU 87

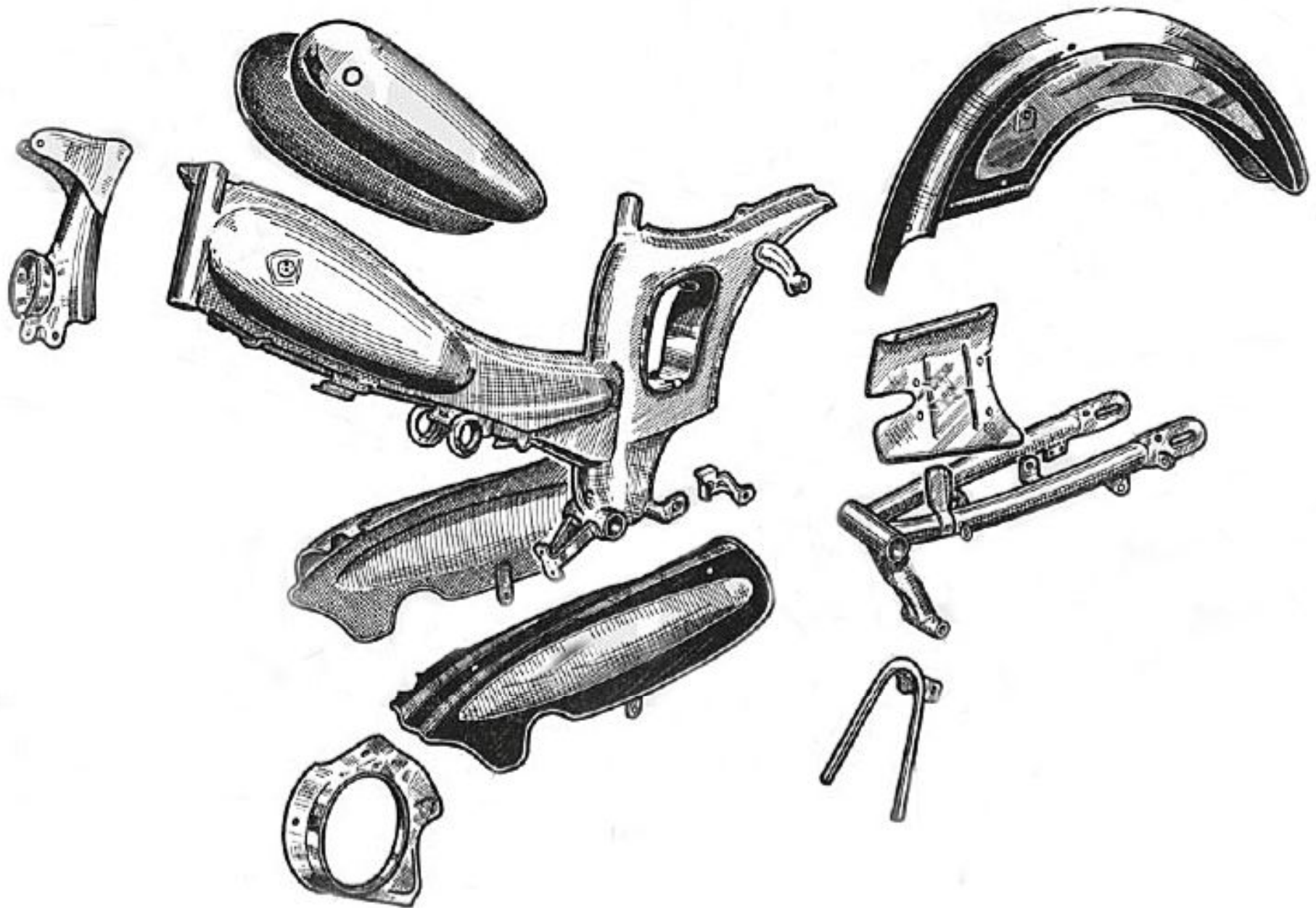

**AV 87**

**AU 87**

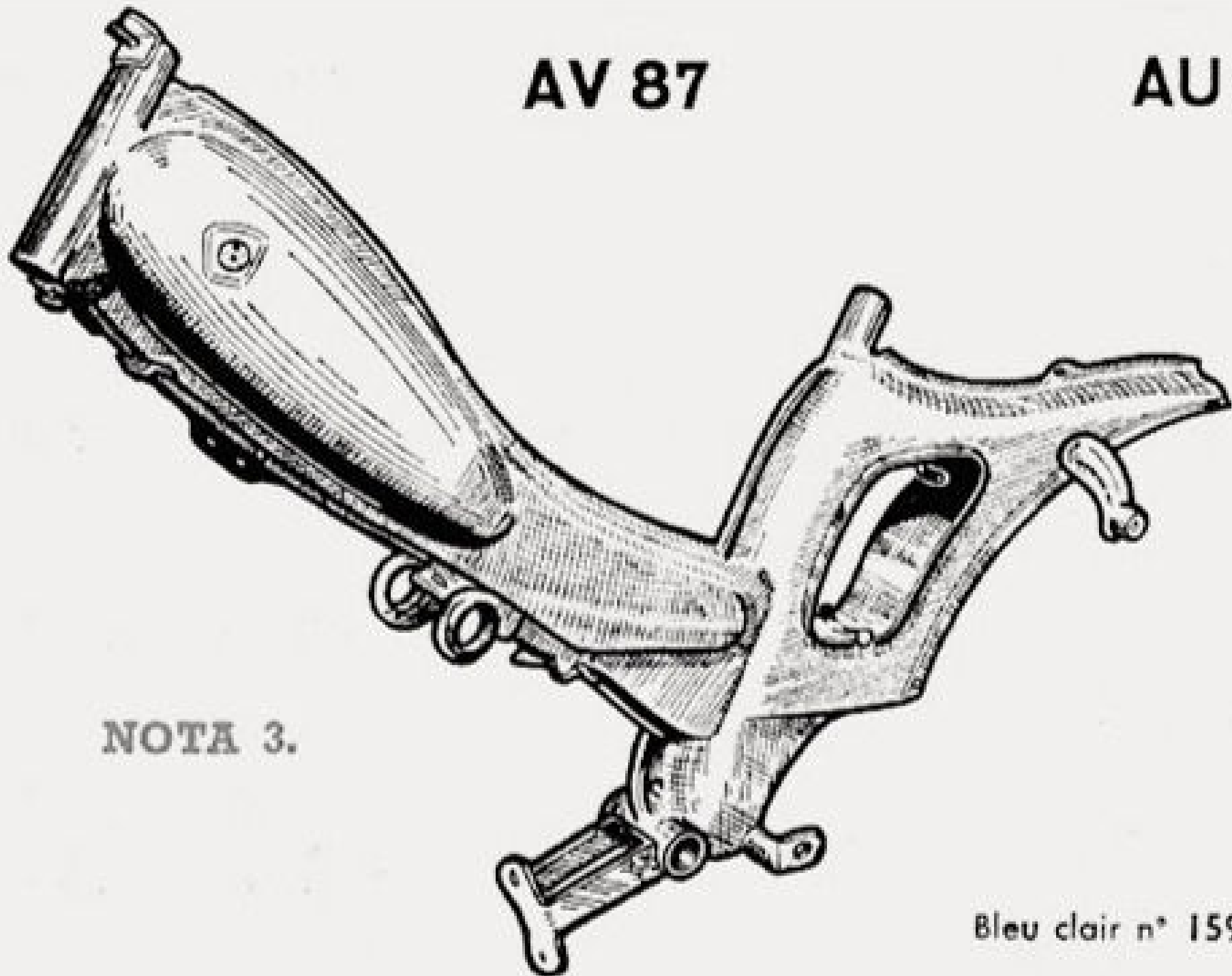

**NOTA 3.**

Bleu clair n° 15913

# MOBYLETTE

Type AV 88 ou AU 88 avant 1964

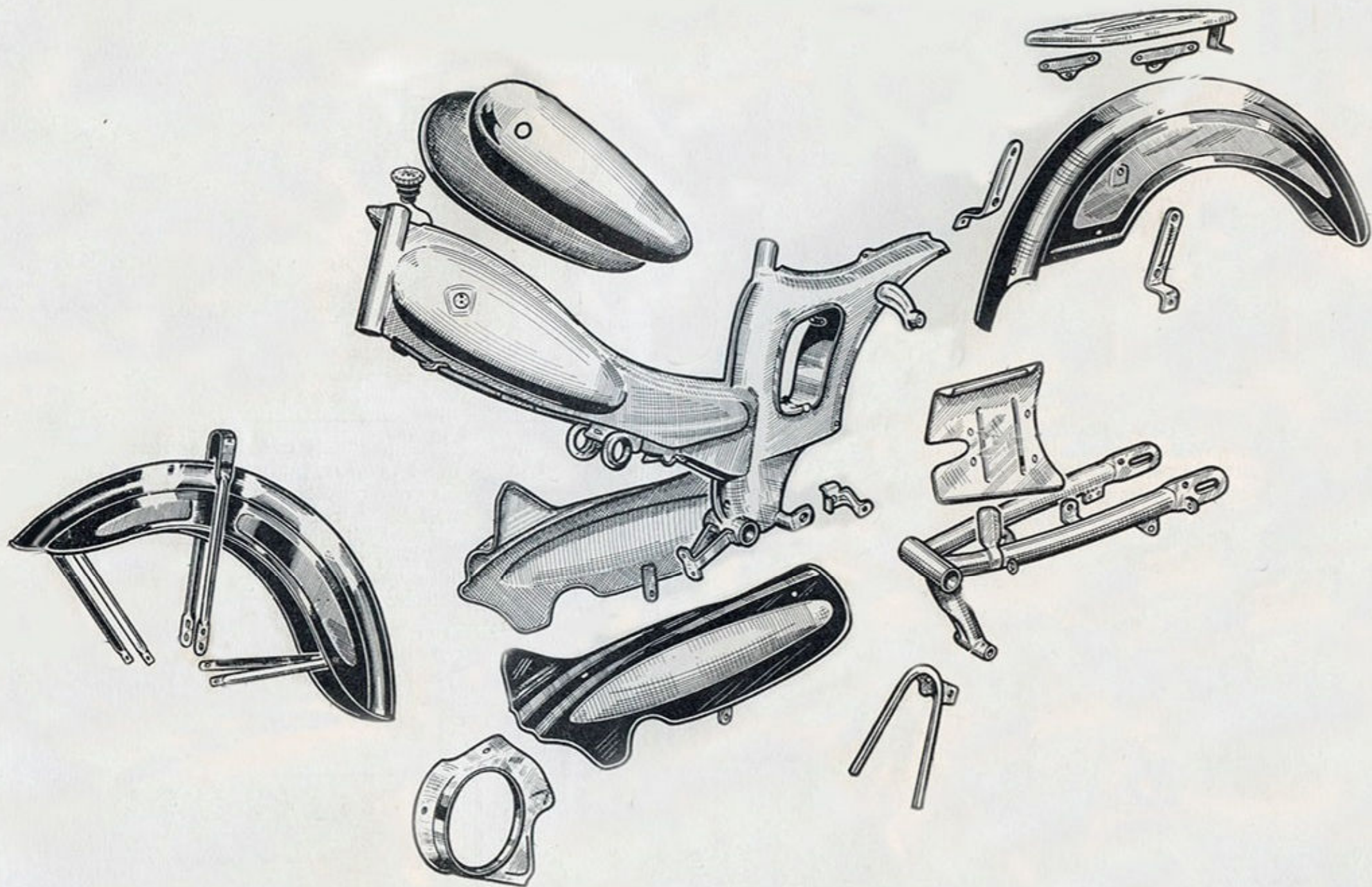

**AV 88**

**AU 88**

**avant 1964**

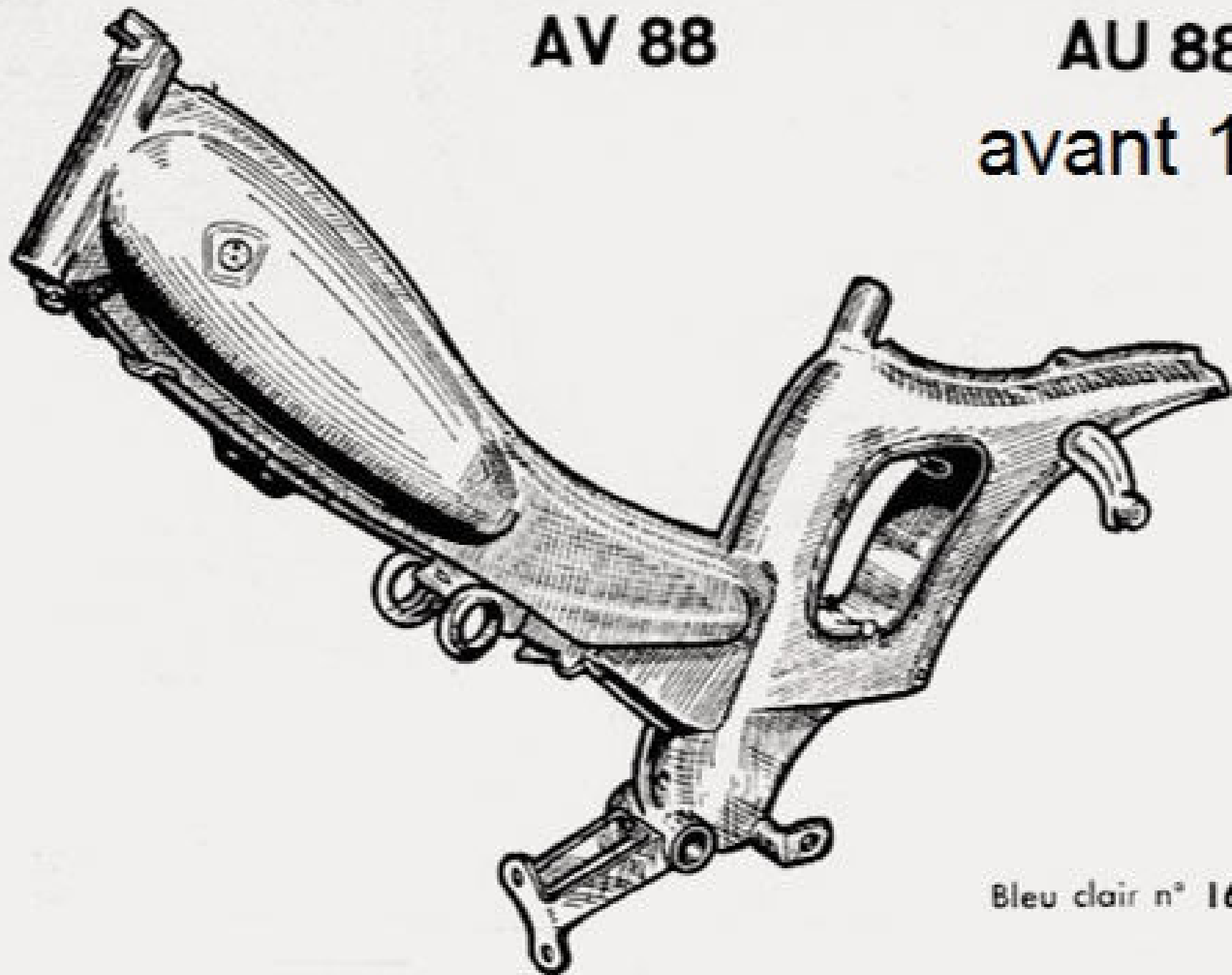

Bleu clair n° 16754

# MOBYLETTE

Type AV 88 ou AU 88 après 1964

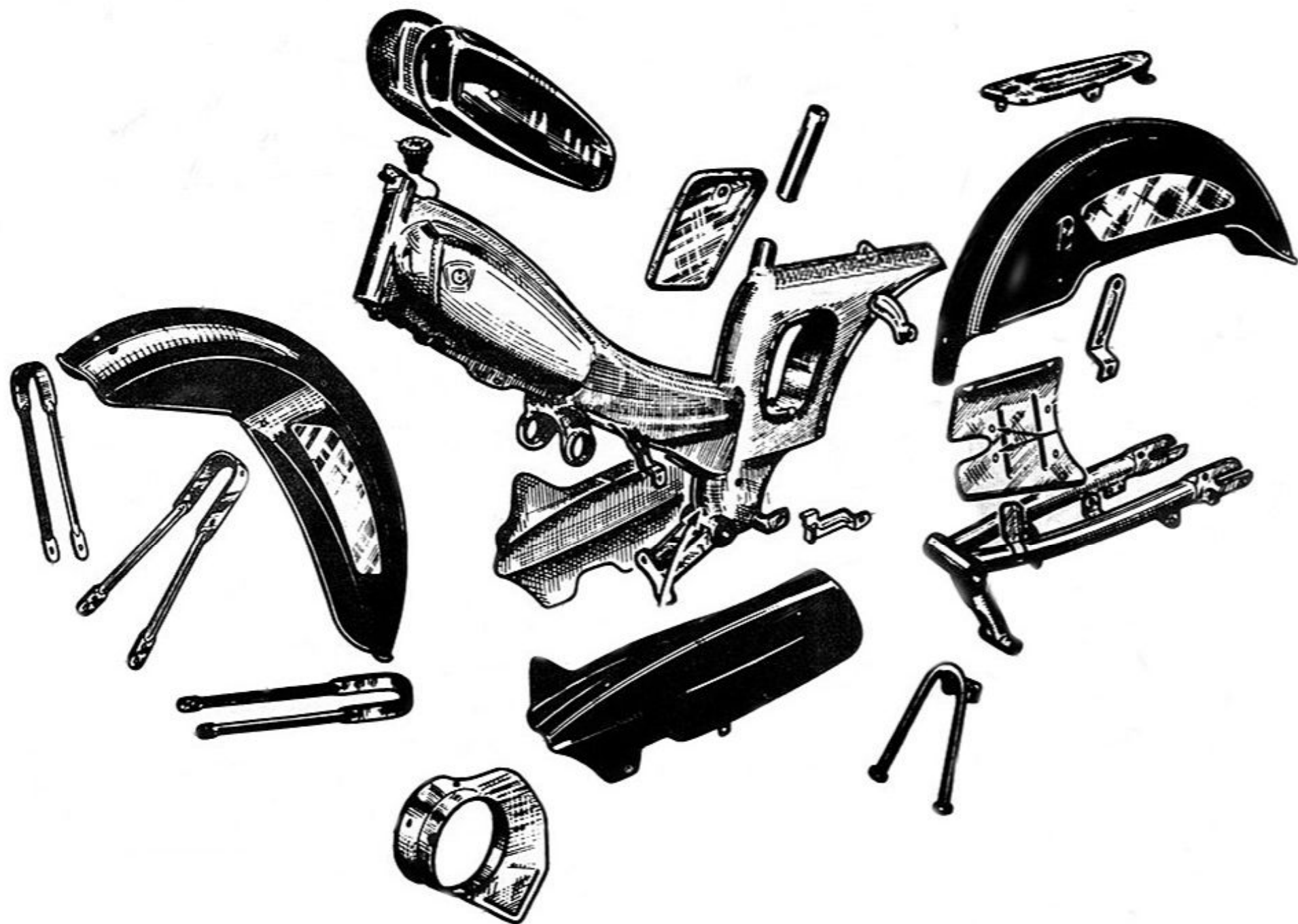

# MOBYLETTE

Type AV 89 ou AU 89

avant 1963

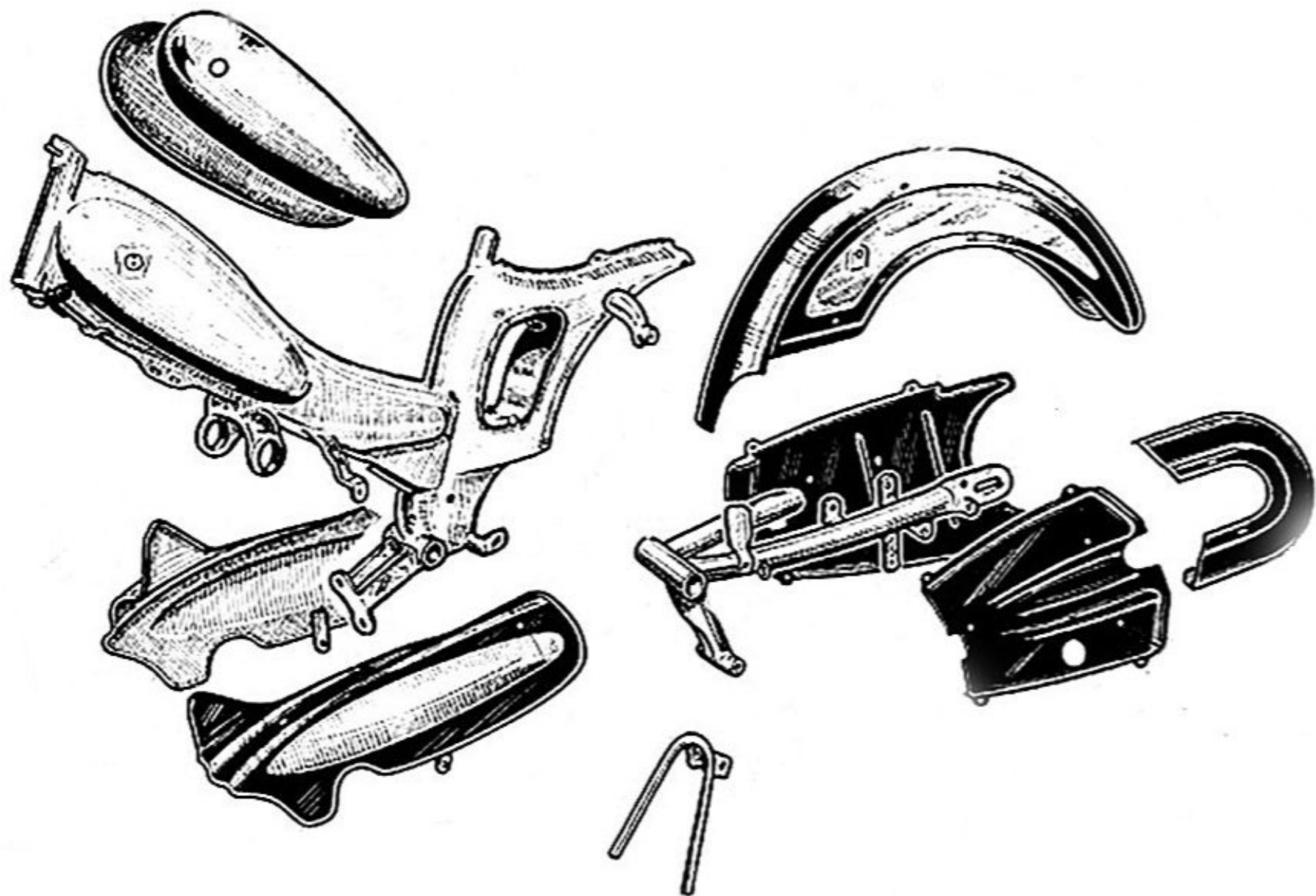

**AV 89**

**AU 89**

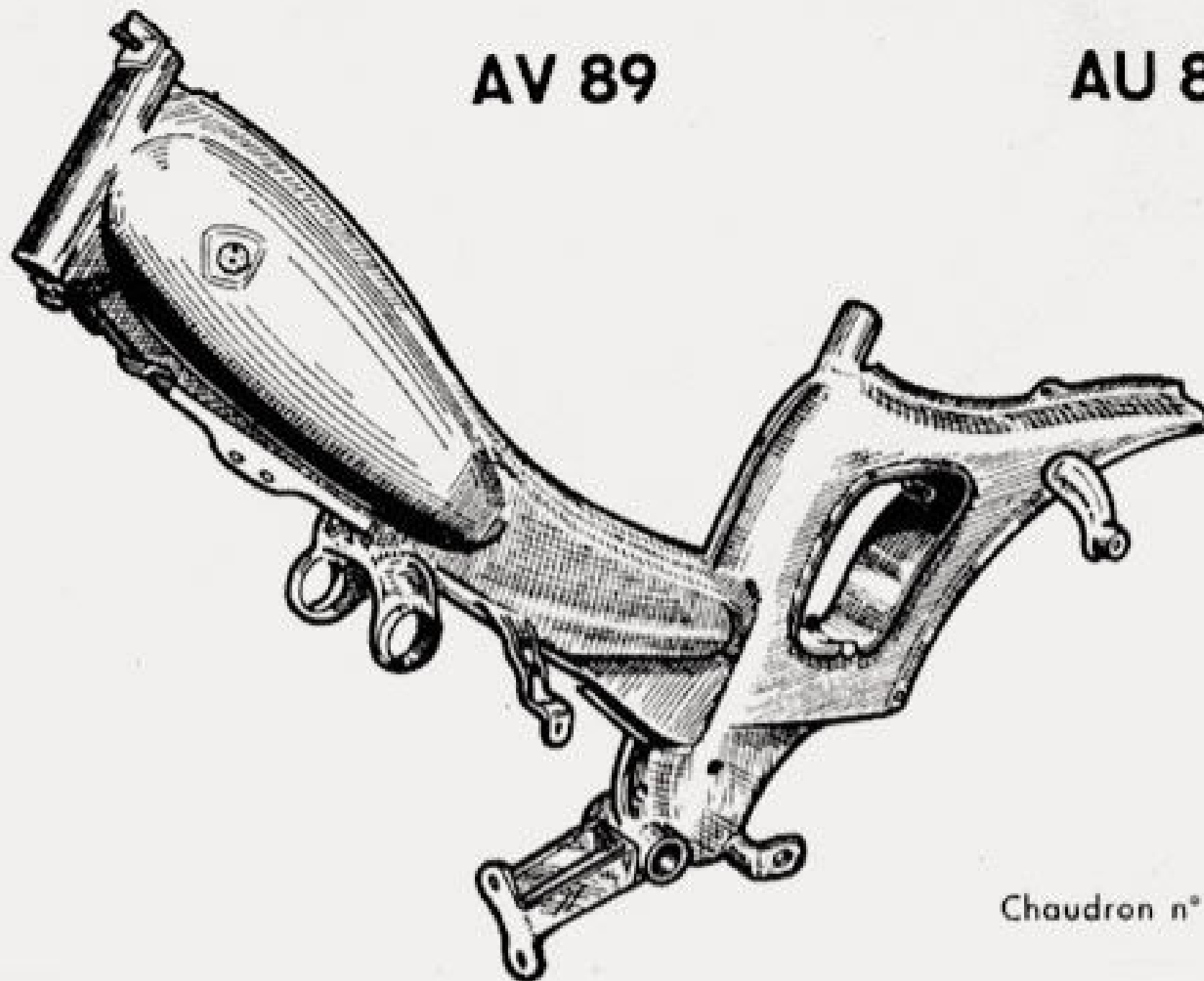

Chaudron n° 17001



# MOBYLETTE

Types AV ou AU 89

après 1963

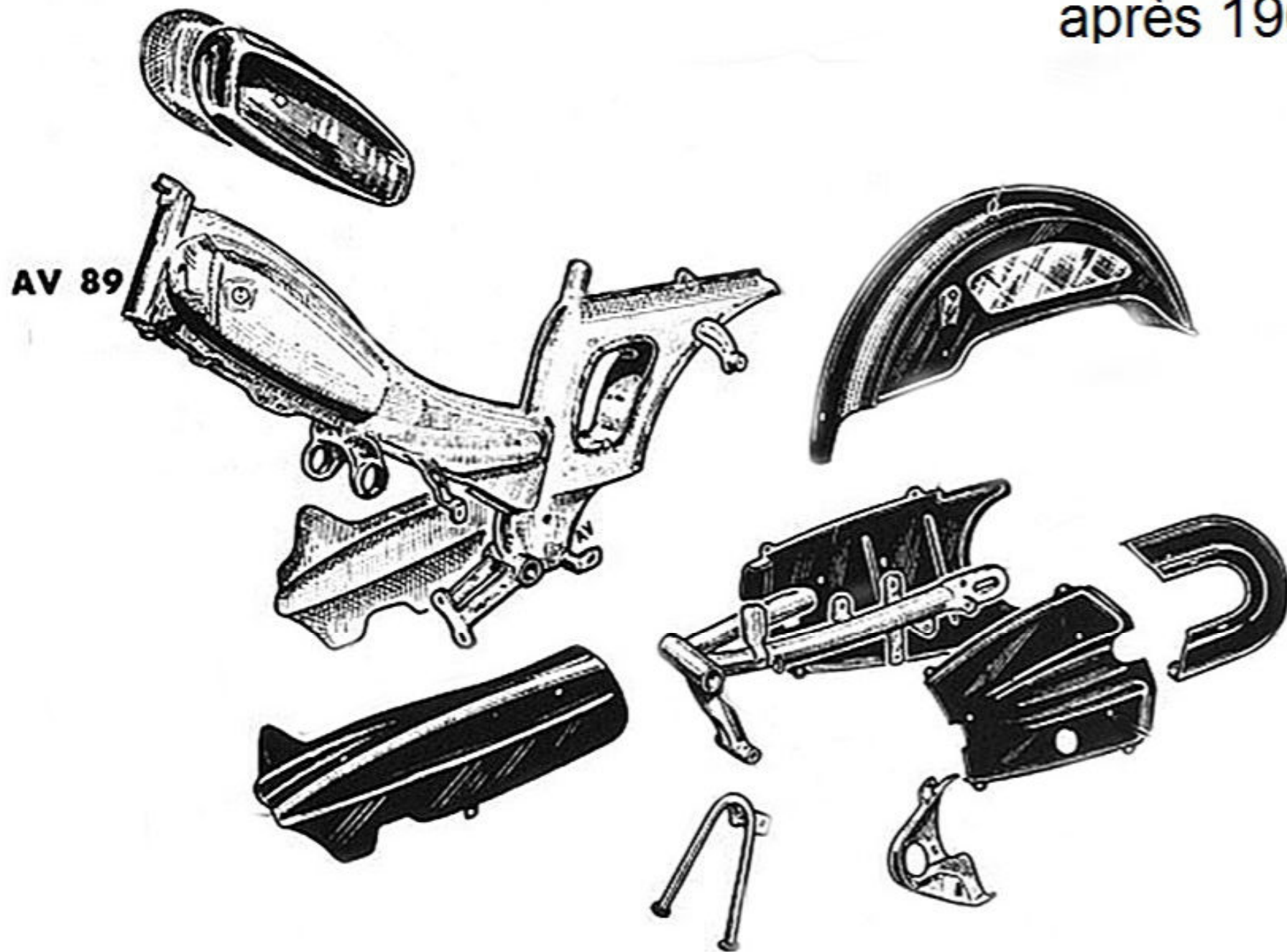

# Type AV 89 or AU 89

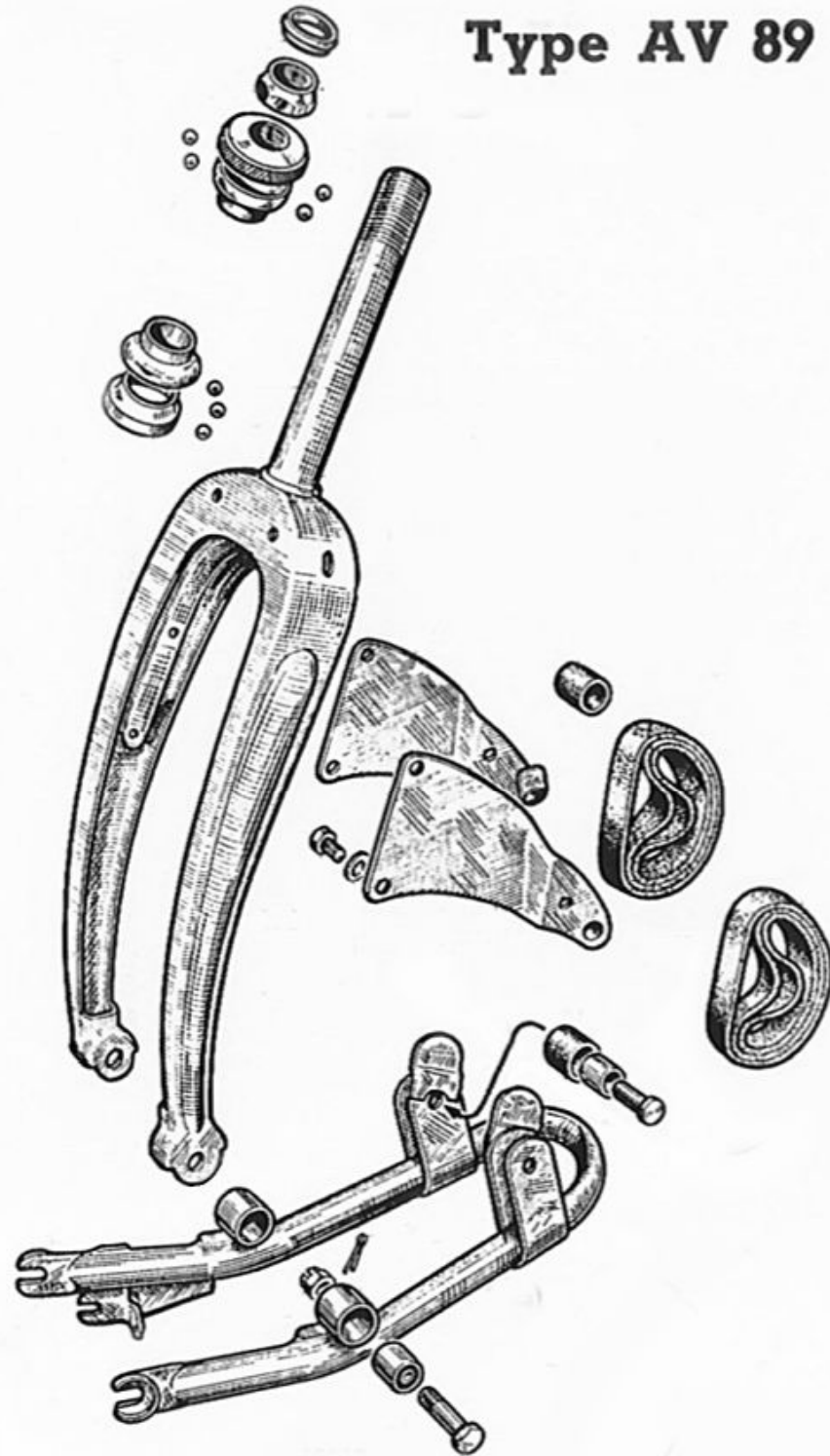

**MOBYLETTE**

**Types AV ou AU 89 version 4 1966**

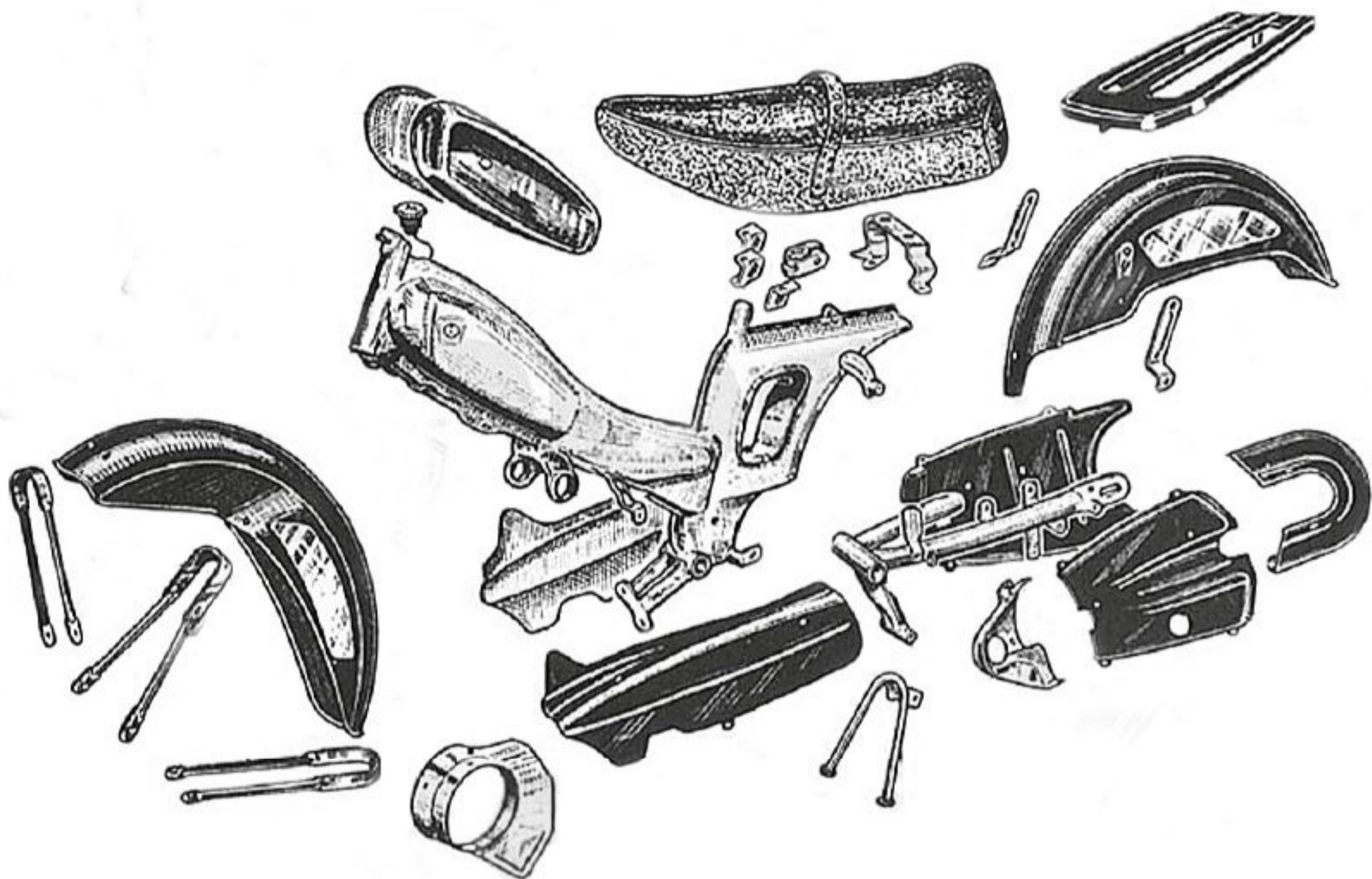

# MOBYLETTE

Type AV 98 ou AU 98

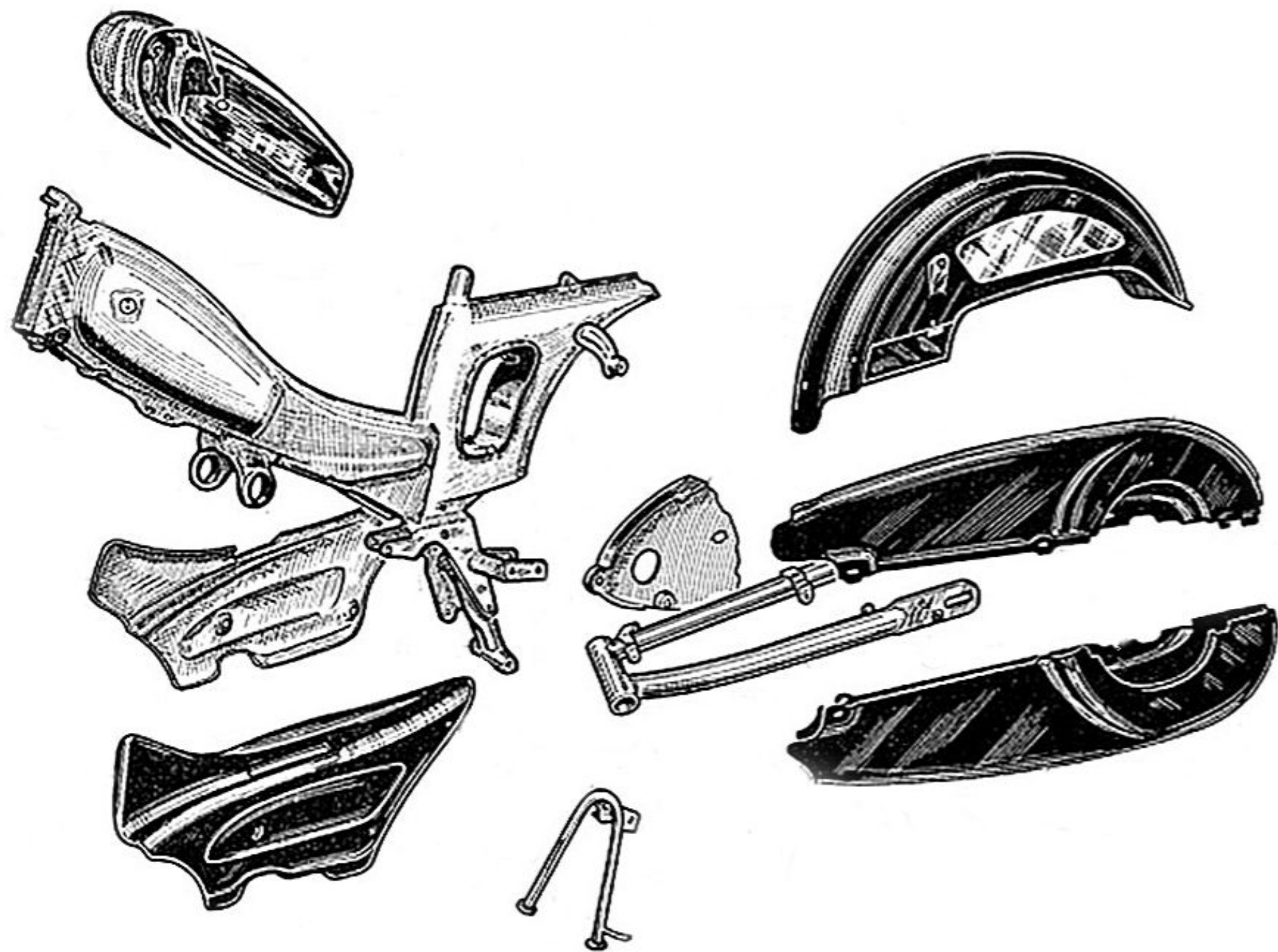

# MOBYLETTE Type BG ou CG

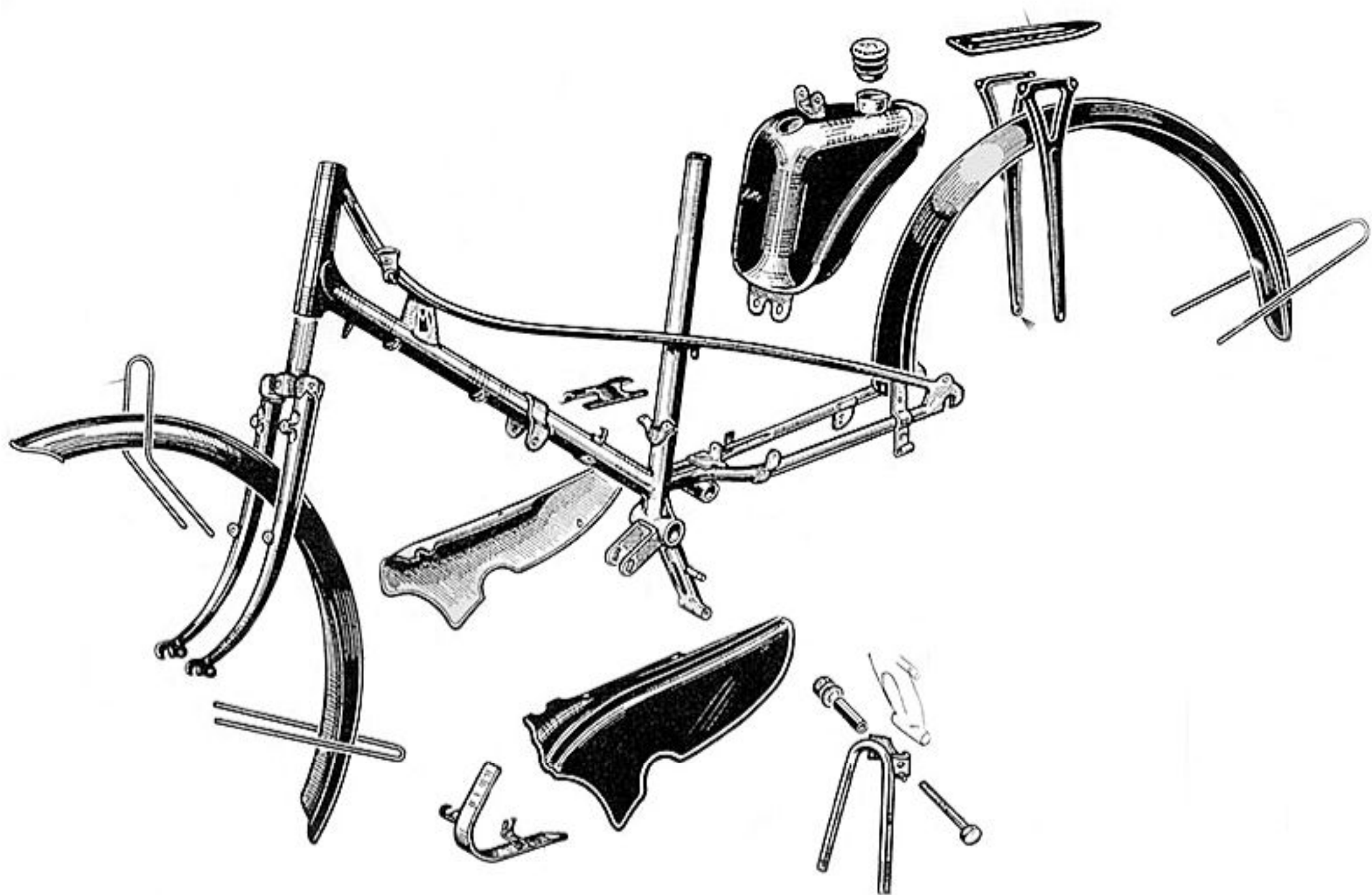

BG

CG

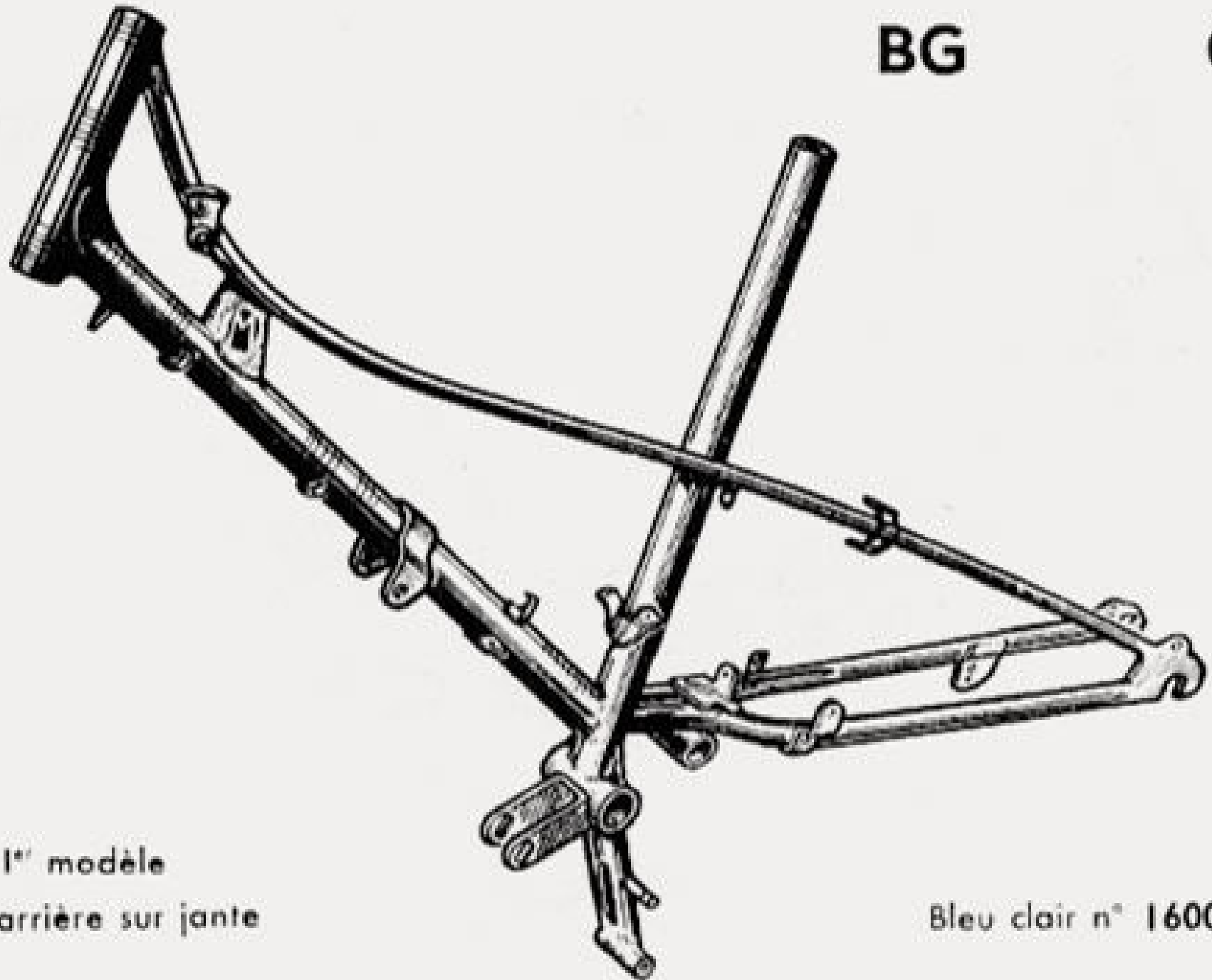

1<sup>er</sup> modèle

Frein arrière sur jante

Bleu clair n° 16001

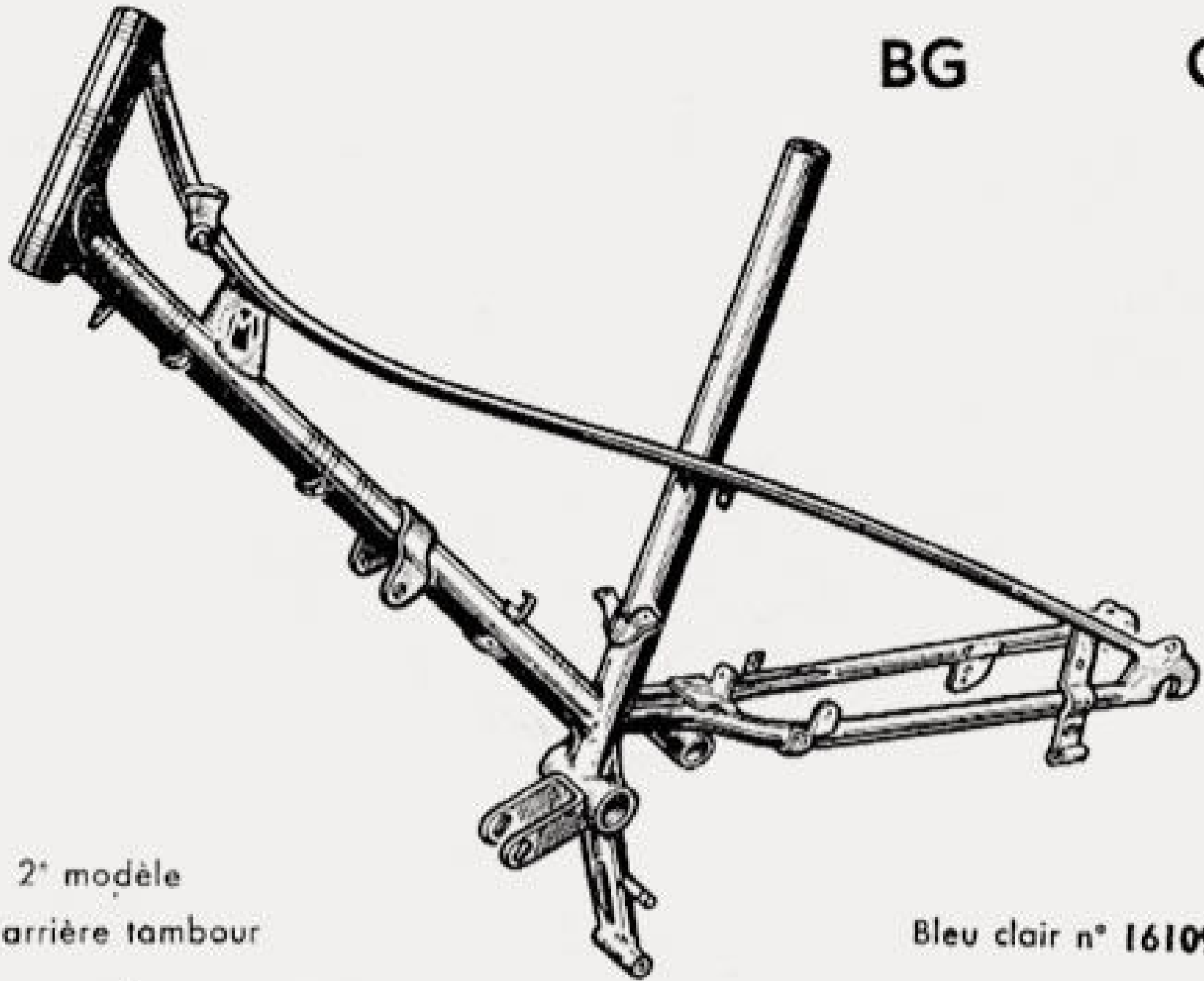

**BG**

**CG**

2<sup>e</sup> modèle  
Frein arrière tambour

Bleu clair n° 16109

# MOBYLETTE Type BG 43 ou CG 43

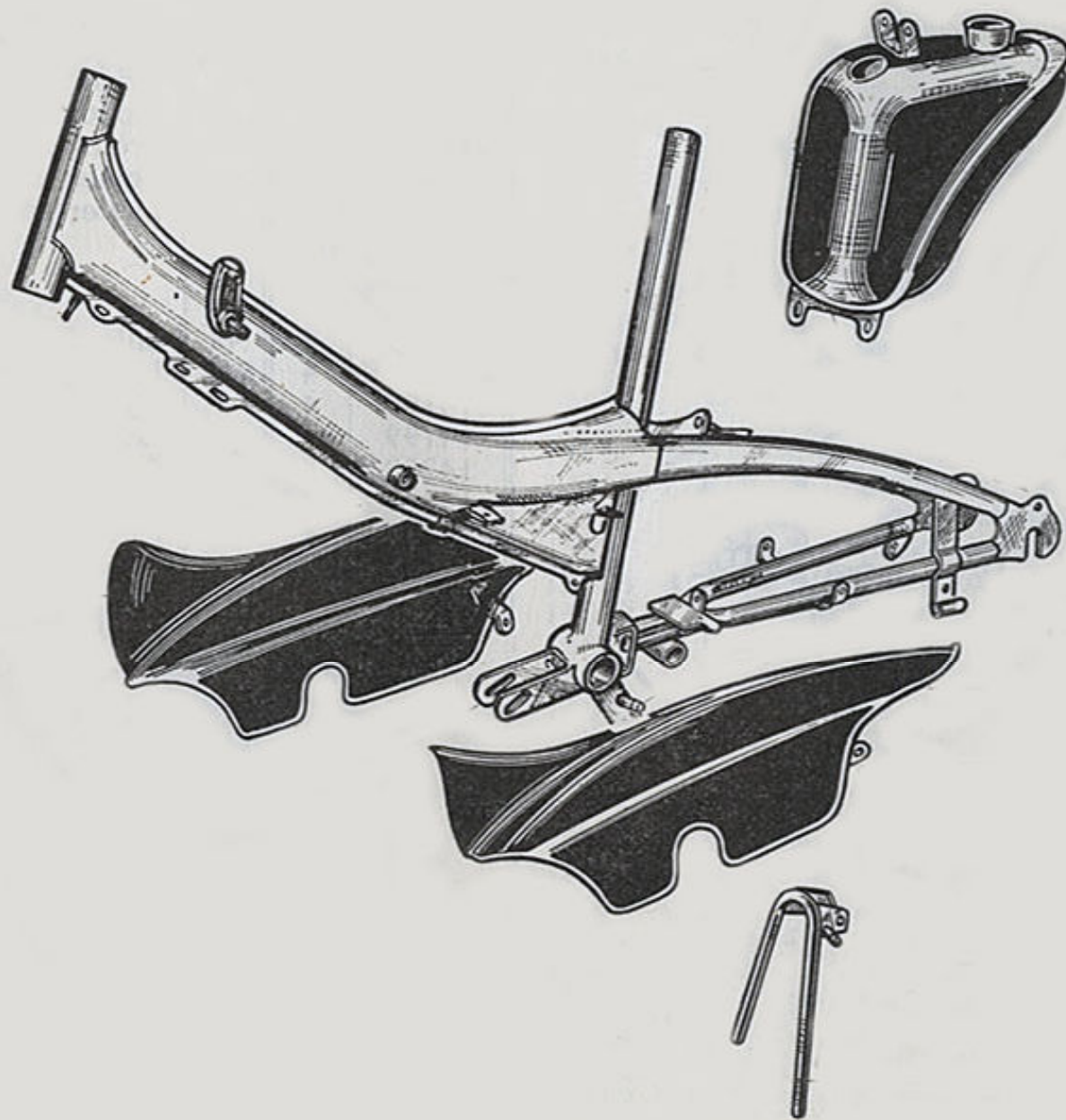



# CYCLOMOTEUR "CADY"

Type M 1 ou C 1

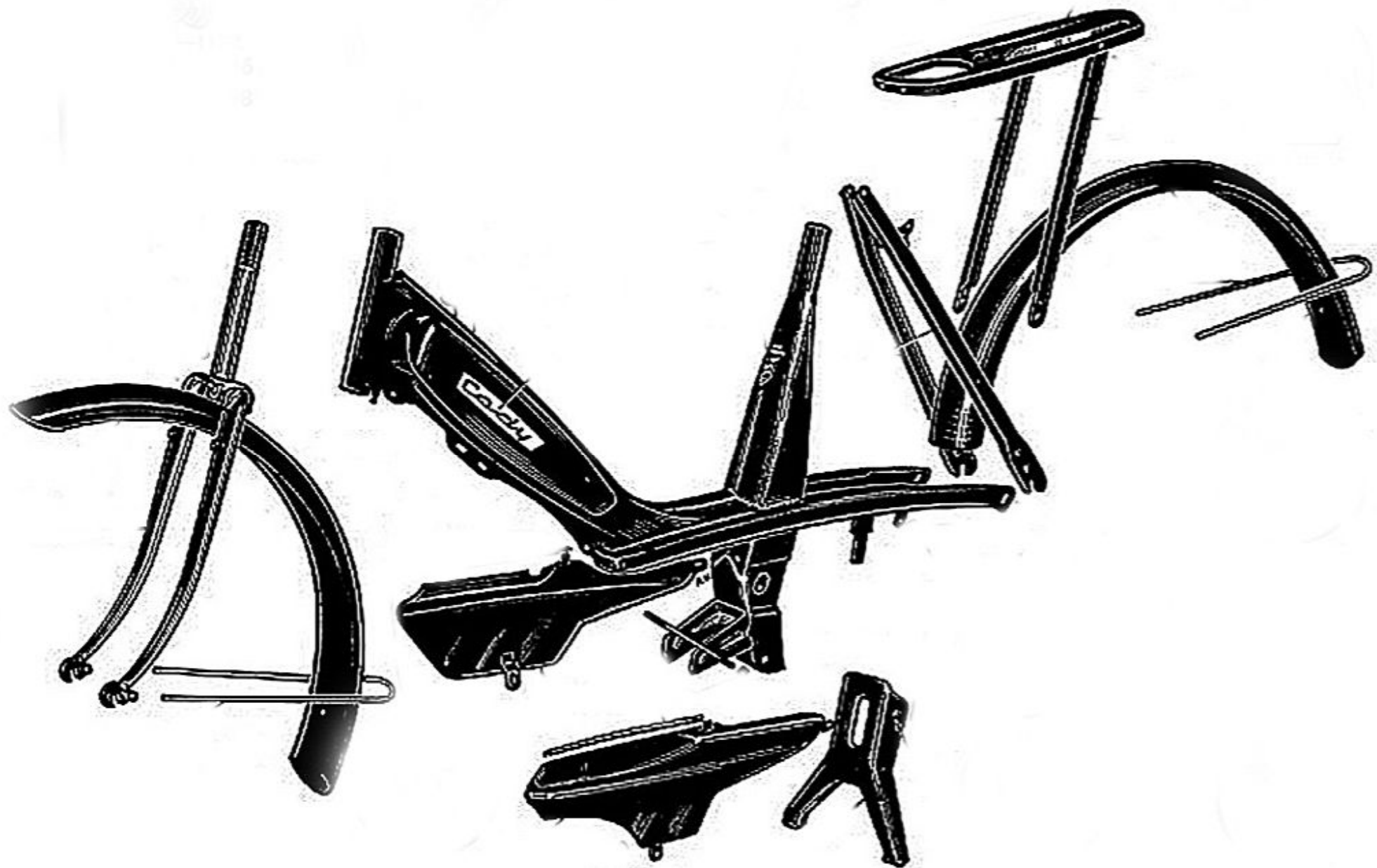

caravane  
voiture  
bateau...

leur  
complément :

**Cady**  
démontable

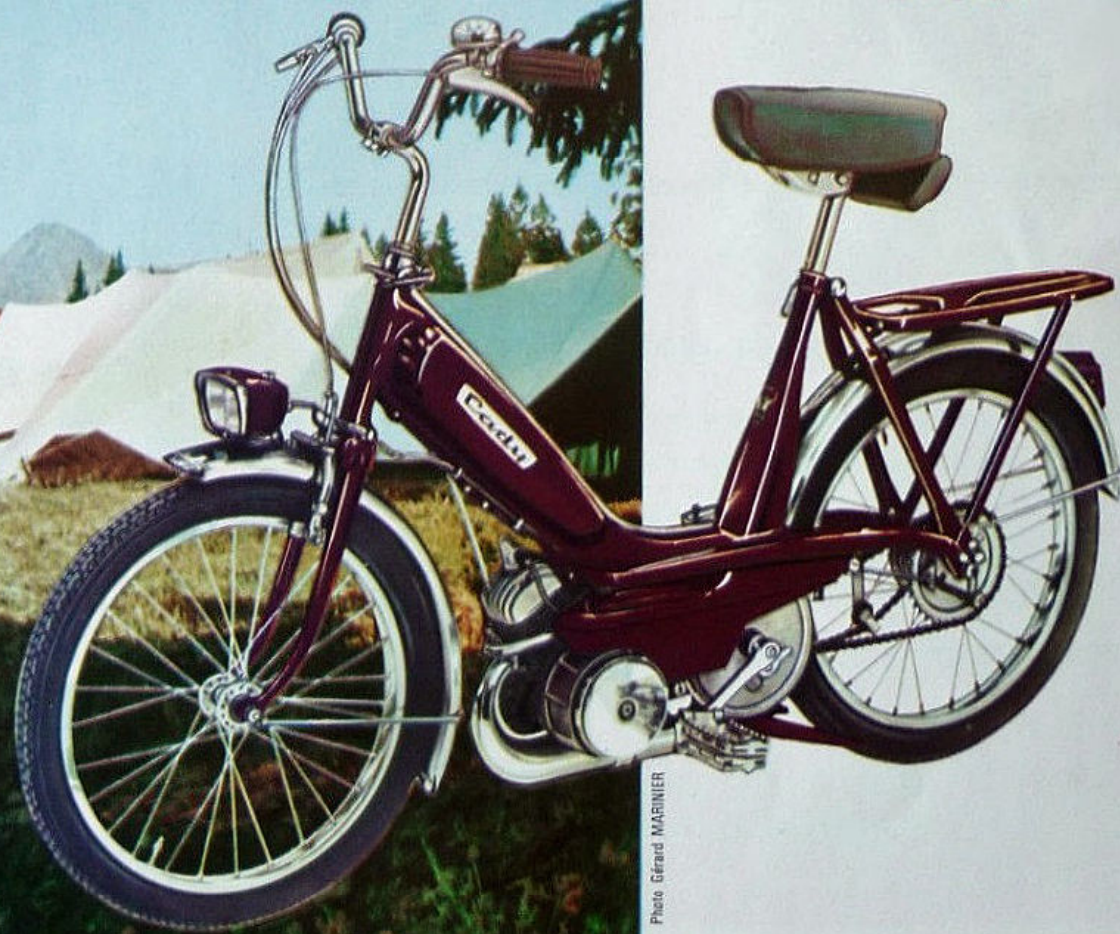

PRIX **548 F** + T.L.

Photo Gérard MARINIER

# M1PR

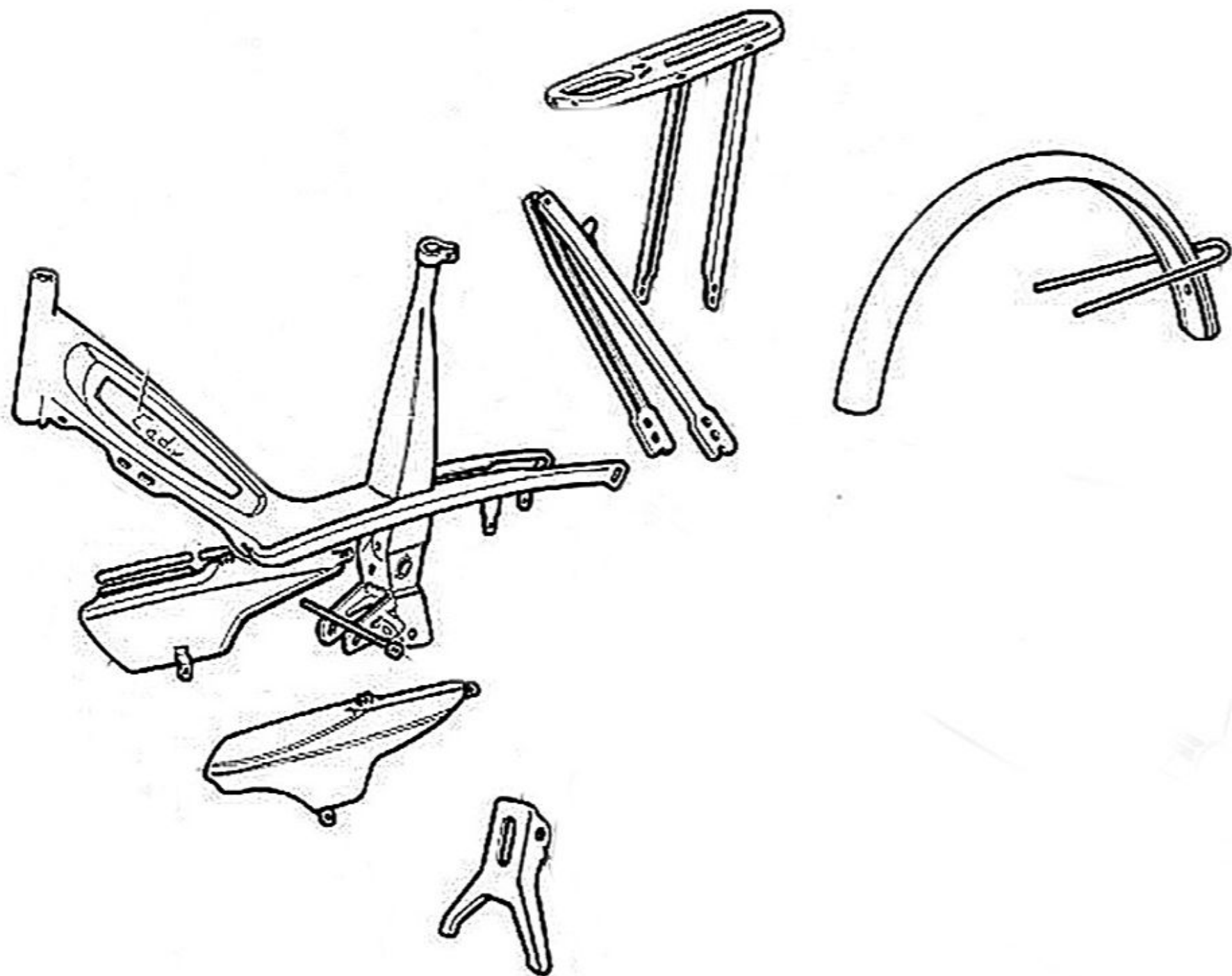

# M 3 PR - M 3 PRT

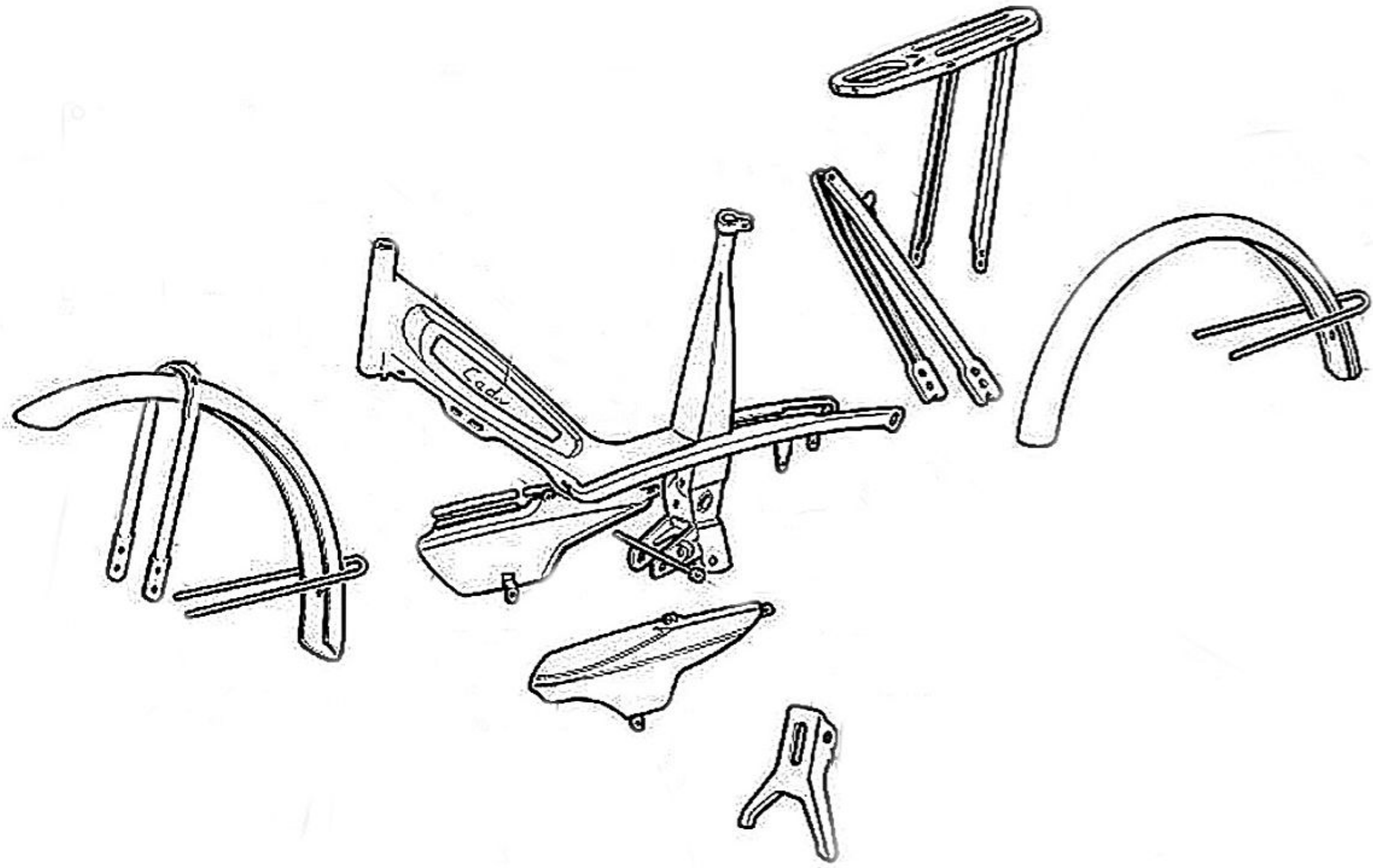

# M 3 PRTS - M 3 PRTSG

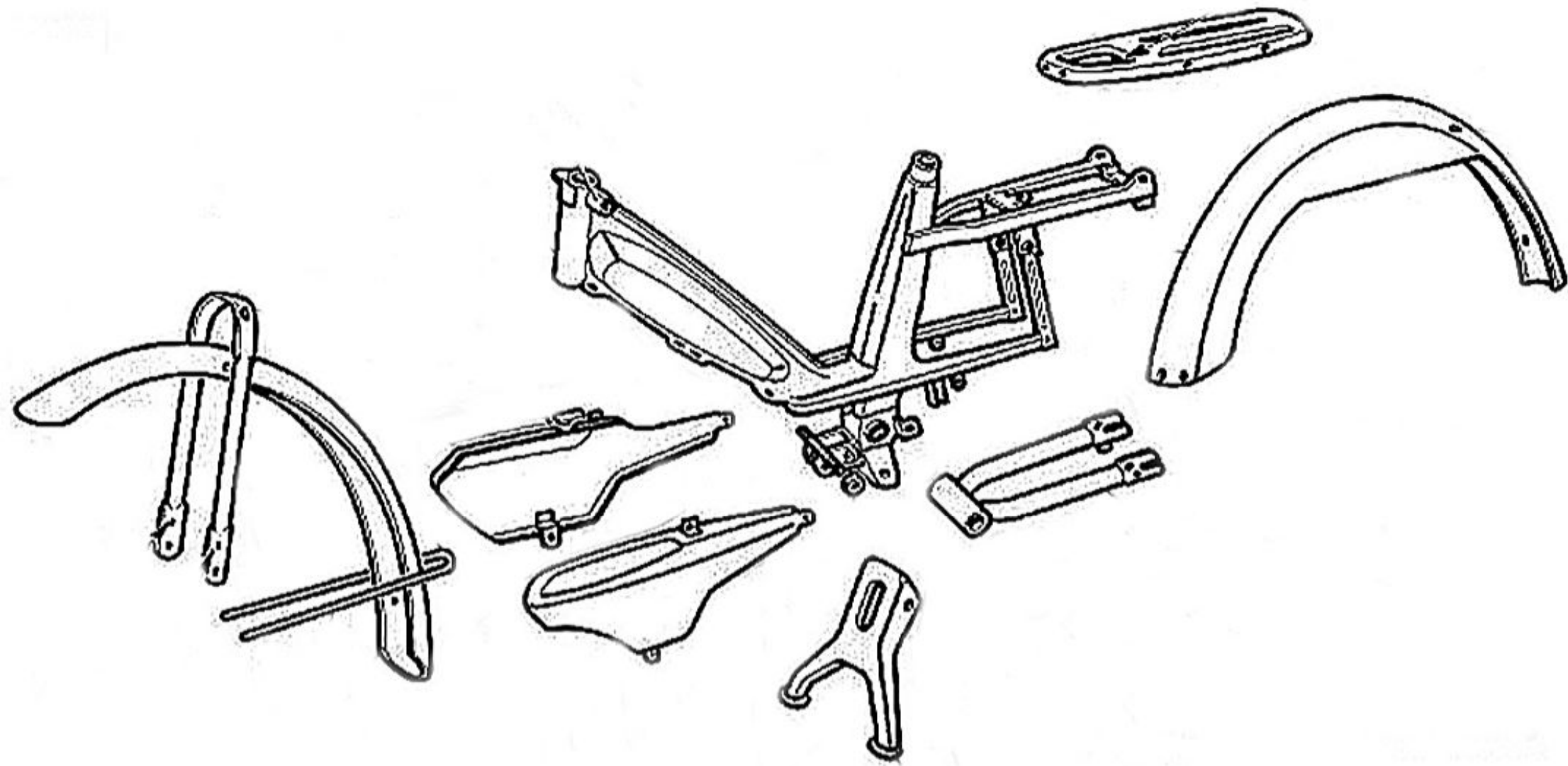

# CRAZY-BIKE

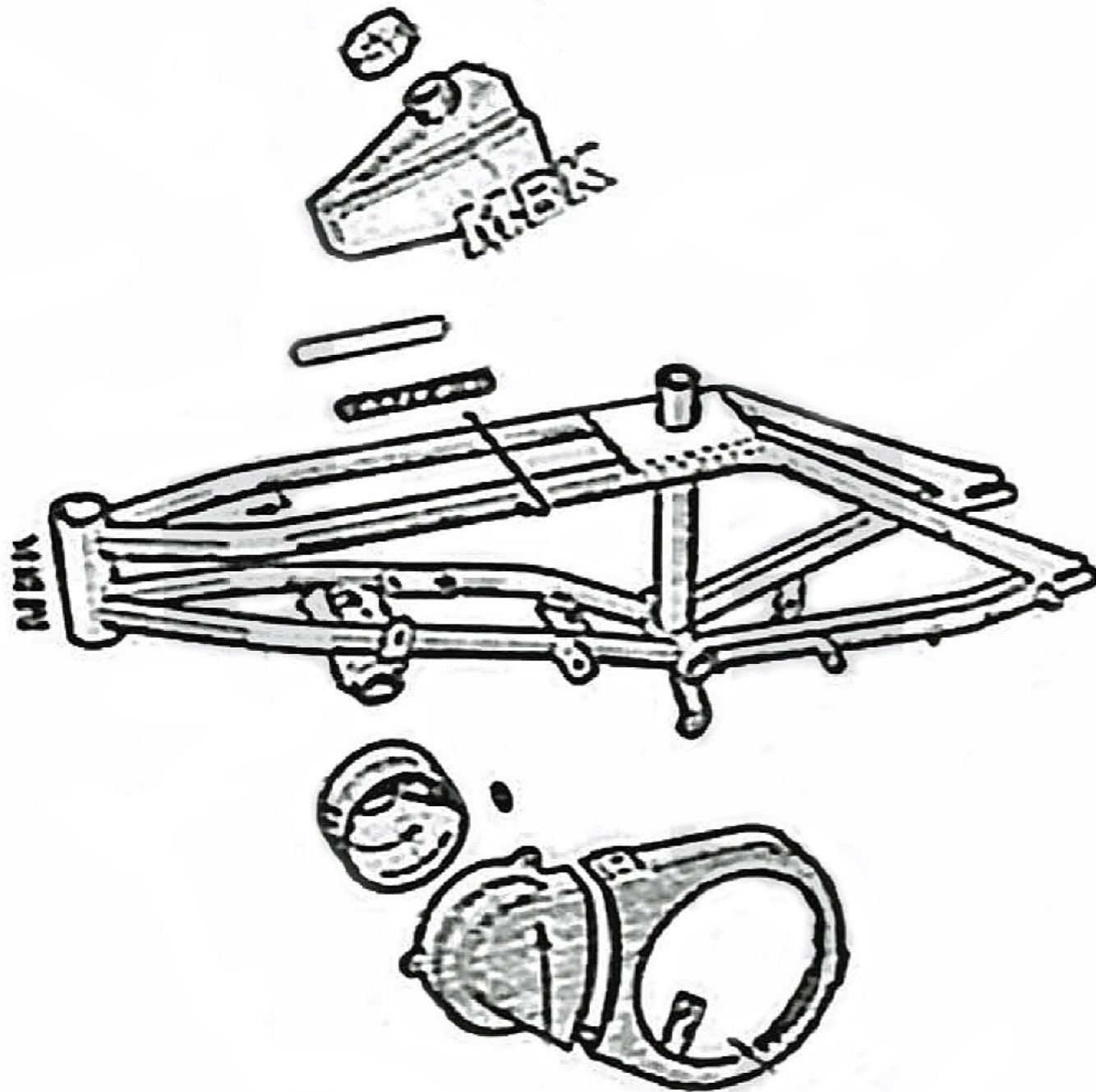

# VELOMOTEUR

Type D 52 ou C 52

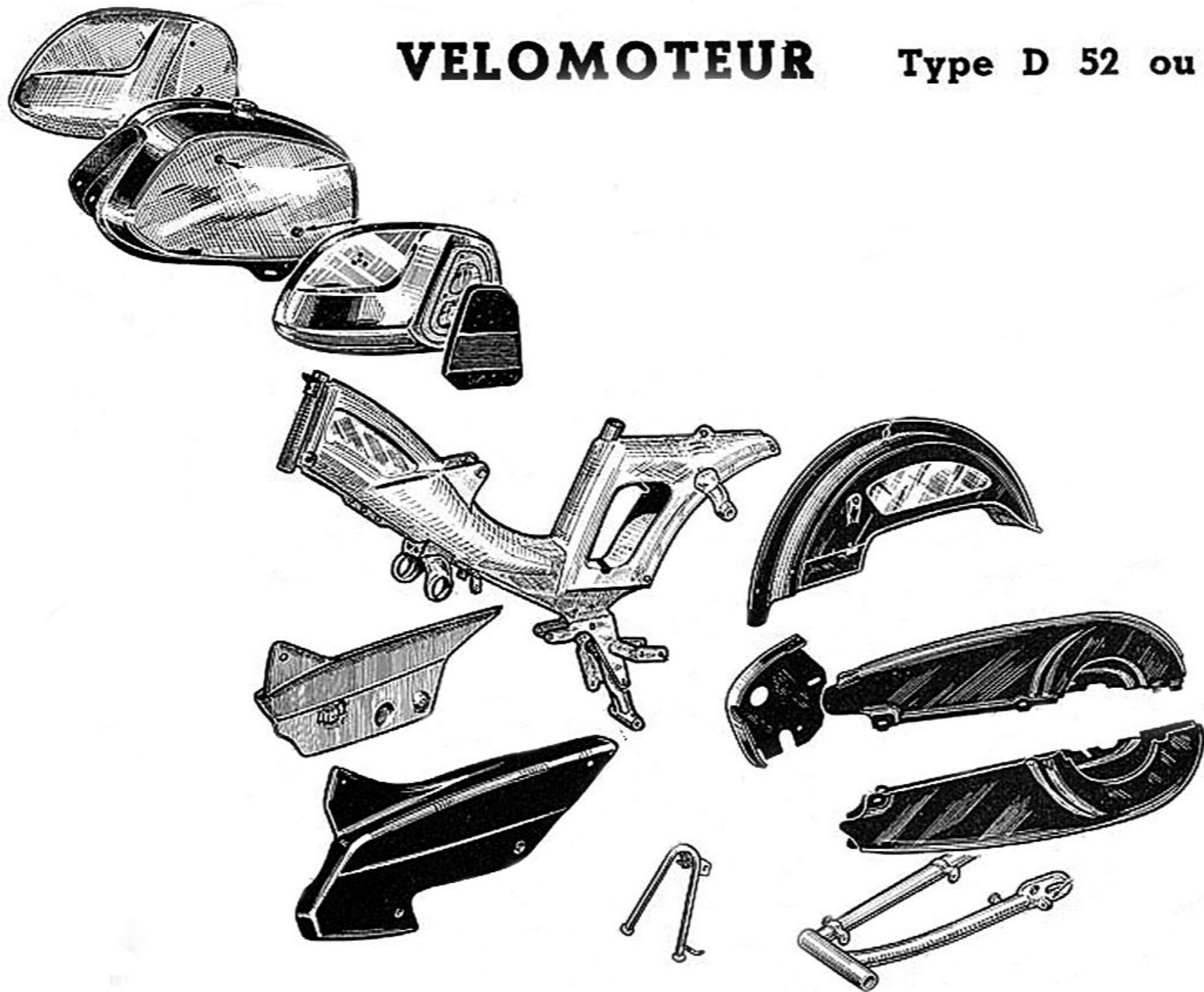

**M** MOTOBECANE D55

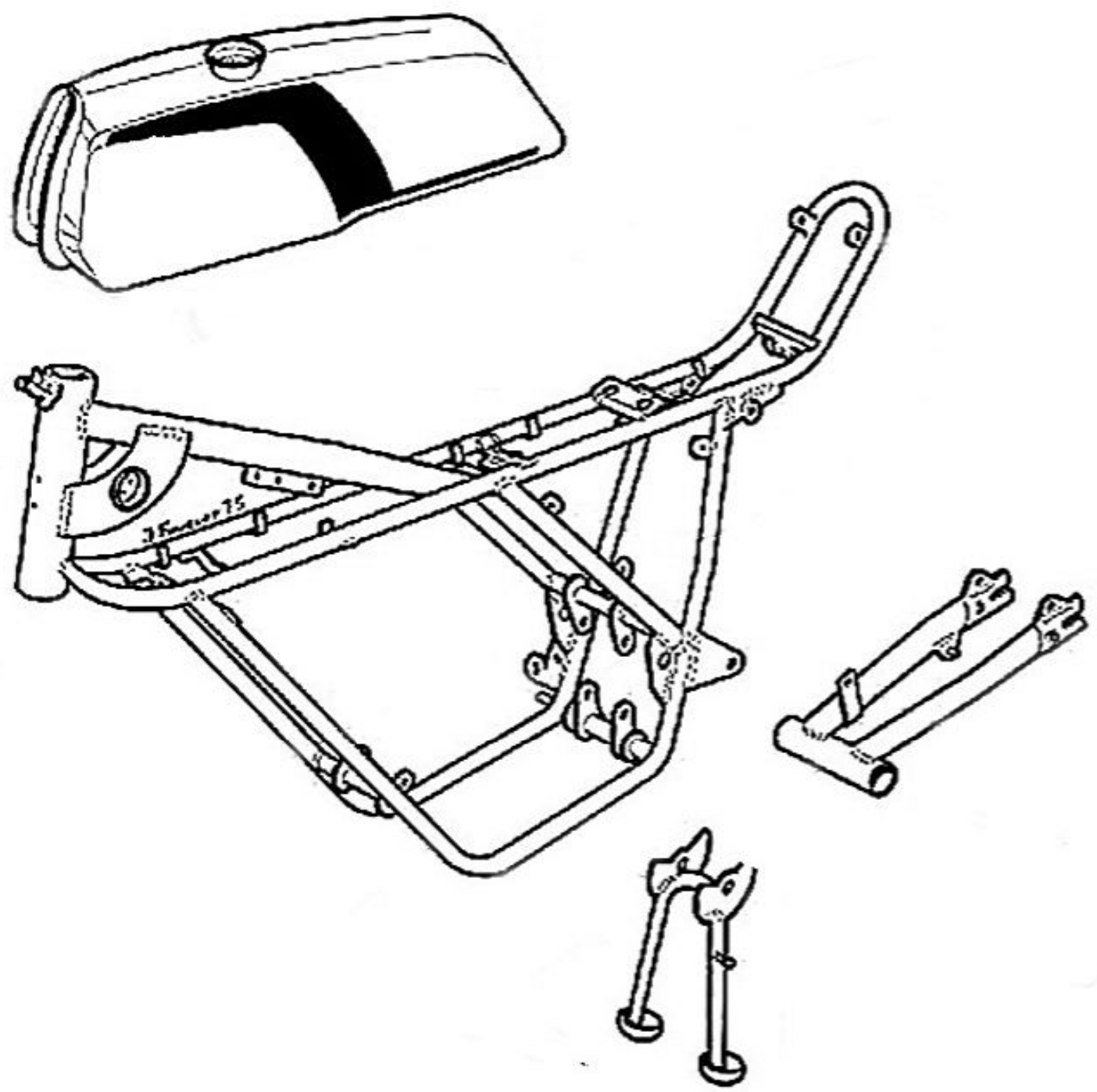





MOTOBECANE  
MOTOCONFORT

**D 55 TRIAL**

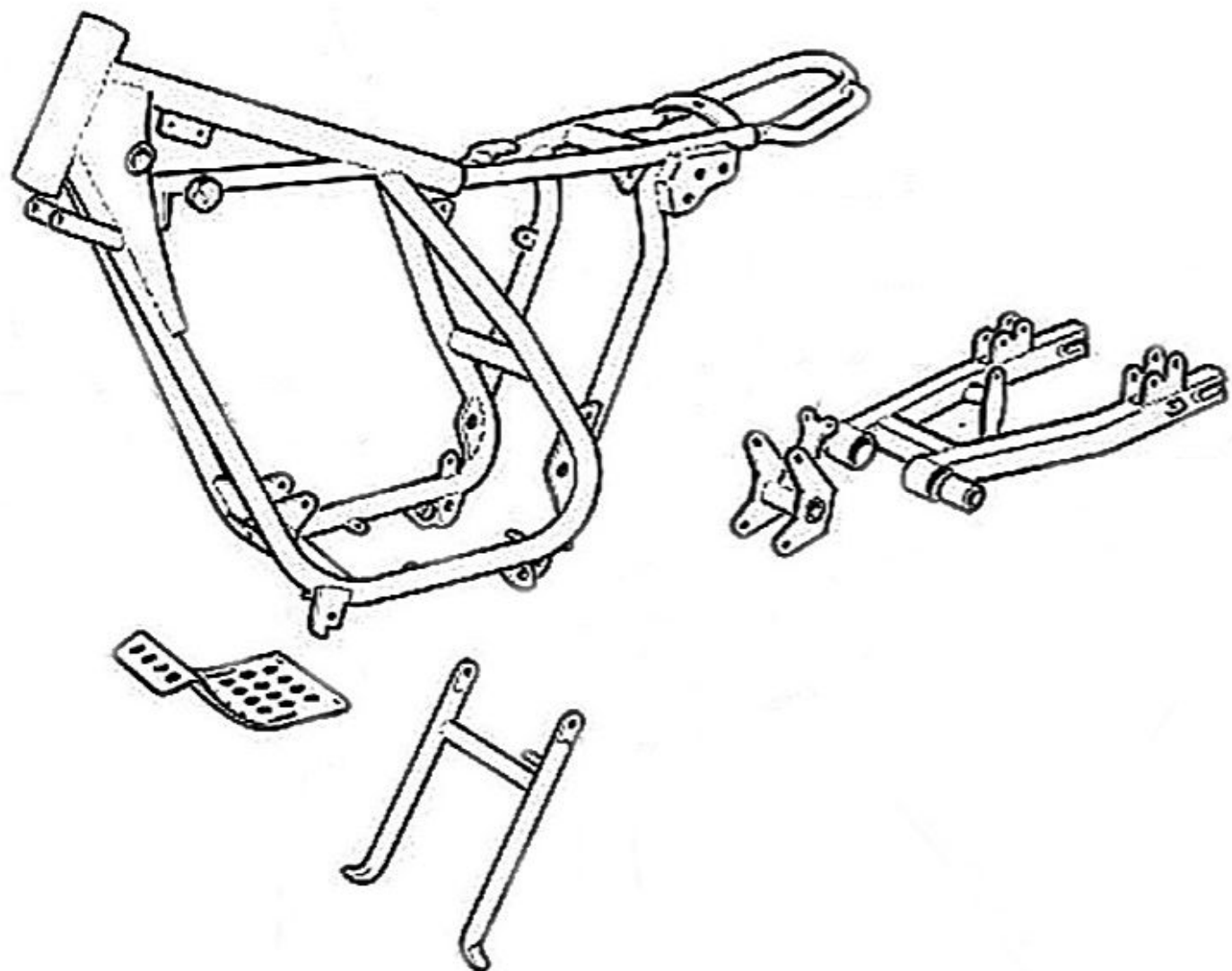



# MOTOBECANE D55TT 79

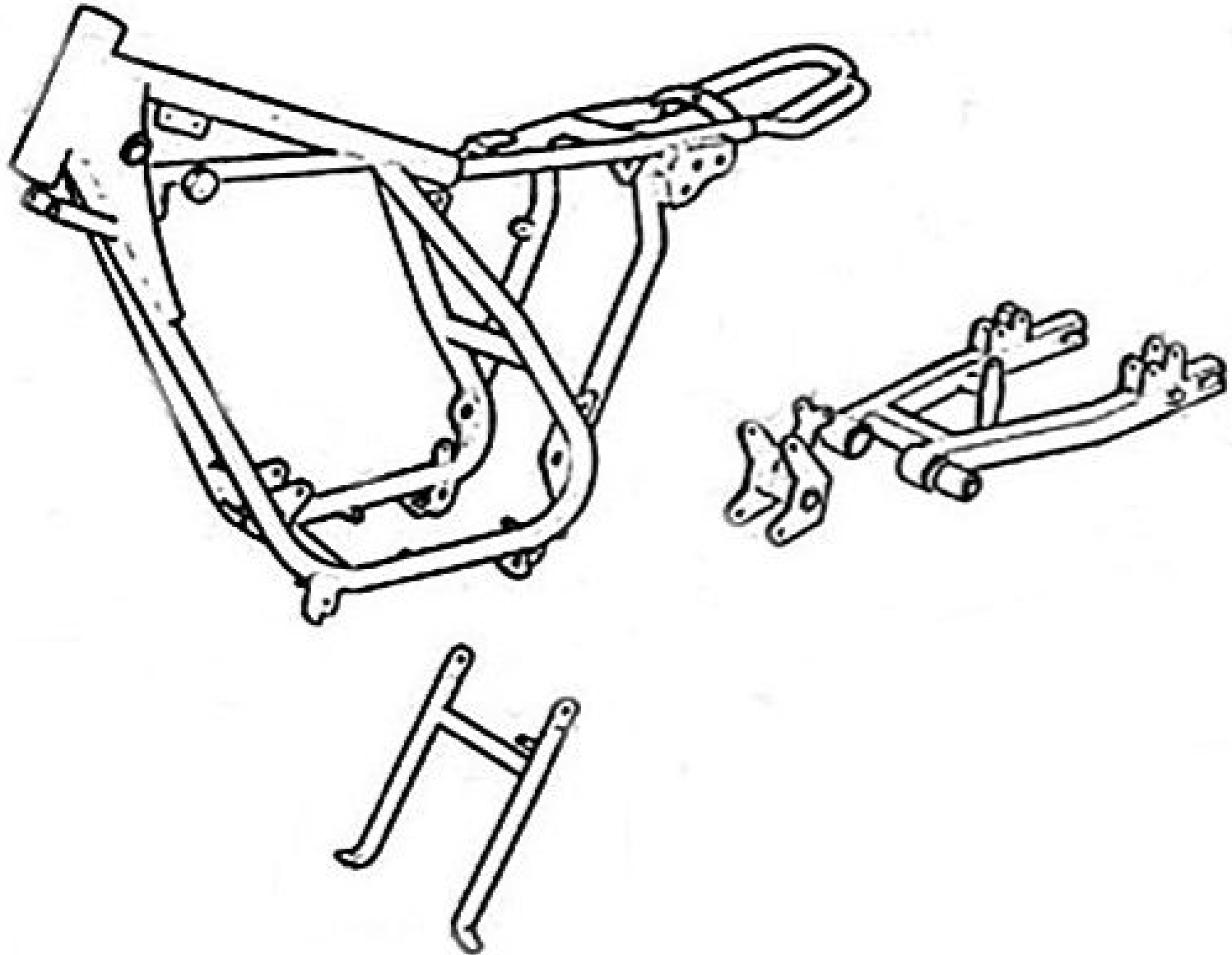

# MOTOBECANE D75

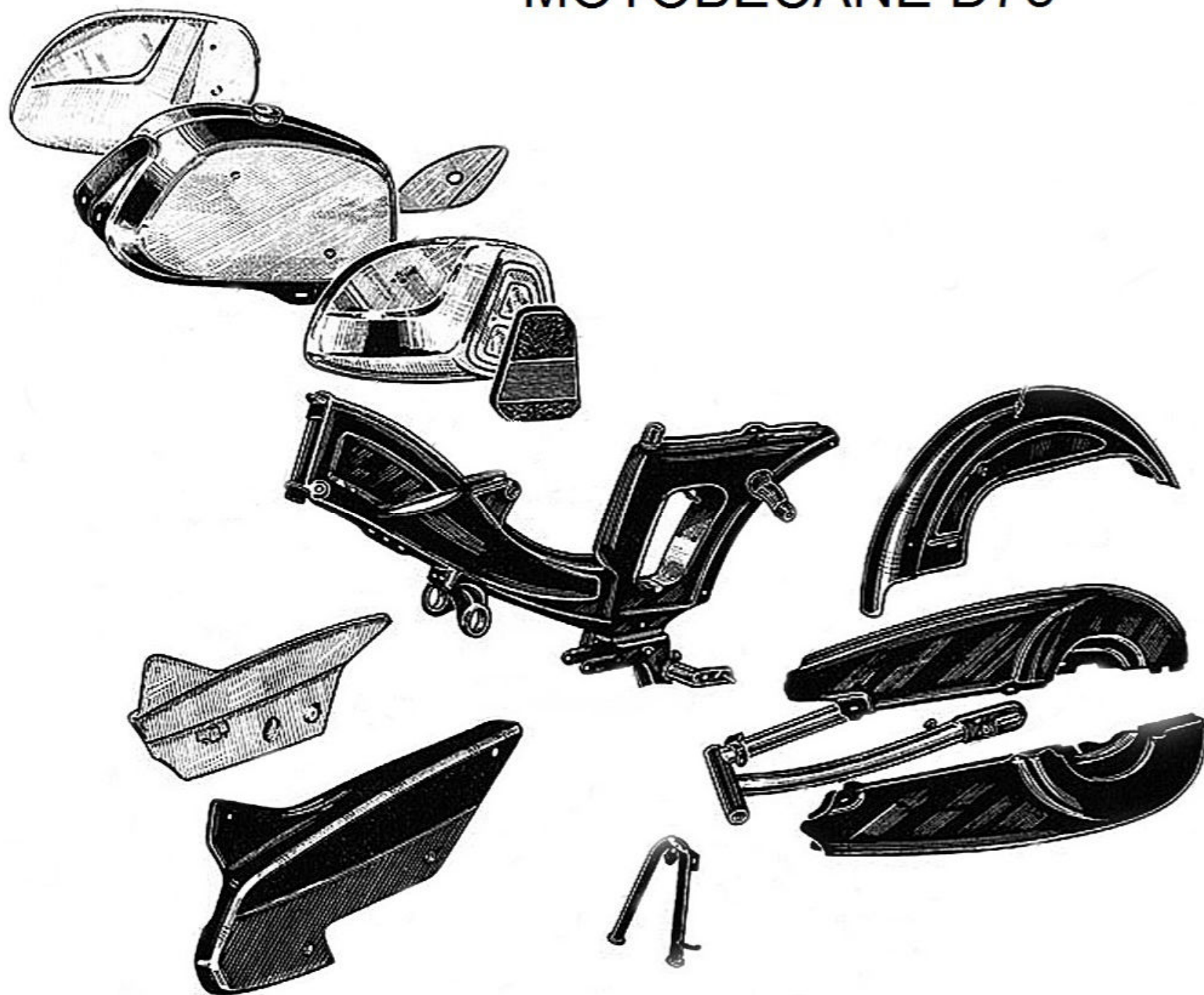

# CADRE - BRAS OSCILLANT - BÉQUILLE

50EW (79 Z)

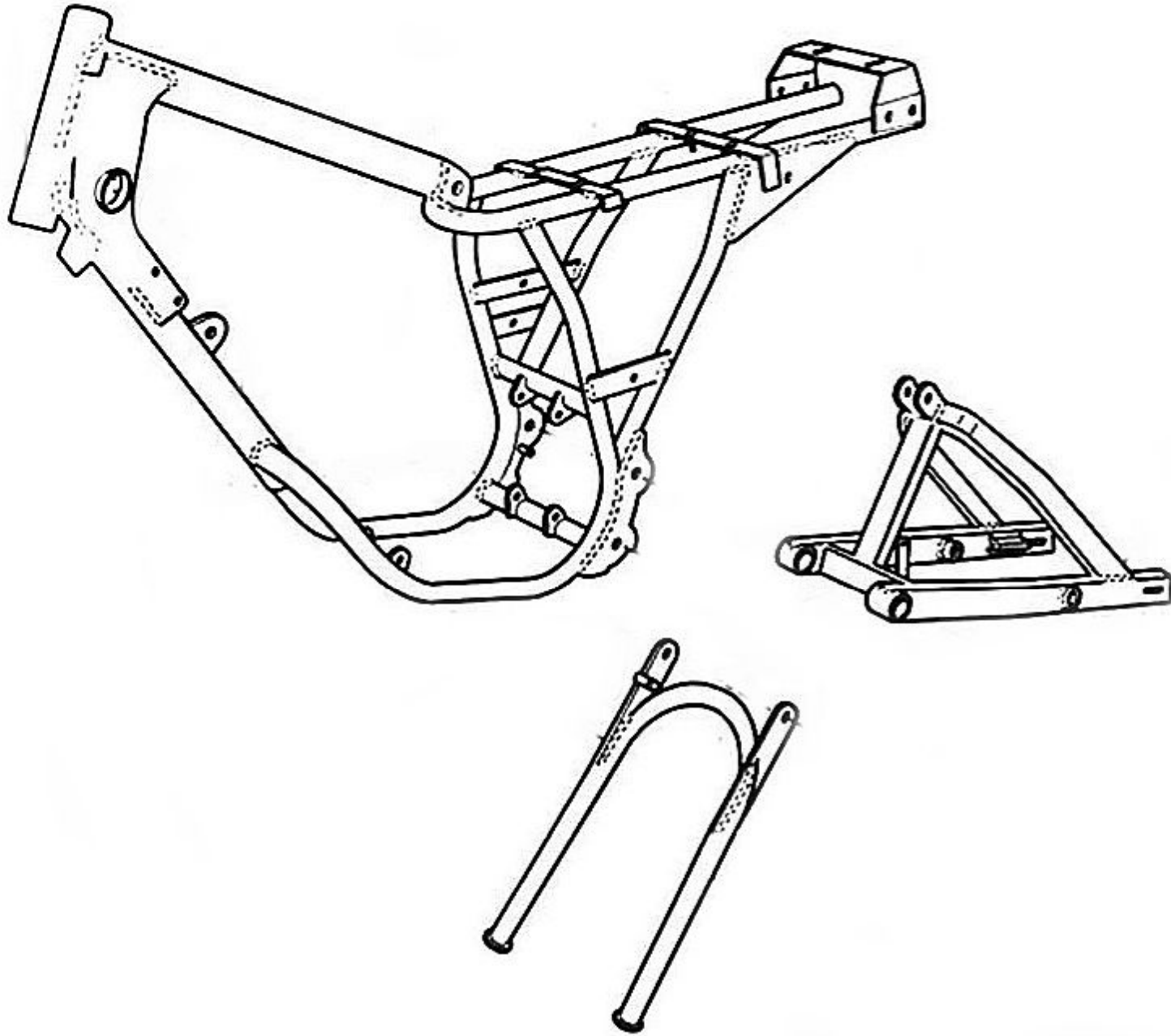

CADRE - BRAS OSCILLANT - BEQUILLE - TENDEUR  
FX 50

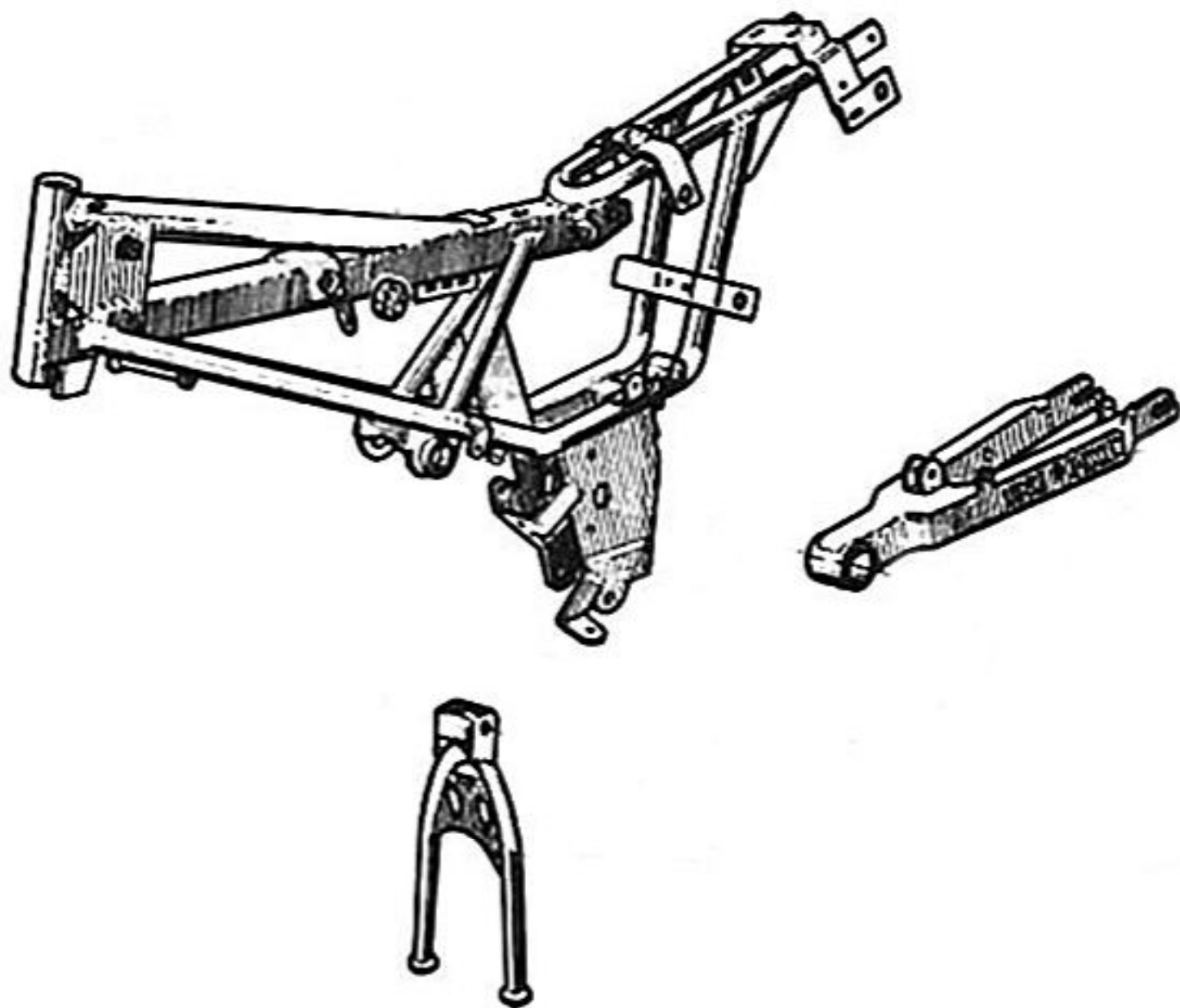

# SÉRIE G 50 - H 50

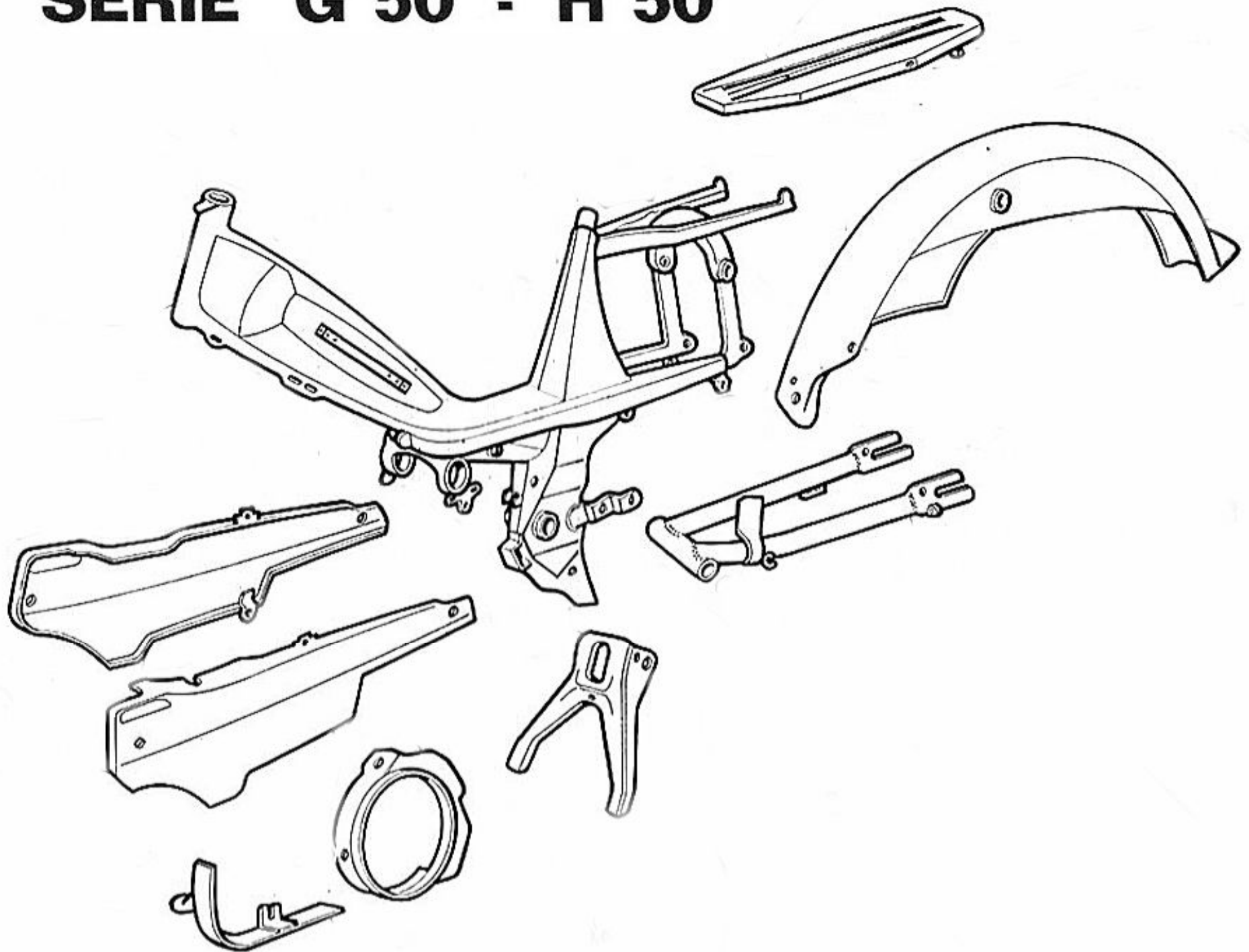

H 40 S - H 40 L - H 40 TS - H 40 TL - H 40 TLC

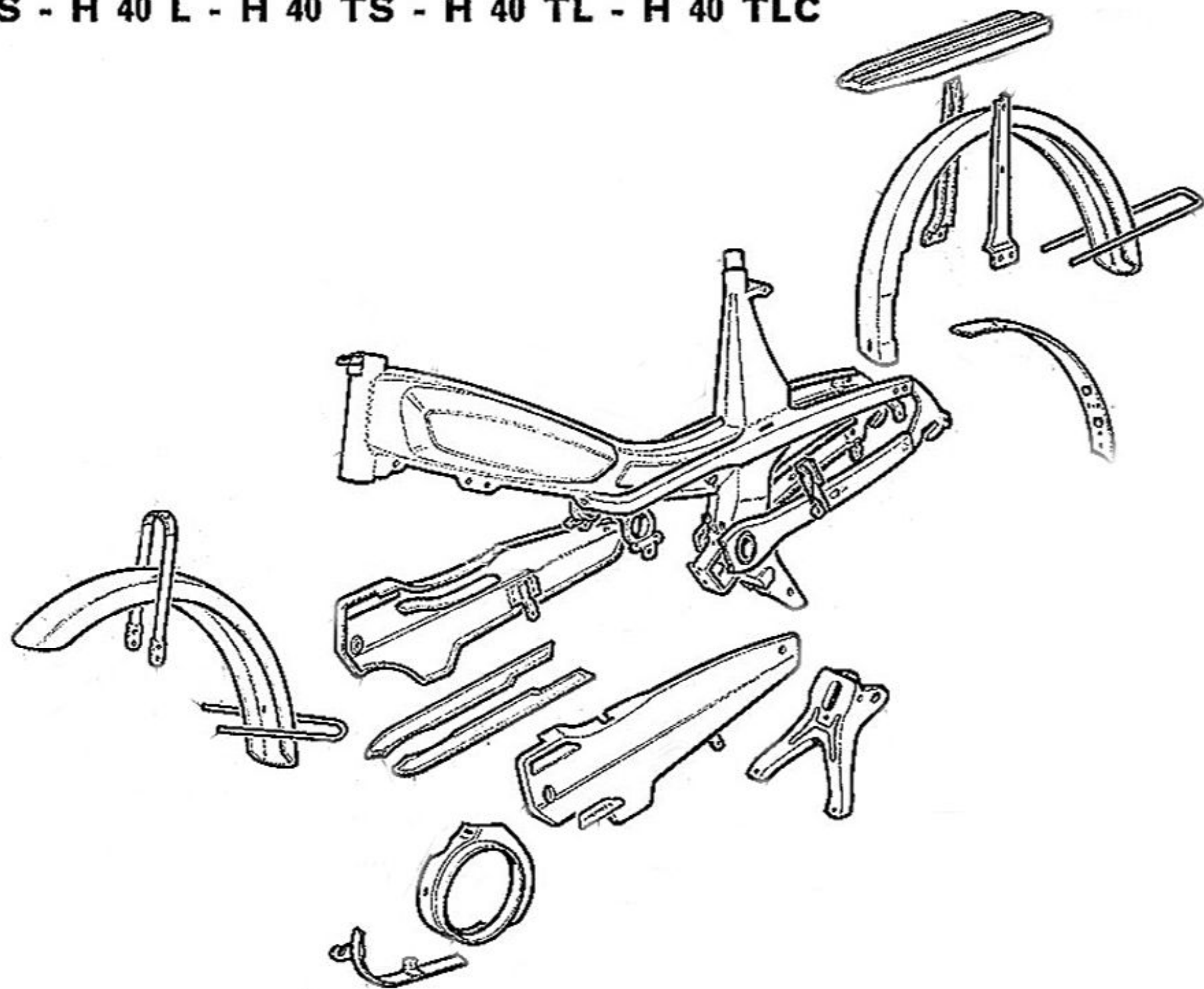

# TYPES L 99 e - L 75 N

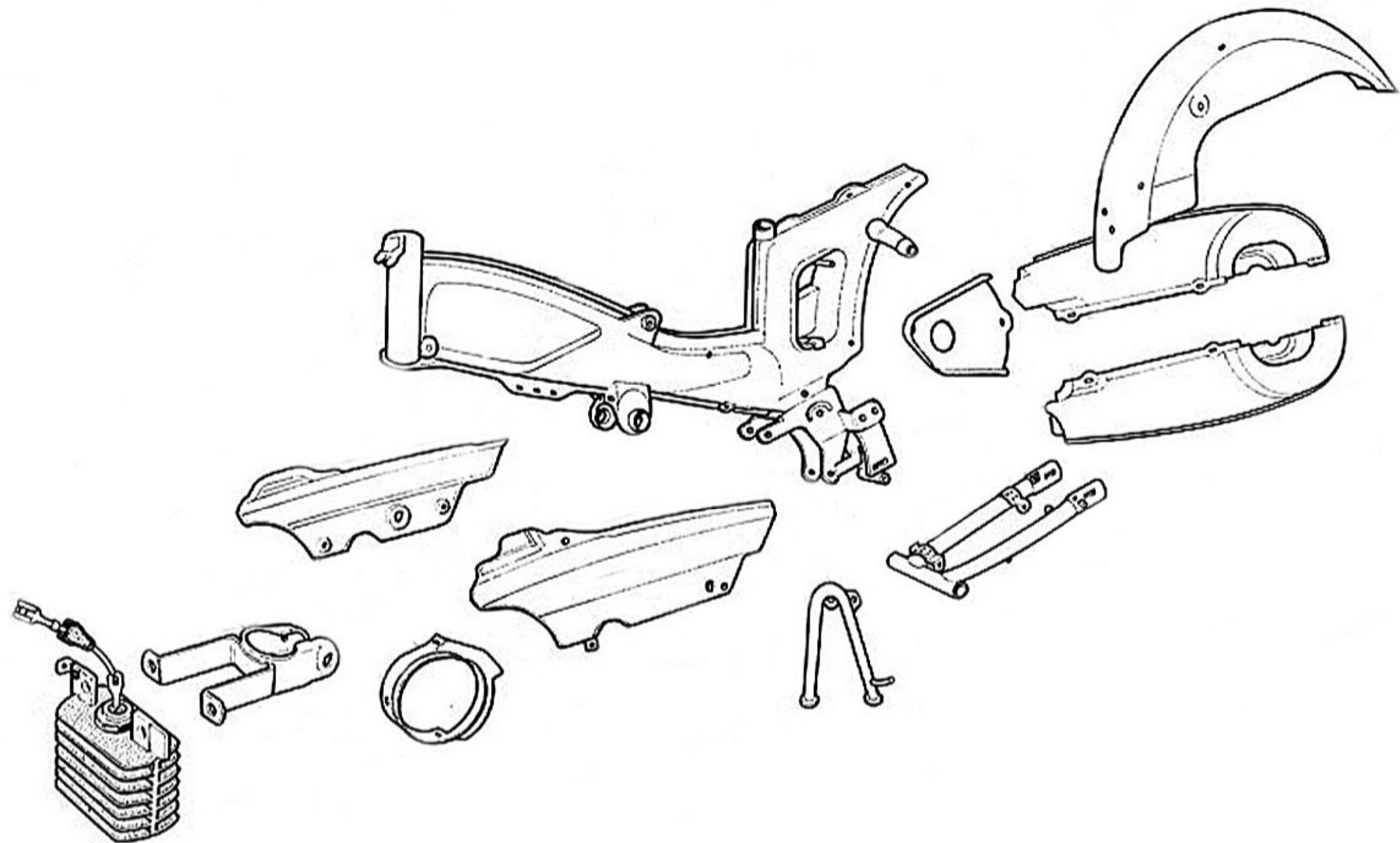



# MOBYLETTE type M7 M7 ranger

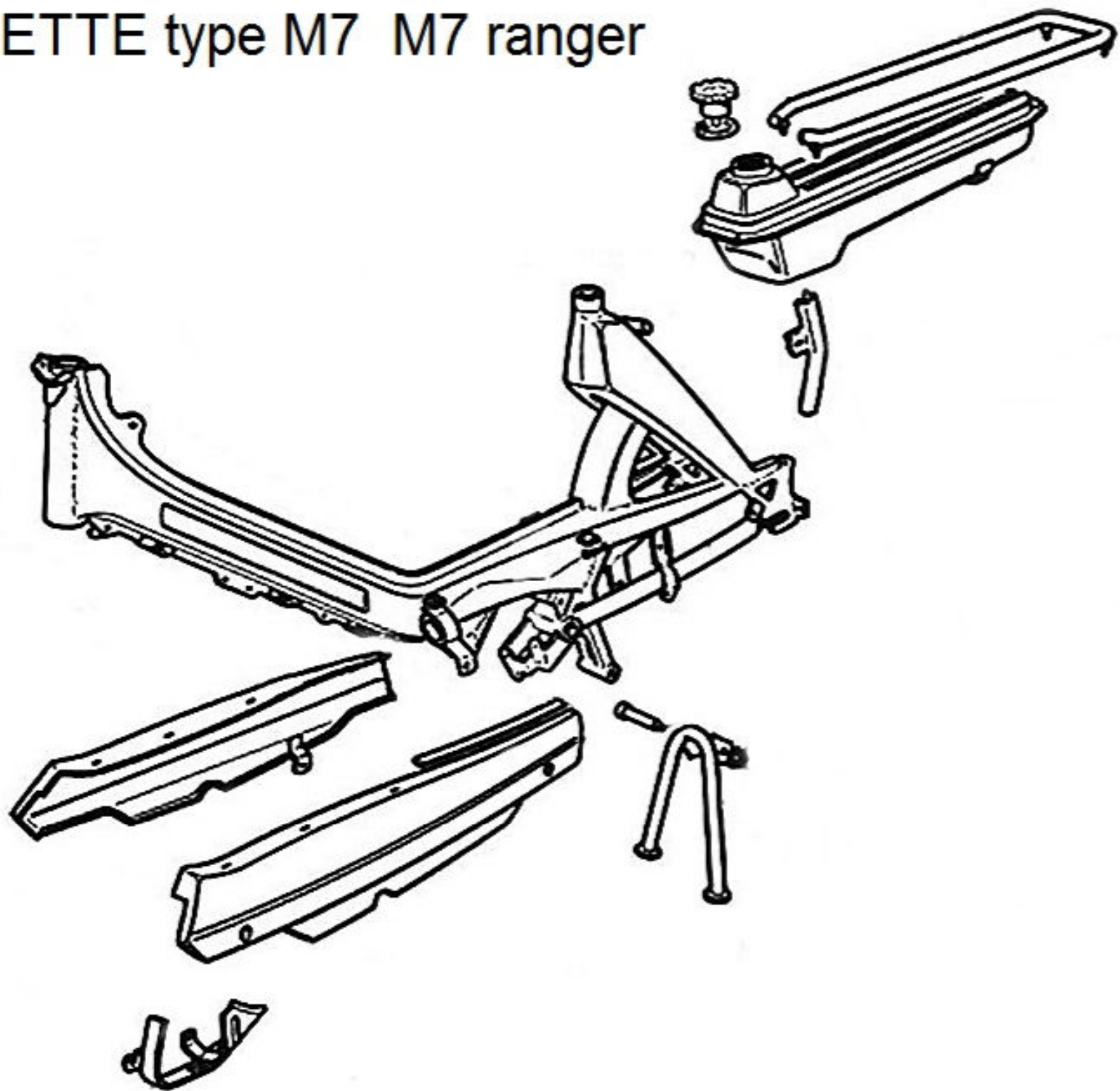

MOBYLETTE type M7 Spécial SL et SR

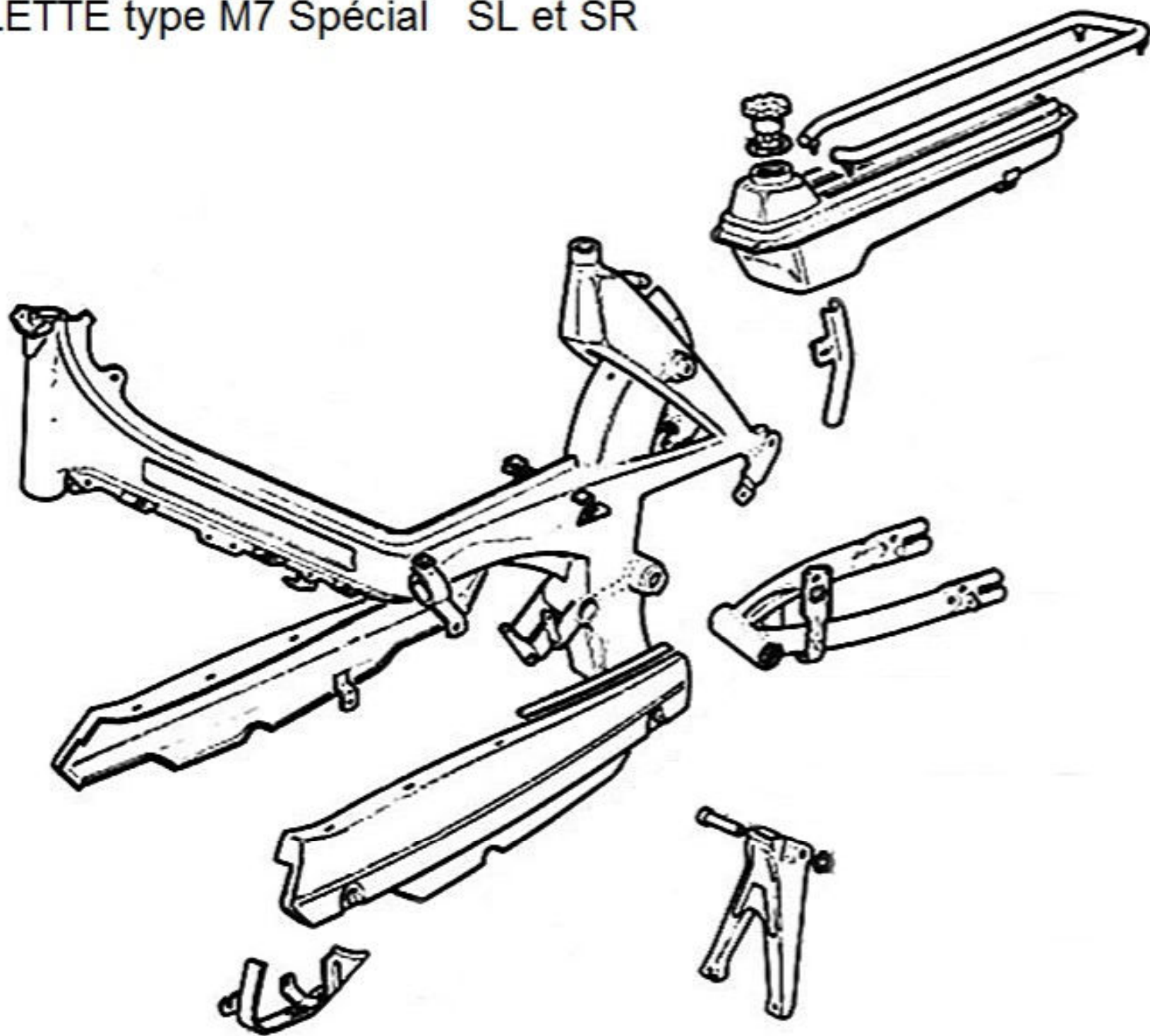

M11

# CADRE - BRAS OSCILLANT - BÉQUILLE

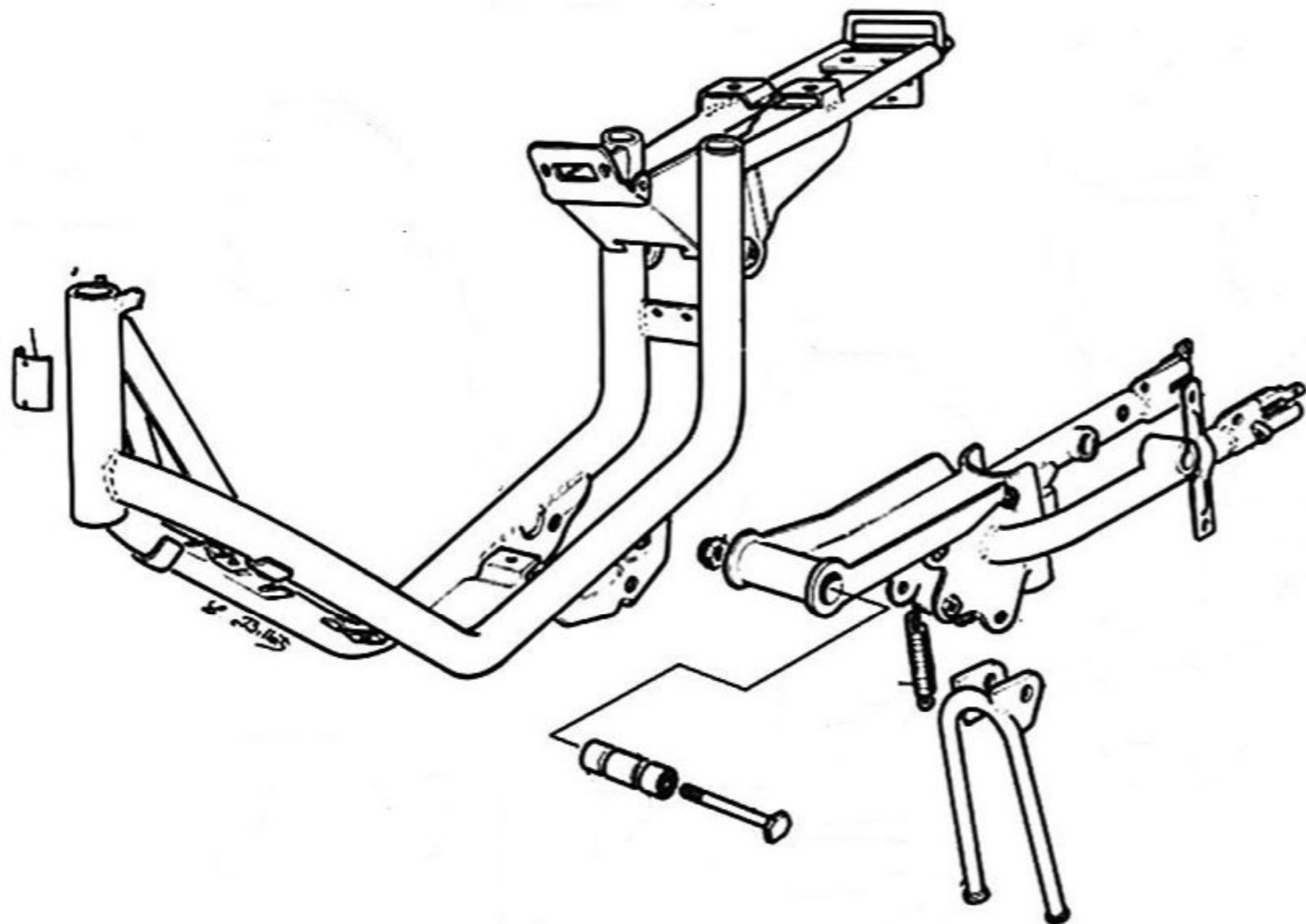

# CADRE - BRAS OSCILLANT - BÉQUILLE

M16 VS - VLC avec boîte relais

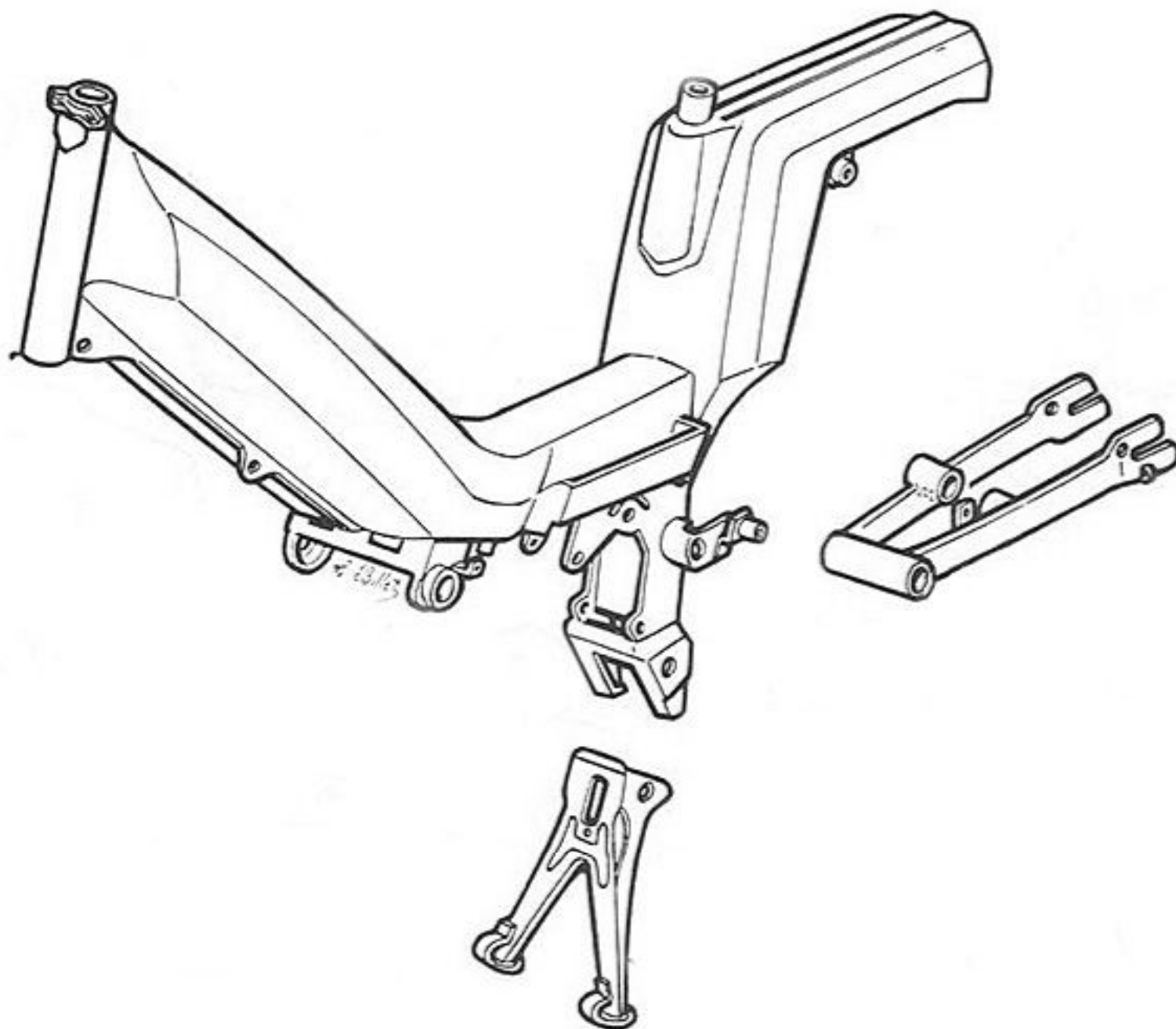

# CADRE - BRAS OSCILLANT - BÉQUILLE

M16 VS - VLC sans boîte relais

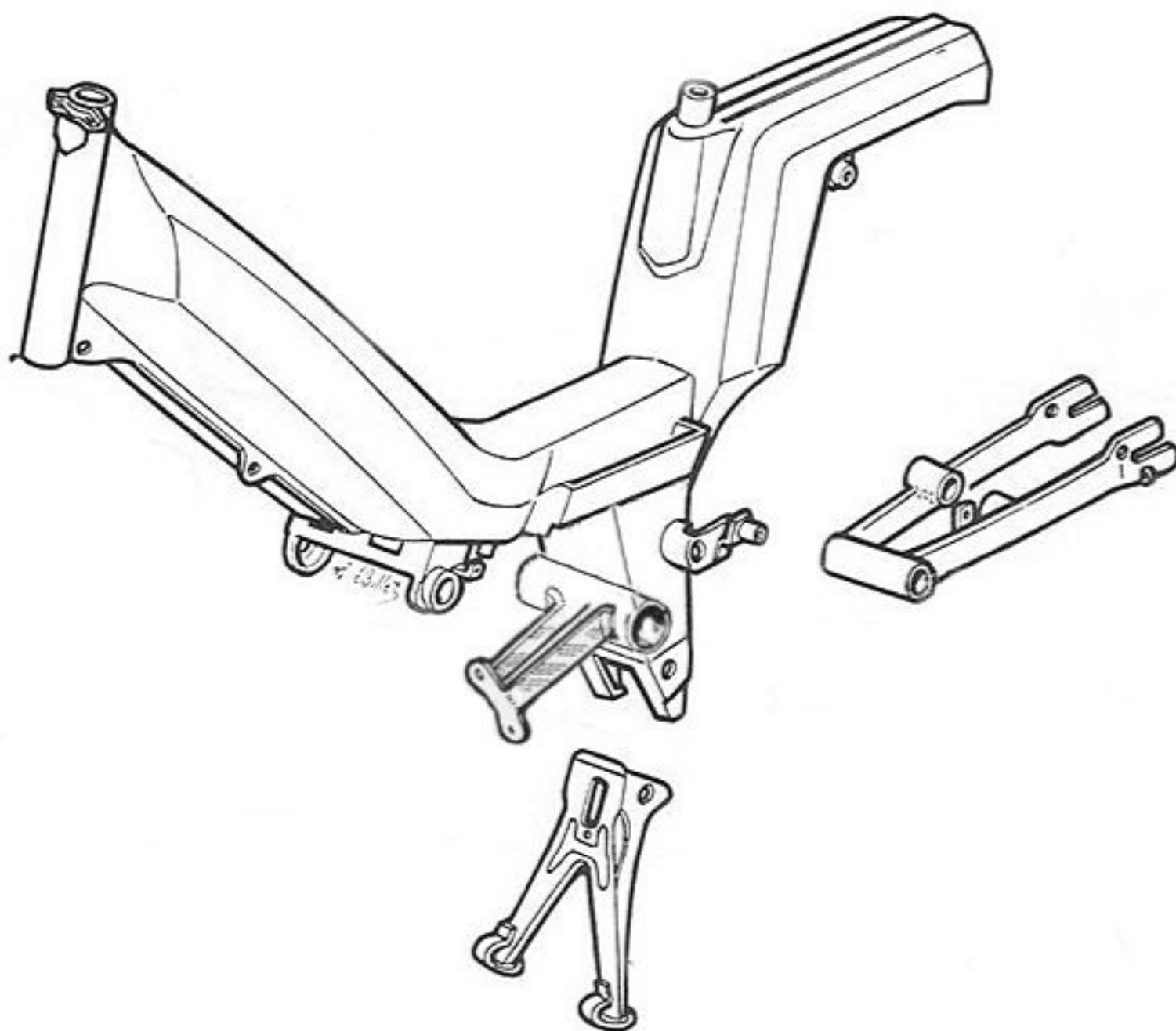

# PARTIE CYCLE

M 50 EV

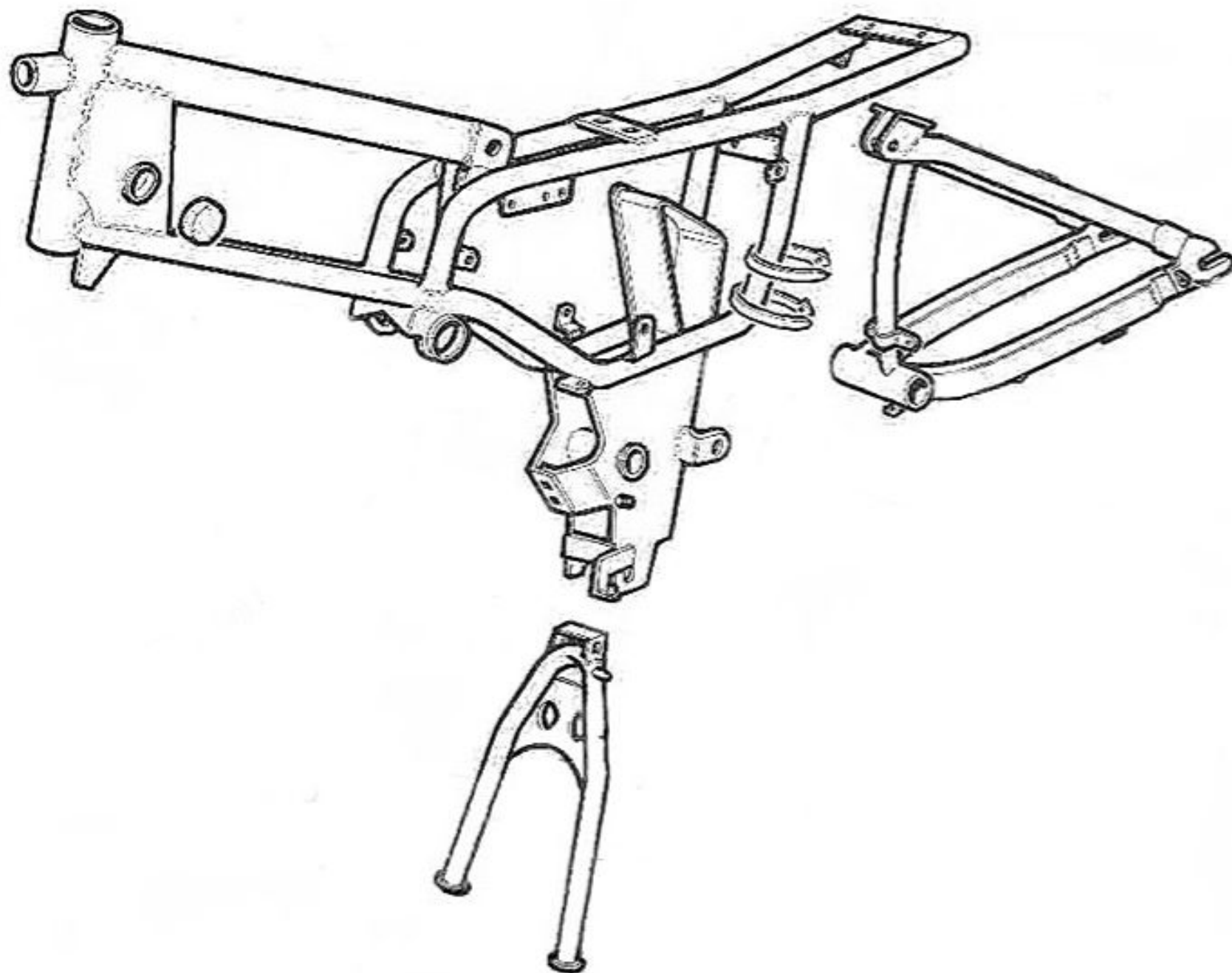

80 ENDURO  
**CADRE - BRAS OSCILLANT -**

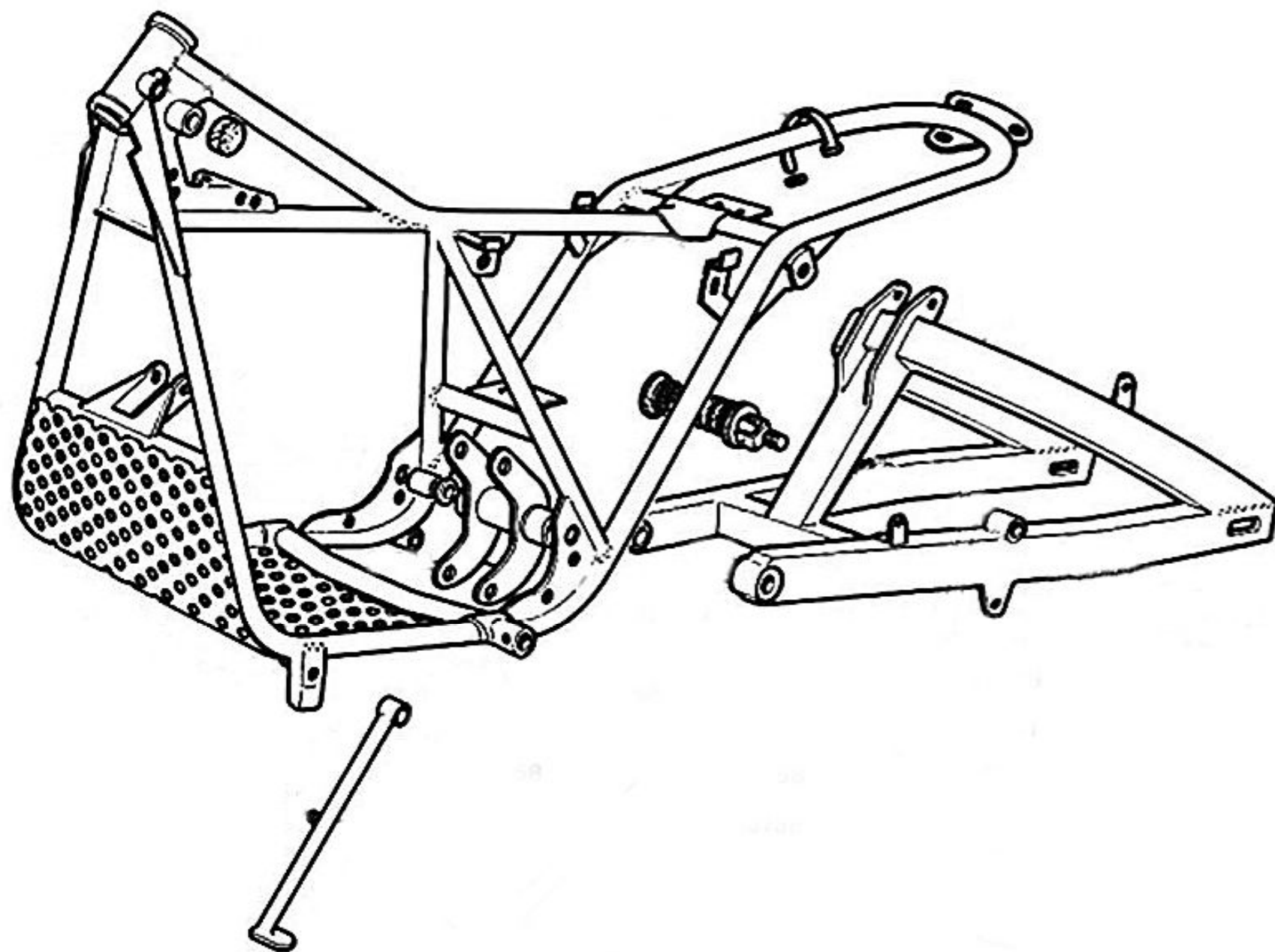

# MOBYLETTE

Type SP 93





**MOBYLETTE**

**Type SP 94 TT**

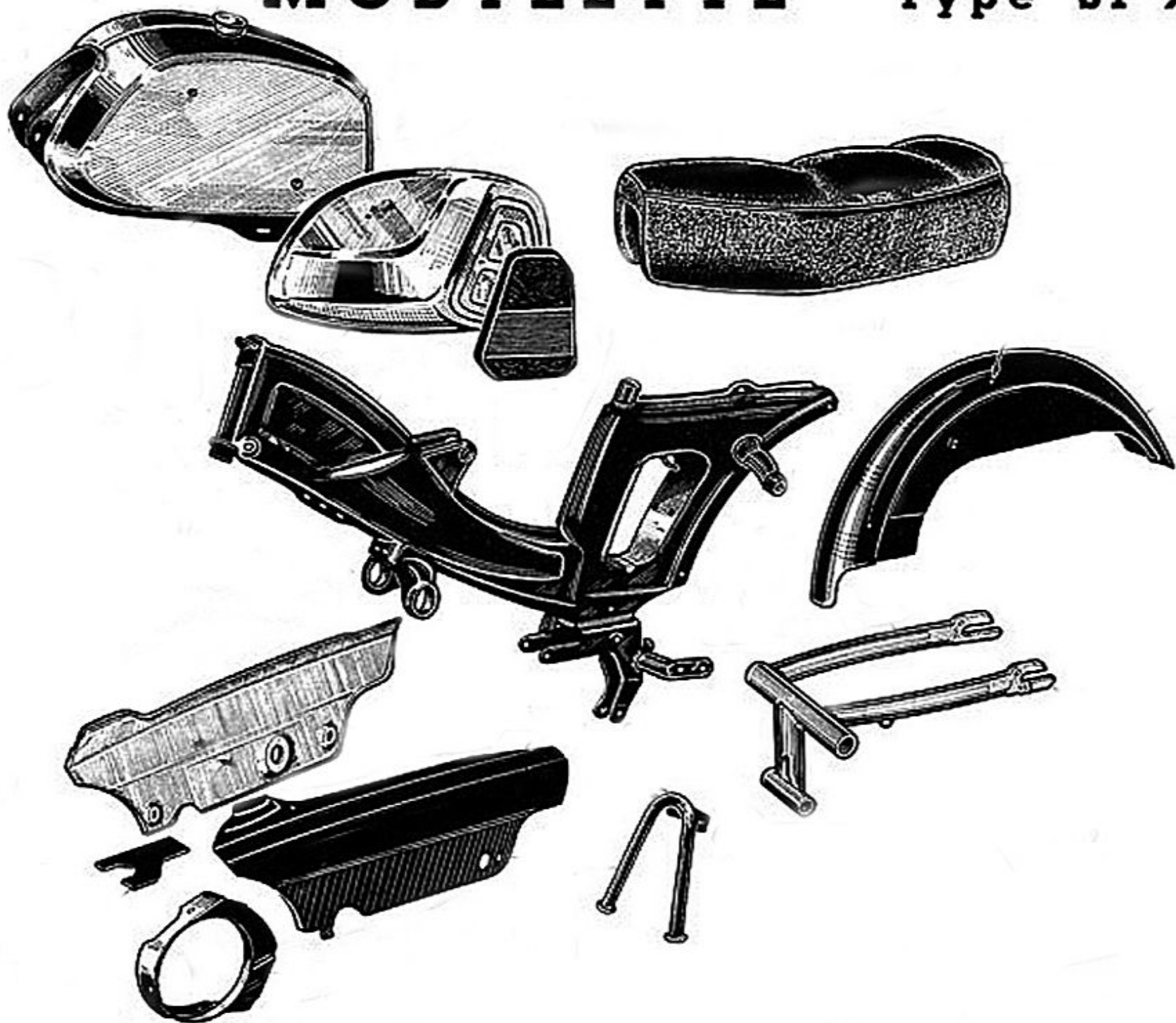

SP 98 et D 98 SP ou C 98 SP

PARTIE CYCLE

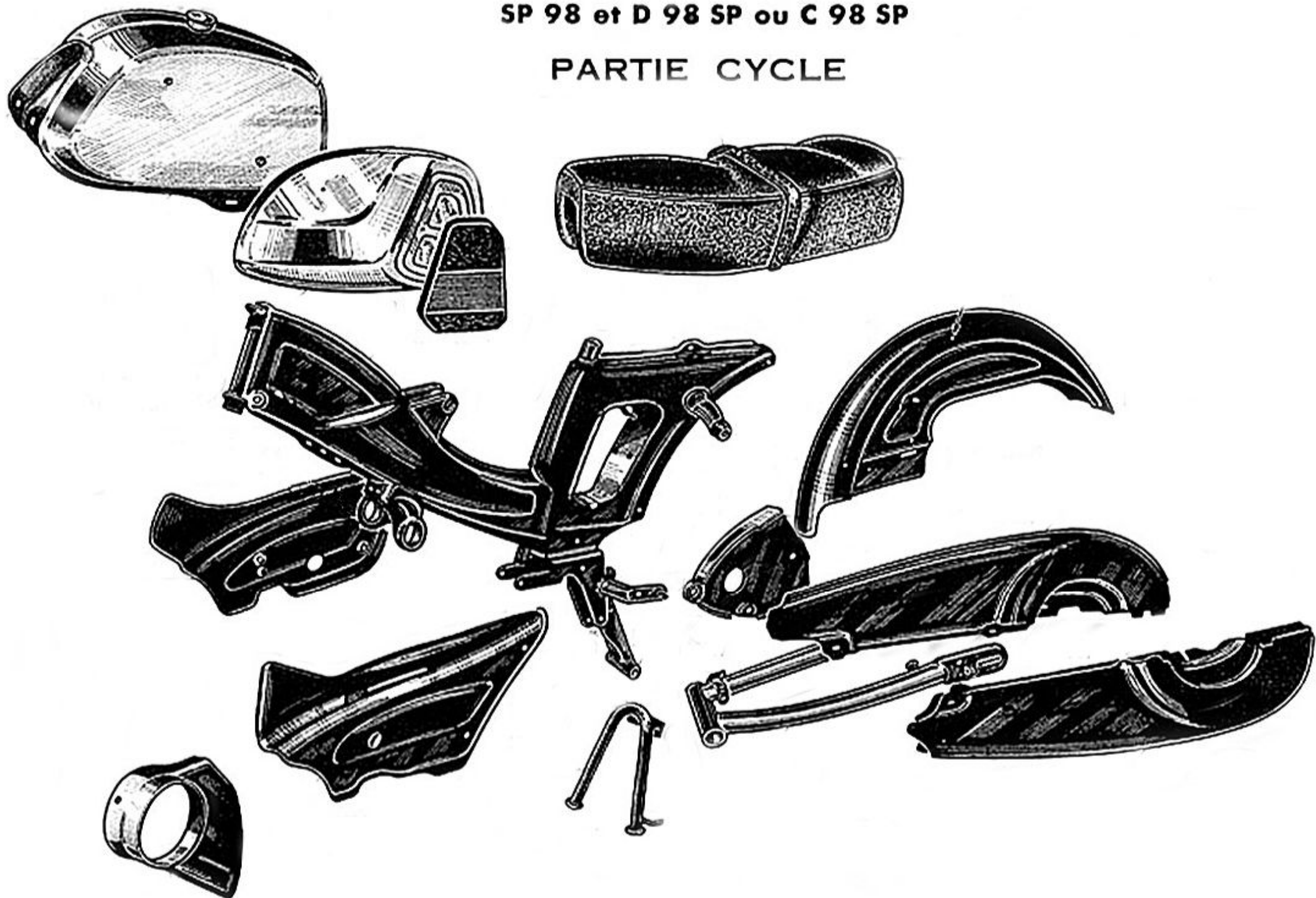

# TYPE "SPECIALE 50" version 1 1961

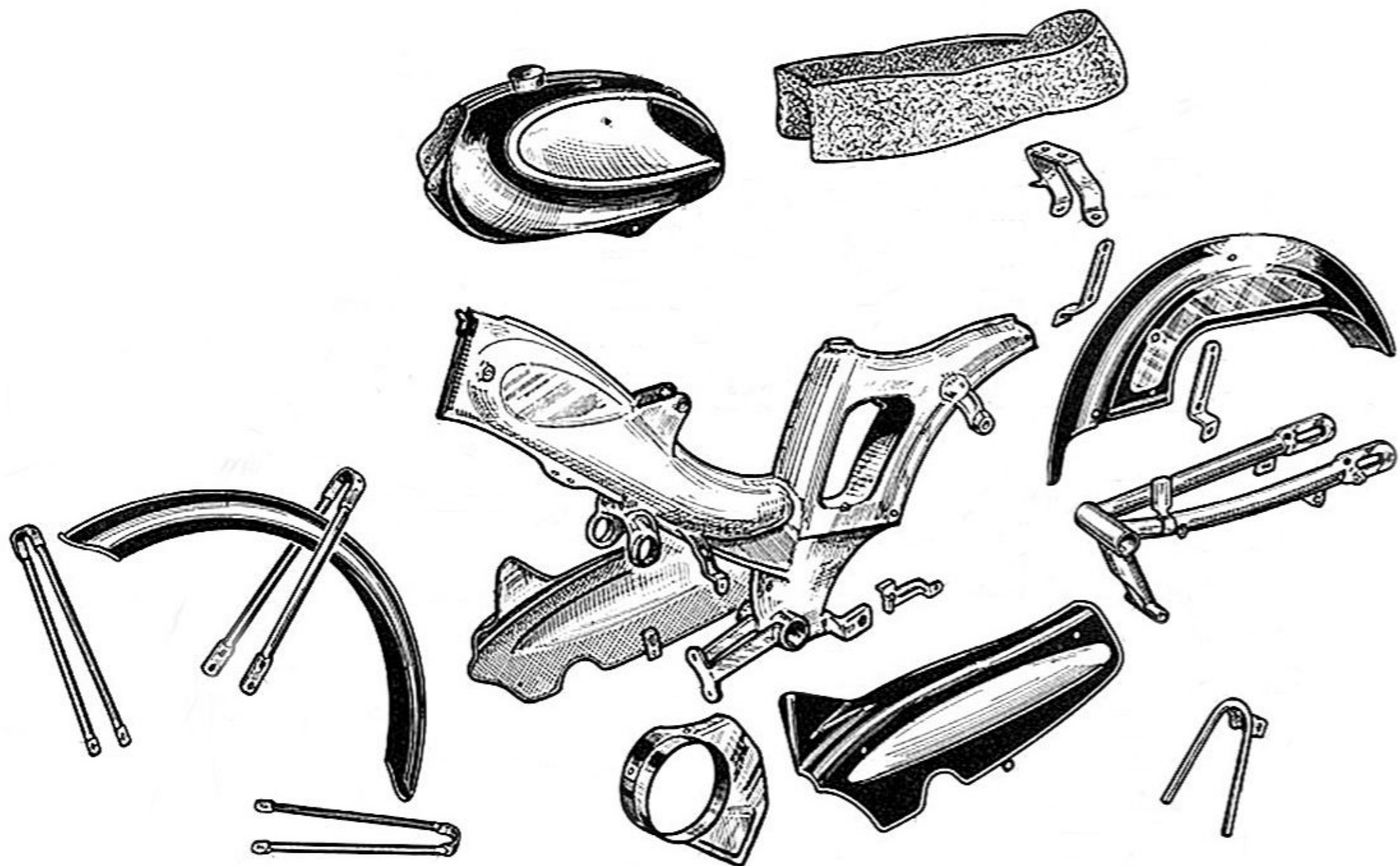

# PARTIE CYCLE SP50\_SPTT

SPTT

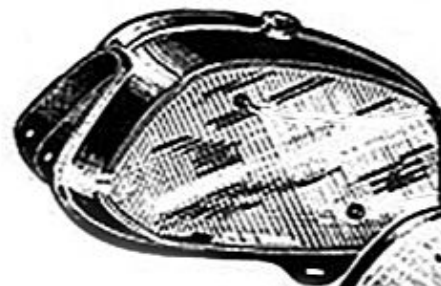
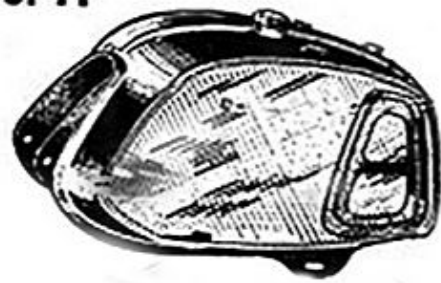

SP 50

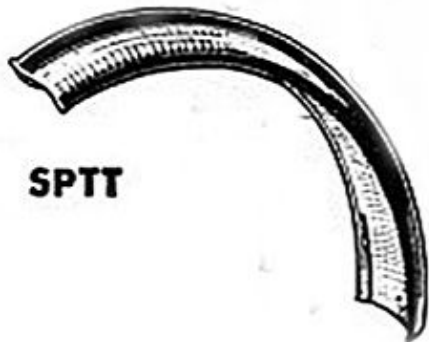

SPTT

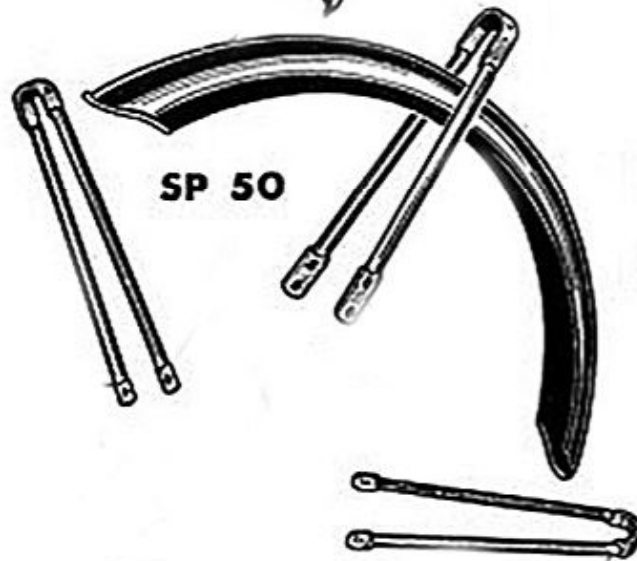
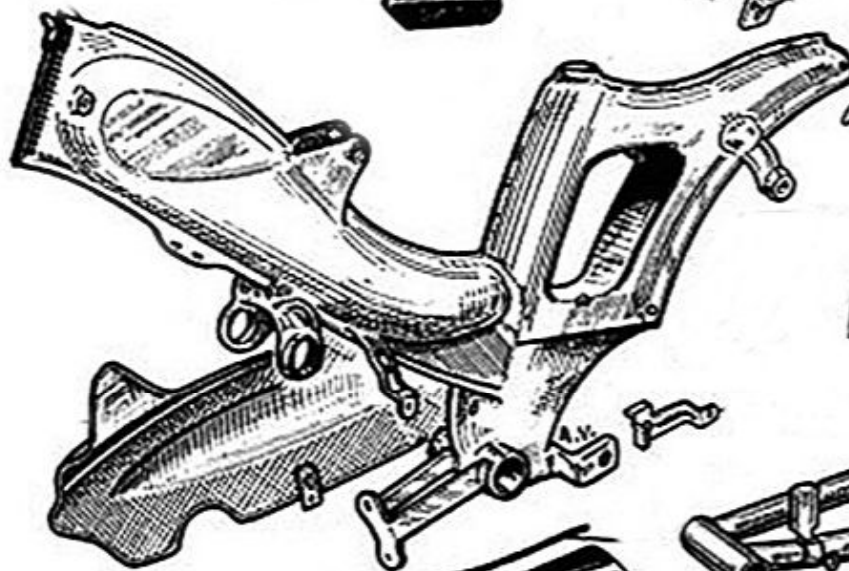

SP 50

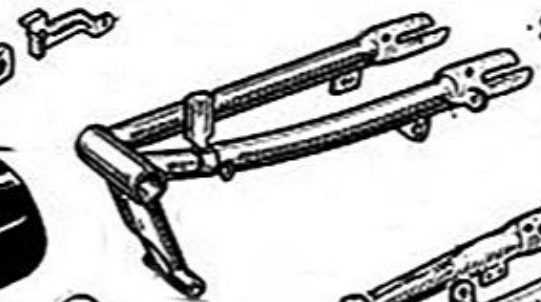

SP 50

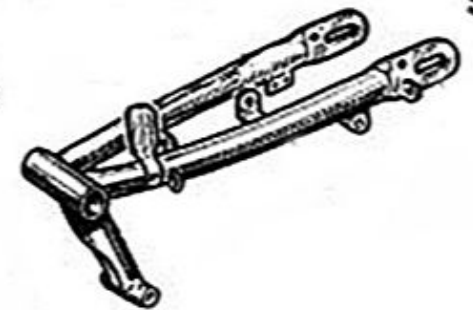

SPTT



**MOBYLETTE**

**Type SPR**

1962

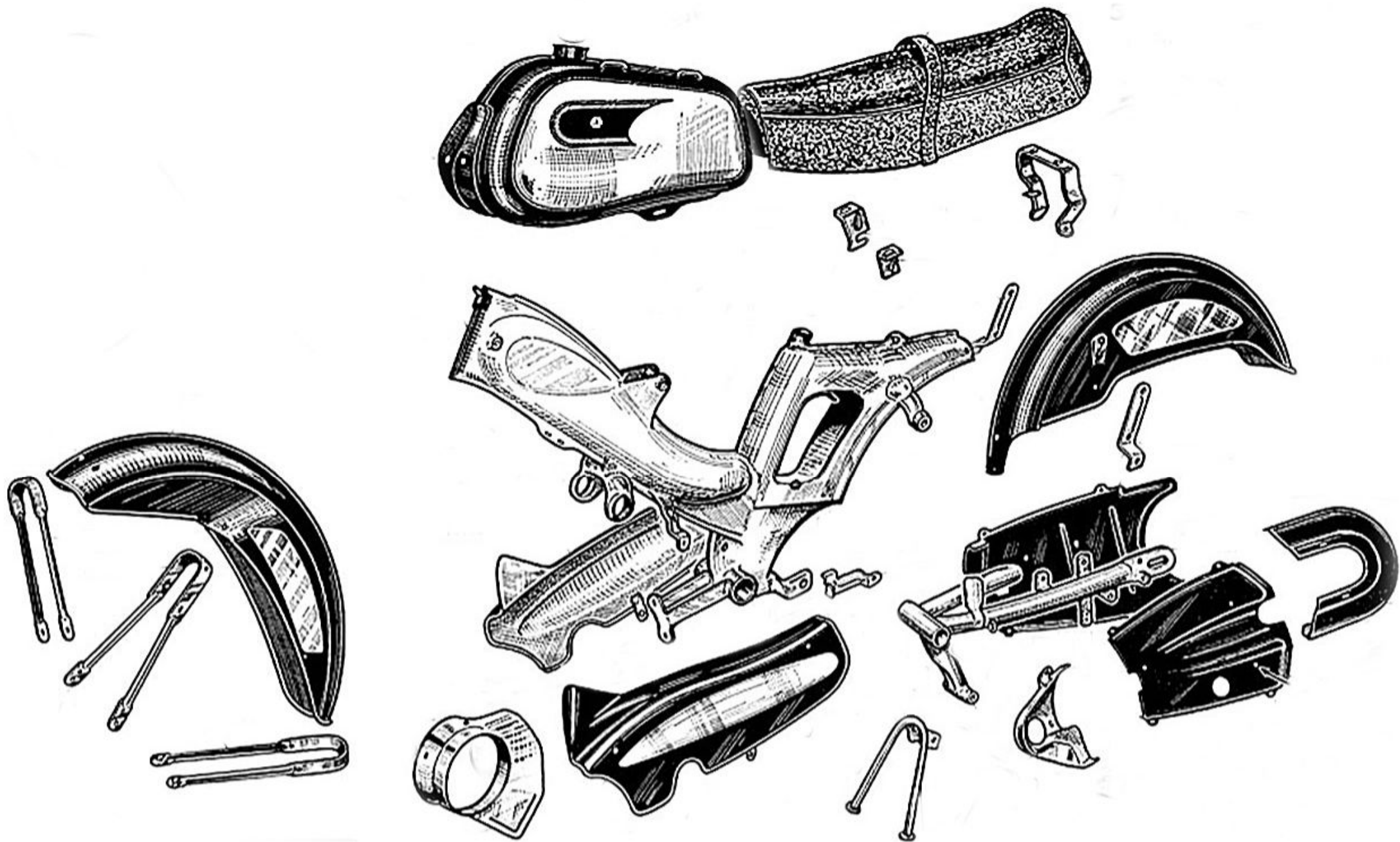

# MOBYLETTE

Type SPR version4 1966

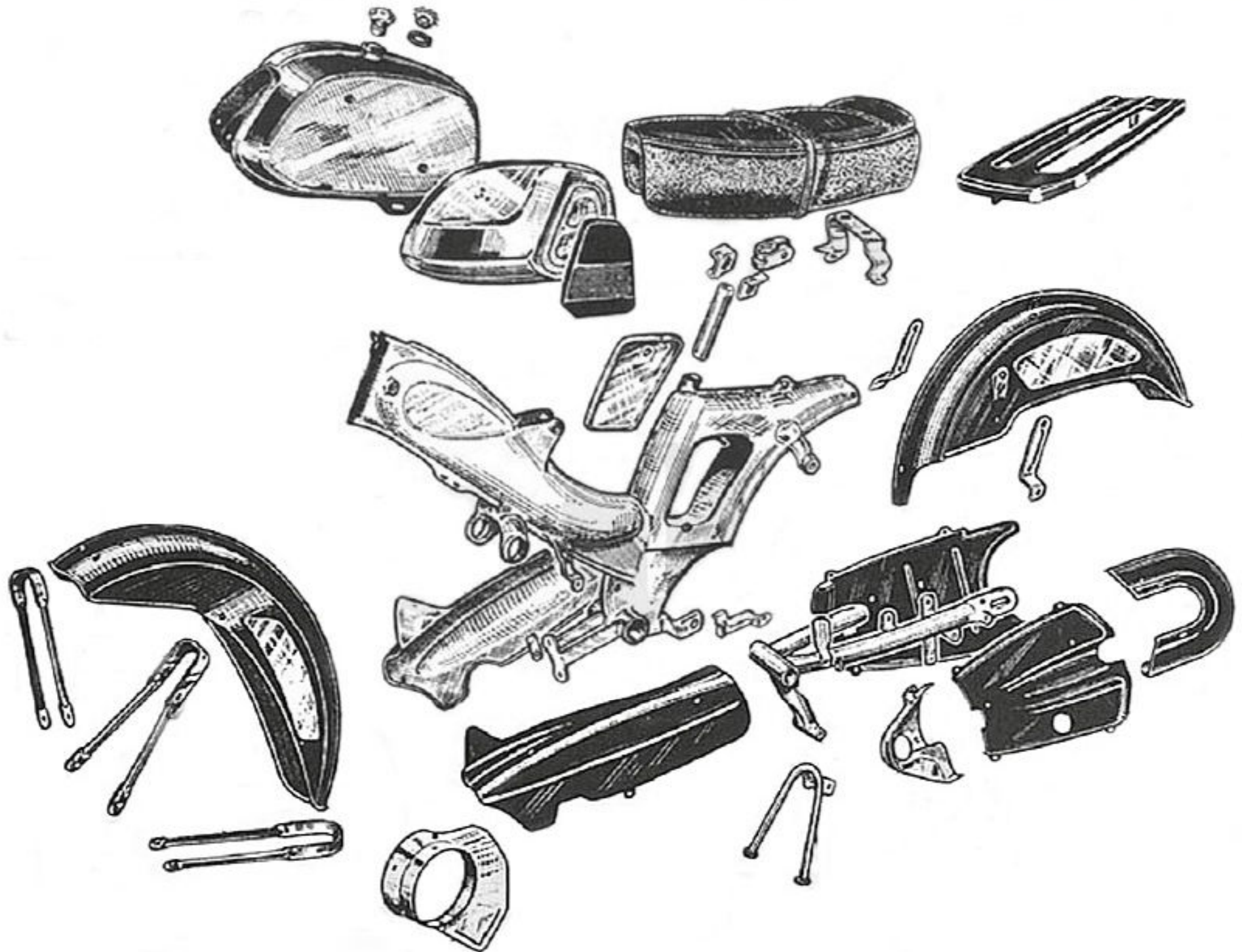

# Types X1 - X1L

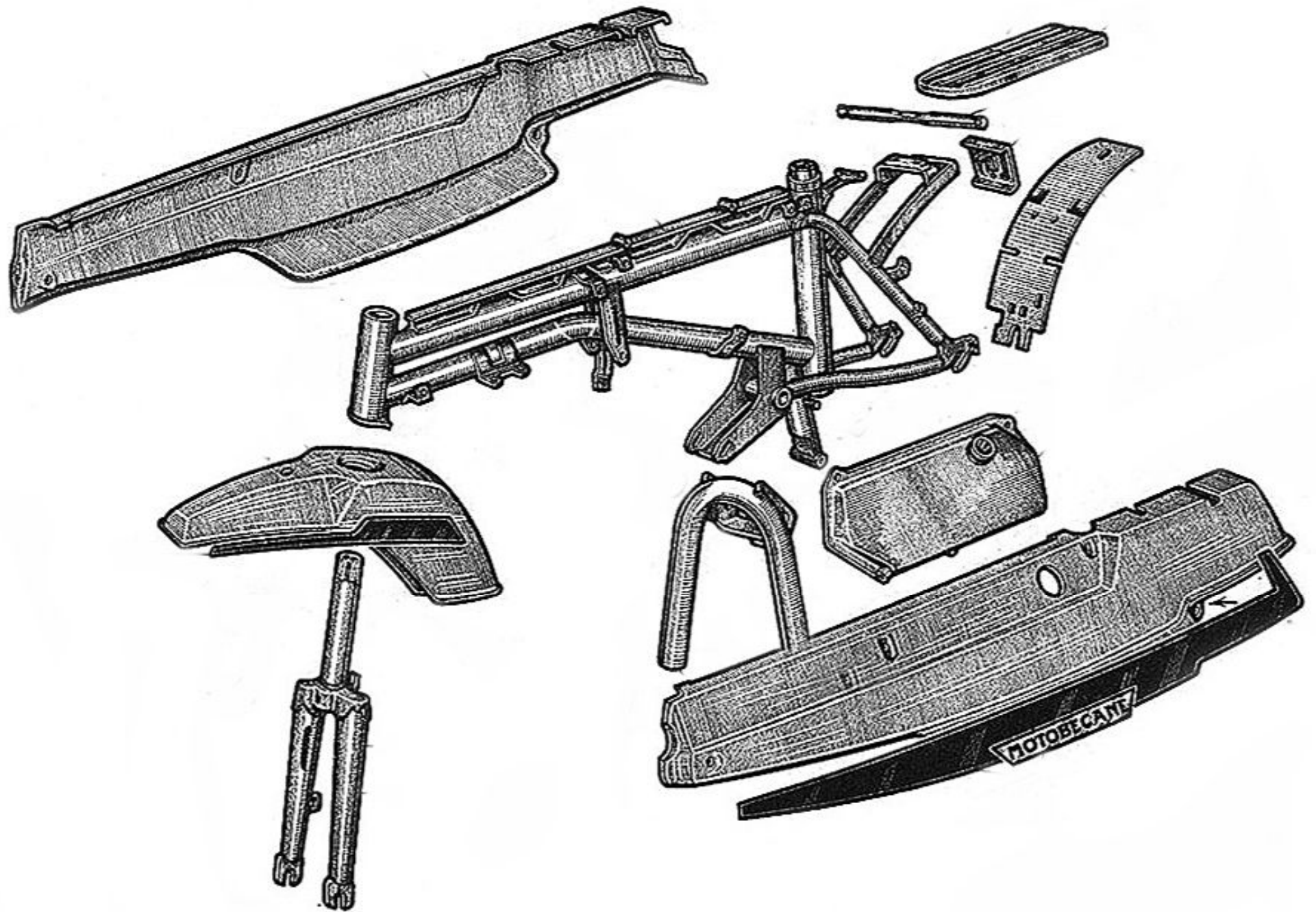

# SÉRIE X 7

