

harman/kardon

Service Manual

# AVR 160/230

5 x 40W 5.1 CHANNEL A/V RECEIVER



## CONTENTS

ESD WARNING	2	EXPLODED VIEW AND PARTS	12
FRONT AND REAR PANELS	3	ELECTRICAL PARTS LIST	13
REMOTE CONTROL	5	SEMICONDUCTOR PINOUTS	41
TROUBLESHOOTING GUIDE	8	PCB DRAWINGS	97
PROCESSOR RESET	8	BLOCK DIAGRAM	104
TECHNICAL SPECIFICATIONS	9	WIRING DIAGRAM	105
PACKAGE LISTS AND PARTS	10	AMP BIAS ADJUSTMENT	106
DISASSEMBLY	11	SCHEMATIC DIAGRAMS	107-116

Released EU2010

Harman Consumer Group, Inc.  
8500 Balboa Boulevard  
Northridge, California 91329

Rev 0, 05/2010

## ELECTROSTATICALLY SENSITIVE (ES) DEVICES

Some semiconductor (solid state) devices can be damaged easily by static electricity. Such components commonly are called Electrostatically Sensitive (ES) Devices. Examples of typical ES devices are integrated circuits and some field effect transistors and semiconductor "chip" components.

The following techniques should be used to help reduce the incidence of component damage caused by static electricity.



1. Immediately before handling any semiconductor component or semiconductor-equipped assembly, drain off any electrostatic charge on your body by touching a known earth ground. Alternatively, obtain and wear a commercially available discharging wrist strap device, which should be removed for potential shock reasons prior to applying power to the unit under test.
2. After removing an electrical assembly equipped with ES devices, place the assembly on a conductive surface such as aluminum foil, to prevent electrostatic charge build-up or exposure of the assembly.
3. Use only a grounded-tip soldering iron to solder or unsolder ES devices.
4. Use only an anti-static solder removal device. Some solder removal devices not classified as "anti-static" can generate electrical charges sufficient to damage ES devices.
5. Do not use freon-propelled chemicals. These can generate electrical charge sufficient to damage ES devices.
6. Do not remove a replacement ES device from its protective package until immediately before you are ready to install it. (Most replacement ES devices are packaged with leads electrically shorted together by conductive foam, aluminum foil or comparable conductive material.)
7. Immediately before removing the protective material from the leads of a replacement ES device, touch the protective material to the chassis or circuit assembly into which the device will be installed.

**CAUTION** : Be sure no power is applied to the chassis or circuit, and observe all other safety precautions.

8. Minimize bodily motions when handling unpackaged replacement ES devices. (Otherwise harmless motion such as the brushing together of your clothes fabric or the lifting of your foot from a carpeted floor can generate static electricity sufficient to damage an ES devices.

## PRODUCT SAFETY NOTICE

Each precaution in this manual should be followed during servicing.

Components identified with the IEC symbol  in the parts list are of special significance to safety. When replacing a component identified with , use only the replacement parts designated, or parts with the same ratings or resistance, wattage, or voltage that are designated in the parts list in this manual. Leakage-current or resistance measurements must be made to determine that exposed parts are acceptably insulated from the supply circuit before returning the product to the customer.

# FRONT-PANEL CONTROLS

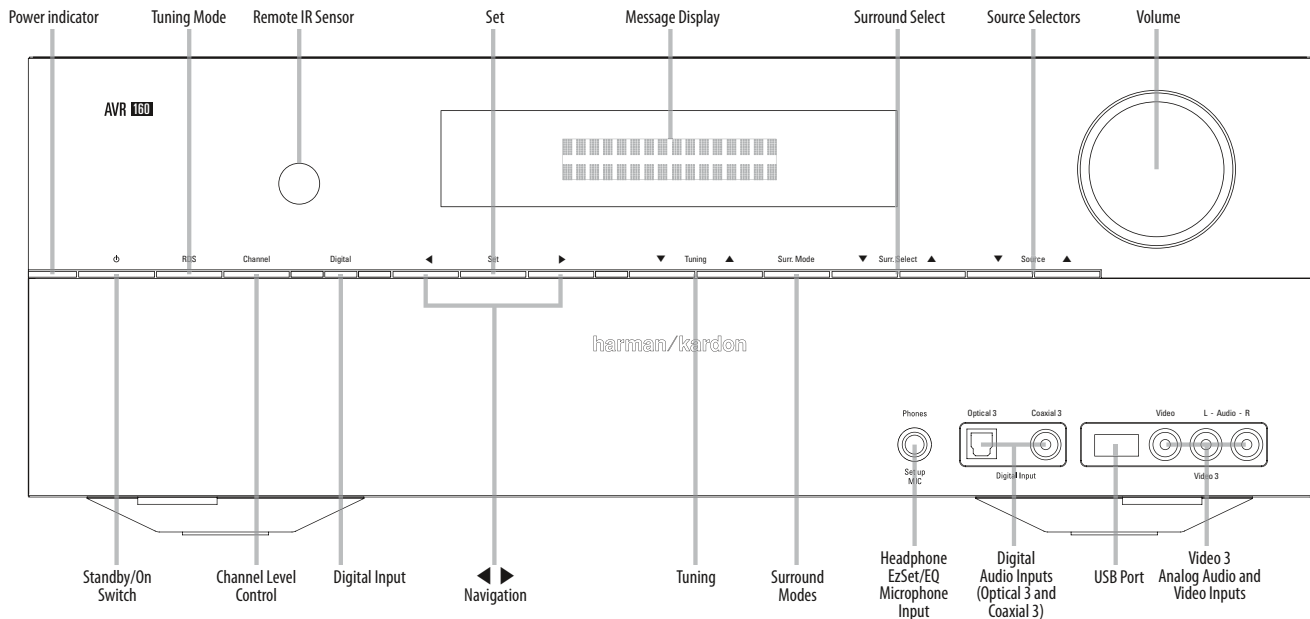

ENGLISH

**Power Indicator:** This LED has three possible modes:

- **Main Power Off:** When the AVR is unplugged or the Main Power Switch is off, this LED is off.
- **Standby:** Amber indicates that the AVR is ready to be turned on.
- **On:** When the AVR is turned on, this LED turns white.

**NOTE:** If the PROTECT message ever appears, turn off the AVR and unplug it. Check all speaker wires for a possible short. If none is found, bring the unit to an authorized Harman Kardon service center for inspection and repair before using it again.

**Standby/On Switch:** This electrical switch turns the receiver on, or places it in Standby mode for quick turn-on.

**RDS:** Activates RDS functions for FM Radio

**Channel Level Control:** Press this button to adjust the output level for any amplifier channel. It may be necessary to raise or lower the level of a specific channel to compensate for the placement of the relevant speaker in the room in relation to the listening position; e.g., the center channel speaker is further away from the listening position than the front left and right speakers, so that the dialogue is too soft to hear clearly.

To adjust the level of a channel, press this button once. If the desired channel is not displayed on screen and in the front-panel Message Display, use the Tuning Buttons to scroll to it. When the desired channel appears, use the ◀ ▶ Navigation Buttons to change the level.

It is recommended that you avoid changing the channel levels after you have run the EzSet/EQ setup procedure described in the Initial Setup section, which properly adjusts all channel levels. See the Advanced Functions section for more information on manual speaker setup, including level adjustment.

**Remote IR Sensor:** This sensor receives infrared (IR) commands from the remote control. It is important to ensure that it is not blocked. If covering the sensor is unavoidable, use an optional Harman Kardon HE 1000, or other infrared receiver, connecting it to the Remote IR Input on the AVR 160's rear panel.

**Digital Input:** To change the audio input for the current source to one of the six digital audio inputs or the analog input for the source, press this button and use the ◀ ▶ Navigation Buttons to change the input. Although any digital audio input may be assigned to any source, the analog audio inputs are all permanently dedicated to the source with which they are labeled.

◀ ▶ **Navigation:** These buttons are used to navigate the AVR's menus.

**Set:** Press this button to select the currently highlighted item.

**Message Display:** Various messages appear in this two-line display in response to commands and changes in the incoming signal. In normal operation, the current source name appears on the upper line, while the surround mode is displayed on the lower line. When the on-screen display menu system (OSD) is in use, the current menu settings appear.

**Tuning:** Press these buttons to tune a radio station.

# REAR-PANEL CONNECTIONS

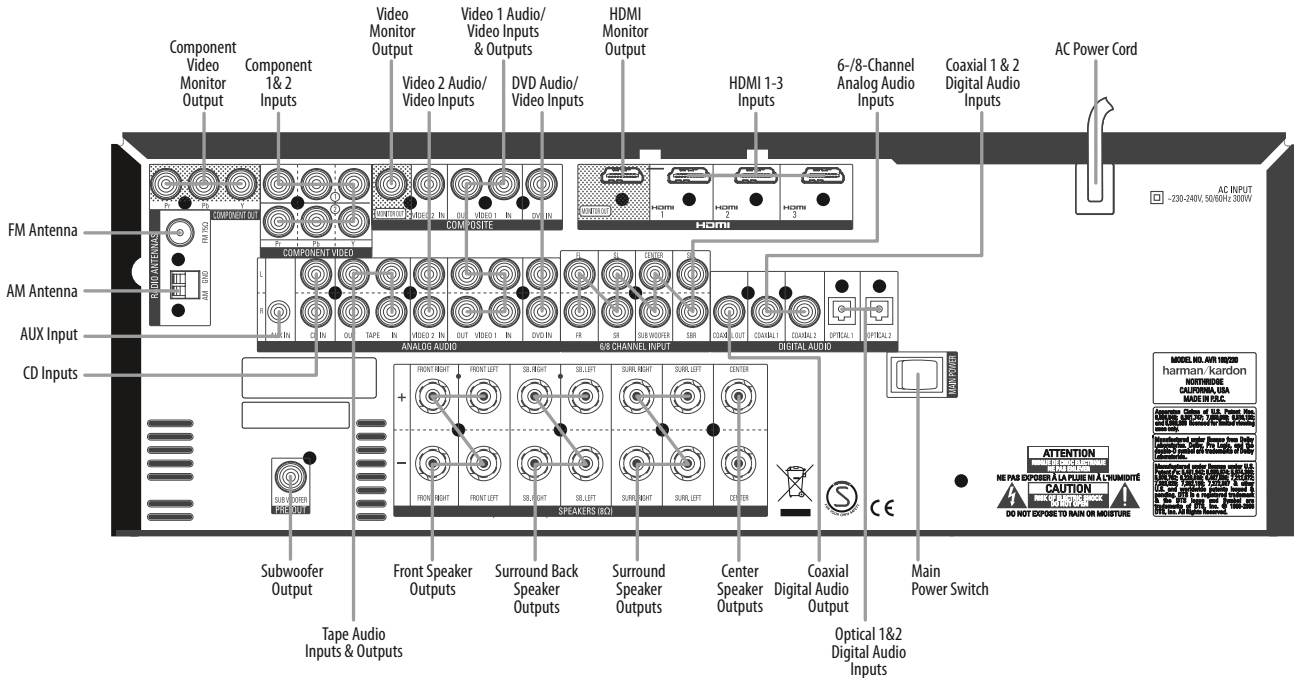

ENGLISH

**AM and FM Antenna Terminals:** Connect the included AM and FM antennas to their respective terminals for radio reception.

**Component Video Monitor Output:** If you are using one of the Component Video Inputs and your television or video display is component-video-capable, connect these jacks to the video display.

**NOTE:** Due to copy-protection restrictions, there is no output at the Component Video Monitor Outputs for copy-protected sources.

**Component Video 1&2 Inputs:** If a video source has analog component video (Y/Pb/Pr) capability, and if you are not using an HDMI connection, connect the component video outputs of the source to one of the sets of component video inputs. Do not make any other video connections to that source.

**NOTE:** AVR 160 does not transcode composite video source signals to the component video format.

**Video Monitor Output:** If any of your sources use composite video connections, connect this monitor output to the corresponding input on your video display. Composite video source signals are only available at this output.

**Video 1, Video 2 and DVD Audio/Video Inputs:** These jacks may be used to connect your video-capable source components (e.g., Blu-ray Disc™ player, DVD player, cable TV box) to the receiver.

**NOTE:** If a source is equipped with an HDMI output, it is preferable to connect it to one of the AVR's HDMI Inputs. If the source does not have an HDMI output, use its component or composite video output, and make a separate audio connection.

**Video 1 Audio/Video Outputs:** These jacks may be used to connect your DVR, VCR or another recorder.

**HDMI Inputs and Output:** HDMI (High-Definition Multimedia Interface) is a connection for transmitting digital audio and video signals between devices. Connect up to three HDMI-equipped source devices to the HDMI inputs using a single-cable connection.

When you connect the HDMI Output to your video display, the AVR 160 will automatically transcode component video source signals to the HDMI format, but they will be passed through at the original resolution and will not be scaled. The AVR's on-screen menus are visible when the HDMI Output is used, but only at 576i resolution. The main video source will not be visible.

**NOTES:** When connecting a DVI-equipped display to one of the HDMI Outputs:

- Use an HDMI-to-DVI adapter.
- Make sure the display is HDCP-compliant. If it isn't, do not connect it to an HDMI Output; use an analog video connection instead.
- Always make a separate audio connection.



# REMOTE CONTROL FUNCTIONS

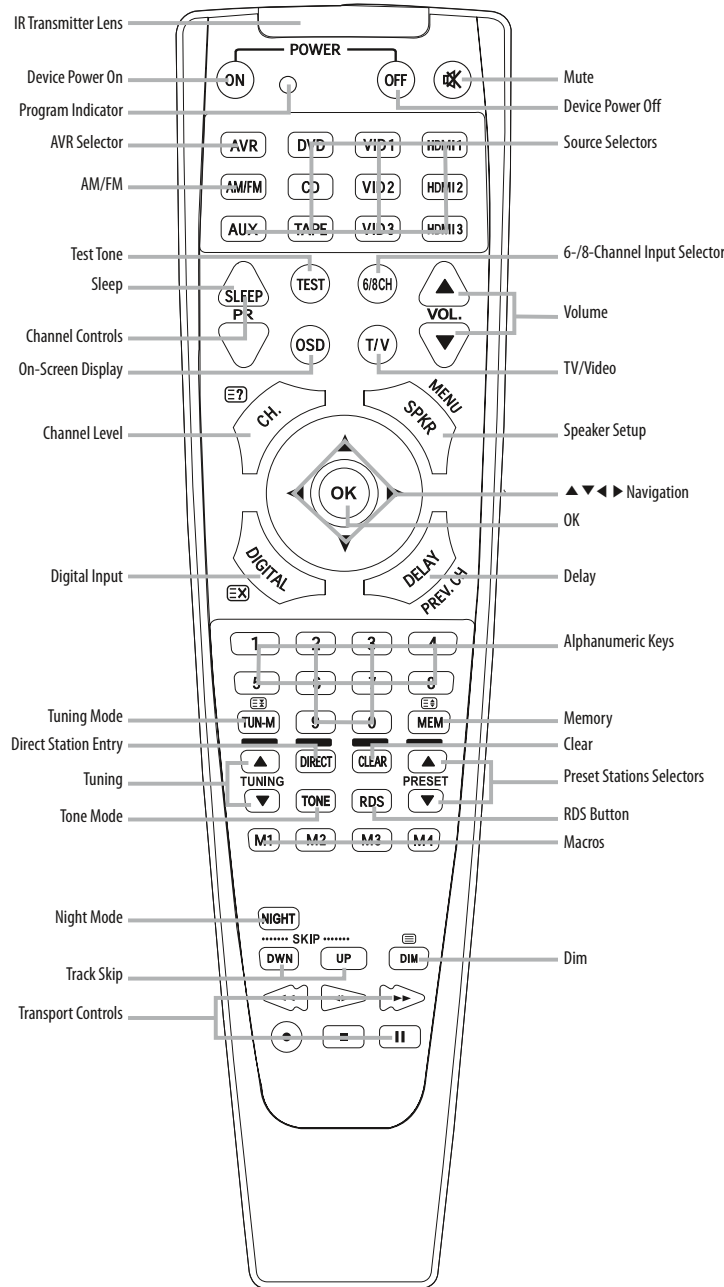

ENGLISH

The AVR 160 remote is capable of controlling up to 11 devices, including the AVR itself and a device connected to the Auxiliary Input. During the installation process, you may program the codes for each of your source components into the remote. Each time you wish to operate any component or the AVR, first press its Selector Button to change the device mode to the appropriate codes.

Each Source Selector has been preprogrammed to control certain types of components, with only the codes specific to each brand and model changing, depending on which product code is programmed. The device types programmed into each selector, except the HDMI selectors, may not be changed.

**DVD:** Controls Harman Kardon Blu-ray Disc players, and many brands of DVD players and recorders.

**CD:** Controls CD players and recorders.

**Tape:** Controls cassette decks.

**Video 1:** Controls VCRs, TiVo® devices and DVRs, and the Harman Kardon DMC 1000 digital media center.

**Video 2:** Controls cable and satellite television set-top boxes.

**Video 3:** Controls televisions and other video displays.

**HDMI 1:** Controls Harman Kardon Blu-ray Disc players, and many brands of DVD players and recorders.

# REMOTE CONTROL FUNCTIONS

**HDMI 2 and 3:** Each code set controls a source device (VCR/PVR, DVD player or cable/satellite set-top box) connected to one of these inputs.

**AUX:** Controls a device connected to the Auxiliary Input. Any given button may have different functions, depending on which component is being controlled. Some buttons are labeled with these functions. For example, the Sleep Button is labeled for use as the Channel Up Button when controlling a television or cable box. See Table A10 in the appendix for listings of the different functions for each type of component.

**IR Transmitter Lens:** As buttons are pressed on the remote, infrared codes are emitted through this lens.

**Power On Button:** Press this button to turn on the AVR or another device. The Main Power Switch must first have been switched on.

**Mute Button:** Press to mute the AVR 160's speaker and headphone outputs. To end the muting, press this button, adjust the volume, or turn off the receiver.

**Program Indicator:** This LED lights up or flashes in one of three colors as the remote is programmed with codes.

**Power Off Button:** Press to turn off the AVR 160 or another device.

**AVR Selector:** Press to switch the remote to AVR device mode.

**Source Selectors:** Press one of these buttons to select a source device, e.g., DVD, CD, cable TV, satellite or HDTV tuner. This will also turn on the receiver and switch the remote's device mode to operate the source.

**AM/FM Button:** Press this button to select the tuner as the source, or to switch between the AM and FM bands.

**6-/8-Channel Input Selector:** Press this button to select the 6-/8-Channel Inputs as the audio source. If a signal is present at the component video inputs assigned to this source, it will be used. If not, the receiver will use the video input and remote control codes for the last-selected analog video source.

**Test Tone:** Press this button to activate the test tone for manual output-level calibration.

**TV/Video:** This button has no effect on the receiver, but is used to switch video inputs on some video source components.

**Sleep Button:** Press this button to activate the sleep timer, which turns off the receiver after a programmed period of time of up to 90 minutes.

**Channel Controls:** These buttons have no effect on the receiver, but are used to change channels on TVs and some video sources.

**Volume Control:** Press to raise or lower the volume, which will be shown in decibels (dB) in the Message Display.

**On-Screen Display (OSD):** Press this button to activate the on-screen menu system.

**Channel Level:** Press this button to adjust the output levels for any channel so that all speakers sound equally loud at the listening position.

**Speaker Setup:** Press this button to configure speaker sizes, that is, the low-frequency capability of each speaker.

**Navigation (▲▼◀▶) and OK Buttons:** These buttons are used to make selections within the on-screen menu system, or when accessing the functions of the four buttons surrounding this area of the remote – Channel Level, Speaker Setup, Digital Input or Delay.

**Digital Input Select:** Press this button to select the specific digital audio input (or analog audio input) to which the current source is connected.

**Delay:** Press this button to set delay times that compensate for placing the speakers at different distances from the listening position, or to resolve a "lip sync" issue that may be caused by digital video processing.

**NOTE:** The Channel Level, Speaker Setup, Digital Input Select and Delay functions may also be adjusted using the OSD on-screen menus. In addition, the EzSet/EQ system may be used to adjust the Channel Level, Speaker Setup and Delay settings automatically.

**Numeric Keys:** Use these buttons to enter radio station frequencies or to select station presets. Press the Direct Button before entering the station frequency.

**Tuning Mode:** This button toggles between manual (one frequency step at a time) and automatic (seeks frequencies with acceptable signal strength) tuning mode. It also toggles between stereo and mono modes when an FM station is tuned.

**Memory:** After you have tuned a particular radio station, press this button, then the Numeric Keys, to save that station as a radio preset.

**Tuning:** Press these buttons to tune a radio station. Depending on whether the tuning mode has been set to manual or automatic, each press will either change one frequency step at a time, or seek the next frequency with acceptable signal strength.

# REMOTE CONTROL FUNCTIONS

ENGLISH

**Direct:** Press this button before using the Numeric Keys to directly enter a radio station frequency.

**Clear:** Press this button to clear a radio station frequency you have started to enter.

**Preset Stations Selector:** Press these buttons to select a preset radio station.

**Tone Mode:** Press this button to access the tone controls (bass and treble). Use the Navigation Buttons to make your selections.

**RDS:** Activates RDS functions for FM Radio

**Macros:** These buttons may be programmed to execute long command sequences with a single button press. They are useful for programming the command to turn on or off all of your components, or for accessing specialized functions for a different component than you are currently operating.

**Night Mode:** Press this button to activate Night mode with specially encoded Dolby Digital discs or broadcasts. Night mode compresses the audio so that louder passages are reduced in volume to avoid disturbing others, while dialogue remains intelligible.

**Track Skip:** These buttons have no effect on the receiver, but are used with many source components to change tracks or chapters.

**Dim:** Press this button to partially or fully dim the front-panel display.

**Transport Controls:** These buttons have no effect on the receiver, but are used to control many source components. By default, when the remote is operating the receiver, these buttons will control a Harman Kardon Blu-ray Disc player or a DVD player.

**Instructions for users on removal and disposal of used batteries.**  
**Specification of included battery types.**



These symbols shown on the product, the packaging or in the manual or separate information sheet mean that the product itself, as well as the batteries included or built into the product, should never be thrown away with general household waste. Take them to suitable collection points, where proper treatment, recycling and recovery take place, in accordance with national or local legislation, or European Directives 2002/96/EC and 2006/66/EC.

Correct handling of the product and batteries to be disposed of helps to save resources and prevents possible negative effects on the environment or human health.

The batteries included with your equipment may be Alkaline, Carbon Zinc/ Manganese or Lithium (button cells) type. All types should be disposed of according to the above instructions.

To remove the batteries from your equipment or remote control, reverse the procedure described for inserting batteries in the Owners Manual.

For products with a built-in battery that lasts for the lifetime of the product, removal may not be possible for the user. In this case, recycling or recovery centers handle the dismantling of the product and the removal of the battery. If, for any reason, it becomes necessary to replace such a battery, this procedure must be performed by authorized service centers.

# TROUBLESHOOTING GUIDE

SYMPTOM	CAUSE	SOLUTION
Unit does not function when Main Power Switch is turned on	<ul style="list-style-type: none"> <li>No AC Power</li> </ul>	<ul style="list-style-type: none"> <li>Make certain AC power cord is plugged into a live outlet</li> <li>Check whether outlet is switch-controlled</li> </ul>
Display lights, but no sound or picture	<ul style="list-style-type: none"> <li>Intermittent input connections</li> <li>Mute is on</li> <li>Volume control is down</li> </ul>	<ul style="list-style-type: none"> <li>Secure all input and speaker connections</li> <li>Press Mute Button</li> <li>Turn up volume control</li> </ul>
No sound from any speaker; PROTECT message appears on front panel	<ul style="list-style-type: none"> <li>Amplifier is in protection mode due to possible short</li> <li>Amplifier is in protection mode due to internal problems</li> </ul>	<ul style="list-style-type: none"> <li>Check speaker wires for shorts at receiver and speaker ends</li> <li>Contact your local Harman Kardon service center</li> </ul>
No sound from surround or center speakers	<ul style="list-style-type: none"> <li>Incorrect surround mode</li> <li>Input is monaural</li> <li>Incorrect configuration</li> <li>Stereo or Mono program material</li> </ul>	<ul style="list-style-type: none"> <li>Select a mode other than Stereo</li> <li>There is no surround information from mono sources</li> <li>Check speaker configuration</li> <li>The surround decoder may not create center- or rear-channel information from nonencoded programs</li> </ul>
Unit does not respond to remote commands	<ul style="list-style-type: none"> <li>Weak batteries in remote</li> <li>Wrong device selected</li> <li>Remote sensor is obscured</li> </ul>	<ul style="list-style-type: none"> <li>Change remote batteries</li> <li>Press the AVR Settings Button</li> <li>Make certain front-panel sensor is in line of sight of remote or connect an optional remote sensor</li> </ul>
Intermittent buzzing in tuner	<ul style="list-style-type: none"> <li>Local interference</li> </ul>	<ul style="list-style-type: none"> <li>Move unit or antenna away from computers, fluorescent lights, motors or other electrical appliances</li> </ul>

Additional information on troubleshooting possible problems with your AVR 160, or installation-related issues, may be found in the list of "Frequently Asked Questions", which is located in the Product Support section at [www.harmankardon.com](http://www.harmankardon.com).

## PROCESSOR RESET

If the unit behaves erratically after a power surge, first turn off the Main Power Switch and unplug the AC power cord for at least 3 minutes. Plug the cord back in and turn the receiver on. If this doesn't help, reset the AVR.

**NOTE:** A system reset erases all user configurations, including video resolution, speaker and level settings, and tuner presets. After a reset, reenter all of these settings from your notes in the appendix worksheets.

To reset the AVR 160, place it in Standby mode (press the front-panel Standby/On Switch so that the Power Indicator turns amber). Then press the front-panel Surr. Mode Button until the RESET message appears.

If the receiver does not function correctly after a processor reset, contact an authorized Harman Kardon service center for assistance. Authorized service centers may be located by visiting the Web site at [www.harmankardon.com](http://www.harmankardon.com).

## MEMORY

If the AVR 160 is unplugged or experiences a power outage, it will retain user settings for up to two weeks.

# TECHNICAL SPECIFICATIONS

## Audio Section

Stereo Mode, Continuous Average Power (FTC)	
40 Watts per channel, 20Hz–20kHz, @ <0.07% THD, both channels driven into 8 ohms	
Seven-Channel Surround Modes	
Power per Individual Channel	
Front L & R channels:	
40 Watts per channel @ <0.07% THD, 20Hz–20kHz into 8 ohms	
Center channel:	
40 Watts @ <0.07% THD, 20Hz–20kHz into 8 ohms	
Surround (L & R Side, L & R Back) channels:	
40 Watts per channel @ <0.07% THD, 20Hz–20kHz into 8 ohms	
Input Sensitivity/Impedance	
Linear (High-Level)	200mV/47k ohms
Signal-to-Noise Ratio (IHF-A)	
100dB	
Surround System Adjacent Channel Separation	
Pro logic® II	40dB
Dolby® Digital (AC-3)	55dB
DTS®	55dB
Frequency Response	
@ 1W (+0dB, –3dB)	10Hz –130kHz
High Instantaneous Current Capability (HCC)	
±25 Amps	
Transient Intermodulation Distortion (TIM)	
Unmeasurable	
Slew Rate	
40V/μsec	

## FM Tuner Section

Frequency Range	87.5–108.0MHz
Usable Sensitivity	IHF 1.3μV/13.2dB
Signal-to-Noise Ratio	Mono/Stereo 70/68dB
Distortion	Mono/Stereo 0.2/0.3%
Stereo Separation	40dB @ 1kHz
Selectivity	±400kHz, 70dB
Image Rejection	80dB
IF Rejection	90dB

## AM Tuner Section

Frequency Range	520-1710 kHz
Signal-to-Noise Ratio	45dB
Usable Sensitivity	Loop 500μV
Distortion	1kHz, 50% Mod 0.8%
Selectivity	±10kHz, 30dB

## Video Section

Television Format	PAL/NTSC	
Input Level/Impedance	1Vp-p/75 ohms	
Output Level/Impedance	1Vp-p/75 ohms	
Video Frequency Response (Composite)	10Hz–8MHz (–3dB)	
Video Frequency Response (Component Video)	10Hz–100MHz (–3dB)	
HDMI™	Version 1.3a with 10-bit Deep Color	

## General

Power Requirement	230-240V, 50/60Hz	
Power Consumption	540W maximum (7 channels driven)	
Stand-by consumption	<1W	
Dimensions	(Product)	(Shipping)
	Width	440mm 555mm
	Height	165mm 266mm
Depth	382mm 465mm	
	Weight	(Product)
	9.1kg	10.9kg

Depth measurement includes knobs, buttons and terminal connections.

Height measurement includes feet and chassis.

Features, specifications and appearance are subject to change without notice.

Harman Kardon and Logic 7 are trademarks of Harman International Industries, Incorporated, registered in the United States and/or other countries. EzSet/EQ, Designed to Entertain and The Bridge II logo are trademarks of Harman International Industries, Incorporated. Blu-ray Disc is a trademark of the Blu-ray Disc Association.

CEA is a registered trademark of the Consumer Electronics Association.

Manufactured under license from Dolby Laboratories. Dolby, Pro Logic, and the double-D symbol are registered trademarks of Dolby Laboratories. MLP Lossless is a trademark of Dolby Laboratories.

Manufactured under license under U.S. Patent #'s 5,451,942; 5,956,674; 5,974,380; 5,978,762; 6,226,616; 6,487,535; 7,212,872; 7,333,929; 7,392,195; 7,272,567 and other U.S. and worldwide patents issued and pending. DTS is a registered trademark and the DTS logos, Symbol, DTS-HD and DTS-HD Master Audio are trademarks of DTS, Inc. © 1996-2008 DTS, Inc. All Rights Reserved.

Faroudja DCi Cinema is a trademark of Genesis Microchip Inc.

HD-DVD is a trademark of the DVD Format/Logo Licensing Corporation (DVD FLLC).

HDMI, the HDMI logo and High-Definition Multimedia Interface are trademarks or registered trademarks of HDMI Licensing LLC.

iPod is a trademark of Apple Inc., registered in the U.S. and other countries.

SACD is a trademark of Sony Corporation.

TiVo is a registered trademark of TiVo Inc.

Please register your AVR 160 at [www.harmankardon.com](http://www.harmankardon.com).

**NOTE:** You'll need the product's serial number. At the same time, you can choose to be notified about new products and/or special promotions.

### 1. Instruction manual ass'y - Accessories

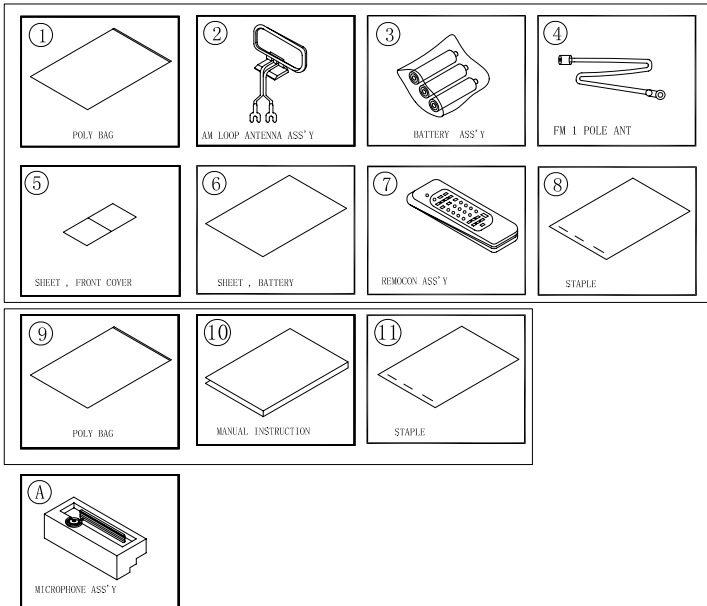

ACCESSORY-1			
NO	DESCRIPTION	PARTS NO.	Q. ty
1	POLY BAG	CPB1061W	1
2	ANT, AM LOOP	CSA1A032Z	1
3	BATTERY, AAA	CABR003PB	3
4	FM 1 POL ANT	CSA1A018Z	1
5	SHEET, FRONT COVER	CQE1A220Z	1
6	SHEET, BATTERY	CQE1A411Z	1
7	REMOCON ASS'Y	CARTAVR160E-0K	1
8	STAPLE	CP1.0905	3

ACCESSORY-2			
NO	DESCRIPTION	PARTS NO.	Q. ty
9	POLY BAG	CPB1061W	1
10	MANUAL, INSTRUCTION	CQX1A1432Z	1
11	STAPLE	CP1.0905	3
A	MICROPHONE ASS'T	CJXAVR340MCR0	1

### 2. Package Drawing

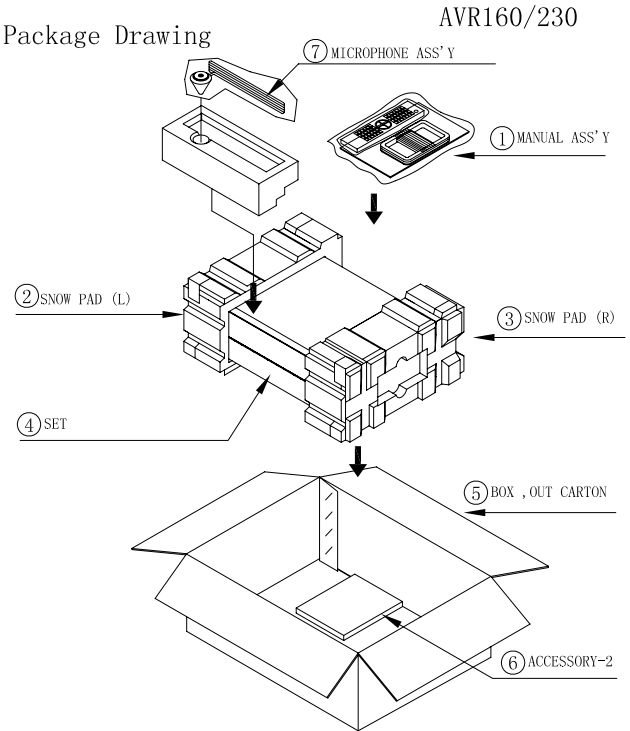

NO	DESCRIPTION	PARTS NO.	Q. ty
1	ACCESSORY-1	CQXAVR160/240	1
2	SNOW, PAD (L)	CPS5A564Z	1
3	SNOW, PAD (R)	CPS5A565Z	1
4	SET	AVR160/240SET	1
5	BOX, OUT CARTON	CPG1A891W	1
6	ACCESSORY-2	CQXAVR160/240	1
7	MICROPHONE ASS'Y	CJXAVR340MCR0	1

# DISASSEMBLY

# AVR160/230

1. Removing the Top Cabinet  
Remove the Screws ①-⑬

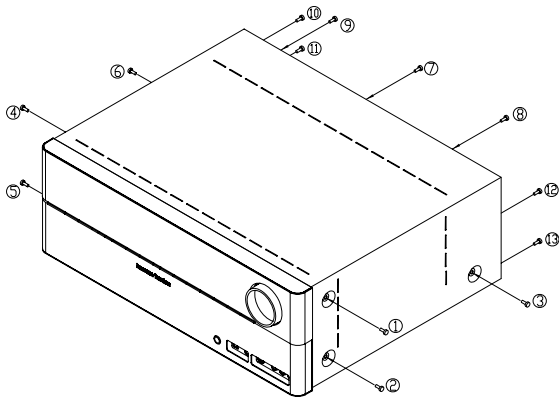

2. Removing the Front Panel  
Remove the Screws ①-⑧

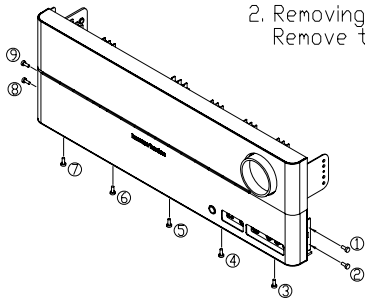

3. Removing the Rear Panel  
Remove the Screws ①-⑨

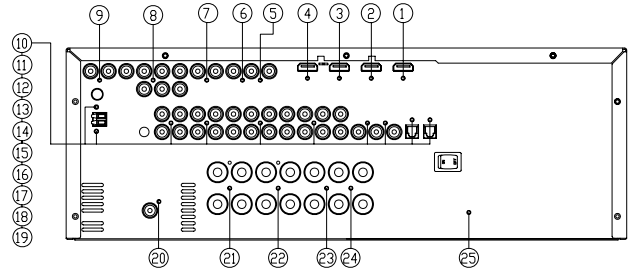

4. Removing the Main PCB  
Remove the Screws ①-⑦

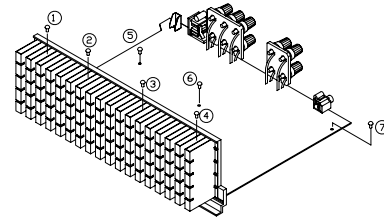



# AVR160/230 EXPLODE VIEW

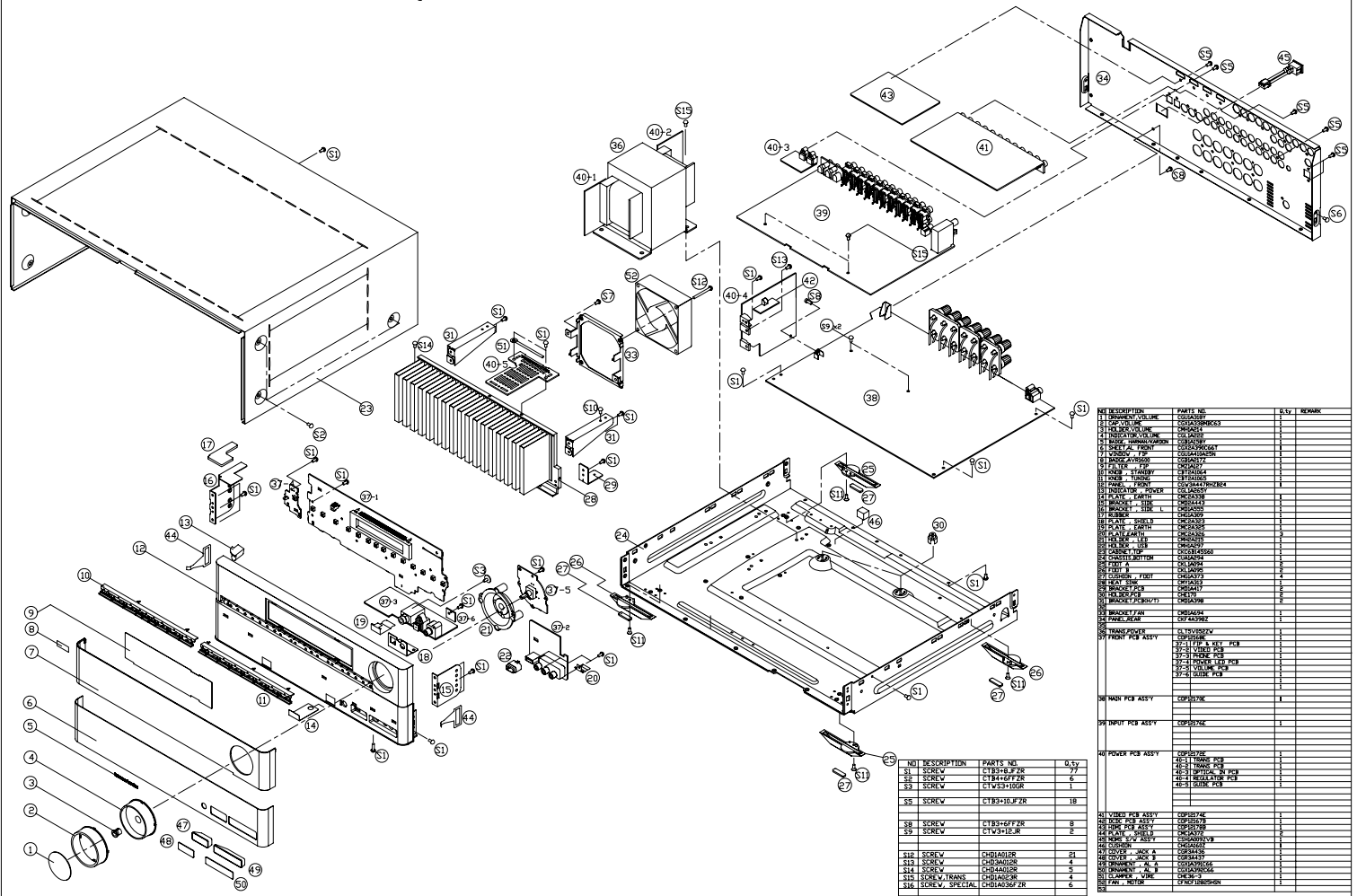

NO	DESCRIPTION	PARTS NO	Q.ty
S1	SCREW	01B3+8.FZR	77
S2	SCREW	01B4+6.FZR	4
S3	SCREW	01W3+10R	4
S4	SCREW	01B3+10.FZR	18
S5	SCREW	01B3+6.FZR	8
S6	SCREW	01W3+10.R	2
S10	SCREW	01D14010R	21
S11	SCREW	01D14010R	4
S14	SCREW	01D14010R	4
S15	SCREW, TRANS	01D14010R	4
S16	SCREW, SPECIAL	01D14036F.ZR	6

NO	DESCRIPTION	PARTS NO	Q.ty	REMARK
11	TOP COVER	01D14010R	1	
12	TOP COVER	01D14010R	1	
13	TOP COVER	01D14010R	1	
14	TOP COVER	01D14010R	1	
15	TOP COVER	01D14010R	1	
16	TOP COVER	01D14010R	1	
17	TOP COVER	01D14010R	1	
18	TOP COVER	01D14010R	1	
19	TOP COVER	01D14010R	1	
20	TOP COVER	01D14010R	1	
21	TOP COVER	01D14010R	1	
22	TOP COVER	01D14010R	1	
23	TOP COVER	01D14010R	1	
24	TOP COVER	01D14010R	1	
25	TOP COVER	01D14010R	1	
26	TOP COVER	01D14010R	1	
27	TOP COVER	01D14010R	1	
28	TOP COVER	01D14010R	1	
29	TOP COVER	01D14010R	1	
30	TOP COVER	01D14010R	1	
31	TOP COVER	01D14010R	1	
32	TOP COVER	01D14010R	1	
33	TOP COVER	01D14010R	1	
34	TOP COVER	01D14010R	1	
35	TOP COVER	01D14010R	1	
36	TOP COVER	01D14010R	1	
37	TOP COVER	01D14010R	1	
38	TOP COVER	01D14010R	1	
39	TOP COVER	01D14010R	1	
40	TOP COVER	01D14010R	1	
41	TOP COVER	01D14010R	1	
42	TOP COVER	01D14010R	1	
43	TOP COVER	01D14010R	1	
44	TOP COVER	01D14010R	1	
45	TOP COVER	01D14010R	1	
46	TOP COVER	01D14010R	1	
47	TOP COVER	01D14010R	1	
48	TOP COVER	01D14010R	1	
49	TOP COVER	01D14010R	1	
50	TOP COVER	01D14010R	1	
51	TOP COVER	01D14010R	1	
52	TOP COVER	01D14010R	1	
53	TOP COVER	01D14010R	1	
54	TOP COVER	01D14010R	1	
55	TOP COVER	01D14010R	1	
56	TOP COVER	01D14010R	1	
57	TOP COVER	01D14010R	1	

<b>AVR160/230 Electrical &amp; Mechanical Parts List</b>					
Level	Ref. #	Part Number	Description	Drawing No (Value)	Qty
0,2		CGB1A217Z	BADGE , AVR160		1
0,2		CGL1A222	INDICATOR , VOLUME	AVR130/230/330	1
0,2		CGR3A436	COVER , JACK A		1
0,2		CGR3A437	COVER , JACK B		1
0,2		CGU1A318Y	ORNAMENT , VOLUME AVR255		1
0,2		CGU1A410A25N	WINDOW , FIP		1
0,2		CGX1A338MBC63	CAP , VOLUME		1
0,2		CGX1A391C66	ORNAMENT , AL A AVR350		1
0,2		CGX1A392C66	ORNAMENT , AL B AVR350		1
0,2		CGX2A390C66T	SHEET , AL FRONT		1
0,2		CKC6B145S60	CABINET , TOP AVR350		1
0,2		CMH1A214	HOLDER , VOLUME	AVR130/230/330	1
0,2		CMZ2A090	SHEET , VOLUME		1
0,2		CQB1A549Y	LABEL , ATTENTION DVD48		1
0,2		CQB1A622	LABEL , SERIAL NO		1
0,2		CTB3+8JFZR	SCREW		17
0,2		CTB4+6FFZR	SCREW		6
1		CHE154	CLAMPER , ARM		0,12
1		CJXAVR340MICRO	MICRO PHONE ASS'Y		1
1		CPG1A891W	BOX , OUT CARTON		1
1		CPS5A564Z	PAD , SNOW L AVR155		1
1		CPS5A565Z	PAD , SNOW R AVR155		1
1		CQB1A907Z	LABEL , BAR CODE AVR154		1
1		CQB1A928Z	LABEL , MADE IN PRC		2
1		CQS1A001	RIBON , BAR CODE	SONY(TR-4070)	0,12
1		CQXAVR160/240	INSTRUCTION MANUAL ASS'Y		1
0,2		CARTAVR160E-HK	REMOCON ASS'Y (66KEY)	AVR160	1
0,2		CQB1A971	LABEL , BAR CODE(MANUAL)		1
0,2		CQE1A220Z	SHEET , FRONT COVER	AVR130/230BK	1
0,2		CQE1A411Z	SHEET , BATTERY HARMAN		1
0,2		CQX1A1432Z	MANUAL , INSTRUCTION		1
0,2		CSA1A018Z	FM 1 POLE ANT		1
0,2		CSA1A032Z	ANT , AM LOOP		1
<b>FRONT PANEL ASSY</b>					
Level	Ref. #	Part Number	Description	Drawing No (Value)	Qty
0,2		CGWAVR160/240	FRONT PANEL ASS'Y		1
..3		CBT2A1064	KNOB , STANDBY		1
..3		CBT2A1065	KNOB , BACK		1
..3		CGB1A158Y	BADGE , FRONT HARMAN/KARDON		1
..3		CGL1A265Y	INDICATOR , POWER AVR155		1
..3		CGW3A447RHZB24	PANEL , FRONT		1
..3		CHG1A309	RUBBER		1
..3		CHR301	CLAMPER		6
..3		CMC1A372	PLATE , SHIELD		2
..3		CMC2A323	PLATE , SHIELD		1
..3		CMC2A326	PLATE , EARTH AVR350		3
..3		CMC2A338	PLATE , EARTH AVR350		2
..3		CMD1A555	BRACKET , SIDE (L)		1
..3		CMD2A443	BRACKET , SIDE		1
..3		CMH1A297	HOLDER , USB		1
..3		CMH2A215	HOLDER , LED AVR350		1
..3		CMZ1A127	FILTER , FIP AVR255		1
..3		CPE1A009	SHEET , BLIND		1
..3		CTB3+8JFZR	SCREW		28
..3		CTWS3+10GR	SCREW		1
..3	CB72	CWC4C4A31B250B08	CARD , CABLE (31p,1.25mm,250mm,08mm)		1
<b>BOTTOM CHASSIS ASS'Y</b>					
Level	Ref. #	Part Number	Description	Drawing No (Value)	Qty
0,2		CUAAVR160/240	BOTTOM CHASSIS ASS'Y		1
..3		CHD1A012ZR	SCREW , SPECIAL		2
..3		CHD1A023R	SCREW , SPECIAL		4
..3		CHD4A012R	SCREW , SPECIAL		5
..3		CHE170	HOLDER , PCB		2
..3		CHE36-3	CLAMPER , WIRE		1
..3		CHG1A113	RUBBER		3
..3		CHG1A160Z	CUSHION , RUBBER		1
..3		CHG1A373	CUSHION , FOOT AVR350		4
..3		CHS1A032	TAPE , HEMELON		4
..3		CJA2B043ZA	CORD , POWER(EUR)	QDR-7100CC	1
..3		CKF4A398Z	PANEL , REAR		1
..3		CKL1A094	FOOT , A AVR350		2
..3		CKL1A095	FOOT , B AVR350		2
..3		CTB3+10JFZR	SCREW		18
..3		CTB3+6FFZR	SCREW		8

BOTTOM CHASSIS ASS'Y					
Level	Ref. #	Part Number	Description	Drawing No (Value)	Qty
..3		CTB3+8JFZR	SCREW		12
..3		CTS3+8JFZR	SCREW		4
..3		CTW3+12JR	SCREW		2
..3		CUA1A294	CHASSIS , BOTTOM		1
..3		KHR1A028	BUSHING , AC CORD		1
..3	BN90	CSH1A009ZVB	SWITCH , MOMS WIRE ASS'Y (2P, 80MM, RED)		1
...4		CSH1A009ZV	SWITCH , MOMS		1
..4		CWB4F202080UK	WIRE ASS'Y (3.96MM, 80MM, 2P, RED)		1
..3	CB12	CWC4C4A27B100B10	CARD , CABLE (27p,1.25mm Pitch,100mm Length,Protec		1
..3	CB14	CWC4C4A15B080B10	CABLE , CARD (15P,1.25MM,80MM,B,10MM)		1
..3	CB15	CWC4F2A17A100B10	CARD , CABLE (17P,1.0mm Pitch,100mm Length,Protect		1
..3	F901	KBA2C4000TLEY	FUSE(218 Series, 250V, 4A)	4A/250V(EUR)	1
..3	T901	CLT5V052ZW	TRANS , POWER (AC240V/50Hz)		1
FRONT PCB ASSY					
Level	Ref. #	Part Number	Description	Drawing No (Value)	Qty
..3		COP12168E	AVR160 FRONT PCB ASS'Y		1
...5	C121	CCBS1H151KBT	CAP , CERAMIC(150PF/50V)	CH UP025 B151K-A-B Z	1
...5	C122	CCEA1AH331T	CAP , ELECT	330UF 10V	1
...5	C151	CCBS1H473ZFT	CAP , CERAMIC(47000PF/50V)	CH UP025 F473Z-A-B J	1
...5	C152	CCEA1CKS100T	CAP , ELECT	10UF 16V	1
...5	C161	CCBS1H104ZFT	CAP , CERAMIC	0.1UF 50V Z	1
...5	C213	CCBS1H223ZFT	CAP , CERAMIC(22000PF/50V)	CH UP025 F223Z-A-B J	1
...5	C214	CCBS1H223ZFT	CAP , CERAMIC(22000PF/50V)	CH UP025 F223Z-A-B J	1
...5	C252	CCEA1HKS2R2T	CAP , ELECT	2.2UF 50V SMALL SIZE	1
...5	C311	CCBS1H102KBT	CAP , CERAMIC(1000PF/50V)	CH UP025 B102K-A-B Z	1
...5	C322	CCBS1H102KBT	CAP , CERAMIC(1000PF/50V)	CH UP025 B102K-A-B Z	1
...5	C412	CCBS1H103ZFT	CAP , CERAMIC	0.01UF 50V Z	1
...5	C413	CCEA1JH470TS	CAP , ELECT	63V/47UF/105°C	1
...5	C414	CCEA1JH470TS	CAP , ELECT	63V/47UF/105°C	1
...5	C415	CCBS1H103ZFT	CAP , CERAMIC	0.01UF 50V Z	1
...5	C422	CCEA1HH4R7T	CAP , ELECT	4.7UF 50V	1
...5	C431	CCBS1H104ZFT	CAP , CERAMIC	0.1UF 50V Z	1
...5	C441	CCBS1H223ZFT	CAP , CERAMIC(22000PF/50V)	CH UP025 F223Z-A-B J	1
...5	C442	CCBS1H223ZFT	CAP , CERAMIC(22000PF/50V)	CH UP025 F223Z-A-B J	1
...5	C503	CCBS1H104ZFT	CAP , CERAMIC	0.1UF 50V Z	1
...5	C504	CCBS1H103ZFT	CAP , CERAMIC	0.01UF 50V Z	1
...5	C511	CCBS1H560JT	CAP , CERAMIC(56PF/50V)	CH UP025SL560J-A-B Z	1
...5	C512	CCBS1H560JT	CAP , CERAMIC(56PF/50V)	CH UP025SL560J-A-B Z	1
...5	C521	CCEA1AH101T	CAP , ELECT	100UF 10V	1
...5	C522	CCBS1H103ZFT	CAP , CERAMIC	0.01UF 50V Z	1
...5	C531	CCBS1H104ZFT	CAP , CERAMIC	0.1UF 50V Z	1
...5	C533	CCBS1H104ZFT	CAP , CERAMIC	0.1UF 50V Z	1
...5	C541	CCBS1H101KBT	CAP , CERAMIC(100PF/50V)	CH UP025 B101K-A-B Z	1
...5	C542	CCEA1HH100T	CAP , ELECT	10UF 50V	1
...5	C553	CCBS1H471KBT	CAP , CERAMIC(470PF/50V)	CH UP025 B471K-A-B Z	1
...5	C554	CCBS1H471KBT	CAP , CERAMIC(470PF/50V)	CH UP025 B471K-A-B Z	1
...5	C601	CCBS1H181KBT	CAP , CERAMIC(180PF/50V)	CH UP025 B181K-A-B Z	1
...5	C602	CCBS1H104ZFT	CAP , CERAMIC	0.1UF 50V Z	1
...5	C603	CCBS1H100JCT	CAP , CERAMIC(10PF/50V)	CH UP025CH100J-A-B Z	1
...5	C611	CCEA1AH471T	CAP , ELECT	470UF 10V	1
...5	C612	CCBS1H104ZFT	CAP , CERAMIC	0.1UF 50V Z	1
...5	C631	CCBS1H104ZFT	CAP , CERAMIC	0.1UF 50V Z	1
...5	C633	CCBS1H104ZFT	CAP , CERAMIC	0.1UF 50V Z	1
...5	C651	CCBS1H104ZFT	CAP , CERAMIC	0.1UF 50V Z	1
...5	C652	CCBS1H681KBT	CAP , CERAMIC(680PF/50V)	CH UP025 B681K-A-B Z	1
...5	C653	CCBS1H681KBT	CAP , CERAMIC(680PF/50V)	CH UP025 B681K-A-B Z	1
...5	C714	CCBS1H223ZFT	CAP , CERAMIC(22000PF/50V)	CH UP025 F223Z-A-B J	1
...5	C715	CCEA1CKS100T	CAP , ELECT	10UF 16V	1
...5	C721	CCEA1HKS2R2T	CAP , ELECT	2.2UF 50V SMALL SIZE	1
...5	C731	CCEA1AH471T	CAP , ELECT	470UF 10V	1
...5	C732	CCBS1H104ZFT	CAP , CERAMIC	0.1UF 50V Z	1
...5	C751	CCBS1C222MXT	CAP , CERAMIC(2200PF/16V)	CH EP025 B222M-A-B J	1
...5	C752	CCBS1H102KBT	CAP , CERAMIC(1000PF/50V)	CH UP025 B102K-A-B Z	1
...5	C753	CCBS1H102KBT	CAP , CERAMIC(1000PF/50V)	CH UP025 B102K-A-B Z	1
...5	C754	CCBS1H104ZFT	CAP , CERAMIC	0.1UF 50V Z	1
...5	C801	CCEA1EH470T	CAP , ELECT	47UF 25V	1
...5	C802	CCEA1EH470T	CAP , ELECT	47UF 25V	1
...5	C811	CCEA1HH100T	CAP , ELECT	10UF 50V	1
...5	C813	CCBS1H470JT	CAP , CERAMIC(47PF/50V)	CH UP025SL470J-A-B Z	1
...5	C821	CCBS1H471KBT	CAP , CERAMIC(470PF/50V)	CH UP025 B471K-A-B Z	1
...5	C822	CCBS1H151KBT	CAP , CERAMIC(150PF/50V)	CH UP025 B151K-A-B Z	1
...5	C823	CCEA1HH100T	CAP , ELECT	10UF 50V	1
...5	C830	CCBS1H473ZFT	CAP , CERAMIC(47000PF/50V)	CH UP025 F473Z-A-B J	1
...5	C901	CCEA1HH100T	CAP , ELECT	10UF 50V	1
...5	C902	CCEA1HH100T	CAP , ELECT	10UF 50V	1
...5	C911	CCEA1EH470T	CAP , ELECT	47UF 25V	1
...5	C912	CCEA1EH470T	CAP , ELECT	47UF 25V	1

FRONT PCB ASSY					
Level	Ref. #	Part Number	Description	Drawing No (Value)	Qty
....5	C923	CCBS1H681KBT	CAP , CERAMIC(680PF/50V)	CH UP025 B681K-A-B Z	1
....5	C924	CCBS1H681KBT	CAP , CERAMIC(680PF/50V)	CH UP025 B681K-A-B Z	1
....5	C931	CCEA1CH331T	CAP , ELECT	330UF 16V	1
....5	C932	CCEA1CH331T	CAP , ELECT	330UF 16V	1
....5	D161	HVD1N5819T	DIODE , SCHOTTKY	1N5819	1
....5	D401	CVD1N4003ST	DIODE , RECT	1N4003	1
....5	D412	HVDMTZJ6.8BT	DIODE , ZENER	MTZJ6.8B 1/2W	1
....5	D413	HVDMTZJ27BT	DIODE , ZENER	MTZJ27B 1/2W	1
....5	D421	HVDMTZJ6.8BT	DIODE , ZENER	MTZJ6.8B 1/2W	1
....5	D422	HVDMTZJ6.8BT	DIODE , ZENER	MTZJ6.8B 1/2W	1
....5	D455	CVD1SS133MT	DIODE	1SS133	1
....5	D531	CVD1SS133MT	DIODE	1SS133	1
....5	D534	CVD1SS133MT	DIODE	1SS133	1
....5	D631	CVD1SS133MT	DIODE	1SS133	1
....5	D632	CVD1SS133MT	DIODE	1SS133	1
....5	D633	CVD1SS133MT	DIODE	1SS133	1
....5	D634	CVD1SS133MT	DIODE	1SS133	1
....5	L151	HLQ02C100KT	COIL , AXAIL (10UH)		1
....5	Q104	CVTKTC1027YT	T.R		1
....5	Q111	HVTKRA107MT	T.R	KRA107M	1
....5	Q112	HVTKRC107MT	T.R	KRC107M	1
....5	Q113	HVTKRC107MT	T.R	KRC107M	1
....5	Q251	HVTKTA1271YT	T.R	KTA1271Y	1
....5	Q252	HVTKRC107MT	T.R	KRC107M	1
....5	Q721	HVTKRC107MT	T.R	KRC107M	1
....5	Q941	HVTKTC2874BT	T.R , MUTE	KTC2874B	1
....5	Q942	HVTKTC2874BT	T.R , MUTE	KTC2874B	1
....5	Q943	HVTKTC2874BT	T.R , MUTE	KTC2874B	1
....5	Q944	HVTKTC2874BT	T.R , MUTE	KTC2874B	1
....5	Q951	HVTKRC107MT	T.R	KRC107M	1
....5	Q952	HVTKRA107MT	T.R	KRA107M	1
....5	Q954	HVTKRC107MT	T.R	KRC107M	1
....5	R101	CRD20TF2200T	RES , CARBON(220 OHM, 1%)		1
....5	R102	CRD20TF6800T	RES , CARBON(680 OHM, 1%)		1
....5	R113	CRD20TJ102T	RES , CARBON	1K OHM 1/5W J	1
....5	R121	CRD20TJ473T	RES , CARBON	47K OHM 1/5W J	1
....5	R122	CRD20TJ100T	RES , CARBON	10 OHM 1/5W J	1
....5	R201	CRD20TJ101T	RES , CARBON(1/5W,100,5%)	100 OHM 1/5W J	1
....5	R202	CRD20TJ101T	RES , CARBON(1/5W,100,5%)	100 OHM 1/5W J	1
....5	R203	CRD20TJ101T	RES , CARBON(1/5W,100,5%)	100 OHM 1/5W J	1
....5	R211	CRD20TJ101T	RES , CARBON(1/5W,100,5%)	100 OHM 1/5W J	1
....5	R213	CRD20TJ272T	RES , CARBON	2.7K OHM 1/5W J	1
....5	R214	CRD20TJ272T	RES , CARBON	2.7K OHM 1/5W J	1
....5	R251	CRD20TJ222T	RES , CARBON	2.2K OHM 1/5W J	1
....5	R252	CRD25TJ393T	RES , CARBON (39K OHM)		1
....5	R312	CRD20TF1001T	RES , CARBON	1K /1/5W /F	1
....5	R313	CRD20TF1501T	RES , CARBON	1.5K /1/5W /F	1
....5	R314	CRD20TF1801T	RES , CARBON	1.8K /1/5W /F	1
....5	R315	CRD20TF2701T	RES , CARBON	2.7K /1/5W/F	1
....5	R316	CRD20TF3301T	RES , CARBON	3.3K /1/5W/F	1
....5	R322	CRD20TF1001T	RES , CARBON	1K /1/5W /F	1
....5	R323	CRD20TF1501T	RES , CARBON	1.5K /1/5W /F	1
....5	R324	CRD20TF1801T	RES , CARBON	1.8K /1/5W /F	1
....5	R325	CRD20TF2701T	RES , CARBON	2.7K /1/5W/F	1
....5	R326	CRD20TF3301T	RES , CARBON	3.3K /1/5W/F	1
....5	R327	CRD20TF5601T	RES , CARBON(5.6K/F)		1
....5	R328	CRD20TF5601T	RES , CARBON(5.6K/F)		1
....5	R401	CRD25FJ3R3T	RES , CARBON	3.3 OHM 1/4W J	1
....5	R402	CRD25TJ5R6T	RES , CARBON (5.6 OHM)		1
....5	R403	CRD20TJ100T	RES , CARBON	10 OHM 1/5W J	1
....5	R404	CRD25TJ5R6T	RES , CARBON (5.6 OHM)		1
....5	R411	CRD20TJ104T	RES , CARBON	100K OHM 1/5W J	1
....5	R412	CRD20TJ122T	RES , CARBON	1.2K OHM 1/5W J	1
....5	R413	CRD20TJ104T	RES , CARBON	100K OHM 1/5W J	1
....5	R415	CRD20TJ473T	RES , CARBON	47K OHM 1/5W J	1
....5	R431	CRD20TJ100T	RES , CARBON	10 OHM 1/5W J	1
....5	R432	CRD20TJ100T	RES , CARBON	10 OHM 1/5W J	1
....5	R511	CRD20TJ100T	RES , CARBON	10 OHM 1/5W J	1
....5	R512	CRD20TJ100T	RES , CARBON	10 OHM 1/5W J	1
....5	R513	CRD20TJ153T	RES , CARBON	15K OHM 1/5W J	1
....5	R514	CRD20TJ153T	RES , CARBON	15K OHM 1/5W J	1
....5	R541	CRD20TJ750T	RES , CARBON	75 OHM 1/5W J	1
....5	R551	CRD20TJ221T	RES , CARBON	220 OHM 1/5W J	1
....5	R552	CRD20TJ221T	RES , CARBON	220 OHM 1/5W J	1
....5	R553	CRD20TJ104T	RES , CARBON	100K OHM 1/5W J	1
....5	R554	CRD20TJ104T	RES , CARBON	100K OHM 1/5W J	1
....5	R601	CRD20TJ750T	RES , CARBON	75 OHM 1/5W J	1
....5	R603	CRD20TJ104T	RES , CARBON	100K OHM 1/5W J	1
....5	R604	CRD20TJ472T	RES , CARBON	4.7K OHM 1/5W J	1

FRONT PCB ASSY					
Level	Ref. #	Part Number	Description	Drawing No (Value)	Qty
...5	R612	CRD20TJ103T	RES , CARBON	10K OHM 1/5W J	1
...5	R701	CRD20TJ102T	RES , CARBON	1K OHM 1/5W J	1
...5	R702	CRD20TJ102T	RES , CARBON	1K OHM 1/5W J	1
...5	R703	CRD20TJ102T	RES , CARBON	1K OHM 1/5W J	1
...5	R711	CRD20TJ470T	RES , CARBON	47 OHM 1/5W J	1
...5	R712	CRD20TJ470T	RES , CARBON	47 OHM 1/5W J	1
...5	R713	CRD20TJ470T	RES , CARBON	47 OHM 1/5W J	1
...5	R721	CRD20TJ103T	RES , CARBON	10K OHM 1/5W J	1
...5	R722	CRD20TJ101T	RES , CARBON(1/5W,100,5%)	100 OHM 1/5W J	1
...5	R731	CRD20TJ100T	RES , CARBON	10 OHM 1/5W J	1
...5	R735	CRD20TJ152T	RES , CARBON	1.5K OHM 1/5W J	1
...5	R741	CRD20TJ123T	RES , CARBON	12K OHM 1/5W J	1
...5	R742	CRD20TJ102T	RES , CARBON	1K OHM 1/5W J	1
...5	R801	CRD20TJ101T	RES , CARBON(1/5W,100,5%)	100 OHM 1/5W J	1
...5	R802	CRD20TJ101T	RES , CARBON(1/5W,100,5%)	100 OHM 1/5W J	1
...5	R811	CRD20TJ104T	RES , CARBON	100K OHM 1/5W J	1
...5	R812	CRD20TJ102T	RES , CARBON	1K OHM 1/5W J	1
...5	R813	CRD20TJ103T	RES , CARBON	10K OHM 1/5W J	1
...5	R821	CRD20TJ102T	RES , CARBON	1K OHM 1/5W J	1
...5	R822	CRD20TJ103T	RES , CARBON	10K OHM 1/5W J	1
...5	R823	CRD20TJ104T	RES , CARBON	100K OHM 1/5W J	1
...5	R834	CRD20TJ222T	RES , CARBON	2.2K OHM 1/5W J	1
...5	R835	CRD20TJ103T	RES , CARBON	10K OHM 1/5W J	1
...5	R836	CRD20TJ152T	RES , CARBON	1.5K OHM 1/5W J	1
...5	R901	CRD25TJ101T	RES , CARBON (100 OHM)		1
...5	R902	CRD20TJ101T	RES , CARBON(1/5W,100,5%)	100 OHM 1/5W J	1
...5	R911	CRD20TJ101T	RES , CARBON(1/5W,100,5%)	100 OHM 1/5W J	1
...5	R912	CRD20TJ101T	RES , CARBON(1/5W,100,5%)	100 OHM 1/5W J	1
...5	R921	CRD20TJ102T	RES , CARBON	1K OHM 1/5W J	1
...5	R922	CRD20TJ102T	RES , CARBON	1K OHM 1/5W J	1
...5	R923	CRD20TJ152T	RES , CARBON	1.5K OHM 1/5W J	1
...5	R924	CRD20TJ152T	RES , CARBON	1.5K OHM 1/5W J	1
...5	R925	CRD20TJ104T	RES , CARBON	100K OHM 1/5W J	1
...5	R926	CRD20TJ104T	RES , CARBON	100K OHM 1/5W J	1
...5	R931	CRD20TJ104T	RES , CARBON	100K OHM 1/5W J	1
...5	R932	CRD20TJ104T	RES , CARBON	100K OHM 1/5W J	1
...5	R933	CRD20TJ221T	RES , CARBON	220 OHM 1/5W J	1
...5	R934	CRD20TJ221T	RES , CARBON	220 OHM 1/5W J	1
...5	R935	CRD20TJ221T	RES , CARBON	220 OHM 1/5W J	1
...5	R936	CRD20TJ221T	RES , CARBON	220 OHM 1/5W J	1
...5	R941	CRD25TJ432T	RES , CARBON(1/4W, 4.3K)		1
...5	R942	CRD20TJ472T	RES , CARBON	4.7K OHM 1/5W J	1
...5	R943	CRD20TJ472T	RES , CARBON	4.7K OHM 1/5W J	1
...5	R944	CRD20TJ472T	RES , CARBON	4.7K OHM 1/5W J	1
...5	R951	CRD20TJ102T	RES , CARBON	1K OHM 1/5W J	1
...5	R953	CRD20TJ362T	RES , CARBON	3.6K OHM 1/5W J	1
...5	R954	CRD20TJ103T	RES , CARBON	10K OHM 1/5W J	1
...5	S311	CST1A024ZT	SW , TACT		1
...5	S312	CST1A024ZT	SW , TACT		1
...5	S313	CST1A024ZT	SW , TACT		1
...5	S314	CST1A024ZT	SW , TACT		1
...5	S315	CST1A024ZT	SW , TACT		1
...5	S316	CST1A024ZT	SW , TACT		1
...5	S317	CST1A024ZT	SW , TACT		1
...5	S318	CST1A024ZT	SW , TACT		1
...5	S319	CST1A024ZT	SW , TACT		1
...5	S320	CST1A024ZT	SW , TACT		1
...5	S321	CST1A024ZT	SW , TACT		1
...5	S322	CST1A024ZT	SW , TACT		1
...5	S323	CST1A024ZT	SW , TACT		1
...5	S330	CST1A024ZT	SW , TACT		1
...4	BK71	CMD1A572	BRACKET , FIP		1
...4	BK72	CMD1A572	BRACKET , FIP		1
...4	BN51	CWB1C907250BM001	SHIELD WIRE ASS'Y (2.5mm, 250mm, 7pin)		1
...4	BN52	CWB1C903400BM001	SHIELD WIRE ASS'Y (2.5mm, 400mm, 3pin)		1
...4	BN61	CJP12GB143ZB	PIN HEADER , DIP SOCKET(12PIN, 2.54mm, ANGLE)		1
...4	BN73	CJP06GB143ZB	FEMALE HEADER(6P, 2.54mm)		1
...4	BN74	CWB1C905120BM	WIRE ASS'Y		1
...4	CN61	CJP12GA239ZB	PIN HEADER(12P, 2.54mm), STRAIGHT TYPE		1
...4	CN71	CJP05GB03ZY	WAFER , ANGLE (2.5mm)		1
...4	CN72	CJP31GA41ZM	WAFER (1.25MM, CARD CABLE, STRAIGHT 3	MOLEX 52045-**45	1
...4	CN73	CJP06GB142ZB	PIN HEADER(6P, 2.54mm)		1
...4	CN74	CJP05GB03ZY	WAFER , ANGLE (2.5mm)		1
...4	C411	CCEA1JH101E	CAP , ELECT	100UF 63V	1
...4	D101	CVD1L0345W31BOCT201W	L.E.D , WHITE		1
...4	D102	CVD30ASOGCAA-S7	L.E.D , ORANGE	T0L-30ASOGCAA-S7	1
...4	D201	CVD1L0345W31BOCT201W	L.E.D , WHITE		1
...4	D202	CVD1L0345W31BOCT201W	L.E.D , WHITE		1
...4	D203	CVD1L0345W31BOCT201W	L.E.D , WHITE		1



FRONT PCB ASSY					
Level	Ref. #	Part Number	Description	Drawing No (Value)	Qty
...4	ET63	CMC2A325	PLATE , EARTH AVR155		1
...4	ET64	CMC4A111	PLATE , EARTH		1
...4	FB13	KLZ9H001Z	BEAD , CORE		1
...4	FB14	KLZ9H001Z	BEAD , CORE		1
...4	FB15	KLZ9H001Z	BEAD , CORE		1
...4	F1	CFL162BD01GINK	V.F.D	162-BD-01GINK	1
...4	IC11	HVI74HCU04AFNG	I.C , INVERTER (TOSHIBA)	TC74HCU04AFNG(TOSHI	1
...4	IC12	HRVNJL34H380A	SENSOR , REMOCON (JRC)		1
...4	IC13	HVI74ACT04MTR	I.C , HEX (ST)		1
...4	IC14	HVINJM2068MTE1	I.C , OP AMP (JRC)	NJM2068M-TE1	1
...4	IC15	HVINJM4556AL	I.C , HEADPHONE (JRC)	NJM4556AL	1
...4	JK51	CJJ9X006Z	JACK , USB STRAIGHT(BLACK)	U250FD004BY	1
...4	JK52	CJJ4S028Y	JACK , BOARD (3P SILVER)		1
...4	JK61	CJJ4M041Y	JACK , BOARD (COAX)		1
...4	JK62	HJSTORX177L	MODULE , OPTICAL(RX)	TORX177L	1
...4	JK63	CJJ2E026Z	JACK , HEADPHONE(SILVER PLATE)		1
...4	RL91	CSL4A016ZU	RELAY , 12V 2C2P	BC3-12H	1
...4	VR74	CSR2A037Z	ENCODER		1
MAIN PCB ASSY					
Level	Ref. #	Part Number	Description	Drawing No (Value)	Qty
..3		<b>COP12170E</b>	<b>AVR160 MAIN PCB ASS'Y</b>		<b>1</b>
...4		CIP12170E	AVR160 MAIN PCB AUTO ASS'Y		1
...5		CUP12170X	PCB , MAIN AVR1600 (330X247, FR1)		1
...5	C501	CCEA1HH100T	CAP , ELECT	10UF 50V	1
...5	C502	CCEA1HH100T	CAP , ELECT	10UF 50V	1
...5	C503	CCEA1HH100T	CAP , ELECT	10UF 50V	1
...5	C504	CCEA1HH100T	CAP , ELECT	10UF 50V	1
...5	C505	CCEA1HH100T	CAP , ELECT	10UF 50V	1
...5	C506	CCKT1H331KB	CAP , CERAMIC	330PF 50V K	1
...5	C507	CCBS1H331KBT	CAP , CERAMIC(330PF/50V)	CH UP025 B331K-A-B Z	1
...5	C508	CCBS1H331KBT	CAP , CERAMIC(330PF/50V)	CH UP025 B331K-A-B Z	1
...5	C509	CCKT1H331KB	CAP , CERAMIC	330PF 50V K	1
...5	C510	CCBS1H331KBT	CAP , CERAMIC(330PF/50V)	CH UP025 B331K-A-B Z	1
...5	C561	CCEA1CH101T	CAP , ELECT	100UF 16V	1
...5	C562	CCEA1CH101T	CAP , ELECT	100UF 16V	1
...5	C563	CCEA1CH101T	CAP , ELECT	100UF 16V	1
...5	C564	CCEA1CH101T	CAP , ELECT	100UF 16V	1
...5	C565	CCEA1CH101T	CAP , ELECT	100UF 16V	1
...5	C566	CCEA1CH101T	CAP , ELECT	100UF 16V	1
...5	C567	CCEA1CH101T	CAP , ELECT	100UF 16V	1
...5	C568	CCEA1CH101T	CAP , ELECT	100UF 16V	1
...5	C569	CCEA1CH101T	CAP , ELECT	100UF 16V	1
...5	C570	CCEA1CH101T	CAP , ELECT	100UF 16V	1
...5	C571	CCBS1H681KBT	CAP , CERAMIC(680PF/50V)	CH UP025 B681K-A-B Z	1
...5	C572	CCBS1H681KBT	CAP , CERAMIC(680PF/50V)	CH UP025 B681K-A-B Z	1
...5	C573	CCBS1H681KBT	CAP , CERAMIC(680PF/50V)	CH UP025 B681K-A-B Z	1
...5	C574	CCBS1H681KBT	CAP , CERAMIC(680PF/50V)	CH UP025 B681K-A-B Z	1
...5	C575	CCBS1H681KBT	CAP , CERAMIC(680PF/50V)	CH UP025 B681K-A-B Z	1
...5	C601	CCCT1H120JC	CAP , CERAMIC	12PF 50V J	1
...5	C602	CCCT1H120JC	CAP , CERAMIC	12PF 50V J	1
...5	C603	CCCT1H120JC	CAP , CERAMIC	12PF 50V J	1
...5	C604	CCCT1H120JC	CAP , CERAMIC	12PF 50V J	1
...5	C605	CCCT1H120JC	CAP , CERAMIC	12PF 50V J	1
...5	C606	CCCT1H330JC	CAP , CERAMIC	33PF 50V J	1
...5	C607	CCCT1H330JC	CAP , CERAMIC	33PF 50V J	1
...5	C608	CCCT1H330JC	CAP , CERAMIC	33PF 50V J	1
...5	C609	CCCT1H330JC	CAP , CERAMIC	33PF 50V J	1
...5	C610	CCCT1H330JC	CAP , CERAMIC	33PF 50V J	1
...5	C681	CCEA1HH100T	CAP , ELECT	10UF 50V	1
...5	C682	CCEA1HH100T	CAP , ELECT	10UF 50V	1
...5	C683	CCEA1HH100T	CAP , ELECT	10UF 50V	1
...5	C684	CCEA1HH100T	CAP , ELECT	10UF 50V	1
...5	C685	CCEA1HH100T	CAP , ELECT	10UF 50V	1
...5	C726	CCKT1H221KB	CAP , CERAMIC	220PF 50V K	1
...5	C801	CCEA1HH100T	CAP , ELECT	10UF 50V	1
...5	C802	CCEA1HH100T	CAP , ELECT	10UF 50V	1
...5	C803	CCCT1H330JC	CAP , CERAMIC	33PF 50V J	1
...5	C804	CCCT1H330JC	CAP , CERAMIC	33PF 50V J	1
...5	C805	CCCT1H120JC	CAP , CERAMIC	12PF 50V J	1
...5	C806	CCCT1H120JC	CAP , CERAMIC	12PF 50V J	1
...5	C811	CCEA1CH101T	CAP , ELECT	100UF 16V	1
...5	C812	CCEA1CH101T	CAP , ELECT	100UF 16V	1
...5	C813	CCEA1CH101T	CAP , ELECT	100UF 16V	1
...5	C814	CCEA1CH101T	CAP , ELECT	100UF 16V	1
...5	C815	CCKT1H331KB	CAP , CERAMIC	330PF 50V K	1
...5	C816	CCBS1H331KBT	CAP , CERAMIC(330PF/50V)	CH UP025 B331K-A-B Z	1
...5	C817	CCEA1HH100T	CAP , ELECT	10UF 50V	1

MAIN PCB ASSY					
Level	Ref. #	Part Number	Description	Drawing No (Value)	Qty
....5	C818	CCEA1HH100T	CAP , ELECT	10UF 50V	1
....5	C819	CCBS1H681KBT	CAP , CERAMIC(680PF/50V)	CH UP025 B681K-A-B Z	1
....5	C820	CCBS1H681KBT	CAP , CERAMIC(680PF/50V)	CH UP025 B681K-A-B Z	1
....5	C851	CCEA1HH100T	CAP , ELECT	10UF 50V	1
....5	C852	CCEA1HH100T	CAP , ELECT	10UF 50V	1
....5	C853	CCEA1HH100T	CAP , ELECT	10UF 50V	1
....5	C854	CCEA1HH100T	CAP , ELECT	10UF 50V	1
....5	C855	CCEA1HH100T	CAP , ELECT	10UF 50V	1
....5	C856	CCEA1HH100T	CAP , ELECT	10UF 50V	1
....5	C857	CCEA1HH100T	CAP , ELECT	10UF 50V	1
....5	C900	HCQI1H473JZT	CAP , MYLAR	0.047UF 50V J	1
....5	C901	HCQI1H473JZT	CAP , MYLAR	0.047UF 50V J	1
....5	C905	CCBS1H223ZFT	CAP , CERAMIC(22000PF/50V)	CH UP025 F223Z-A-B J	1
....5	C907	CCEA1CH101T	CAP , ELECT	100UF 16V	1
....5	C908	CCBS1H223ZFT	CAP , CERAMIC(22000PF/50V)	CH UP025 F223Z-A-B J	1
....5	C910	HCQI1H473JZT	CAP , MYLAR	0.047UF 50V J	1
....5	C911	CCEA1CH471T	CAP , ELECT	470UF 16V	1
....5	C912	CCEA1CH221T	CAP , ELECT	220UF 16V	1
....5	C913	CCFT1H104ZF	CAP , SEMICONDUCTOR	0.1UF 50V Z	1
....5	C914	HCQI1H473JZT	CAP , MYLAR	0.047UF 50V J	1
....5	C917	HCQI1H473JZT	CAP , MYLAR	0.047UF 50V J	1
....5	C918	HCQI1H473JZT	CAP , MYLAR	0.047UF 50V J	1
....5	C919	HCQI1H473JZT	CAP , MYLAR	0.047UF 50V J	1
....5	C924	CCFT1H104ZF	CAP , SEMICONDUCTOR	0.1UF 50V Z	1
....5	C932	CCEA1CH101T	CAP , ELECT	100UF 16V	1
....5	C933	CCEA1EH221T	CAP , ELECT	220UF 25V	1
....5	C934	CCFT1H223ZF	CAP , CERAMIC	0.022UF 50V Z	1
....5	C936	CCEA1EH221T	CAP , ELECT	220UF 25V	1
....5	C939	CCEA1HH4R7T	CAP , ELECT	4.7UF 50V	1
....5	C940	CCEA1AH471T	CAP , ELECT	470UF 10V	1
....5	C948	CCBS1H104ZFT	CAP , CERAMIC	0.1UF 50V Z	1
....5	C950	CCEA1AH471T	CAP , ELECT	470UF 10V	1
....5	C971	HCQI1H562JZT	CAP , MYLAR	5600PF 50V J	1
....5	C972	HCQI1H562JZT	CAP , MYLAR	5600PF 50V J	1
....5	C973	HCQI1H562JZT	CAP , MYLAR	5600PF 50V J	1
....5	C974	HCQI1H562JZT	CAP , MYLAR	5600PF 50V J	1
....5	C975	HCQI1H562JZT	CAP , MYLAR	5600PF 50V J	1
....5	C977	CCEA1HH4R7T	CAP , ELECT	4.7UF 50V	1
....5	C980	HCQI1H562JZT	CAP , MYLAR	5600PF 50V J	1
....5	C981	HCQI1H562JZT	CAP , MYLAR	5600PF 50V J	1
....5	C990	HCQI1H473JZT	CAP , MYLAR	0.047UF 50V J	1
....5	C991	CCEA1HH1R0T	CAP , ELECT	1UF 50V	1
....5	C992	HCQI1H473JZT	CAP , MYLAR	0.047UF 50V J	1
....5	C993	HCQI1H473JZT	CAP , MYLAR	0.047UF 50V J	1
....5	C994	HCQI1H473JZT	CAP , MYLAR	0.047UF 50V J	1
....5	C995	HCQI1H473JZT	CAP , MYLAR	0.047UF 50V J	1
....5	C996	HCQI1H473JZT	CAP , MYLAR	0.047UF 50V J	1
....5	C997	HCQI1H473JZT	CAP , MYLAR	0.047UF 50V J	1
....5	C999	CCBS1H223ZFT	CAP , CERAMIC(22000PF/50V)	CH UP025 F223Z-A-B J	1
....5	D501	HVD1SS133MT	DIODE	1SS133T-77	1
....5	D502	HVD1SS133MT	DIODE	1SS133T-77	1
....5	D503	HVD1SS133MT	DIODE	1SS133T-77	1
....5	D504	HVD1SS133MT	DIODE	1SS133T-77	1
....5	D505	HVD1SS133MT	DIODE	1SS133T-77	1
....5	D581	HVD1SS133MT	DIODE	1SS133T-77	1
....5	D582	HVD1SS133MT	DIODE	1SS133T-77	1
....5	D583	HVD1SS133MT	DIODE	1SS133T-77	1
....5	D584	HVD1SS133MT	DIODE	1SS133T-77	1
....5	D585	HVD1SS133MT	DIODE	1SS133T-77	1
....5	D801	HVD1SS133MT	DIODE	1SS133T-77	1
....5	D802	HVD1SS133MT	DIODE	1SS133T-77	1
....5	D803	HVD1SS133MT	DIODE	1SS133T-77	1
....5	D804	HVD1SS133MT	DIODE	1SS133T-77	1
....5	D901	HVD1N5819T	DIODE , SCHOTTKY	1N5819	1
....5	D902	HVD1SS133MT	DIODE	1SS133T-77	1
....5	D911	HVD1SS133MT	DIODE	1SS133T-77	1
....5	D912	HVD1SS133MT	DIODE	1SS133T-77	1
....5	D914	C3A206	WIRE , COPPER	SN95/PB5 , 0.6	0,018
....5	D917	HVD1SS133MT	DIODE	1SS133T-77	1
....5	D953	HVD1SS133MT	DIODE	1SS133T-77	1
....5	D954	CVD1N4003SRT	DIODE , RECT	1N4003	1
....5	D955	CVD1N4003SRT	DIODE , RECT	1N4003	1
....5	D956	CVD1N4003SRT	DIODE , RECT	1N4003	1
....5	D957	CVD1N4003SRT	DIODE , RECT	1N4003	1
....5	D961	HVD1N5819T	DIODE , SCHOTTKY	1N5819	1
....5	D962	CVD1N4003SRT	DIODE , RECT	1N4003	1
....5	D963	CVD1N4003SRT	DIODE , RECT	1N4003	1
....5	D964	HVD1SS133MT	DIODE	1SS133T-77	1
....5	D967	HVD1SS133MT	DIODE	1SS133T-77	1



MAIN PCB ASSY					
Level	Ref. #	Part Number	Description	Drawing No (Value)	Qty
....5	D968	HVD1SS133MT	DIODE	1SS133T-77	1
....5	D969	HVD1SS133MT	DIODE	1SS133T-77	1
....5	D973	HVD1SS133MT	DIODE	1SS133T-77	1
....5	D974	HVD1SS133MT	DIODE	1SS133T-77	1
....5	D975	HVD1SS133MT	DIODE	1SS133T-77	1
....5	D976	HVD1SS133MT	DIODE	1SS133T-77	1
....5	D979	HVDMTZJ5.1BT	DIODE , ZENER	MTZJ5.1B 1/2W	1
....5	ET90	HJT1A025	PALTE , EARTH	MET37-0002	1
....5	ET91	HJT1A025	PALTE , EARTH	MET37-0002	1
....5	F901	KJCF5S	HOLDER , FUSE		2
....5	IC97	HVIRE5VT28CATZ	I.C , RESET (RICOH)		1
....5	Q501	HVTKTA1268GRT	T.R	KTA1268GR	1
....5	Q502	HVTKTA1268GRT	T.R	KTA1268GR	1
....5	Q503	HVTKTA1268GRT	T.R	KTA1268GR	1
....5	Q504	HVTKTA1268GRT	T.R	KTA1268GR	1
....5	Q505	HVTKTA1268GRT	T.R	KTA1268GR	1
....5	Q511	HVTKTC3200GRT	T.R	KTC3200GR	1
....5	Q512	HVTKTC3200GRT	T.R	KTC3200GR	1
....5	Q513	HVTKTC3200GRT	T.R	KTC3200GR	1
....5	Q514	HVTKTC3200GRT	T.R	KTC3200GR	1
....5	Q515	HVTKTC3200GRT	T.R	KTC3200GR	1
....5	Q516	HVTKTC3200GRT	T.R	KTC3200GR	1
....5	Q517	HVTKTC3200GRT	T.R	KTC3200GR	1
....5	Q518	HVTKTC3200GRT	T.R	KTC3200GR	1
....5	Q519	HVTKTC3200GRT	T.R	KTC3200GR	1
....5	Q520	HVTKTC3200GRT	T.R	KTC3200GR	1
....5	Q541	HVTKTC3198YT	T.R	KTC3198Y	1
....5	Q542	HVTKTC3198YT	T.R	KTC3198Y	1
....5	Q543	HVTKTC3198YT	T.R	KTC3198Y	1
....5	Q544	HVTKTC3198YT	T.R	KTC3198Y	1
....5	Q545	HVTKTC3198YT	T.R	KTC3198Y	1
....5	Q556	HVTKTC3200GRT	T.R	KTC3200GR	1
....5	Q557	HVTKTC3200GRT	T.R	KTC3200GR	1
....5	Q558	HVTKTC3200GRT	T.R	KTC3200GR	1
....5	Q559	HVTKTC3200GRT	T.R	KTC3200GR	1
....5	Q560	HVTKTC3200GRT	T.R	KTC3200GR	1
....5	Q561	HVTKTC3200GRT	T.R	KTC3200GR	1
....5	Q562	HVTKTC3200GRT	T.R	KTC3200GR	1
....5	Q563	HVTKTC3200GRT	T.R	KTC3200GR	1
....5	Q564	HVTKTC3200GRT	T.R	KTC3200GR	1
....5	Q565	HVTKTC3200GRT	T.R	KTC3200GR	1
....5	Q601	HVTKTA1268GRT	T.R	KTA1268GR	1
....5	Q602	HVTKTA1268GRT	T.R	KTA1268GR	1
....5	Q603	HVTKTA1268GRT	T.R	KTA1268GR	1
....5	Q604	HVTKTA1268GRT	T.R	KTA1268GR	1
....5	Q605	HVTKTA1268GRT	T.R	KTA1268GR	1
....5	Q681	HVTKTC3199YT	T.R	KTC3199Y	1
....5	Q682	HVTKTC3199YT	T.R	KTC3199Y	1
....5	Q683	HVTKTC3199YT	T.R	KTC3199Y	1
....5	Q684	HVTKTC3199YT	T.R	KTC3199Y	1
....5	Q685	HVTKTC3199YT	T.R	KTC3199Y	1
....5	Q801	HVTKTC3199YT	T.R	KTC3199Y	1
....5	Q802	HVTKTC3199YT	T.R	KTC3199Y	1
....5	Q812	HVTKTA1268GRT	T.R	KTA1268GR	1
....5	Q813	HVTKTC3200GRT	T.R	KTC3200GR	1
....5	Q814	HVTKTA1268GRT	T.R	KTA1268GR	1
....5	Q815	HVTKTC3200GRT	T.R	KTC3200GR	1
....5	Q816	HVTKTA1268GRT	T.R	KTA1268GR	1
....5	Q817	HVTKTA1268GRT	T.R	KTA1268GR	1
....5	Q818	HVTKTC3200GRT	T.R	KTC3200GR	1
....5	Q819	HVTKTC3200GRT	T.R	KTC3200GR	1
....5	Q820	HVTKTC3200GRT	T.R	KTC3200GR	1
....5	Q821	HVTKTC3200GRT	T.R	KTC3200GR	1
....5	Q822	HVTKTC3200GRT	T.R	KTC3200GR	1
....5	Q823	HVTKTC3200GRT	T.R	KTC3200GR	1
....5	Q824	HVTKTC3198YT	T.R	KTC3198Y	1
....5	Q825	HVTKTC3198YT	T.R	KTC3198Y	1
....5	Q901	HVTKTC3199YT	T.R	KTC3199Y	1
....5	Q911	HVTKTA1271YT	T.R	KTA1271Y	1
....5	Q912	HVTKTA1271YT	T.R	KTA1271Y	1
....5	Q913	HVTKTA1271YT	T.R	KTA1271Y	1
....5	Q914	HVTKTA1271YT	T.R	KTA1271Y	1
....5	Q915	HVTKTC3199YT	T.R	KTC3199Y	1
....5	Q916	HVTKRC107MT	T.R	KRC107M	1
....5	Q917	HVTKRC107MT	T.R	KRC107M	1
....5	Q918	HVTKRC107MT	T.R	KRC107M	1
....5	Q938	HVTKRA107MT	T.R	KRA107M	1
....5	Q939	HVTKRA107MT	T.R	KRA107M	1
....5	Q941	HVTKTC3199YT	T.R	KTC3199Y	1

MAIN PCB ASSY					
Level	Ref. #	Part Number	Description	Drawing No (Value)	Qty
....5	Q942	HVTKTC3199YT	T.R	KTC3199Y	1
....5	Q943	HVTKTC3199YT	T.R	KTC3199Y	1
....5	Q960	HVTKRC107MT	T.R	KRC107M	1
....5	Q961	HVTKTA1024YT	T.R		1
....5	R500	CRD20TJ103T	RES, CARBON	10K OHM 1/5W J	1
....5	R501	CRD20TJ433T	RES, CARBON	43K OHM 1/5W J	1
....5	R502	CRD20TJ433T	RES, CARBON	43K OHM 1/5W J	1
....5	R503	CRD20TJ433T	RES, CARBON	43K OHM 1/5W J	1
....5	R504	CRD20TJ433T	RES, CARBON	43K OHM 1/5W J	1
....5	R505	CRD20TJ433T	RES, CARBON	43K OHM 1/5W J	1
....5	R506	CRD20TJ333T	RES, CARBON	33K OHM 1/5W J	1
....5	R507	CRD20TJ333T	RES, CARBON	33K OHM 1/5W J	1
....5	R508	CRD20TJ333T	RES, CARBON	33K OHM 1/5W J	1
....5	R509	CRD20TJ333T	RES, CARBON	33K OHM 1/5W J	1
....5	R510	CRD20TJ333T	RES, CARBON	33K OHM 1/5W J	1
....5	R511	CRD20TJ152T	RES, CARBON	1.5K OHM 1/5W J	1
....5	R512	CRD20TJ152T	RES, CARBON	1.5K OHM 1/5W J	1
....5	R513	CRD20TJ152T	RES, CARBON	1.5K OHM 1/5W J	1
....5	R514	CRD20TJ152T	RES, CARBON	1.5K OHM 1/5W J	1
....5	R515	CRD20TJ152T	RES, CARBON	1.5K OHM 1/5W J	1
....5	R516	CRD20TJ152T	RES, CARBON	1.5K OHM 1/5W J	1
....5	R517	CRD20TJ152T	RES, CARBON	1.5K OHM 1/5W J	1
....5	R518	CRD20TJ152T	RES, CARBON	1.5K OHM 1/5W J	1
....5	R519	CRD20TJ152T	RES, CARBON	1.5K OHM 1/5W J	1
....5	R520	CRD20TJ152T	RES, CARBON	1.5K OHM 1/5W J	1
....5	R521	CRD20TJ471T	RES, CARBON	470 OHM 1/5W J	1
....5	R522	CRD20TJ471T	RES, CARBON	470 OHM 1/5W J	1
....5	R523	CRD20TJ471T	RES, CARBON	470 OHM 1/5W J	1
....5	R524	CRD20TJ471T	RES, CARBON	470 OHM 1/5W J	1
....5	R525	CRD20TJ471T	RES, CARBON	470 OHM 1/5W J	1
....5	R531	CRD20TJ221T	RES, CARBON	220 OHM 1/5W J	1
....5	R532	CRD20TJ221T	RES, CARBON	220 OHM 1/5W J	1
....5	R533	CRD20TJ221T	RES, CARBON	220 OHM 1/5W J	1
....5	R534	CRD20TJ221T	RES, CARBON	220 OHM 1/5W J	1
....5	R535	CRD20TJ221T	RES, CARBON	220 OHM 1/5W J	1
....5	R536	CRD20TJ221T	RES, CARBON	220 OHM 1/5W J	1
....5	R537	CRD20TJ221T	RES, CARBON	220 OHM 1/5W J	1
....5	R538	CRD20TJ221T	RES, CARBON	220 OHM 1/5W J	1
....5	R539	CRD20TJ221T	RES, CARBON	220 OHM 1/5W J	1
....5	R540	CRD20TJ221T	RES, CARBON	220 OHM 1/5W J	1
....5	R541	CRD20TJ271T	RES, CARBON	270 OHM 1/5W J	1
....5	R542	CRD20TJ271T	RES, CARBON	270 OHM 1/5W J	1
....5	R543	CRD20TJ271T	RES, CARBON	270 OHM 1/5W J	1
....5	R544	CRD20TJ271T	RES, CARBON	270 OHM 1/5W J	1
....5	R545	CRD20TJ271T	RES, CARBON	270 OHM 1/5W J	1
....5	R556	CRD20TJ273T	RES, CARBON	27K OHM 1/5W J	1
....5	R557	CRD20TJ273T	RES, CARBON	27K OHM 1/5W J	1
....5	R558	CRD20TJ273T	RES, CARBON	27K OHM 1/5W J	1
....5	R559	CRD20TJ273T	RES, CARBON	27K OHM 1/5W J	1
....5	R560	CRD20TJ273T	RES, CARBON	27K OHM 1/5W J	1
....5	R561	CRD20TJ182T	RES, CARBON	1.8K OHM 1/5W J	1
....5	R562	CRD20TJ182T	RES, CARBON	1.8K OHM 1/5W J	1
....5	R563	CRD20TJ182T	RES, CARBON	1.8K OHM 1/5W J	1
....5	R564	CRD20TJ182T	RES, CARBON	1.8K OHM 1/5W J	1
....5	R565	CRD20TJ182T	RES, CARBON	1.8K OHM 1/5W J	1
....5	R566	CRD20TJ561T	RES, CARBON	560 OHM 1/5W J	1
....5	R567	CRD20TJ561T	RES, CARBON	560 OHM 1/5W J	1
....5	R568	CRD20TJ561T	RES, CARBON	560 OHM 1/5W J	1
....5	R569	CRD20TJ561T	RES, CARBON	560 OHM 1/5W J	1
....5	R570	CRD20TJ561T	RES, CARBON	560 OHM 1/5W J	1
....5	R571	CRD20TJ561T	RES, CARBON	560 OHM 1/5W J	1
....5	R572	CRD20TJ561T	RES, CARBON	560 OHM 1/5W J	1
....5	R573	CRD20TJ561T	RES, CARBON	560 OHM 1/5W J	1
....5	R574	CRD20TJ561T	RES, CARBON	560 OHM 1/5W J	1
....5	R575	CRD20TJ561T	RES, CARBON	560 OHM 1/5W J	1
....5	R576	CRD20TJ100T	RES, CARBON	10 OHM 1/5W J	1
....5	R577	CRD20TJ100T	RES, CARBON	10 OHM 1/5W J	1
....5	R578	CRD20TJ100T	RES, CARBON	10 OHM 1/5W J	1
....5	R579	CRD20TJ100T	RES, CARBON	10 OHM 1/5W J	1
....5	R580	CRD20TJ100T	RES, CARBON	10 OHM 1/5W J	1
....5	R581	CRD20TJ561T	RES, CARBON	560 OHM 1/5W J	1
....5	R582	CRD20TJ561T	RES, CARBON	560 OHM 1/5W J	1
....5	R583	CRD20TJ561T	RES, CARBON	560 OHM 1/5W J	1
....5	R584	CRD20TJ561T	RES, CARBON	560 OHM 1/5W J	1
....5	R585	CRD20TJ561T	RES, CARBON	560 OHM 1/5W J	1
....5	R586	CRD20TJ561T	RES, CARBON	560 OHM 1/5W J	1
....5	R587	CRD20TJ561T	RES, CARBON	560 OHM 1/5W J	1
....5	R588	CRD20TJ561T	RES, CARBON	560 OHM 1/5W J	1
....5	R589	CRD20TJ561T	RES, CARBON	560 OHM 1/5W J	1

MAIN PCB ASSY					
Level	Ref. #	Part Number	Description	Drawing No (Value)	Qty
....5	R590	CRD20TJ561T	RES, CARBON	560 OHM 1/5W J	1
....5	R591	CRD20TJ561T	RES, CARBON	560 OHM 1/5W J	1
....5	R592	CRD20TJ561T	RES, CARBON	560 OHM 1/5W J	1
....5	R593	CRD20TJ561T	RES, CARBON	560 OHM 1/5W J	1
....5	R594	CRD20TJ561T	RES, CARBON	560 OHM 1/5W J	1
....5	R595	CRD20TJ561T	RES, CARBON	560 OHM 1/5W J	1
....5	R596	CRD20TJ561T	RES, CARBON	560 OHM 1/5W J	1
....5	R597	CRD20TJ561T	RES, CARBON	560 OHM 1/5W J	1
....5	R598	CRD20TJ561T	RES, CARBON	560 OHM 1/5W J	1
....5	R599	CRD20TJ561T	RES, CARBON	560 OHM 1/5W J	1
....5	R600	CRD20TJ561T	RES, CARBON	560 OHM 1/5W J	1
....5	R601	CRD20TJ223T	RES, CARBON	22K OHM 1/5W J	1
....5	R602	CRD20TJ223T	RES, CARBON	22K OHM 1/5W J	1
....5	R603	CRD20TJ223T	RES, CARBON	22K OHM 1/5W J	1
....5	R604	CRD20TJ223T	RES, CARBON	22K OHM 1/5W J	1
....5	R605	CRD20TJ223T	RES, CARBON	22K OHM 1/5W J	1
....5	R606	CRD20TJ223T	RES, CARBON	22K OHM 1/5W J	1
....5	R607	CRD20TJ223T	RES, CARBON	22K OHM 1/5W J	1
....5	R608	CRD20TJ223T	RES, CARBON	22K OHM 1/5W J	1
....5	R609	CRD20TJ223T	RES, CARBON	22K OHM 1/5W J	1
....5	R610	CRD20TJ223T	RES, CARBON	22K OHM 1/5W J	1
....5	R611	CRD20TJ100T	RES, CARBON	10 OHM 1/5W J	1
....5	R612	CRD20TJ100T	RES, CARBON	10 OHM 1/5W J	1
....5	R631	CRD25FJ180T	RES, CARBON (18 OHM) NONFLAMMABLE		1
....5	R632	CRD25FJ180T	RES, CARBON (18 OHM) NONFLAMMABLE		1
....5	R633	CRD25FJ180T	RES, CARBON (18 OHM) NONFLAMMABLE		1
....5	R634	CRD25FJ180T	RES, CARBON (18 OHM) NONFLAMMABLE		1
....5	R635	CRD25FJ180T	RES, CARBON (18 OHM) NONFLAMMABLE		1
....5	R636	CRD25FJ180T	RES, CARBON (18 OHM) NONFLAMMABLE		1
....5	R637	CRD25FJ180T	RES, CARBON (18 OHM) NONFLAMMABLE		1
....5	R638	CRD25FJ180T	RES, CARBON (18 OHM) NONFLAMMABLE		1
....5	R639	CRD25FJ180T	RES, CARBON (18 OHM) NONFLAMMABLE		1
....5	R640	CRD25FJ180T	RES, CARBON (18 OHM) NONFLAMMABLE		1
....5	R646	CRD25FJ3R3T	RES, CARBON	3.3 OHM 1/4W J	1
....5	R647	CRD25FJ3R3T	RES, CARBON	3.3 OHM 1/4W J	1
....5	R648	CRD25FJ3R3T	RES, CARBON	3.3 OHM 1/4W J	1
....5	R649	CRD25FJ3R3T	RES, CARBON	3.3 OHM 1/4W J	1
....5	R650	CRD25FJ3R3T	RES, CARBON	3.3 OHM 1/4W J	1
....5	R651	CRD25FJ3R3T	RES, CARBON	3.3 OHM 1/4W J	1
....5	R652	CRD25FJ3R3T	RES, CARBON	3.3 OHM 1/4W J	1
....5	R653	CRD25FJ3R3T	RES, CARBON	3.3 OHM 1/4W J	1
....5	R654	CRD25FJ3R3T	RES, CARBON	3.3 OHM 1/4W J	1
....5	R655	CRD25FJ3R3T	RES, CARBON	3.3 OHM 1/4W J	1
....5	R666	CRD25TJ470T	RES, CARBON (47 OHM)		1
....5	R667	CRD25TJ470T	RES, CARBON (47 OHM)		1
....5	R668	CRD25TJ470T	RES, CARBON (47 OHM)		1
....5	R669	CRD25TJ470T	RES, CARBON (47 OHM)		1
....5	R670	CRD25TJ470T	RES, CARBON (47 OHM)		1
....5	R671	CRD20TJ472T	RES, CARBON	4.7K OHM 1/5W J	1
....5	R672	CRD20TJ472T	RES, CARBON	4.7K OHM 1/5W J	1
....5	R673	CRD20TJ472T	RES, CARBON	4.7K OHM 1/5W J	1
....5	R674	CRD20TJ472T	RES, CARBON	4.7K OHM 1/5W J	1
....5	R675	CRD20TJ472T	RES, CARBON	4.7K OHM 1/5W J	1
....5	R676	CRD25TJ182T	RES, CARBON (1.8K OHM)		1
....5	R677	CRD25TJ182T	RES, CARBON (1.8K OHM)		1
....5	R678	CRD25TJ182T	RES, CARBON (1.8K OHM)		1
....5	R679	CRD25TJ182T	RES, CARBON (1.8K OHM)		1
....5	R680	CRD25TJ182T	RES, CARBON (1.8K OHM)		1
....5	R681	CRD20TJ562T	RES, CARBON	5.6K OHM 1/5W J	1
....5	R682	CRD20TJ562T	RES, CARBON	5.6K OHM 1/5W J	1
....5	R683	CRD20TJ562T	RES, CARBON	5.6K OHM 1/5W J	1
....5	R684	CRD20TJ562T	RES, CARBON	5.6K OHM 1/5W J	1
....5	R685	CRD20TJ562T	RES, CARBON	5.6K OHM 1/5W J	1
....5	R686	CRD20TJ103T	RES, CARBON	10K OHM 1/5W J	1
....5	R687	CRD20TJ103T	RES, CARBON	10K OHM 1/5W J	1
....5	R688	CRD20TJ103T	RES, CARBON	10K OHM 1/5W J	1
....5	R689	CRD20TJ103T	RES, CARBON	10K OHM 1/5W J	1
....5	R690	CRD20TJ103T	RES, CARBON	10K OHM 1/5W J	1
....5	R696	CRD25TJ470T	RES, CARBON (47 OHM)		1
....5	R697	CRD25TJ470T	RES, CARBON (47 OHM)		1
....5	R698	CRD25TJ470T	RES, CARBON (47 OHM)		1
....5	R699	CRD25TJ470T	RES, CARBON (47 OHM)		1
....5	R700	CRD25TJ470T	RES, CARBON (47 OHM)		1
....5	R771	CRD20TJ750T	RES, CARBON	75 OHM 1/5W J	1
....5	R772	CRD20TJ750T	RES, CARBON	75 OHM 1/5W J	1
....5	R773	CRD20TJ750T	RES, CARBON	75 OHM 1/5W J	1
....5	R774	CRD20TJ750T	RES, CARBON	75 OHM 1/5W J	1
....5	R775	CRD20TJ750T	RES, CARBON	75 OHM 1/5W J	1
....5	R776	CRD20TJ750T	RES, CARBON	75 OHM 1/5W J	1

MAIN PCB ASSY					
Level	Ref. #	Part Number	Description	Drawing No (Value)	Qty
....5	R777	CRD20TJ750T	RES, CARBON	75 OHM 1/5W J	1
....5	R781	CRD20TJ750T	RES, CARBON	75 OHM 1/5W J	1
....5	R782	CRD20TJ750T	RES, CARBON	75 OHM 1/5W J	1
....5	R783	CRD20TJ750T	RES, CARBON	75 OHM 1/5W J	1
....5	R784	CRD20TJ750T	RES, CARBON	75 OHM 1/5W J	1
....5	R785	CRD20TJ750T	RES, CARBON	75 OHM 1/5W J	1
....5	R786	CRD20TJ750T	RES, CARBON	75 OHM 1/5W J	1
....5	R787	CRD20TJ750T	RES, CARBON	75 OHM 1/5W J	1
....5	R801	CRD20TJ103T	RES, CARBON	10K OHM 1/5W J	1
....5	R802	CRD20TJ103T	RES, CARBON	10K OHM 1/5W J	1
....5	R803	CRD20TJ562T	RES, CARBON	5.6K OHM 1/5W J	1
....5	R804	CRD20TJ562T	RES, CARBON	5.6K OHM 1/5W J	1
....5	R805	CRD20TJ472T	RES, CARBON	4.7K OHM 1/5W J	1
....5	R807	CRD20TJ472T	RES, CARBON	4.7K OHM 1/5W J	1
....5	R808	CRD25TJ182T	RES, CARBON (1.8K OHM)		1
....5	R809	CRD25TJ182T	RES, CARBON (1.8K OHM)		1
....5	R812	CRD25TJ470T	RES, CARBON (47 OHM)		1
....5	R813	CRD25TJ470T	RES, CARBON (47 OHM)		1
....5	R814	CRD25TJ470T	RES, CARBON (47 OHM)		1
....5	R815	CRD25TJ470T	RES, CARBON (47 OHM)		1
....5	R817	CRD25FJ3R3T	RES, CARBON	3.3 OHM 1/4W J	1
....5	R818	CRD25FJ3R3T	RES, CARBON	3.3 OHM 1/4W J	1
....5	R819	CRD25FJ3R3T	RES, CARBON	3.3 OHM 1/4W J	1
....5	R820	CRD25FJ3R3T	RES, CARBON	3.3 OHM 1/4W J	1
....5	R821	CRD25FJ180T	RES, CARBON (18 OHM) NONFLAMMABLE		1
....5	R822	CRD25FJ180T	RES, CARBON (18 OHM) NONFLAMMABLE		1
....5	R823	CRD25FJ180T	RES, CARBON (18 OHM) NONFLAMMABLE		1
....5	R824	CRD25FJ180T	RES, CARBON (18 OHM) NONFLAMMABLE		1
....5	R830	CRD20TJ223T	RES, CARBON	22K OHM 1/5W J	1
....5	R831	CRD20TJ223T	RES, CARBON	22K OHM 1/5W J	1
....5	R832	CRD20TJ223T	RES, CARBON	22K OHM 1/5W J	1
....5	R833	CRD20TJ223T	RES, CARBON	22K OHM 1/5W J	1
....5	R834	CRD20TJ561T	RES, CARBON	560 OHM 1/5W J	1
....5	R835	CRD20TJ561T	RES, CARBON	560 OHM 1/5W J	1
....5	R836	CRD20TJ561T	RES, CARBON	560 OHM 1/5W J	1
....5	R837	CRD20TJ561T	RES, CARBON	560 OHM 1/5W J	1
....5	R838	CRD20TJ561T	RES, CARBON	560 OHM 1/5W J	1
....5	R839	CRD20TJ561T	RES, CARBON	560 OHM 1/5W J	1
....5	R840	CRD20TJ561T	RES, CARBON	560 OHM 1/5W J	1
....5	R841	CRD20TJ561T	RES, CARBON	560 OHM 1/5W J	1
....5	R842	CRD20TJ561T	RES, CARBON	560 OHM 1/5W J	1
....5	R843	CRD20TJ561T	RES, CARBON	560 OHM 1/5W J	1
....5	R844	CRD20TJ561T	RES, CARBON	560 OHM 1/5W J	1
....5	R845	CRD20TJ561T	RES, CARBON	560 OHM 1/5W J	1
....5	R848	CRD20TJ273T	RES, CARBON	27K OHM 1/5W J	1
....5	R849	CRD20TJ273T	RES, CARBON	27K OHM 1/5W J	1
....5	R850	CRD20TJ182T	RES, CARBON	1.8K OHM 1/5W J	1
....5	R851	CRD20TJ182T	RES, CARBON	1.8K OHM 1/5W J	1
....5	R852	CRD20TJ152T	RES, CARBON	1.5K OHM 1/5W J	1
....5	R853	CRD20TJ152T	RES, CARBON	1.5K OHM 1/5W J	1
....5	R854	CRD20TJ152T	RES, CARBON	1.5K OHM 1/5W J	1
....5	R855	CRD20TJ152T	RES, CARBON	1.5K OHM 1/5W J	1
....5	R856	CRD20TJ221T	RES, CARBON	220 OHM 1/5W J	1
....5	R857	CRD20TJ221T	RES, CARBON	220 OHM 1/5W J	1
....5	R858	CRD20TJ221T	RES, CARBON	220 OHM 1/5W J	1
....5	R859	CRD20TJ221T	RES, CARBON	220 OHM 1/5W J	1
....5	R860	CRD20TJ271T	RES, CARBON	270 OHM 1/5W J	1
....5	R861	CRD20TJ271T	RES, CARBON	270 OHM 1/5W J	1
....5	R862	CRD20TJ333T	RES, CARBON	33K OHM 1/5W J	1
....5	R863	CRD20TJ333T	RES, CARBON	33K OHM 1/5W J	1
....5	R870	CRD20TJ433T	RES, CARBON	43K OHM 1/5W J	1
....5	R871	CRD20TJ433T	RES, CARBON	43K OHM 1/5W J	1
....5	R872	CRD20TJ471T	RES, CARBON	470 OHM 1/5W J	1
....5	R873	CRD20TJ471T	RES, CARBON	470 OHM 1/5W J	1
....5	R874	CRD20TJ331T	RES, CARBON	330 OHM 1/5W J	1
....5	R875	CRD20TJ331T	RES, CARBON	330 OHM 1/5W J	1
....5	R876	CRD20TJ331T	RES, CARBON	330 OHM 1/5W J	1
....5	R877	CRD20TJ331T	RES, CARBON	330 OHM 1/5W J	1
....5	R878	CRD20TJ331T	RES, CARBON	330 OHM 1/5W J	1
....5	R879	CRD20TJ331T	RES, CARBON	330 OHM 1/5W J	1
....5	R880	CRD20TJ331T	RES, CARBON	330 OHM 1/5W J	1
....5	R882	CRD20TJ122T	RES, CARBON	1.2K OHM 1/5W J	1
....5	R883	CRD20TJ122T	RES, CARBON	1.2K OHM 1/5W J	1
....5	R884	CRD20TJ122T	RES, CARBON	1.2K OHM 1/5W J	1
....5	R885	CRD20TJ122T	RES, CARBON	1.2K OHM 1/5W J	1
....5	R886	CRD20TJ122T	RES, CARBON	1.2K OHM 1/5W J	1
....5	R887	CRD20TJ122T	RES, CARBON	1.2K OHM 1/5W J	1
....5	R888	CRD20TJ122T	RES, CARBON	1.2K OHM 1/5W J	1
....5	R891	CRD20TJ391T	RES, CARBON (390 OHM)		1

MAIN PCB ASSY					
Level	Ref. #	Part Number	Description	Drawing No (Value)	Qty
....5	R892	CRD20TJ391T	RES , CARBON (390 OHM)		1
....5	R893	CRD20TJ391T	RES , CARBON (390 OHM)		1
....5	R894	CRD20TJ391T	RES , CARBON (390 OHM)		1
....5	R895	CRD20TJ391T	RES , CARBON (390 OHM)		1
....5	R896	CRD20TJ391T	RES , CARBON (390 OHM)		1
....5	R897	CRD20TJ391T	RES , CARBON (390 OHM)		1
....5	R900	CRD20TJ103T	RES , CARBON	10K OHM 1/5W J	1
....5	R906	CRD20TJ104T	RES , CARBON	100K OHM 1/5W J	1
....5	R912	CRD20TJ332T	RES , CARBON	3.3K OHM 1/5W J	1
....5	R917	CRD25TJ393T	RES , CARBON (39K OHM)		1
....5	R918	CRD25TJ393T	RES , CARBON (39K OHM)		1
....5	R919	CRD25TJ393T	RES , CARBON (39K OHM)		1
....5	R920	CRD25TJ393T	RES , CARBON (39K OHM)		1
....5	R924	CRD20TJ473T	RES , CARBON	47K OHM 1/5W J	1
....5	R925	CRD20TJ473T	RES , CARBON	47K OHM 1/5W J	1
....5	R926	CRD20TJ473T	RES , CARBON	47K OHM 1/5W J	1
....5	R927	CRD20TJ473T	RES , CARBON	47K OHM 1/5W J	1
....5	R928	CRD20TJ222T	RES , CARBON	2.2K OHM 1/5W J	1
....5	R929	CRD20TJ222T	RES , CARBON	2.2K OHM 1/5W J	1
....5	R930	CRD20TJ222T	RES , CARBON	2.2K OHM 1/5W J	1
....5	R931	CRD20TJ222T	RES , CARBON	2.2K OHM 1/5W J	1
....5	R933	CRD20TJ472T	RES , CARBON	4.7K OHM 1/5W J	1
....5	R934	CRD20TJ223T	RES , CARBON	22K OHM 1/5W J	1
....5	R935	CRD20TJ154T	RES , CARBON (150K OHM)		1
....5	R936	CRD20TJ334T	RES , CARBON (330K OHM)		1
....5	R939	CRD20TJ472T	RES , CARBON	4.7K OHM 1/5W J	1
....5	R940	CRD20TJ152T	RES , CARBON	1.5K OHM 1/5W J	1
....5	R941	CRD25TJ223T	RES , CARBON	22K OHM 1/4W J	1
....5	R942	CRD20TJ223T	RES , CARBON	22K OHM 1/5W J	1
....5	R943	CRD20TJ223T	RES , CARBON	22K OHM 1/5W J	1
....5	R944	CRD25TJ223T	RES , CARBON	22K OHM 1/4W J	1
....5	R945	CRD25TJ223T	RES , CARBON	22K OHM 1/4W J	1
....5	R946	CRD20TJ223T	RES , CARBON	22K OHM 1/5W J	1
....5	R947	CRD20TJ223T	RES , CARBON	22K OHM 1/5W J	1
....5	R948	CRD25TJ392T	RES , CARBON	3.9K 1/4W J	1
....5	R949	CRD20TJ334T	RES , CARBON (330K OHM)		1
....5	R952	CRD25TJ223T	RES , CARBON	22K OHM 1/4W J	1
....5	R953	CRD20TJ223T	RES , CARBON	22K OHM 1/5W J	1
....5	R954	CRD20TJ223T	RES , CARBON	22K OHM 1/5W J	1
....5	R955	CRD20TJ223T	RES , CARBON	22K OHM 1/5W J	1
....5	R956	CRD20TJ224T	RES , CARBON	220 KOHM 1/5W J	1
....5	R957	CRD20TJ153T	RES , CARBON	15K OHM 1/5W J	1
....5	R958	CRD20TJ563T	RES , CARBON	56K OHM 1/5W J	1
....5	R959	CRD20TJ104T	RES , CARBON	100K OHM 1/5W J	1
....5	R961	CRD20TJ331T	RES , CARBON	330 OHM 1/5W J	1
....5	R962	CRD20TJ273T	RES , CARBON	27K OHM 1/5W J	1
....5	R964	CRD20TJ223T	RES , CARBON	22K OHM 1/5W J	1
....5	R965	CRD20TJ223T	RES , CARBON	22K OHM 1/5W J	1
....5	R986	CRD20TJ102T	RES , CARBON	1K OHM 1/5W J	1
....5	R987	CRD20TJ561T	RES , CARBON	560 OHM 1/5W J	1
....5	R988	CRD20TJ562T	RES , CARBON	5.6K OHM 1/5W J	1
....5	R989	CRD20TJ302T	RES , CARBON (3K OHM)		1
....5	R991	CRD20TJ822T	RES , CARBON	8.2K OHM 1/5W J	1
....5	R992	KRG1SANJ271RT	RES , METAL OXIDE FILM (270 OHM)		1
....5	R998	CRD20TJ103T	RES , CARBON	10K OHM 1/5W J	1
....5	VR81	CVN1RA221B02T	RES , SEMI FIXED (220, B CURVE)	KVSF637AVC	1
....5	VR82	CVN1RA221B02T	RES , SEMI FIXED (220, B CURVE)	KVSF637AVC	1
....5	VR83	CVN1RA221B02T	RES , SEMI FIXED (220, B CURVE)	KVSF637AVC	1
....5	VR84	CVN1RA221B02T	RES , SEMI FIXED (220, B CURVE)	KVSF637AVC	1
....5	VR85	CVN1RA221B02T	RES , SEMI FIXED (220, B CURVE)	KVSF637AVC	1
....5	VR86	CVN1RA221B02T	RES , SEMI FIXED (220, B CURVE)	KVSF637AVC	1
....5	VR87	CVN1RA221B02T	RES , SEMI FIXED (220, B CURVE)	KVSF637AVC	1
....4		CMYAVR1600/120	HEAT SINK ASS'Y		1
....5		CFNCF12825HSN	FAN , MOTOR		1
....5		CHD1A012R	SCREW , SPECIAL		14
....5		CHD1A036R	SCREW , SPECIAL		4
....5		CHD3A012R	SCREW , SPECIAL		11
....5		CMD1A398	BRACKET , PCB	AG-D9320	2
....5		CMD1A417	BRACKET , PCB	AG-D8900	2
....5		CMD1A694	BRACKET , FAN		1
....5		CMY1A313	HEAT SINK		1
....5		CTB3+8JR	SCREW		8
....5		K8AYG6260	COMPOUND , SILICONE		10
....5	Q652	CVT2SB1559P43M	TR , 2SB1559 (PNP,MT-100,POWER, MICA 43 TYPE)		1
....5	Q653	CVT2SB1559P43M	TR , 2SB1559 (PNP,MT-100,POWER, MICA 43 TYPE)		1
....5	Q654	CVT2SB1559P43M	TR , 2SB1559 (PNP,MT-100,POWER, MICA 43 TYPE)		1
....5	Q655	CVT2SB1559P43M	TR , 2SB1559 (PNP,MT-100,POWER, MICA 43 TYPE)		1
....5	Q657	CVT2SD2389P43M	TR , 2SD2389 (NPN,MT-100,POWER, MICA 43 TYPE)		1
....5	Q658	CVT2SD2389P43M	TR , 2SD2389 (NPN,MT-100,POWER, MICA 43 TYPE)		1



MAIN PCB ASSY					
Level	Ref. #	Part Number	Description	Drawing No (Value)	Qty
...5	Q659	CVT2SD2389P43M	TR , 2SD2389 (NPN,MT-100,POWER, MICA 43 TYPE)		1
...5	Q660	CVT2SD2389P43M	TR , 2SD2389 (NPN,MT-100,POWER, MICA 43 TYPE)		1
...5	Q661	CVT2SB1559P43M	TR , 2SB1559 (PNP,MT-100,POWER, MICA 43 TYPE)		1
...5	Q670	CVT2SD2389P43M	TR , 2SD2389 (NPN,MT-100,POWER, MICA 43 TYPE)		1
...5	Q803	CVT2SD2389P43M	TR , 2SD2389 (NPN,MT-100,POWER, MICA 43 TYPE)		1
...5	Q804	CVT2SB1559P43M	TR , 2SB1559 (PNP,MT-100,POWER, MICA 43 TYPE)		1
...5	Q805	CVT2SD2389P43M	TR , 2SD2389 (NPN,MT-100,POWER, MICA 43 TYPE)		1
...5	Q807	CVT2SB1559P43M	TR , 2SB1559 (PNP,MT-100,POWER, MICA 43 TYPE)		1
...5	Q851	HVTKTD600KGR	T.R , BIAS	KTD600KGR	1
...5	Q852	HVTKTD600KGR	T.R , BIAS	KTD600KGR	1
...5	Q853	HVTKTD600KGR	T.R , BIAS	KTD600KGR	1
...5	Q854	HVTKTD600KGR	T.R , BIAS	KTD600KGR	1
...5	Q855	HVTKTD600KGR	T.R , BIAS	KTD600KGR	1
...5	Q856	HVTKTD600KGR	T.R , BIAS	KTD600KGR	1
...5	Q857	HVTKTD600KGR	T.R , BIAS	KTD600KGR	1
...4	BN14	CWB1D00718088	WIRE ASS'Y (2.5MM, 180MM, 7PIN, DUAL-DIPPING TYPE)		1
...4	BN15	CWB1D00915088	WIRE ASS'Y (2.5mm, 150mm, 9pin, Dual-dipping type)		1
...4	BN20	CWB3F905300UZ	WIRE ASS'Y (3.96mm, 300mm, 5pin)		1
...4	BN25	CWE8112120VV	WIRE ASS'Y (1PIN,120mm,LUG,#18,RED)		1
...4	BN26	CWE8112120VV	WIRE ASS'Y (1PIN,120mm,LUG,#18,RED)		1
...4	CN10	CJP03GA01ZY	WAFER		1
...4	CN11	CJP08GA221ZB	FEMALE HEADER (08P,2.54mm) , STRAIGHT TYPE		1
...4	CN12	CJP27GA41ZM	WAFER (1.25MM, CARD CABLE, STRAIGHT 27)	MOLEX 52045-**45	1
...4	CN61	CJP02GA01ZY	WAFER , STRAIGHT, 2PIN		1
...4	CN62	CJP02GA01ZY	WAFER , STRAIGHT, 2PIN		1
...4	CN63	CJP02GA01ZY	WAFER , STRAIGHT, 2PIN		1
...4	CN64	CJP02GA01ZY	WAFER , STRAIGHT, 2PIN		1
...4	CN65	CJP02GA01ZY	WAFER , STRAIGHT, 2PIN		1
...4	CN66	CJP02GA01ZY	WAFER , STRAIGHT, 2PIN		1
...4	CN67	CJP02GA01ZY	WAFER , STRAIGHT, 2PIN		1
...4	CN89	CJP02GA01ZY	WAFER , STRAIGHT, 2PIN		1
...4	CN90	CJP02GA89ZY	WAFER		1
...4	CN91	CJP02GA89ZY	WAFER		1
...4	CN92	CJP02KA060ZY	WAFER		1
...4	C631	CCEA1JH101E	CAP , ELECT	100UF 63V	1
...4	C632	CCEA1JH101E	CAP , ELECT	100UF 63V	1
...4	C633	CCEA1JH101E	CAP , ELECT	100UF 63V	1
...4	C634	CCEA1JH101E	CAP , ELECT	100UF 63V	1
...4	C635	CCEA1JH101E	CAP , ELECT	100UF 63V	1
...4	C636	CCEA1JH101E	CAP , ELECT	100UF 63V	1
...4	C637	CCEA1JH101E	CAP , ELECT	100UF 63V	1
...4	C638	CCEA1JH101E	CAP , ELECT	100UF 63V	1
...4	C639	CCEA1JH101E	CAP , ELECT	100UF 63V	1
...4	C640	CCEA1JH101E	CAP , ELECT	100UF 63V	1
...4	C807	CCEA1JH101E	CAP , ELECT	100UF 63V	1
...4	C808	CCEA1JH101E	CAP , ELECT	100UF 63V	1
...4	C809	CCEA1JH101E	CAP , ELECT	100UF 63V	1
...4	C810	CCEA1JH101E	CAP , ELECT	100UF 63V	1
...4	C904	KCKDKS472ME	CAP , CERAMIC(X1/Y2/SC)	0.0047UF/2.5KV	1
...4	C906	CCEA1EH102E	CAP , ELECT	1000UF 25V	1
...4	C915	CCET50VKL5153NK	CAP , ELECT(15000uF/50V,30x50,KL5)	KL5-050V153MO500	1
...4	C916	CCET50VKL5153NK	CAP , ELECT(15000uF/50V,30x50,KL5)	KL5-050V153MO500	1
...4	ET92	CMD1A387	BRACKET , PCB		1
...4	ET93	CMD1A387	BRACKET , PCB		1
...4	IC95	HVIKIA78R05PI	REGULATOR (5V OUTPUT LOW DROP)	KIA78R05PI	1
...4	JK90	CJJ4M040Z	JACK , BOARD (SW)		1
...4	JK91	CJJ5R006Z	TERMINAL , SPEAKER		1
...4	JK92	CJJ5Q012Z	TERMINAL , SPEAKER		1
...4	JW91	CWE8112120VV	WIRE ASS'Y (1PIN,120mm,LUG,#18,RED)		1
...4	L501	CLEY0R5KAK	COIL , SPEAKER	0.5UH K	1
...4	L502	CLEY0R5KAK	COIL , SPEAKER	0.5UH K	1
...4	L503	CLEY0R5KAK	COIL , SPEAKER	0.5UH K	1
...4	L504	CLEY0R5KAK	COIL , SPEAKER	0.5UH K	1
...4	L505	CLEY0R5KAK	COIL , SPEAKER	0.5UH K	1
...4	L506	CLEY0R5KAK	COIL , SPEAKER	0.5UH K	1
...4	L507	CLEY0R5KAK	COIL , SPEAKER	0.5UH K	1
...4	Q858	HVTKTA1360Y	T.R , PRE DRIVE	KTA1360Y	1
...4	Q871	HVTKTA1360Y	T.R , PRE DRIVE	KTA1360Y	1
...4	Q872	HVTKTA1360Y	T.R , PRE DRIVE	KTA1360Y	1
...4	Q874	HVTKTA1360Y	T.R , PRE DRIVE	KTA1360Y	1
...4	Q875	HVTKTA1360Y	T.R , PRE DRIVE	KTA1360Y	1
...4	Q876	HVTKTA1360Y	T.R , PRE DRIVE	KTA1360Y	1
...4	Q877	HVTKTA1360Y	T.R , PRE DRIVE	KTA1360Y	1
...4	Q881	HVTKTC3423Y	T.R , PRE DRIVE	KTC3423Y	1
...4	Q882	HVTKTC3423Y	T.R , PRE DRIVE	KTC3423Y	1
...4	Q883	HVTKTC3423Y	T.R , PRE DRIVE	KTC3423Y	1
...4	Q884	HVTKTC3423Y	T.R , PRE DRIVE	KTC3423Y	1
...4	Q885	HVTKTC3423Y	T.R , PRE DRIVE	KTC3423Y	1
...4	Q886	HVTKTC3423Y	T.R , PRE DRIVE	KTC3423Y	1

MAIN PCB ASSY					
Level	Ref. #	Part Number	Description	Drawing No (Value)	Qty
...4	Q887	HVTKTC3423Y	T.R , PRE DRIVE	KTC3423Y	1
...4	RY94	CSL1E002ZE	RELAY , POWER	G5PA-1 (DC 6V)	1
...4	R656	CRF5EKR27HX2K	RES , CEMENT (0.27 OHM)		1
...4	R657	CRF5EKR27HX2K	RES , CEMENT (0.27 OHM)		1
...4	R658	CRF5EKR27HX2K	RES , CEMENT (0.27 OHM)		1
...4	R659	CRF5EKR27HX2K	RES , CEMENT (0.27 OHM)		1
...4	R660	CRF5EKR27HX2K	RES , CEMENT (0.27 OHM)		1
...4	R810	CRF5EKR27HX2K	RES , CEMENT (0.27 OHM)		1
...4	R811	CRF5EKR27HX2K	RES , CEMENT (0.27 OHM)		1
...4	R905	CRG1ANJ1R0H	RES , METAL OXIDE FILM	1 OHM 1W J	1
...4	R922	CRG2ANJ470H	RES , METAL OXIDE FILM	47 OHM 2W J	1
...4	R923	CRG1ANJ220H	RES , METAL OXIDE FILM	22 OHM 1W J	1
...4	R990	CRG1ANJ100H	RES , METAL OXIDE FILM	10 OHM 1W J	1
...4	R993	CRG1ANJ100H	RES , METAL OXIDE FILM	10 OHM 1W J	1
...4	R994	CRG1ANJ100H	RES , METAL OXIDE FILM	10 OHM 1W J	1
...4	R995	CRG1ANJ100H	RES , METAL OXIDE FILM	10 OHM 1W J	1
...4	R996	CRG1ANJ100H	RES , METAL OXIDE FILM	10 OHM 1W J	1
...4	R997	CRG1ANJ100H	RES , METAL OXIDE FILM	10 OHM 1W J	1
...4	R999	CRG1ANJ100H	RES , METAL OXIDE FILM	10 OHM 1W J	1
...4	TH91	KRTP42T7D330B	THERMAL SENSOR , POSISTOR	P42T7D330BW20	1
...4	T902	CLT5I019ZW	TRANS , SUB(AC 240V)		1
POWER PCB ASSY					
Level	Ref. #	Part Number	Description	Drawing No (Value)	Qty
..3		<b>COP12172E</b>	<b>AVR160 POWER PCB ASS'Y</b>		<b>1</b>
...5	C104	HCQI1H103JZT	CAP , MYLAR	0.01UF 50V J	1
...5	C105	HCQI1H103JZT	CAP , MYLAR	0.01UF 50V J	1
...5	C106	HCQI1H104JZT	CAP , MYLAR	0.1UF 50V J	1
...5	C107	HCQI1H103JZT	CAP , MYLAR	0.01UF 50V J	1
...5	C108	HCQI1H103JZT	CAP , MYLAR	0.01UF 50V J	1
...5	C109	HCQI1H104JZT	CAP , MYLAR	0.1UF 50V J	1
...5	C110	CCEA1CH101T	CAP , ELECT	100UF 16V	1
...5	C123	CCFT1H473ZF	CAP , CERAMIC	0.047UF 50V Z	1
...5	C124	CCFT1H473ZF	CAP , CERAMIC	0.047UF 50V Z	1
...5	C125	CCBS1H473ZFT	CAP , CERAMIC(47000PF/50V)	CH UP025 F473Z-A-B J	1
...5	C127	CCBS1H104ZFT	CAP , CERAMIC	0.1UF 50V Z	1
...5	C131	CCEA1HH4R7T	CAP , ELECT	4.7UF 50V	1
...5	C132	CCFT1H473ZF	CAP , CERAMIC	0.047UF 50V Z	1
...5	C133	CCFT1H473ZF	CAP , CERAMIC	0.047UF 50V Z	1
...5	C134	CCFT1H473ZF	CAP , CERAMIC	0.047UF 50V Z	1
...5	C135	CCBS1H104ZFT	CAP , CERAMIC	0.1UF 50V Z	1
...5	C136	CCBS1H104ZFT	CAP , CERAMIC	0.1UF 50V Z	1
...5	C750	CCEA1CH101T	CAP , ELECT	100UF 16V	1
...5	C752	CCEA1CH101T	CAP , ELECT	100UF 16V	1
...5	C911	CCEA1HKS2R2T	CAP , ELECT	2.2UF 50V SMALL SIZE	1
...5	C912	CCEA0JH102T	CAP , ELECT	1000UF 6.3V	1
...5	C919	CKT1H102KB	CAP , CERAMIC	1000PF 50V K	1
...5	C920	CCEA1HH470T	CAP , ELECT	47UF 50V	1
...5	C922	KCME2E104JP04T	CAP , METALLIZED FILM (0.1UF/250V)		1
...5	C925	CCME2A103JXT	CAP , METALLIZED FILM (0.01UF/100V)		1
...5	C926	CCME2A103JXT	CAP , METALLIZED FILM (0.01UF/100V)		1
...5	C931	HCQI1H473JZT	CAP , MYLAR	0.047UF 50V J	1
...5	C932	HCQI1H473JZT	CAP , MYLAR	0.047UF 50V J	1
...5	C935	CCBS1H104ZFT	CAP , CERAMIC	0.1UF 50V Z	1
...5	C936	CCBS1H473ZFT	CAP , CERAMIC(47000PF/50V)	CH UP025 F473Z-A-B J	1
...5	C937	CCBS1H104ZFT	CAP , CERAMIC	0.1UF 50V Z	1
...5	C938	CCEA1CH101T	CAP , ELECT	100UF 16V	1
...5	C939	CCEA1EH101T	CAP , ELECT	100UF 25V	1
...5	C940	CCEA1EH101T	CAP , ELECT	100UF 25V	1
...5	D114	CVD1N4003ST	DIODE , RECT	1N4003	1
...5	D115	CVD1N4003ST	DIODE , RECT	1N4003	1
...5	D116	CVD1N4003ST	DIODE , RECT	1N4003	1
...5	D117	CVD1N4003ST	DIODE , RECT	1N4003	1
...5	D124	CVD1N4003ST	DIODE , RECT	1N4003	1
...5	D125	CVD1N4003ST	DIODE , RECT	1N4003	1
...5	D801	CVD1SS133MT	DIODE	1SS133	1
...5	D802	CVD1SS133MT	DIODE	1SS133	1
...5	F110	KBA2D3150A2EYT	FUSE(382 Series, 250V, 3.15A)	382 250V/3.15	1
...5	F111	KBA2D3150A2EYT	FUSE(382 Series, 250V, 3.15A)	382 250V/3.15	1
...5	Q911	HVTKTA1267YT	T.R	KTA1267Y	1
...5	Q912	HVTKTC3198YT	T.R	KTC3198Y	1
...5	Q913	HVTKTC3198YT	T.R	KTC3198Y	1
...5	R120	CRD20TJ103T	RES , CARBON	10K OHM 1/5W J	1
...5	R750	CRD20TJ103T	RES , CARBON	10K OHM 1/5W J	1
...5	R751	CRD20TJ103T	RES , CARBON	10K OHM 1/5W J	1
...5	R901	CRD20TJ272T	RES , CARBON	2.7K OHM 1/5W J	1
...5	R912	CRD20TJ153T	RES , CARBON	15K OHM 1/5W J	1
...5	R913	CRD20TJ153T	RES , CARBON	15K OHM 1/5W J	1





VIDEO PCB ASSY					
Level	Ref. #	Part Number	Description	Drawing No (Value)	Qty
...5	C672	CCBS1H104ZFT	CAP , CERAMIC	0.1UF 50V Z	1
...5	C673	CCEA1HH100T	CAP , ELECT	10UF 50V	1
...5	C701	CCBS1H270JT	CAP , CERAMIC(27PF/50V)	CH UP025SL270J-A-B Z	1
...5	C702	CCBS1H270JT	CAP , CERAMIC(27PF/50V)	CH UP025SL270J-A-B Z	1
...5	C703	CCBS1H270JT	CAP , CERAMIC(27PF/50V)	CH UP025SL270J-A-B Z	1
...5	C704	CCBS1H270JT	CAP , CERAMIC(27PF/50V)	CH UP025SL270J-A-B Z	1
...5	C705	CCBS1H181KBT	CAP , CERAMIC(180PF/50V)	CH UP025 B181K-A-B Z	1
...5	C708	CCEA1HHR47T	CAP , ELECT	0.47UF 50V	1
...5	C711	CCEA1AH471T	CAP , ELECT	470UF 10V	1
...5	C712	CCEA1HH100T	CAP , ELECT	10UF 50V	1
...5	C717	CCBS1H220JCT	CAP , CERAMIC(22PF/50V)	CH UP025CH220J-A-B Z	1
...5	C721	CCBS1H560JT	CAP , CERAMIC(56PF/50V)	CH UP025SL560J-A-B Z	1
...5	C722	CCBS1H220JCT	CAP , CERAMIC(22PF/50V)	CH UP025CH220J-A-B Z	1
...5	C723	CCEA1HH0R1T	CAP , ELECT	0.1UF 50V	1
...5	C725	HCQI1H682JZT	CAP , MYLAR	6800PF 50V J	1
...5	C726	CCEA1HH1R0T	CAP , ELECT	1UF 50V	1
...5	C731	CCBS1H220JCT	CAP , CERAMIC(22PF/50V)	CH UP025CH220J-A-B Z	1
...5	C732	CCBS1H330JT	CAP , CERAMIC(33PF/50V)	CH UP025SL330J-A-B Z	1
...5	C733	CCBS1H223ZFT	CAP , CERAMIC(22000PF/50V)	CH UP025 F223Z-A-B J	1
...5	C734	CCEA1HH1R0T	CAP , ELECT	1UF 50V	1
...5	C736	CCBS1H223ZFT	CAP , CERAMIC(22000PF/50V)	CH UP025 F223Z-A-B J	1
...5	C737	CCEA1CH101T	CAP , ELECT	100UF 16V	1
...5	C741	CCBS1H223ZFT	CAP , CERAMIC(22000PF/50V)	CH UP025 F223Z-A-B J	1
...5	L731	KLQ5R6J405T	COIL , PEAKING(RADIAL)	5.6UH J 4X5	1
...5	L736	HLQ02C101JT	COIL , AXAIL	100UH ,J	1
...5	Q512	HVTKRC107MT	T.R	KRC107M	1
...5	Q712	HVTKTA1267YT	T.R	KTA1267Y	1
...5	Q716	HVTKTC3199YT	T.R	KTC3199Y	1
...5	R401	CRD20TJ470T	RES , CARBON	47 OHM 1/5W J	1
...5	R402	C3A206	WIRE , COPPER	SN95/PB5 , 0.6	0,018
...5	R411	CRD20TJ750T	RES , CARBON	75 OHM 1/5W J	1
...5	R421	CRD20TJ750T	RES , CARBON	75 OHM 1/5W J	1
...5	R451	CRD20TJ750T	RES , CARBON	75 OHM 1/5W J	1
...5	R461	CRD20TJ102T	RES , CARBON	1K OHM 1/5W J	1
...5	R491	CRD20TJ750T	RES , CARBON	75 OHM 1/5W J	1
...5	R601	CRD20TJ560T	RES , CARBON	56 OHM 1/5W J	1
...5	R603	CRD20TJ360T	RES , CARBON (36 OHM)		1
...5	R605	CRD20TJ470T	RES , CARBON	47 OHM 1/5W J	1
...5	R611	CRD20TJ750T	RES , CARBON	75 OHM 1/5W J	1
...5	R613	CRD20TJ750T	RES , CARBON	75 OHM 1/5W J	1
...5	R615	CRD20TJ750T	RES , CARBON	75 OHM 1/5W J	1
...5	R621	CRD20TJ750T	RES , CARBON	75 OHM 1/5W J	1
...5	R623	CRD20TJ750T	RES , CARBON	75 OHM 1/5W J	1
...5	R625	CRD20TJ750T	RES , CARBON	75 OHM 1/5W J	1
...5	R674	CRD20TJ330T	RES , CARBON	33 OHM 1/5W J	1
...5	R675	CRD20TJ330T	RES , CARBON	33 OHM 1/5W J	1
...5	R676	CRD20TJ470T	RES , CARBON	47 OHM 1/5W J	1
...5	R677	CRD20TJ360T	RES , CARBON (36 OHM)		1
...5	R678	CRD20TJ560T	RES , CARBON	56 OHM 1/5W J	1
...5	R701	CRD20TJ222T	RES , CARBON	2.2K OHM 1/5W J	1
...5	R705	CRD20TJ102T	RES , CARBON	1K OHM 1/5W J	1
...5	R706	CRD20TJ102T	RES , CARBON	1K OHM 1/5W J	1
...5	R707	CRD20TJ102T	RES , CARBON	1K OHM 1/5W J	1
...5	R711	CRD20TJ104T	RES , CARBON	100K OHM 1/5W J	1
...5	R713	CRD20TJ222T	RES , CARBON	2.2K OHM 1/5W J	1
...5	R714	CRD20TJ122T	RES , CARBON	1.2K OHM 1/5W J	1
...5	R715	CRD20TJ822T	RES , CARBON	8.2K OHM 1/5W J	1
...5	R716	CRD20TJ103T	RES , CARBON	10K OHM 1/5W J	1
...5	R717	CRD20TJ271T	RES , CARBON	270 OHM 1/5W J	1
...5	R721	CRD20TJ222T	RES , CARBON	2.2K OHM 1/5W J	1
...5	R724	CRD20TJ393T	RES , CARBON (39K OHM)		1
...5	R725	CRD20TJ152T	RES , CARBON	1.5K OHM 1/5W J	1
...5	R726	CRD20TJ682T	RES , CARBON	6.8K OHM 1/5W J	1
...5	R727	CRD20TJ102T	RES , CARBON	1K OHM 1/5W J	1
...5	R728	CRD20TJ102T	RES , CARBON	1K OHM 1/5W J	1
...5	R735	CRD20TJ102T	RES , CARBON	1K OHM 1/5W J	1
...5	R737	CRD20TJ104T	RES , CARBON	100K OHM 1/5W J	1
...5	R742	CRD20TJ102T	RES , CARBON	1K OHM 1/5W J	1
...5	R743	CRD20TJ102T	RES , CARBON	1K OHM 1/5W J	1
...5	R744	CRD20TJ102T	RES , CARBON	1K OHM 1/5W J	1
...4	BN14	CJP15GA115ZY	WAFER , CARD CABLE		1
...4	CN18	CJP18GB142ZB	PIN HEADER (18P , 2.54mm) , ANGLE TYPE		1
...4	JK61	CJJ4S010Z	JACK , BOARD		1
...4	JK62	CJJ4R045Z	JACK , BOARD		1
...4	JK63	CJJ4N043Z	JACK , BOARD		1
...4	JK64	CJJ4S030Z	JACK , BOARD	3P,G/B/R,SILVER	1
...4	X701	HOX17734E220C	CRYSTAL (17.734MHz)		1
...4	X703	HOX14318E220C	CRYSTAL (14.318MHz)		1

INPUT PCB ASSY					
Level	Ref. #	Part Number	Description	Drawing No (Value)	Qty
..3		<b>COP12176E</b>	<b>AVR160 INPUT PCB ASSY</b>		<b>1</b>
....6	CN15	CJP17GA193ZY	WAFER, CARD CABLE (SMD)		1
....6	C200	CCUS1H104KC	CAP, CHIP	0.1UF 50V K	1
....6	C201	CCUS1H471JA	CAP, CHIP	470PF 50V J	1
....6	C202	CCUS1H471JA	CAP, CHIP	470PF 50V J	1
....6	C203	CCUS1H471JA	CAP, CHIP	470PF 50V J	1
....6	C204	CCUS1H471JA	CAP, CHIP	470PF 50V J	1
....6	C205	CCUS1H471JA	CAP, CHIP	470PF 50V J	1
....6	C206	CCUS1H471JA	CAP, CHIP	470PF 50V J	1
....6	C207	CCUS1H471JA	CAP, CHIP	470PF 50V J	1
....6	C208	CCUS1H471JA	CAP, CHIP	470PF 50V J	1
....6	C209	CCUS1H471JA	CAP, CHIP	470PF 50V J	1
....6	C210	CCUS1H471JA	CAP, CHIP	470PF 50V J	1
....6	C211	CCUS1H471JA	CAP, CHIP	470PF 50V J	1
....6	C212	CCUS1H471JA	CAP, CHIP	470PF 50V J	1
....6	C213	CCUS1H471JA	CAP, CHIP	470PF 50V J	1
....6	C214	CCUS1H471JA	CAP, CHIP	470PF 50V J	1
....6	C215	CCUS1H471JA	CAP, CHIP	470PF 50V J	1
....6	C216	CCUS1H471JA	CAP, CHIP	470PF 50V J	1
....6	C219	CCUS1H471JA	CAP, CHIP	470PF 50V J	1
....6	C220	CCUS1H471JA	CAP, CHIP	470PF 50V J	1
....6	C221	CCUS1H471JA	CAP, CHIP	470PF 50V J	1
....6	C222	CCUS1H471JA	CAP, CHIP	470PF 50V J	1
....6	C223	CCUS1H471JA	CAP, CHIP	470PF 50V J	1
....6	C224	CCUS1H221JA	CAP, CHIP	220PF 50V J	1
....6	C225	CCUS1H471JA	CAP, CHIP	470PF 50V J	1
....6	C226	CCUS1H471JA	CAP, CHIP	470PF 50V J	1
....6	C254	CCUS1H104KC	CAP, CHIP	0.1UF 50V K	1
....6	C255	CCUS1H150JA	CAP, CHIP(15PF/50V)	15PF 50V J	1
....6	C256	CCUS1H150JA	CAP, CHIP(15PF/50V)	15PF 50V J	1
....6	C257	CCUS1H200JA	CAP, CHIP (20PF)		1
....6	C258	CCUS1H220JA	CAP, CHIP	22PF 50V J	1
....6	C259	CCUS1H104KC	CAP, CHIP	0.1UF 50V K	1
....6	C260	CCUS1H104KC	CAP, CHIP	0.1UF 50V K	1
....6	C269	CCUS1A105KC	CAP, CHIP	1UF 10V K	1
....6	C274	CCUS1A105KC	CAP, CHIP	1UF 10V K	1
....6	C277	CCUS1H104KC	CAP, CHIP	0.1UF 50V K	1
....6	C279	CCUS1H104KC	CAP, CHIP	0.1UF 50V K	1
....6	C280	CCUS1H104KC	CAP, CHIP	0.1UF 50V K	1
....6	C289	CCUS1H104KC	CAP, CHIP	0.1UF 50V K	1
....6	C290	CCUS1H104KC	CAP, CHIP	0.1UF 50V K	1
....6	C291	CCUS1H104KC	CAP, CHIP	0.1UF 50V K	1
....6	C293	CCUS1H104KC	CAP, CHIP	0.1UF 50V K	1
....6	C295	CCUS1H272KC	CAP, CHIP	2700PF 50V K	1
....6	C296	CCUS1H272KC	CAP, CHIP	2700PF 50V K	1
....6	C299	CCUS1H104KC	CAP, CHIP	0.1UF 50V K	1
....6	C301	CCUS1H152KC	CAP, CHIP	1500PF 50V K	1
....6	C302	CCUS1H152KC	CAP, CHIP	1500PF 50V K	1
....6	C303	CCUS1H152KC	CAP, CHIP	1500PF 50V K	1
....6	C304	CCUS1H152KC	CAP, CHIP	1500PF 50V K	1
....6	C305	CCUS1H152KC	CAP, CHIP	1500PF 50V K	1
....6	C306	CCUS1H152KC	CAP, CHIP	1500PF 50V K	1
....6	C307	CCUS1H152KC	CAP, CHIP	1500PF 50V K	1
....6	C308	CCUS1H152KC	CAP, CHIP	1500PF 50V K	1
....6	C309	CCUS1H102KC	CAP, CHIP	1000PF 50V K	1
....6	C310	CCUS1H102KC	CAP, CHIP	1000PF 50V K	1
....6	C311	CCUS1H102KC	CAP, CHIP	1000PF 50V K	1
....6	C312	CCUS1H102KC	CAP, CHIP	1000PF 50V K	1
....6	C313	CCUS1H102KC	CAP, CHIP	1000PF 50V K	1
....6	C314	CCUS1H102KC	CAP, CHIP	1000PF 50V K	1
....6	C315	CCUS1H102KC	CAP, CHIP	1000PF 50V K	1
....6	C316	CCUS1H102KC	CAP, CHIP	1000PF 50V K	1
....6	C317	CCUS1H223KC	CAP, CHIP	0.022UF 50V K	1
....6	C318	CCUS1H223KC	CAP, CHIP	0.022UF 50V K	1
....6	C319	CCUS1H223KC	CAP, CHIP	0.022UF 50V K	1
....6	C320	CCUS1H223KC	CAP, CHIP	0.022UF 50V K	1
....6	C321	CCUS1H271JA	CAP, CHIP	270PF 50V J	1
....6	C322	CCUS1H271JA	CAP, CHIP	270PF 50V J	1
....6	C323	CCUS1H271JA	CAP, CHIP	270PF 50V J	1
....6	C324	CCUS1H271JA	CAP, CHIP	270PF 50V J	1
....6	C325	CCUS1H561JA	CAP, CHIP	560PF 50V J	1
....6	C326	CCUS1H561JA	CAP, CHIP	560PF 50V J	1
....6	C327	CCUS1H561JA	CAP, CHIP	560PF 50V J	1
....6	C328	CCUS1H561JA	CAP, CHIP	560PF 50V J	1
....6	C329	CCUS1H561JA	CAP, CHIP	560PF 50V J	1
....6	C330	CCUS1H561JA	CAP, CHIP	560PF 50V J	1
....6	C331	CCUS1H561JA	CAP, CHIP	560PF 50V J	1
....6	C332	CCUS1H561JA	CAP, CHIP	560PF 50V J	1

INPUT PCB ASSY					
Level	Ref. #	Part Number	Description	Drawing No (Value)	Qty
....6	C333	CCUS1H561JA	CAP ,CHIP	560PF 50V J	1
....6	C334	CCUS1H561JA	CAP ,CHIP	560PF 50V J	1
....6	C335	CCUS1H561JA	CAP ,CHIP	560PF 50V J	1
....6	C336	CCUS1H561JA	CAP ,CHIP	560PF 50V J	1
....6	C337	CCUS1H223KC	CAP ,CHIP	0.022UF 50V K	1
....6	C338	CCUS1H223KC	CAP ,CHIP	0.022UF 50V K	1
....6	C339	CCUS1H223KC	CAP ,CHIP	0.022UF 50V K	1
....6	C340	CCUS1H223KC	CAP ,CHIP	0.022UF 50V K	1
....6	C350	CCUS1H102KC	CAP ,CHIP	1000PF 50V K	1
....6	C351	CCUS1H102KC	CAP ,CHIP	1000PF 50V K	1
....6	C352	CCUS1H102KC	CAP ,CHIP	1000PF 50V K	1
....6	C353	CCUS1H102KC	CAP ,CHIP	1000PF 50V K	1
....6	C354	CCUS1H102KC	CAP ,CHIP	1000PF 50V K	1
....6	C355	CCUS1H102KC	CAP ,CHIP	1000PF 50V K	1
....6	C356	CCUS1H102KC	CAP ,CHIP	1000PF 50V K	1
....6	C357	CCUS1H102KC	CAP ,CHIP	1000PF 50V K	1
....6	C362	CCUS1H223KC	CAP ,CHIP	0.022UF 50V K	1
....6	C363	CCUS1H103KC	CAP ,CHIP	0.01UF 50V K	1
....6	C364	CCUS1H392KC	CAP ,CHIP CERAMIC(1608, 3900p)	3900PF 50V K	1
....6	C365	CCUS1H822KC	CAP ,CHIP(8200pF/50V,1608 SIZE)	0603B822K101B	1
....6	C369	CCUS1H223KC	CAP ,CHIP	0.022UF 50V K	1
....6	C370	CCUS1H223KC	CAP ,CHIP	0.022UF 50V K	1
....6	C381	CCUS1H223KC	CAP ,CHIP	0.022UF 50V K	1
....6	C382	CCUS1H223KC	CAP ,CHIP	0.022UF 50V K	1
....6	C383	CCUS1H223KC	CAP ,CHIP	0.022UF 50V K	1
....6	C384	CCUS1H223KC	CAP ,CHIP	0.022UF 50V K	1
....6	C385	CCUS1H223KC	CAP ,CHIP	0.022UF 50V K	1
....6	C386	CCUS1H223KC	CAP ,CHIP	0.022UF 50V K	1
....6	C387	CCUS1H223KC	CAP ,CHIP	0.022UF 50V K	1
....6	C388	CCUS1H223KC	CAP ,CHIP	0.022UF 50V K	1
....6	C391	CCUS1H151JA	CAP ,CHIP	150PF 50V J	1
....6	C392	CCUS1H151JA	CAP ,CHIP	150PF 50V J	1
....6	C393	CCUS1H151JA	CAP ,CHIP	150PF 50V J	1
....6	C394	CCUS1H102KC	CAP ,CHIP	1000PF 50V K	1
....6	C395	CCUS1H151JA	CAP ,CHIP	150PF 50V J	1
....6	C396	CCUS1H151JA	CAP ,CHIP	150PF 50V J	1
....6	C397	CCUS1H151JA	CAP ,CHIP	150PF 50V J	1
....6	C398	CCUS1H151JA	CAP ,CHIP	150PF 50V J	1
....6	C399	CCUS1H104KC	CAP ,CHIP	0.1UF 50V K	1
....6	C407	CCUS1H104KC	CAP ,CHIP	0.1UF 50V K	1
....6	C408	CCUS1H104KC	CAP ,CHIP	0.1UF 50V K	1
....6	C409	CCUS1H104KC	CAP ,CHIP	0.1UF 50V K	1
....6	C410	CCUS1H104KC	CAP ,CHIP	0.1UF 50V K	1
....6	C411	CCUS1H104KC	CAP ,CHIP	0.1UF 50V K	1
....6	C412	CCUS1H392KC	CAP ,CHIP CERAMIC(1608, 3900p)	3900PF 50V K	1
....6	C413	CCUS1H822KC	CAP ,CHIP(8200pF/50V,1608 SIZE)	0603B822K101B	1
....6	C415	CCEA1HH100T	CAP ,ELECT	10UF 50V	1
....6	C532	CCUS1H182KC	CAP ,CHIP(1800PF/50V/1608/X7R)	1800PF 50V K	1
....6	C534	CCUS1H182KC	CAP ,CHIP(1800PF/50V/1608/X7R)	1800PF 50V K	1
....6	C535	CCUS1H182KC	CAP ,CHIP(1800PF/50V/1608/X7R)	1800PF 50V K	1
....6	C536	CCUS1H182KC	CAP ,CHIP(1800PF/50V/1608/X7R)	1800PF 50V K	1
....6	C537	CCUS1H182KC	CAP ,CHIP(1800PF/50V/1608/X7R)	1800PF 50V K	1
....6	C538	CCUS1H182KC	CAP ,CHIP(1800PF/50V/1608/X7R)	1800PF 50V K	1
....6	C539	CCUS1H182KC	CAP ,CHIP(1800PF/50V/1608/X7R)	1800PF 50V K	1
....6	C540	CCUS1H182KC	CAP ,CHIP(1800PF/50V/1608/X7R)	1800PF 50V K	1
....6	C601	CCUS1H104KC	CAP ,CHIP	0.1UF 50V K	1
....6	C603	CCUS1H104KC	CAP ,CHIP	0.1UF 50V K	1
....6	C605	CCUS1H104KC	CAP ,CHIP	0.1UF 50V K	1
....6	C607	CCUS1H104KC	CAP ,CHIP	0.1UF 50V K	1
....6	C609	CCUS1H104KC	CAP ,CHIP	0.1UF 50V K	1
....6	C611	CCUS1H104KC	CAP ,CHIP	0.1UF 50V K	1
....6	C613	CCUS1H104KC	CAP ,CHIP	0.1UF 50V K	1
....6	C615	CCUS1H104KC	CAP ,CHIP	0.1UF 50V K	1
....6	C617	CCUS1H104KC	CAP ,CHIP	0.1UF 50V K	1
....6	C619	CCUS1H104KC	CAP ,CHIP	0.1UF 50V K	1
....6	C621	CCUS1H104KC	CAP ,CHIP	0.1UF 50V K	1
....6	C623	CCUS1H104KC	CAP ,CHIP	0.1UF 50V K	1
....6	C625	CCUS1H104KC	CAP ,CHIP	0.1UF 50V K	1
....6	C627	CCUS1H104KC	CAP ,CHIP	0.1UF 50V K	1
....6	C629	CCUS1H104KC	CAP ,CHIP	0.1UF 50V K	1
....6	C631	CCUS1H104KC	CAP ,CHIP	0.1UF 50V K	1
....6	C701	CCUS1H200JA	CAP ,CHIP (20PF)		1
....6	C702	CCUS1H200JA	CAP ,CHIP (20PF)		1
....6	C704	CCUS1H104KC	CAP ,CHIP	0.1UF 50V K	1
....6	C705	CCUS1H104KC	CAP ,CHIP	0.1UF 50V K	1
....6	C707	CCUS1H102KC	CAP ,CHIP	1000PF 50V K	1
....6	C708	CCUS1H104KC	CAP ,CHIP	0.1UF 50V K	1
....6	C718	CCUS1H104KC	CAP ,CHIP	0.1UF 50V K	1
....6	C719	CCUS1H104KC	CAP ,CHIP	0.1UF 50V K	1

INPUT PCB ASSY					
Level	Ref. #	Part Number	Description	Drawing No (Value)	Qty
....6	C722	CCUS1H104KC	CAP , CHIP	0.1UF 50V K	1
....6	C723	CCUS1H473KC	CAP , CHIP	0.047UF 50V K	1
....6	C725	CCUS1H104KC	CAP , CHIP	0.1UF 50V K	1
....6	C727	CCUS1H104KC	CAP , CHIP	0.1UF 50V K	1
....6	C729	CCUS1H104KC	CAP , CHIP	0.1UF 50V K	1
....6	C731	CCUS1H104KC	CAP , CHIP	0.1UF 50V K	1
....6	C733	CCUS1H104KC	CAP , CHIP	0.1UF 50V K	1
....6	C734	CCUS1H104KC	CAP , CHIP	0.1UF 50V K	1
....6	C738	CCUS1A105KC	CAP , CHIP	1UF 10V K	1
....6	C739	CCUS1H103KC	CAP , CHIP	0.01UF 50V K	1
....6	C741	CCUS1H104KC	CAP , CHIP	0.1UF 50V K	1
....6	C742	CCUS1H330JA	CAP , CHIP	33PF 50V J	1
....6	C743	CCUS1H104KC	CAP , CHIP	0.1UF 50V K	1
....6	C744	CCUS1H330JA	CAP , CHIP	33PF 50V J	1
....6	C745	CCUS1H104KC	CAP , CHIP	0.1UF 50V K	1
....6	C746	CCUS1H104KC	CAP , CHIP	0.1UF 50V K	1
....6	C747	CCUS1H104KC	CAP , CHIP	0.1UF 50V K	1
....6	C748	CCUS1H104KC	CAP , CHIP	0.1UF 50V K	1
....6	C754	CCUS1H104KC	CAP , CHIP	0.1UF 50V K	1
....6	C756	CCUS1H104KC	CAP , CHIP	0.1UF 50V K	1
....6	C758	CCUS1H104KC	CAP , CHIP	0.1UF 50V K	1
....6	C759	CCUS1H104KC	CAP , CHIP	0.1UF 50V K	1
....6	C760	CCUS1H104KC	CAP , CHIP	0.1UF 50V K	1
....6	C761	CCUS1H104KC	CAP , CHIP	0.1UF 50V K	1
....6	C762	CCUS1H104KC	CAP , CHIP	0.1UF 50V K	1
....6	C763	CCUS1H104KC	CAP , CHIP	0.1UF 50V K	1
....6	C765	CCUS1H104KC	CAP , CHIP	0.1UF 50V K	1
....6	C768	CCUS1H104KC	CAP , CHIP	0.1UF 50V K	1
....6	C769	CCUS1H104KC	CAP , CHIP	0.1UF 50V K	1
....6	C770	CCUS1H104KC	CAP , CHIP	0.1UF 50V K	1
....6	C771	CCUS1H104KC	CAP , CHIP	0.1UF 50V K	1
....6	C772	CCUS1H104KC	CAP , CHIP	0.1UF 50V K	1
....6	C773	CCUS1H104KC	CAP , CHIP	0.1UF 50V K	1
....6	C775	CCUS1H104KC	CAP , CHIP	0.1UF 50V K	1
....6	C778	CCUS1A105KC	CAP , CHIP	1UF 10V K	1
....6	C780	CCUS1H102KC	CAP , CHIP	1000PF 50V K	1
....6	C781	CCUS1H223KC	CAP , CHIP	0.022UF 50V K	1
....6	C782	CCUS1H103KC	CAP , CHIP	0.01UF 50V K	1
....6	C783	CCUS1H103KC	CAP , CHIP	0.01UF 50V K	1
....6	C784	CCUS1H103KC	CAP , CHIP	0.01UF 50V K	1
....6	C785	CCUS1H104KC	CAP , CHIP	0.1UF 50V K	1
....6	C787	CCUS1H103KC	CAP , CHIP	0.01UF 50V K	1
....6	C789	CCUS1H103KC	CAP , CHIP	0.01UF 50V K	1
....6	C790	CCUS1H103KC	CAP , CHIP	0.01UF 50V K	1
....6	C791	CCUS1H104KC	CAP , CHIP	0.1UF 50V K	1
....6	C793	CCUS1H101JA	CAP , CHIP	100PF 50V J	1
....6	C794	CCUS1H181JA	CAP , CHIP	180PF 50V J	1
....6	C795	CCUS1H181JA	CAP , CHIP	180PF 50V J	1
....6	C796	CCUS1H104KC	CAP , CHIP	0.1UF 50V K	1
....6	C797	CCUS1H104KC	CAP , CHIP	0.1UF 50V K	1
....6	C798	CCUS1H104KC	CAP , CHIP	0.1UF 50V K	1
....6	C820	CCUS1H104KC	CAP , CHIP	0.1UF 50V K	1
....6	D201	HVD1SS355T	DIODE , CHIP		1
....6	D202	HVD1SS355T	DIODE , CHIP		1
....6	D203	HVD1SS355T	DIODE , CHIP		1
....6	D204	HVD1SS355T	DIODE , CHIP		1
....6	D207	HVD1SS355T	DIODE , CHIP		1
....6	D208	HVD1SS355T	DIODE , CHIP		1
....6	D209	HVD1SS355T	DIODE , CHIP		1
....6	D210	HVD1SS355T	DIODE , CHIP		1
....6	D211	HVD1SS355T	DIODE , CHIP		1
....6	D212	HVD1SS355T	DIODE , CHIP		1
....6	D213	HVD1SS355T	DIODE , CHIP		1
....6	D214	HVD1SS355T	DIODE , CHIP		1
....6	D215	HVD1SS355T	DIODE , CHIP		1
....6	D216	HVD1SS355T	DIODE , CHIP		1
....6	IC20	CVINJW1197CFC2	I.C , VOL WITH INPUT SELECTOR	NJW1197CFC2	1
....6	IC21	HVINJM2068MTE1	I.C , OP AMP (JRC)	NJM2068M-TE1	1
....6	IC22	HVINJM2068MTE1	I.C , OP AMP (JRC)	NJM2068M-TE1	1
....6	IC23	HVINJM2068MTE1	I.C , OP AMP (JRC)	NJM2068M-TE1	1
....6	IC24	HVINJM2068MTE1	I.C , OP AMP (JRC)	NJM2068M-TE1	1
....6	IC25	HVINJM2068MTE1	I.C , OP AMP (JRC)	NJM2068M-TE1	1
....6	IC31	HVINJM2068MTE1	I.C , OP AMP (JRC)	NJM2068M-TE1	1
....6	IC32	HVINJM2068MTE1	I.C , OP AMP (JRC)	NJM2068M-TE1	1
....6	IC33	HVINJM2068MTE1	I.C , OP AMP (JRC)	NJM2068M-TE1	1
....6	IC34	HVINJM2068MTE1	I.C , OP AMP (JRC)	NJM2068M-TE1	1
....6	IC38	HVTKTC812TB	T.R , CHIP(TS6)	KTC812T-B-RTK	1
....6	IC39	HVTKTC812TB	T.R , CHIP(TS6)	KTC812T-B-RTK	1
....6	IC40	HVTKTC812TB	T.R , CHIP(TS6)	KTC812T-B-RTK	1



INPUT PCB ASSY					
Level	Ref. #	Part Number	Description	Drawing No (Value)	Qty
....6	IC41	HVTKTC812TB	T.R , CHIP(TS6)	KTC812T-B-RTK	1
....6	IC42	CVIKIA1117S18	I.C , REGULATOR(SOT-223)	KIA1117S/F18, SOT-223	1
....6	IC43	CVIKIA1117S33	I.C , REGULATOR(SOT-223)	KIA1117S/F33, SOT-223	1
....6	IC44	CVIM12L16161A5TG	I.C, 16MB SDRAM (ESMT)		1
....6	IC45	HVTKTC812TB	T.R , CHIP(TS6)	KTC812T-B-RTK	1
....6	IC46	CVIM24C32WMN6TP	I.C , EEPROM (32 Kbit) ST		1
....6	IC47	CVIF25L008A50PAG	I.C , 8Mbit SPI Serial FLASH (50MHz/8lead SOI	F25L008A-50PAG	1
....6	IC48	CVIANAM1458AT	I.C , U-COM (AVR1600)		1
....7		CVIT5CN5	I.C , U-COM (512KB/32KB, LQFP100P) TOSHIBA		1
....6	IC49	CVITMP92FD28FG	I.C , USB DECODER FLASH(100PIN, QFP) TO	TMP92FD28DFG, FLASH	1
....6	IC50	HVITC74HCU04AFN	IC , INVERTER	TC74HCU04AFN	1
....6	IC51	HVICS42528-CQ	I.C , CODEC + DIR (CIRRUS LOGIC)	CS42528-CQ	1
....6	IC52	HVINJM2391DL133	I.C , CHIP REGULATOR (+3.3V) JRC		1
....6	IC53	CVITC74VCX541FT	I.C , OCTAL BUS BUFFER (TOSHIBA)		1
....6	IC54	HVITC74VHC157FT	I.C , 2-CHANNEL MUX (TOSHIBA)		1
....6	IC55	CVICS497024CVZ	I.C , DSP (CIRRUS LOGIC)		1
....6	L701	CLZ9Z014Z	FERRITE , CHIP BEAD(60ohm, 4516)	HCB4516KF-600T60	1
....6	L702	CLZ9Z014Z	FERRITE , CHIP BEAD(60ohm, 4516)	HCB4516KF-600T60	1
....6	L703	CLZ9Z014Z	FERRITE , CHIP BEAD(60ohm, 4516)	HCB4516KF-600T60	1
....6	L704	CLZ9R005Z	FERRITE , CHIP BEAD(60ohm, 1608)	HCB1608KF-600T30	1
....6	L705	CLZ9R005Z	FERRITE , CHIP BEAD(60ohm, 1608)	HCB1608KF-600T30	1
....6	Q307	HVTKRA107S	TR, CHIP		1
....6	Q729	HVTKRC107S	T.R , CHIP		1
....6	Q730	HVTKRC107S	T.R , CHIP		1
....6	Q731	HVTKRA107S	TR, CHIP		1
....6	Q732	HVTKRA107S	TR, CHIP		1
....6	Q734	HVTKRA107S	TR, CHIP		1
....6	Q738	CVTKRC103S	T.R , CHIP		1
....6	Q741	HVTKRC107S	T.R , CHIP		1
....6	Q742	HVTKRA107S	TR, CHIP		1
....6	Q951	HVTKRC107S	T.R , CHIP		1
....6	Q952	HVTKRA107S	TR, CHIP		1
....6	Q991	HVTKRC107S	T.R , CHIP		1
....6	Q992	HVTKRA107S	TR, CHIP		1
....6	RN60	CRJ104DJ102T	RES , 4 ARRAY CHIP(1K, 1608X4)		1
....6	RN61	CRJ104DJ103T	RES, ARRAY, 10K (1608)	10K(1608)	1
....6	RN63	CRJ104DJ103T	RES, ARRAY, 10K (1608)	10K(1608)	1
....6	RN64	CRJ104DJ101T	RES , CHIP NETWORK(1/16W, 100ohm, 1608X	100R (1608)	1
....6	RN65	CRJ104DJ101T	RES , CHIP NETWORK(1/16W, 100ohm, 1608X	100R (1608)	1
....6	RN66	CRJ104DJ101T	RES , CHIP NETWORK(1/16W, 100ohm, 1608X	100R (1608)	1
....6	RN73	CRJ104DJ103T	RES, ARRAY, 10K (1608)	10K(1608)	1
....6	RN76	CRJ104DJ330T	RES, 4ARRAY (1608*4)	33 OHM/1608*4	1
....6	RN77	CRJ104DJ330T	RES, 4ARRAY (1608*4)	33 OHM/1608*4	1
....6	RN78	CRJ104DJ330T	RES, 4ARRAY (1608*4)	33 OHM/1608*4	1
....6	RN79	CRJ104DJ330T	RES, 4ARRAY (1608*4)	33 OHM/1608*4	1
....6	RN81	CRJ104DJ330T	RES, 4ARRAY (1608*4)	33 OHM/1608*4	1
....6	RN82	CRJ104DJ330T	RES, 4ARRAY (1608*4)	33 OHM/1608*4	1
....6	RN83	CRJ104DJ330T	RES, 4ARRAY (1608*4)	33 OHM/1608*4	1
....6	RN84	CRJ104DJ330T	RES, 4ARRAY (1608*4)	33 OHM/1608*4	1
....6	RN85	CRJ104DJ330T	RES, 4ARRAY (1608*4)	33 OHM/1608*4	1
....6	RN87	CRJ104DJ330T	RES, 4ARRAY (1608*4)	33 OHM/1608*4	1
....6	RN88	CRJ104DJ103T	RES, ARRAY, 10K (1608)	10K(1608)	1
....6	RN89	CRJ104DJ103T	RES, ARRAY, 10K (1608)	10K(1608)	1
....6	RN90	CRJ104DJ330T	RES, 4ARRAY (1608*4)	33 OHM/1608*4	1
....6	RN91	CRJ104DJ330T	RES, 4ARRAY (1608*4)	33 OHM/1608*4	1
....6	RN92	CRJ104DJ101T	RES , CHIP NETWORK(1/16W, 100ohm, 1608X	100R (1608)	1
....6	RN93	CRJ104DJ330T	RES, 4ARRAY (1608*4)	33 OHM/1608*4	1
....6	R130	CRJ10DJ473T	RES , CHIP (47K OHM)	1608 SIZE	1
....6	R131	CRJ10DJ220T	RES , CHIP (22 OHM)	1608 SIZE	1
....6	R132	CRJ10DJ220T	RES , CHIP (22 OHM)	1608 SIZE	1
....6	R133	CRJ10DJ153T	RES , CHIP (15K OHM)		1
....6	R134	CRJ10DJ153T	RES , CHIP (15K OHM)		1
....6	R135	CRJ10DJ103T	RES , CHIP (10K OHM)	1608 SIZE	1
....6	R136	CRJ10DJ103T	RES , CHIP (10K OHM)	1608 SIZE	1
....6	R137	CRJ10DJ202T	RES , CHIP (2K OHM)		1
....6	R138	CRJ10DJ473T	RES , CHIP (47K OHM)	1608 SIZE	1
....6	R139	CRJ10DJ473T	RES , CHIP (47K OHM)	1608 SIZE	1
....6	R140	CRJ10DJ103T	RES , CHIP (10K OHM)	1608 SIZE	1
....6	R141	CRJ10DJ104T	RES , CHIP (100K OHM)	1608 SIZE	1
....6	R142	CRJ10DJ0R0T	RES , CHIP (O OHM)	1608 SIZE	1
....6	R149	CRJ10DJ104T	RES , CHIP (100K OHM)	1608 SIZE	1
....6	R150	CRJ10DJ104T	RES , CHIP (100K OHM)	1608 SIZE	1
....6	R151	CRJ10DJ103T	RES , CHIP (10K OHM)	1608 SIZE	1
....6	R152	CRJ10DJ103T	RES , CHIP (10K OHM)	1608 SIZE	1
....6	R153	CRJ10DJ103T	RES , CHIP (10K OHM)	1608 SIZE	1
....6	R154	CRJ10DJ103T	RES , CHIP (10K OHM)	1608 SIZE	1
....6	R155	CRJ10DJ103T	RES , CHIP (10K OHM)	1608 SIZE	1
....6	R156	CRJ10DJ101T	RES , CHIP (100 OHM)	1608 SIZE	1
....6	R157	CRJ10DJ103T	RES , CHIP (10K OHM)	1608 SIZE	1

INPUT PCB ASSY					
Level	Ref. #	Part Number	Description	Drawing No (Value)	Qty
....6	R158	CRJ10DJ102T	RES , CHIP (1K OHM)	1608 SIZE	1
....6	R159	CRJ10DJ102T	RES , CHIP (1K OHM)	1608 SIZE	1
....6	R160	CRJ10DJ103T	RES , CHIP (10K OHM)	1608 SIZE	1
....6	R161	CRJ10DJ104T	RES , CHIP (100K OHM)	1608 SIZE	1
....6	R162	CRJ10DJ102T	RES , CHIP (1K OHM)	1608 SIZE	1
....6	R163	CRJ10DJ104T	RES , CHIP (100K OHM)	1608 SIZE	1
....6	R164	CRJ10DJ104T	RES , CHIP (100K OHM)	1608 SIZE	1
....6	R165	CRJ10DJ104T	RES , CHIP (100K OHM)	1608 SIZE	1
....6	R166	CRJ10DJ0R0T	RES , CHIP (O OHM)	1608 SIZE	1
....6	R167	CRJ10DJ0R0T	RES , CHIP (O OHM)	1608 SIZE	1
....6	R168	CRJ10DJ0R0T	RES , CHIP (O OHM)	1608 SIZE	1
....6	R169	CRJ10DJ103T	RES , CHIP (10K OHM)	1608 SIZE	1
....6	R170	CRJ10DJ103T	RES , CHIP (10K OHM)	1608 SIZE	1
....6	R172	CRJ10DJ103T	RES , CHIP (10K OHM)	1608 SIZE	1
....6	R201	CRJ10DJ221T	RES , CHIP (220 OHM)	1608 SIZE	1
....6	R202	CRJ10DJ221T	RES , CHIP (220 OHM)	1608 SIZE	1
....6	R203	CRJ10DJ221T	RES , CHIP (220 OHM)	1608 SIZE	1
....6	R204	CRJ10DJ221T	RES , CHIP (220 OHM)	1608 SIZE	1
....6	R205	CRJ10DJ221T	RES , CHIP (220 OHM)	1608 SIZE	1
....6	R206	CRJ10DJ221T	RES , CHIP (220 OHM)	1608 SIZE	1
....6	R207	CRJ10DJ221T	RES , CHIP (220 OHM)	1608 SIZE	1
....6	R208	CRJ10DJ221T	RES , CHIP (220 OHM)	1608 SIZE	1
....6	R209	CRJ10DJ221T	RES , CHIP (220 OHM)	1608 SIZE	1
....6	R210	CRJ10DJ221T	RES , CHIP (220 OHM)	1608 SIZE	1
....6	R211	CRJ10DJ221T	RES , CHIP (220 OHM)	1608 SIZE	1
....6	R212	CRJ10DJ221T	RES , CHIP (220 OHM)	1608 SIZE	1
....6	R213	CRJ10DJ221T	RES , CHIP (220 OHM)	1608 SIZE	1
....6	R214	CRJ10DJ221T	RES , CHIP (220 OHM)	1608 SIZE	1
....6	R215	CRJ10DJ221T	RES , CHIP (220 OHM)	1608 SIZE	1
....6	R216	CRJ10DJ221T	RES , CHIP (220 OHM)	1608 SIZE	1
....6	R219	CRJ10DJ221T	RES , CHIP (220 OHM)	1608 SIZE	1
....6	R220	CRJ10DJ221T	RES , CHIP (220 OHM)	1608 SIZE	1
....6	R221	CRJ10DJ221T	RES , CHIP (220 OHM)	1608 SIZE	1
....6	R222	CRJ10DJ221T	RES , CHIP (220 OHM)	1608 SIZE	1
....6	R223	CRJ10DJ221T	RES , CHIP (220 OHM)	1608 SIZE	1
....6	R224	CRJ10DJ272T	RES , CHIP (2.7K OHM)	1608 SIZE	1
....6	R225	CRJ10DJ221T	RES , CHIP (220 OHM)	1608 SIZE	1
....6	R226	CRJ10DJ221T	RES , CHIP (220 OHM)	1608 SIZE	1
....6	R227	CRJ10DJ104T	RES , CHIP (100K OHM)	1608 SIZE	1
....6	R228	CRJ10DJ104T	RES , CHIP (100K OHM)	1608 SIZE	1
....6	R229	CRJ10DJ104T	RES , CHIP (100K OHM)	1608 SIZE	1
....6	R230	CRJ10DJ104T	RES , CHIP (100K OHM)	1608 SIZE	1
....6	R231	CRJ10DJ104T	RES , CHIP (100K OHM)	1608 SIZE	1
....6	R232	CRJ10DJ104T	RES , CHIP (100K OHM)	1608 SIZE	1
....6	R233	CRJ10DJ104T	RES , CHIP (100K OHM)	1608 SIZE	1
....6	R234	CRJ10DJ104T	RES , CHIP (100K OHM)	1608 SIZE	1
....6	R235	CRJ10DJ104T	RES , CHIP (100K OHM)	1608 SIZE	1
....6	R236	CRJ10DJ104T	RES , CHIP (100K OHM)	1608 SIZE	1
....6	R237	CRJ10DJ104T	RES , CHIP (100K OHM)	1608 SIZE	1
....6	R238	CRJ10DJ104T	RES , CHIP (100K OHM)	1608 SIZE	1
....6	R239	CRJ10DJ104T	RES , CHIP (100K OHM)	1608 SIZE	1
....6	R240	CRJ10DJ104T	RES , CHIP (100K OHM)	1608 SIZE	1
....6	R241	CRJ10DJ104T	RES , CHIP (100K OHM)	1608 SIZE	1
....6	R242	CRJ10DJ104T	RES , CHIP (100K OHM)	1608 SIZE	1
....6	R245	CRJ10DJ104T	RES , CHIP (100K OHM)	1608 SIZE	1
....6	R246	CRJ10DJ104T	RES , CHIP (100K OHM)	1608 SIZE	1
....6	R247	CRJ10DJ104T	RES , CHIP (100K OHM)	1608 SIZE	1
....6	R248	CRJ10DJ104T	RES , CHIP (100K OHM)	1608 SIZE	1
....6	R249	CRJ10DJ104T	RES , CHIP (100K OHM)	1608 SIZE	1
....6	R250	CRJ10DJ103T	RES , CHIP (10K OHM)	1608 SIZE	1
....6	R251	CRJ10DJ104T	RES , CHIP (100K OHM)	1608 SIZE	1
....6	R252	CRJ10DJ104T	RES , CHIP (100K OHM)	1608 SIZE	1
....6	R253	CRJ10DJ4R7T	RES , CHIP (4.7 OHM)	1608 SIZE	1
....6	R254	CRJ10DJ4R7T	RES , CHIP (4.7 OHM)	1608 SIZE	1
....6	R255	CRJ10DJ4R7T	RES , CHIP (4.7 OHM)	1608 SIZE	1
....6	R256	CRJ10DJ4R7T	RES , CHIP (4.7 OHM)	1608 SIZE	1
....6	R257	CRJ10DJ4R7T	RES , CHIP (4.7 OHM)	1608 SIZE	1
....6	R259	CRJ10DJ4R7T	RES , CHIP (4.7 OHM)	1608 SIZE	1
....6	R260	CRJ10DJ4R7T	RES , CHIP (4.7 OHM)	1608 SIZE	1
....6	R261	CRJ10DJ184T	RES , CHIP (180K OHM)	1608 SIZE	1
....6	R262	CRJ10DJ184T	RES , CHIP (180K OHM)	1608 SIZE	1
....6	R263	CRJ10DJ184T	RES , CHIP (180K OHM)	1608 SIZE	1
....6	R264	CRJ10DJ184T	RES , CHIP (180K OHM)	1608 SIZE	1
....6	R265	CRJ10DJ184T	RES , CHIP (180K OHM)	1608 SIZE	1
....6	R266	CRJ10DJ184T	RES , CHIP (180K OHM)	1608 SIZE	1
....6	R267	CRJ10DJ184T	RES , CHIP (180K OHM)	1608 SIZE	1
....6	R268	CRJ10DJ184T	RES , CHIP (180K OHM)	1608 SIZE	1
....6	R271	CRJ10DJ242T	RES , CHIP (2.4K OHM)	1608 SIZE	1
....6	R272	CRJ10DJ242T	RES , CHIP (2.4K OHM)	1608 SIZE	1



INPUT PCB ASSY					
Level	Ref. #	Part Number	Description	Drawing No (Value)	Qty
....6	R273	CRJ10DJ242T	RES , CHIP (2.4K OHM)	1608 SIZE	1
....6	R274	CRJ10DJ222T	RES , CHIP (2.2K OHM)	1608 SIZE	1
....6	R275	CRJ10DJ242T	RES , CHIP (2.4K OHM)	1608 SIZE	1
....6	R276	CRJ10DJ242T	RES , CHIP (2.4K OHM)	1608 SIZE	1
....6	R277	CRJ10DJ242T	RES , CHIP (2.4K OHM)	1608 SIZE	1
....6	R278	CRJ10DJ242T	RES , CHIP (2.4K OHM)	1608 SIZE	1
....6	R279	CRJ10DJ101T	RES , CHIP (100 OHM)	1608 SIZE	1
....6	R280	CRJ10DJ101T	RES , CHIP (100 OHM)	1608 SIZE	1
....6	R281	CRJ10DJ512T	RES , CHIP (5.1K OHM)	1608 SIZE	1
....6	R282	CRJ10DJ512T	RES , CHIP (5.1K OHM)	1608 SIZE	1
....6	R283	CRJ10DJ512T	RES , CHIP (5.1K OHM)	1608 SIZE	1
....6	R284	CRJ10DJ912T	RES , CHIP	9.1K OHM/1608	1
....6	R285	CRJ10DJ512T	RES , CHIP (5.1K OHM)	1608 SIZE	1
....6	R286	CRJ10DJ512T	RES , CHIP (5.1K OHM)	1608 SIZE	1
....6	R287	CRJ10DJ512T	RES , CHIP (5.1K OHM)	1608 SIZE	1
....6	R288	CRJ10DJ512T	RES , CHIP (5.1K OHM)	1608 SIZE	1
....6	R289	CRJ10DJ101T	RES , CHIP (100 OHM)	1608 SIZE	1
....6	R290	CRJ10DJ101T	RES , CHIP (100 OHM)	1608 SIZE	1
....6	R291	CRJ10DJ184T	RES , CHIP (180K OHM)	1608 SIZE	1
....6	R292	CRJ10DJ184T	RES , CHIP (180K OHM)	1608 SIZE	1
....6	R293	CRJ10DJ184T	RES , CHIP (180K OHM)	1608 SIZE	1
....6	R294	CRJ10DJ184T	RES , CHIP (180K OHM)	1608 SIZE	1
....6	R295	CRJ10DJ184T	RES , CHIP (180K OHM)	1608 SIZE	1
....6	R296	CRJ10DJ184T	RES , CHIP (180K OHM)	1608 SIZE	1
....6	R297	CRJ10DJ184T	RES , CHIP (180K OHM)	1608 SIZE	1
....6	R298	CRJ10DJ184T	RES , CHIP (180K OHM)	1608 SIZE	1
....6	R301	CRJ10DJ122T	RES , CHIP (1.2K OHM)	1608 SIZE	1
....6	R302	CRJ10DJ122T	RES , CHIP (1.2K OHM)	1608 SIZE	1
....6	R303	CRJ10DJ122T	RES , CHIP (1.2K OHM)	1608 SIZE	1
....6	R304	CRJ10DJ122T	RES , CHIP (1.2K OHM)	1608 SIZE	1
....6	R305	CRJ10DJ272T	RES , CHIP (2.7K OHM)	1608 SIZE	1
....6	R306	CRJ10DJ272T	RES , CHIP (2.7K OHM)	1608 SIZE	1
....6	R307	CRJ10DJ272T	RES , CHIP (2.7K OHM)	1608 SIZE	1
....6	R308	CRJ10DJ272T	RES , CHIP (2.7K OHM)	1608 SIZE	1
....6	R309	CRJ10DJ272T	RES , CHIP (2.7K OHM)	1608 SIZE	1
....6	R310	CRJ10DJ272T	RES , CHIP (2.7K OHM)	1608 SIZE	1
....6	R311	CRJ10DJ272T	RES , CHIP (2.7K OHM)	1608 SIZE	1
....6	R312	CRJ10DJ272T	RES , CHIP (2.7K OHM)	1608 SIZE	1
....6	R313	CRJ10DJ272T	RES , CHIP (2.7K OHM)	1608 SIZE	1
....6	R314	CRJ10DJ272T	RES , CHIP (2.7K OHM)	1608 SIZE	1
....6	R315	CRJ10DJ272T	RES , CHIP (2.7K OHM)	1608 SIZE	1
....6	R316	CRJ10DJ272T	RES , CHIP (2.7K OHM)	1608 SIZE	1
....6	R317	CRJ10DJ561T	RES , CHIP		1
....6	R318	CRJ10DJ392T	RES , CHIP (3.9K OHM)		1
....6	R321	CRJ10DJ512T	RES , CHIP (5.1K OHM)	1608 SIZE	1
....6	R322	CRJ10DJ122T	RES , CHIP (1.2K OHM)	1608 SIZE	1
....6	R323	CRJ10DJ122T	RES , CHIP (1.2K OHM)	1608 SIZE	1
....6	R324	CRJ10DJ512T	RES , CHIP (5.1K OHM)	1608 SIZE	1
....6	R325	CRJ10DJ512T	RES , CHIP (5.1K OHM)	1608 SIZE	1
....6	R326	CRJ10DJ122T	RES , CHIP (1.2K OHM)	1608 SIZE	1
....6	R327	CRJ10DJ122T	RES , CHIP (1.2K OHM)	1608 SIZE	1
....6	R328	CRJ10DJ103T	RES , CHIP (10K OHM)	1608 SIZE	1
....6	R329	CRJ10DJ512T	RES , CHIP (5.1K OHM)	1608 SIZE	1
....6	R330	CRJ10DJ122T	RES , CHIP (1.2K OHM)	1608 SIZE	1
....6	R331	CRJ10DJ122T	RES , CHIP (1.2K OHM)	1608 SIZE	1
....6	R332	CRJ10DJ512T	RES , CHIP (5.1K OHM)	1608 SIZE	1
....6	R333	CRJ10DJ512T	RES , CHIP (5.1K OHM)	1608 SIZE	1
....6	R334	CRJ10DJ122T	RES , CHIP (1.2K OHM)	1608 SIZE	1
....6	R335	CRJ10DJ122T	RES , CHIP (1.2K OHM)	1608 SIZE	1
....6	R336	CRJ10DJ512T	RES , CHIP (5.1K OHM)	1608 SIZE	1
....6	R337	CRJ10DJ104T	RES , CHIP (100K OHM)	1608 SIZE	1
....6	R338	CRJ10DJ102T	RES , CHIP (1K OHM)	1608 SIZE	1
....6	R340	CRJ10DJ472T	RES , CHIP (4.7K OHM)	1608 SIZE	1
....6	R341	CRJ10DJ122T	RES , CHIP (1.2K OHM)	1608 SIZE	1
....6	R344	CRJ10DJ122T	RES , CHIP (1.2K OHM)	1608 SIZE	1
....6	R345	CRJ10DJ122T	RES , CHIP (1.2K OHM)	1608 SIZE	1
....6	R348	CRJ10DJ122T	RES , CHIP (1.2K OHM)	1608 SIZE	1
....6	R349	CRJ10DJ122T	RES , CHIP (1.2K OHM)	1608 SIZE	1
....6	R352	CRJ10DJ122T	RES , CHIP (1.2K OHM)	1608 SIZE	1
....6	R353	CRJ10DJ122T	RES , CHIP (1.2K OHM)	1608 SIZE	1
....6	R354	CRJ10DJ301T	RES , CHIP	1608	1
....6	R355	CRJ10DJ273T	RES , CHIP (27K OHM)		1
....6	R356	CRJ10DJ122T	RES , CHIP (1.2K OHM)	1608 SIZE	1
....6	R361	CRJ10DJ104T	RES , CHIP (100K OHM)	1608 SIZE	1
....6	R362	CRJ10DJ104T	RES , CHIP (100K OHM)	1608 SIZE	1
....6	R363	CRJ10DJ104T	RES , CHIP (100K OHM)	1608 SIZE	1
....6	R364	CRJ10DJ104T	RES , CHIP (100K OHM)	1608 SIZE	1
....6	R365	CRJ10DJ104T	RES , CHIP (100K OHM)	1608 SIZE	1
....6	R366	CRJ10DJ104T	RES , CHIP (100K OHM)	1608 SIZE	1

INPUT PCB ASSY					
Level	Ref. #	Part Number	Description	Drawing No (Value)	Qty
....6	R367	CRJ10DJ104T	RES , CHIP (100K OHM)	1608 SIZE	1
....6	R368	CRJ10DJ104T	RES , CHIP (100K OHM)	1608 SIZE	1
....6	R369	CRJ10DJ301T	RES , CHIP	1608	1
....6	R370	CRJ10DJ273T	RES , CHIP (27K OHM)		1
....6	R371	CRJ10DJ512T	RES , CHIP (5.1K OHM)	1608 SIZE	1
....6	R372	CRJ10DJ512T	RES , CHIP (5.1K OHM)	1608 SIZE	1
....6	R373	CRJ10DJ512T	RES , CHIP (5.1K OHM)	1608 SIZE	1
....6	R374	CRJ10DJ103T	RES , CHIP (10K OHM)	1608 SIZE	1
....6	R375	CRJ10DJ512T	RES , CHIP (5.1K OHM)	1608 SIZE	1
....6	R376	CRJ10DJ512T	RES , CHIP (5.1K OHM)	1608 SIZE	1
....6	R377	CRJ10DJ512T	RES , CHIP (5.1K OHM)	1608 SIZE	1
....6	R378	CRJ10DJ512T	RES , CHIP (5.1K OHM)	1608 SIZE	1
....6	R381	CRJ10DJ561T	RES , CHIP		1
....6	R382	CRJ10DJ561T	RES , CHIP		1
....6	R383	CRJ10DJ561T	RES , CHIP		1
....6	R384	CRJ10DJ561T	RES , CHIP		1
....6	R385	CRJ10DJ561T	RES , CHIP		1
....6	R386	CRJ10DJ561T	RES , CHIP		1
....6	R387	CRJ10DJ561T	RES , CHIP		1
....6	R388	CRJ10DJ561T	RES , CHIP		1
....6	R389	CRJ10DJ184T	RES , CHIP (180K OHM)	1608 SIZE	1
....6	R390	CRJ10DJ184T	RES , CHIP (180K OHM)	1608 SIZE	1
....6	R391	CRJ10DJ392T	RES , CHIP (3.9K OHM)		1
....6	R392	CRJ10DJ392T	RES , CHIP (3.9K OHM)		1
....6	R393	CRJ10DJ392T	RES , CHIP (3.9K OHM)		1
....6	R394	CRJ10DJ392T	RES , CHIP (3.9K OHM)		1
....6	R395	CRJ10DJ392T	RES , CHIP (3.9K OHM)		1
....6	R396	CRJ10DJ392T	RES , CHIP (3.9K OHM)		1
....6	R397	CRJ10DJ392T	RES , CHIP (3.9K OHM)		1
....6	R398	CRJ10DJ392T	RES , CHIP (3.9K OHM)		1
....6	R399	CRJ10DJ472T	RES , CHIP (4.7K OHM)	1608 SIZE	1
....6	R400	CRJ10DJ0R0T	RES , CHIP (O OHM)	1608 SIZE	1
....6	R401	CRJ10DJ0R0T	RES , CHIP (O OHM)	1608 SIZE	1
....6	R402	CRJ10DJ0R0T	RES , CHIP (O OHM)	1608 SIZE	1
....6	R445	CRJ10DJ102T	RES , CHIP (1K OHM)	1608 SIZE	1
....6	R531	CRJ10DJ152T	RES , CHIP (1.5K OHM)	1608 SIZE	1
....6	R532	CRJ10DJ152T	RES , CHIP (1.5K OHM)	1608 SIZE	1
....6	R533	CRJ10DJ152T	RES , CHIP (1.5K OHM)	1608 SIZE	1
....6	R534	CRJ10DJ152T	RES , CHIP (1.5K OHM)	1608 SIZE	1
....6	R704	CRJ10DJ103T	RES , CHIP (10K OHM)	1608 SIZE	1
....6	R711	CRJ10DJ560T	RES , CHIP (56 OHM)	1608 SIZE	1
....6	R712	CRJ10DJ820T	RES , CHIP (82 OHM)	1608 SIZE	1
....6	R714	CRJ10DJ104T	RES , CHIP (100K OHM)	1608 SIZE	1
....6	R715	CRJ10DJ104T	RES , CHIP (100K OHM)	1608 SIZE	1
....6	R716	CRJ10DJ472T	RES , CHIP (4.7K OHM)	1608 SIZE	1
....6	R717	CRJ10DJ0R0T	RES , CHIP (O OHM)	1608 SIZE	1
....6	R718	CRJ10DJ332T	RES , CHIP (3.3K OHM)	1608 SIZE	1
....6	R719	CRJ10DJ0R0T	RES , CHIP (O OHM)	1608 SIZE	1
....6	R720	CRJ10DJ0R0T	RES , CHIP (O OHM)	1608 SIZE	1
....6	R721	CRJ10DJ330T	RES , CHIP (33 OHM)	1608 SIZE	1
....6	R724	CRJ10DJ101T	RES , CHIP (100 OHM)	1608 SIZE	1
....6	R725	CRJ10DJ0R0T	RES , CHIP (O OHM)	1608 SIZE	1
....6	R726	CRJ10DJ100T	RES , CHIP (10 OHM)	1608 SIZE	1
....6	R727	CRJ10DJ0R0T	RES , CHIP (O OHM)	1608 SIZE	1
....6	R728	CRJ10DJ102T	RES , CHIP (1K OHM)	1608 SIZE	1
....6	R732	CRJ10DJ103T	RES , CHIP (10K OHM)	1608 SIZE	1
....6	R733	CRJ10DJ100T	RES , CHIP (10 OHM)	1608 SIZE	1
....6	R736	CRJ10DJ241T	RES , CHIP (240 OHM)		1
....6	R737	CRJ10DJ330T	RES , CHIP (33 OHM)	1608 SIZE	1
....6	R739	CRJ10DJ0R0T	RES , CHIP (O OHM)	1608 SIZE	1
....6	R740	CRJ10DJ121T	RES , CHIP (120 OHM)	1608 SIZE	1
....6	R741	CRJ10DJ330T	RES , CHIP (33 OHM)	1608 SIZE	1
....6	R742	CRJ10DJ330T	RES , CHIP (33 OHM)	1608 SIZE	1
....6	R743	CRJ10DJ330T	RES , CHIP (33 OHM)	1608 SIZE	1
....6	R747	CRJ10DJ330T	RES , CHIP (33 OHM)	1608 SIZE	1
....6	R748	CRJ10DJ330T	RES , CHIP (33 OHM)	1608 SIZE	1
....6	R751	CRJ10DJ820T	RES , CHIP (82 OHM)	1608 SIZE	1
....6	R752	CRJ10DJ330T	RES , CHIP (33 OHM)	1608 SIZE	1
....6	R753	CRJ10DJ103T	RES , CHIP (10K OHM)	1608 SIZE	1
....6	R754	CRJ10DJ103T	RES , CHIP (10K OHM)	1608 SIZE	1
....6	R755	CRJ10DJ750T	RES , CHIP (75 OHM)	1608 SIZE	1
....6	R756	CRJ10DJ750T	RES , CHIP (75 OHM)	1608 SIZE	1
....6	R757	CRJ10DJ750T	RES , CHIP (75 OHM)	1608 SIZE	1
....6	R759	CRJ10DJ331T	RES , CHIP (330 OHM)		1
....6	R760	CRJ10DJ105T	RES , CHIP (1M OHM)	1608 SIZE	1
....6	R761	CRJ10DJ102T	RES , CHIP (1K OHM)	1608 SIZE	1
....6	R762	CRJ10DJ102T	RES , CHIP (1K OHM)	1608 SIZE	1
....6	R763	CRJ10DJ472T	RES , CHIP (4.7K OHM)	1608 SIZE	1
....6	R764	CRJ10DJ330T	RES , CHIP (33 OHM)	1608 SIZE	1

INPUT PCB ASSY					
Level	Ref. #	Part Number	Description	Drawing No (Value)	Qty
....6	R765	CRJ10DJ330T	RES , CHIP (33 OHM)	1608 SIZE	1
....6	R767	CRJ10DF5101T	RES. CHIP (5.1K 1%)	1608 SIZE	1
....6	R768	CRJ10DJ0R0T	RES , CHIP (0 OHM)	1608 SIZE	1
....6	R773	CRJ10DJ332T	RES , CHIP (3.3K OHM)	1608 SIZE	1
....6	R774	CRJ10DJ332T	RES , CHIP (3.3K OHM)	1608 SIZE	1
....6	R775	CRJ10DJ332T	RES , CHIP (3.3K OHM)	1608 SIZE	1
....6	R776	CRJ10DJ332T	RES , CHIP (3.3K OHM)	1608 SIZE	1
....6	R777	CRJ10DJ101T	RES , CHIP (100 OHM)	1608 SIZE	1
....6	R782	CRJ10DJ272T	RES , CHIP (2.7K OHM)	1608 SIZE	1
....6	R783	CRJ10DJ272T	RES , CHIP (2.7K OHM)	1608 SIZE	1
....6	R784	CRJ10DJ473T	RES , CHIP (47K OHM)	1608 SIZE	1
....6	R785	CRJ10DJ104T	RES , CHIP (100K OHM)	1608 SIZE	1
....6	R786	CRJ10DJ105T	RES , CHIP (1M OHM)	1608 SIZE	1
....6	R788	CRJ10DJ103T	RES , CHIP (10K OHM)	1608 SIZE	1
....6	R789	CRJ10DJ103T	RES , CHIP (10K OHM)	1608 SIZE	1
....6	R792	CRJ10DJ103T	RES , CHIP (10K OHM)	1608 SIZE	1
....6	R800	CRJ10DJ332T	RES , CHIP (3.3K OHM)	1608 SIZE	1
....6	R801	CRJ10DJ332T	RES , CHIP (3.3K OHM)	1608 SIZE	1
....6	R810	CRJ10DJ103T	RES , CHIP (10K OHM)	1608 SIZE	1
....6	R811	CRJ10DJ103T	RES , CHIP (10K OHM)	1608 SIZE	1
....6	R812	CRJ10DJ103T	RES , CHIP (10K OHM)	1608 SIZE	1
....6	R813	CRJ10DJ330T	RES , CHIP (33 OHM)	1608 SIZE	1
....6	R814	CRJ10DJ330T	RES , CHIP (33 OHM)	1608 SIZE	1
....6	R815	CRJ10DJ330T	RES , CHIP (33 OHM)	1608 SIZE	1
....6	R816	CRJ10DJ330T	RES , CHIP (33 OHM)	1608 SIZE	1
....6	R910	CRJ10DJ105T	RES , CHIP (1M OHM)	1608 SIZE	1
....6	R932	CRJ10DJ103T	RES , CHIP (10K OHM)	1608 SIZE	1
....6	R960	CRJ10DJ332T	RES , CHIP (3.3K OHM)	1608 SIZE	1
....6	R963	CRJ10DJ105T	RES , CHIP (1M OHM)	1608 SIZE	1
....6	R966	CRJ10DJ472T	RES , CHIP (4.7K OHM)	1608 SIZE	1
....6	R992	CRJ10DJ562T	RES , CHIP (5.6K OHM)	1608 SIZE	1
....5	C250	CCEA1CH101T	CAP , ELECT	100UF 16V	1
....5	C251	CCEA1HH100T	CAP , ELECT	10UF 50V	1
....5	C261	CCEA1EH470T	CAP , ELECT	47UF 25V	1
....5	C262	CCEA1EH470T	CAP , ELECT	47UF 25V	1
....5	C263	CCEA1EH470T	CAP , ELECT	47UF 25V	1
....5	C264	CCEA1EH470T	CAP , ELECT	47UF 25V	1
....5	C265	CCEA1EH470T	CAP , ELECT	47UF 25V	1
....5	C266	CCEA1EH470T	CAP , ELECT	47UF 25V	1
....5	C267	CCEA1EH470T	CAP , ELECT	47UF 25V	1
....5	C268	CCEA1EH470T	CAP , ELECT	47UF 25V	1
....5	C270	CCEA1HH100T	CAP , ELECT	10UF 50V	1
....5	C271	CCEA1HH100T	CAP , ELECT	10UF 50V	1
....5	C272	CCEA1HH100T	CAP , ELECT	10UF 50V	1
....5	C273	CCEA1HH100T	CAP , ELECT	10UF 50V	1
....5	C275	CCEA1HH100T	CAP , ELECT	10UF 50V	1
....5	C276	CCEA1HH100T	CAP , ELECT	10UF 50V	1
....5	C281	CCEA1HH100T	CAP , ELECT	10UF 50V	1
....5	C282	CCEA1HH100T	CAP , ELECT	10UF 50V	1
....5	C283	CCEA1HH100T	CAP , ELECT	10UF 50V	1
....5	C284	CCEA1HH100T	CAP , ELECT	10UF 50V	1
....5	C285	CCEA1HH100T	CAP , ELECT	10UF 50V	1
....5	C286	CCEA1HH100T	CAP , ELECT	10UF 50V	1
....5	C287	CCEA1HH100T	CAP , ELECT	10UF 50V	1
....5	C288	CCEA1HH100T	CAP , ELECT	10UF 50V	1
....5	C292	CCEA1CH101T	CAP , ELECT	100UF 16V	1
....5	C294	CCEA1CH101T	CAP , ELECT	100UF 16V	1
....5	C341	CCEA1HH100T	CAP , ELECT	10UF 50V	1
....5	C342	CCEA1HH100T	CAP , ELECT	10UF 50V	1
....5	C343	CCEA1HH100T	CAP , ELECT	10UF 50V	1
....5	C344	CCEA1HH100T	CAP , ELECT	10UF 50V	1
....5	C345	CCEA1HH100T	CAP , ELECT	10UF 50V	1
....5	C346	CCEA1HH100T	CAP , ELECT	10UF 50V	1
....5	C347	CCEA1HH100T	CAP , ELECT	10UF 50V	1
....5	C348	CCEA1HH100T	CAP , ELECT	10UF 50V	1
....5	C349	CCEA1CH101T	CAP , ELECT	100UF 16V	1
....5	C358	CCEA1CH101T	CAP , ELECT	100UF 16V	1
....5	C359	CCEA1CH101T	CAP , ELECT	100UF 16V	1
....5	C360	CCEA1CH101T	CAP , ELECT	100UF 16V	1
....5	C361	CCEA1CH101T	CAP , ELECT	100UF 16V	1
....5	C371	CCEA1HH100T	CAP , ELECT	10UF 50V	1
....5	C372	CCEA1HH100T	CAP , ELECT	10UF 50V	1
....5	C373	CCEA1HH100T	CAP , ELECT	10UF 50V	1
....5	C374	CCEA1HH100T	CAP , ELECT	10UF 50V	1
....5	C375	CCEA1HH100T	CAP , ELECT	10UF 50V	1
....5	C376	CCEA1HH100T	CAP , ELECT	10UF 50V	1
....5	C377	CCEA1HH100T	CAP , ELECT	10UF 50V	1
....5	C378	CCEA1HH100T	CAP , ELECT	10UF 50V	1



HDMI PCB ASSY					
Level	Ref. #	Part Number	Description	Drawing No (Value)	Qty
....5	BN15	CJP17GA193ZY	WAFER, CARD CABLE (SMD)		1
....5	C801	CCUS1H104KC	CAP , CHIP	0.1UF 50V K	1
....5	C802	CCUS1H104KC	CAP , CHIP	0.1UF 50V K	1
....5	C803	CCUS1H104KC	CAP , CHIP	0.1UF 50V K	1
....5	C804	CCUS1H104KC	CAP , CHIP	0.1UF 50V K	1
....5	C805	CCSNA1C100B	CAP , CHIP TANTAL(10uF/16V, NingXia XingRi	XRCA45 XXX M XXX AT	1
....5	C806	CCUS1H104KC	CAP , CHIP	0.1UF 50V K	1
....5	C807	CCUS1H510JA	CAP , CHIP (51PF)		1
....5	C808	CCUS1H510JA	CAP , CHIP (51PF)		1
....5	C809	CCUS1H102KC	CAP , CHIP	1000PF 50V K	1
....5	C810	CCUS1H104KC	CAP , CHIP	0.1UF 50V K	1
....5	C811	CCUS1H104KC	CAP , CHIP	0.1UF 50V K	1
....5	C812	CCUS1H104KC	CAP , CHIP	0.1UF 50V K	1
....5	C813	CCUS1H104KC	CAP , CHIP	0.1UF 50V K	1
....5	C814	CCSNA1C100B	CAP , CHIP TANTAL(10uF/16V, NingXia XingRi	XRCA45 XXX M XXX AT	1
....5	C815	CCUS1H104KC	CAP , CHIP	0.1UF 50V K	1
....5	C816	CCUS1H104KC	CAP , CHIP	0.1UF 50V K	1
....5	C817	CCUS1H104KC	CAP , CHIP	0.1UF 50V K	1
....5	C818	CCUS1H104KC	CAP , CHIP	0.1UF 50V K	1
....5	C819	CCUS1H103KC	CAP , CHIP	0.01UF 50V K	1
....5	C820	CCSNA1C100B	CAP , CHIP TANTAL(10uF/16V, NingXia XingRi	XRCA45 XXX M XXX AT	1
....5	C821	CCSNA1C100B	CAP , CHIP TANTAL(10uF/16V, NingXia XingRi	XRCA45 XXX M XXX AT	1
....5	C822	CCSNA1C100B	CAP , CHIP TANTAL(10uF/16V, NingXia XingRi	XRCA45 XXX M XXX AT	1
....5	C823	CCUS1H102KC	CAP , CHIP	1000PF 50V K	1
....5	C824	CCUS1H104KC	CAP , CHIP	0.1UF 50V K	1
....5	C825	CCSNA1C100B	CAP , CHIP TANTAL(10uF/16V, NingXia XingRi	XRCA45 XXX M XXX AT	1
....5	C826	CCUS1H104KC	CAP , CHIP	0.1UF 50V K	1
....5	C827	CCUS1H104KC	CAP , CHIP	0.1UF 50V K	1
....5	C828	CCUS1H104KC	CAP , CHIP	0.1UF 50V K	1
....5	C829	CCUS1H104KC	CAP , CHIP	0.1UF 50V K	1
....5	C831	CCUS1H104KC	CAP , CHIP	0.1UF 50V K	1
....5	C832	CCUS1H104KC	CAP , CHIP	0.1UF 50V K	1
....5	C833	CCUS1H104KC	CAP , CHIP	0.1UF 50V K	1
....5	C834	CCUS1H104KC	CAP , CHIP	0.1UF 50V K	1
....5	C835	CCUI1C104KC	CAP , CHIP(1005, 16V/0.1UF)		1
....5	C836	CCSNA0J220B	CAP , CHIP TANTAL(22uF/6.3V, NingXia XingRi	XRCA45 XXX M XXX AT	1
....5	C837	CCUS1H104KC	CAP , CHIP	0.1UF 50V K	1
....5	C838	CCUI1C104KC	CAP , CHIP(1005, 16V/0.1UF)		1
....5	C839	CCUI1C104KC	CAP , CHIP(1005, 16V/0.1UF)		1
....5	C840	CCUI1C104KC	CAP , CHIP(1005, 16V/0.1UF)		1
....5	C841	CCUI1C104KC	CAP , CHIP(1005, 16V/0.1UF)		1
....5	C842	CCUI1C104KC	CAP , CHIP(1005, 16V/0.1UF)		1
....5	C843	CCUI1C104KC	CAP , CHIP(1005, 16V/0.1UF)		1
....5	C844	CCUI1C104KC	CAP , CHIP(1005, 16V/0.1UF)		1
....5	C845	CCUI1C104KC	CAP , CHIP(1005, 16V/0.1UF)		1
....5	C846	CCUI1C104KC	CAP , CHIP(1005, 16V/0.1UF)		1
....5	C847	CCUI1C104KC	CAP , CHIP(1005, 16V/0.1UF)		1
....5	C848	CCUI1C104KC	CAP , CHIP(1005, 16V/0.1UF)		1
....5	C849	CCSNA0J220B	CAP , CHIP TANTAL(22uF/6.3V, NingXia XingRi	XRCA45 XXX M XXX AT	1
....5	C850	CCSNA1C100B	CAP , CHIP TANTAL(10uF/16V, NingXia XingRi	XRCA45 XXX M XXX AT	1
....5	C851	CCUS1H104KC	CAP , CHIP	0.1UF 50V K	1
....5	C852	CCUI1C104KC	CAP , CHIP(1005, 16V/0.1UF)		1
....5	C853	CCUI1C104KC	CAP , CHIP(1005, 16V/0.1UF)		1
....5	C854	CCUS1H104KC	CAP , CHIP	0.1UF 50V K	1
....5	C855	CCSNA0J220B	CAP , CHIP TANTAL(22uF/6.3V, NingXia XingRi	XRCA45 XXX M XXX AT	1
....5	C856	CCUI1C104KC	CAP , CHIP(1005, 16V/0.1UF)		1
....5	C857	CCUI1C104KC	CAP , CHIP(1005, 16V/0.1UF)		1
....5	C858	CCUI1C104KC	CAP , CHIP(1005, 16V/0.1UF)		1
....5	C859	CCUI1C104KC	CAP , CHIP(1005, 16V/0.1UF)		1
....5	C860	CCSNA0J220B	CAP , CHIP TANTAL(22uF/6.3V, NingXia XingRi	XRCA45 XXX M XXX AT	1
....5	C861	CCUI1C104KC	CAP , CHIP(1005, 16V/0.1UF)		1
....5	C862	CCUI1C104KC	CAP , CHIP(1005, 16V/0.1UF)		1
....5	C863	CCUI1C104KC	CAP , CHIP(1005, 16V/0.1UF)		1
....5	C864	CCUI1C104KC	CAP , CHIP(1005, 16V/0.1UF)		1
....5	C865	CCUI1C104KC	CAP , CHIP(1005, 16V/0.1UF)		1
....5	C866	CCSNA1C100B	CAP , CHIP TANTAL(10uF/16V, NingXia XingRi	XRCA45 XXX M XXX AT	1
....5	C867	CCUI1C104KC	CAP , CHIP(1005, 16V/0.1UF)		1
....5	C868	CCUI1C104KC	CAP , CHIP(1005, 16V/0.1UF)		1
....5	C869	CCUI1C104KC	CAP , CHIP(1005, 16V/0.1UF)		1
....5	C870	CCUI1C104KC	CAP , CHIP(1005, 16V/0.1UF)		1
....5	C871	CCUI1C104KC	CAP , CHIP(1005, 16V/0.1UF)		1
....5	C872	CCUI1C104KC	CAP , CHIP(1005, 16V/0.1UF)		1
....5	C873	CCUI1C104KC	CAP , CHIP(1005, 16V/0.1UF)		1
....5	C874	CCUS1H104KC	CAP , CHIP	0.1UF 50V K	1
....5	C875	CCSNA0J220B	CAP , CHIP TANTAL(22uF/6.3V, NingXia XingRi	XRCA45 XXX M XXX AT	1
....5	C876	CCUS1H104KC	CAP , CHIP	0.1UF 50V K	1
....5	C877	CCUS1H104KC	CAP , CHIP	0.1UF 50V K	1
....5	C878	CCSNA1C100B	CAP , CHIP TANTAL(10uF/16V, NingXia XingRi	XRCA45 XXX M XXX AT	1
....5	C879	CCSNA1C100B	CAP , CHIP TANTAL(10uF/16V, NingXia XingRi	XRCA45 XXX M XXX AT	1



HDMI PCB ASSY					
Level	Ref. #	Part Number	Description	Drawing No (Value)	Qty
....5	C880	CCUI1C104KC	CAP , CHIP(1005, 16V/0.1UF)		1
....5	C881	CCUI1C104KC	CAP , CHIP(1005, 16V/0.1UF)		1
....5	C882	CCUI1C104KC	CAP , CHIP(1005, 16V/0.1UF)		1
....5	C883	CCUI1C104KC	CAP , CHIP(1005, 16V/0.1UF)		1
....5	C884	CCUS1H104KC	CAP , CHIP	0.1UF 50V K	1
....5	C885	CCUC0J106KC	CAP , CHIP (10UF/6.3V K X5R 2012)		1
....5	C886	CCUS1H104KC	CAP , CHIP	0.1UF 50V K	1
....5	C887	CCUI1C104KC	CAP , CHIP(1005, 16V/0.1UF)		1
....5	C888	CCUI1C104KC	CAP , CHIP(1005, 16V/0.1UF)		1
....5	C889	CCUI1C104KC	CAP , CHIP(1005, 16V/0.1UF)		1
....5	C890	CCUI1C104KC	CAP , CHIP(1005, 16V/0.1UF)		1
....5	C891	CCUI1C104KC	CAP , CHIP(1005, 16V/0.1UF)		1
....5	C892	CCUI1C104KC	CAP , CHIP(1005, 16V/0.1UF)		1
....5	C893	CCUI1C104KC	CAP , CHIP(1005, 16V/0.1UF)		1
....5	C894	CCUI1C104KC	CAP , CHIP(1005, 16V/0.1UF)		1
....5	C895	CCUI1C104KC	CAP , CHIP(1005, 16V/0.1UF)		1
....5	C896	CCSNA0J220B	CAP , CHIP TANTAL(22uF/6.3V, NingXia XingR	XRCA45 XXX M XXX AT	1
....5	C897	CCSNA0J220B	CAP , CHIP TANTAL(22uF/6.3V, NingXia XingR	XRCA45 XXX M XXX AT	1
....5	C898	CCUI1C104KC	CAP , CHIP(1005, 16V/0.1UF)		1
....5	C899	CCUI1C104KC	CAP , CHIP(1005, 16V/0.1UF)		1
....5	C900	CCSNA0J220B	CAP , CHIP TANTAL(22uF/6.3V, NingXia XingR	XRCA45 XXX M XXX AT	1
....5	C901	CCSNA0J220B	CAP , CHIP TANTAL(22uF/6.3V, NingXia XingR	XRCA45 XXX M XXX AT	1
....5	C902	CCUS1H104KC	CAP , CHIP	0.1UF 50V K	1
....5	C903	CCUS1H104KC	CAP , CHIP	0.1UF 50V K	1
....5	C904	CCUS1H104KC	CAP , CHIP	0.1UF 50V K	1
....5	C905	CCSNA1C100B	CAP , CHIP TANTAL(10uF/16V, NingXia XingRi	XRCA45 XXX M XXX AT	1
....5	C907	CCUS1H104KC	CAP , CHIP	0.1UF 50V K	1
....5	C908	CCSNA0J220B	CAP , CHIP TANTAL(22uF/6.3V, NingXia XingR	XRCA45 XXX M XXX AT	1
....5	C909	CCSNA1C100B	CAP , CHIP TANTAL(10uF/16V, NingXia XingRi	XRCA45 XXX M XXX AT	1
....5	C910	CCSNA0J220B	CAP , CHIP TANTAL(22uF/6.3V, NingXia XingR	XRCA45 XXX M XXX AT	1
....5	C911	CCSNA0J220B	CAP , CHIP TANTAL(22uF/6.3V, NingXia XingR	XRCA45 XXX M XXX AT	1
....5	C912	CCUS1H104KC	CAP , CHIP	0.1UF 50V K	1
....5	C913	CCUS1H104KC	CAP , CHIP	0.1UF 50V K	1
....5	C914	CCSNA1C100B	CAP , CHIP TANTAL(10uF/16V, NingXia XingRi	XRCA45 XXX M XXX AT	1
....5	C915	CCUS1H104KC	CAP , CHIP	0.1UF 50V K	1
....5	C916	CCSNA0J220B	CAP , CHIP TANTAL(22uF/6.3V, NingXia XingR	XRCA45 XXX M XXX AT	1
....5	C917	CCSNA0J220B	CAP , CHIP TANTAL(22uF/6.3V, NingXia XingR	XRCA45 XXX M XXX AT	1
....5	C918	CCSNA1C100B	CAP , CHIP TANTAL(10uF/16V, NingXia XingRi	XRCA45 XXX M XXX AT	1
....5	C919	CCSNA0J220B	CAP , CHIP TANTAL(22uF/6.3V, NingXia XingR	XRCA45 XXX M XXX AT	1
....5	C920	CCUS1H104KC	CAP , CHIP	0.1UF 50V K	1
....5	C921	CCUS1H104KC	CAP , CHIP	0.1UF 50V K	1
....5	C922	CCSNA0J220B	CAP , CHIP TANTAL(22uF/6.3V, NingXia XingR	XRCA45 XXX M XXX AT	1
....5	D901	HVD1SR159-200	DIODE , RECTIFIER		1
....5	D902	HVD1SR159-200	DIODE , RECTIFIER		1
....5	D903	HVD1SR159-200	DIODE , RECTIFIER		1
....5	D904	HVD1SR159-200	DIODE , RECTIFIER		1
....5	IC101	CVIADV7604	IC , HDMI RX (BALL, BGA-260P) ANALOG DEVICE		1
....5	IC102	CVIADV7510	I.C , HDMI 1.3 TX(100P LPFQ) ANALOG DEVICE		1
....5	IC103	HVITC74HC4094FN	I.C (TOSHIBA)	TC74HC4094FN	1
....5	IC104	CVIKIA1117S50	I.C , REGULATOR(SOT-223)	KIA1117S50-RTK/P	1
....5	IC105	HVIKIA7809AF	I.C , REGULATOR	KIA7809AF	1
....5	IC106	CVINJM2845DL118	IC, NJM2845DL1-18(TE1) JRC		1
....5	IC107	CVITC74Vcx541FT	I.C , OCTAL BUS BUFFER (TOSHIBA)		1
....5	IC108	CVIKIA1117S33	I.C , REGULATOR(SOT-223)	KIA1117S/F33, SOT-223	1
....5	IC109	CVIKIA1117S18	I.C , REGULATOR(SOT-223)	KIA1117S/F18, SOT-223	1
....5	IC110	CVINJM2845DL118	IC, NJM2845DL1-18(TE1) JRC		1
....5	JK91	CJJ9H008Z	JACK , HDMI (TYPE-A,SMT-19P)	H050FS019G600BY	1
....5	JK92	CJJ9H008Z	JACK , HDMI (TYPE-A,SMT-19P)	H050FS019G600BY	1
....5	JK93	CJJ9H008Z	JACK , HDMI (TYPE-A,SMT-19P)	H050FS019G600BY	1
....5	JK94	CJJ9H008Z	JACK , HDMI (TYPE-A,SMT-19P)	H050FS019G600BY	1
....5	L801	CLZ9R009Z	CHOKE COIL, CHIP ( FOR HDMI )		1
....5	L802	CLZ9R009Z	CHOKE COIL, CHIP ( FOR HDMI )		1
....5	L803	CLZ9R009Z	CHOKE COIL, CHIP ( FOR HDMI )		1
....5	L804	CLZ9R009Z	CHOKE COIL, CHIP ( FOR HDMI )		1
....5	L805	CLZ9Z014Z	FERRITE , CHIP BEAD(60ohm, 4516)	HCB4516KF-600T60	1
....5	L806	CLZ9Z014Z	FERRITE , CHIP BEAD(60ohm, 4516)	HCB4516KF-600T60	1
....5	L807	CLZ9Z014Z	FERRITE , CHIP BEAD(60ohm, 4516)	HCB4516KF-600T60	1
....5	L808	CLZ9Z014Z	FERRITE , CHIP BEAD(60ohm, 4516)	HCB4516KF-600T60	1
....5	L809	CLZ9Z014Z	FERRITE , CHIP BEAD(60ohm, 4516)	HCB4516KF-600T60	1
....5	L810	CLZ9Z014Z	FERRITE , CHIP BEAD(60ohm, 4516)	HCB4516KF-600T60	1
....5	L811	CLZ9Z014Z	FERRITE , CHIP BEAD(60ohm, 4516)	HCB4516KF-600T60	1
....5	L812	CLZ9Z014Z	FERRITE , CHIP BEAD(60ohm, 4516)	HCB4516KF-600T60	1
....5	L813	CLZ9Z014Z	FERRITE , CHIP BEAD(60ohm, 4516)	HCB4516KF-600T60	1
....5	L814	CLZ9Z014Z	FERRITE , CHIP BEAD(60ohm, 4516)	HCB4516KF-600T60	1
....5	L815	CLZ9Z014Z	FERRITE , CHIP BEAD(60ohm, 4516)	HCB4516KF-600T60	1
....5	Q801	HVTKRA102S	T.R , CHIP	KRA102S	1
....5	Q802	HVTKRA102S	T.R , CHIP	KRA102S	1
....5	Q803	CVTKRC103S	T.R , CHIP		1
....5	Q804	CVTKRC103S	T.R , CHIP		1



HDMI PCB ASSY					
Level	Ref. #	Part Number	Description	Drawing No (Value)	Qty
....5	Q806	CVTKRC103S	T.R , CHIP		1
....5	Q807	HVTKRA102S	T.R , CHIP	KRA102S	1
....5	Q808	CVTKRC103S	T.R , CHIP		1
....5	RN100	CRJ064IJ330T	RES , CHIP NETWORK(1/16W, 33ohm, 1005X4	MNR04M0APJ330	1
....5	RN101	CRJ064IJ330T	RES , CHIP NETWORK(1/16W, 33ohm, 1005X4	MNR04M0APJ330	1
....5	RN102	CRJ064IJ330T	RES , CHIP NETWORK(1/16W, 33ohm, 1005X4	MNR04M0APJ330	1
....5	RN103	CRJ064IJ330T	RES , CHIP NETWORK(1/16W, 33ohm, 1005X4	MNR04M0APJ330	1
....5	RN104	CRJ104DJ103T	RES, ARRAY, 10K (1608)	10K(1608)	1
....5	RN105	CRJ104DJ220T	RES,4ARRAY (22 OHM)	22X4/2012	1
....5	RN106	CRJ104DJ220T	RES,4ARRAY (22 OHM)	22X4/2012	1
....5	RN91	CRJ064IJ330T	RES , CHIP NETWORK(1/16W, 33ohm, 1005X4	MNR04M0APJ330	1
....5	RN92	CRJ064IJ330T	RES , CHIP NETWORK(1/16W, 33ohm, 1005X4	MNR04M0APJ330	1
....5	RN93	CRJ064IJ330T	RES , CHIP NETWORK(1/16W, 33ohm, 1005X4	MNR04M0APJ330	1
....5	RN94	CRJ064IJ330T	RES , CHIP NETWORK(1/16W, 33ohm, 1005X4	MNR04M0APJ330	1
....5	RN95	CRJ064IJ330T	RES , CHIP NETWORK(1/16W, 33ohm, 1005X4	MNR04M0APJ330	1
....5	RN96	CRJ064IJ330T	RES , CHIP NETWORK(1/16W, 33ohm, 1005X4	MNR04M0APJ330	1
....5	RN97	CRJ064IJ330T	RES , CHIP NETWORK(1/16W, 33ohm, 1005X4	MNR04M0APJ330	1
....5	RN98	CRJ064IJ330T	RES , CHIP NETWORK(1/16W, 33ohm, 1005X4	MNR04M0APJ330	1
....5	RN99	CRJ064IJ330T	RES , CHIP NETWORK(1/16W, 33ohm, 1005X4	MNR04M0APJ330	1
....5	R801	CRJ10DJ223T	RES , CHIP (22K OHM)	1608 SIZE	1
....5	R802	CRJ10DJ473T	RES , CHIP (47K OHM)	1608 SIZE	1
....5	R803	CRJ10DJ223T	RES , CHIP (22K OHM)	1608 SIZE	1
....5	R804	CRJ10DJ473T	RES , CHIP (47K OHM)	1608 SIZE	1
....5	R806	CRJ10DJ102T	RES , CHIP (1K OHM)	1608 SIZE	1
....5	R807	CRJ10DJ102T	RES , CHIP (1K OHM)	1608 SIZE	1
....5	R808	CRJ10DJ473T	RES , CHIP (47K OHM)	1608 SIZE	1
....5	R809	CRJ10DJ0R0T	RES , CHIP (O OHM)	1608 SIZE	1
....5	R810	CRJ10DJ101T	RES , CHIP (100 OHM)	1608 SIZE	1
....5	R812	CRJ10DJ473T	RES , CHIP (47K OHM)	1608 SIZE	1
....5	R814	CRJ10DJ473T	RES , CHIP (47K OHM)	1608 SIZE	1
....5	R815	CRJ10DJ101T	RES , CHIP (100 OHM)	1608 SIZE	1
....5	R817	CRJ10DJ223T	RES , CHIP (22K OHM)	1608 SIZE	1
....5	R818	CRJ10DJ473T	RES , CHIP (47K OHM)	1608 SIZE	1
....5	R819	CRJ10DJ102T	RES , CHIP (1K OHM)	1608 SIZE	1
....5	R822	CRJ10DJ101T	RES , CHIP (100 OHM)	1608 SIZE	1
....5	R823	CRJ10DF8201T	RES , CHIP (8.2K/1%)		1
....5	R824	CRJ10DF1001T	RES , CHIP 1%	1K/1/10W/F	1
....5	R827	CRJ10DJ473T	RES , CHIP (47K OHM)	1608 SIZE	1
....5	R828	CRJ10DJ0R0T	RES , CHIP (O OHM)	1608 SIZE	1
....5	R829	CRJ10DJ0R0T	RES , CHIP (O OHM)	1608 SIZE	1
....5	R831	CRJ10DJ330T	RES , CHIP (33 OHM)	1608 SIZE	1
....5	R832	CRJ10DJ510T	RES , CHIP (51 OHM)	1608 SIZE	1
....5	R833	CRJ10DJ240T	RES , CHIP (24 OHM)		1
....5	R834	CRJ10DJ510T	RES , CHIP (51 OHM)	1608 SIZE	1
....5	R835	CRJ10DJ240T	RES , CHIP (24 OHM)		1
....5	R836	CRJ10DJ510T	RES , CHIP (51 OHM)	1608 SIZE	1
....5	R837	CRJ10DJ240T	RES , CHIP (24 OHM)		1
....5	R838	CRJ10DJ103T	RES , CHIP (10K OHM)	1608 SIZE	1
....5	R839	CRJ10DJ101T	RES , CHIP (100 OHM)	1608 SIZE	1
....5	R844	CRJ10DJ103T	RES , CHIP (10K OHM)	1608 SIZE	1
....5	R846	CRJ10DJ101T	RES , CHIP (100 OHM)	1608 SIZE	1
....5	R847	CRJ10DJ101T	RES , CHIP (100 OHM)	1608 SIZE	1
....5	R848	CRJ10DJ0R0T	RES , CHIP (O OHM)	1608 SIZE	1
....5	R850	CRJ10DJ101T	RES , CHIP (100 OHM)	1608 SIZE	1
....5	R852	CRJ10DJ101T	RES , CHIP (100 OHM)	1608 SIZE	1
....5	R853	CRJ10DJ103T	RES , CHIP (10K OHM)	1608 SIZE	1
....5	R854	CRJ10DJ472T	RES , CHIP (4.7K OHM)	1608 SIZE	1
....5	R855	CRJ10DJ472T	RES , CHIP (4.7K OHM)	1608 SIZE	1
....5	R856	CRJ10DJ101T	RES , CHIP (100 OHM)	1608 SIZE	1
....5	R858	CRJ10DJ0R0T	RES , CHIP (O OHM)	1608 SIZE	1
....5	R859	CRJ10DJ102T	RES , CHIP (1K OHM)	1608 SIZE	1
....5	R860	CRJ10DJ102T	RES , CHIP (1K OHM)	1608 SIZE	1
....5	R861	CRJ10DJ103T	RES , CHIP (10K OHM)	1608 SIZE	1
....5	R862	CRJ10DJ0R0T	RES , CHIP (O OHM)	1608 SIZE	1
....5	R863	CRJ10DJ103T	RES , CHIP (10K OHM)	1608 SIZE	1
....5	R864	CRJ10DJ103T	RES , CHIP (10K OHM)	1608 SIZE	1
....5	R867	CRJ10DJ0R0T	RES , CHIP (O OHM)	1608 SIZE	1
....5	R868	CRJ10DJ750T	RES , CHIP (75 OHM)	1608 SIZE	1
....5	R869	CRJ10DJ0R0T	RES , CHIP (O OHM)	1608 SIZE	1
....5	R870	CRJ10DJ750T	RES , CHIP (75 OHM)	1608 SIZE	1
....5	R871	CRJ10DJ103T	RES , CHIP (10K OHM)	1608 SIZE	1
....5	R873	CRJ10DJ0R0T	RES , CHIP (O OHM)	1608 SIZE	1
....5	R874	CRJ10DJ0R0T	RES , CHIP (O OHM)	1608 SIZE	1
....5	R875	CRJ10DJ202T	RES , CHIP (2K OHM)		1
....5	R876	CRJ10DJ202T	RES , CHIP (2K OHM)		1
....5	R877	CRJ10DJ103T	RES , CHIP (10K OHM)	1608 SIZE	1
....5	R878	CRJ10DJ103T	RES , CHIP (10K OHM)	1608 SIZE	1
....5	R879	CRJ10DJ103T	RES , CHIP (10K OHM)	1608 SIZE	1
....5	R880	CRJ10DJ104T	RES , CHIP (100K OHM)	1608 SIZE	1

HDMI PCB ASSY					
Level	Ref. #	Part Number	Description	Drawing No (Value)	Qty
...5	R882	CRJ10DJ105T	RES , CHIP (1M OHM)	1608 SIZE	1
...5	R883	CRJ10DJ105T	RES , CHIP (1M OHM)	1608 SIZE	1
...5	X801	COX28636E330S	CRYSTAL (28.63636MHz HC-49/SMD, 33PF)		1
...4	BN54	CJP18GB143ZB	FEMALE HEADER (18P, 2.54mm) , ANGLE TYPE		1
...4	BN82	CWB1D00715058	WIRE ASS'Y (LOCKING TYPE, 2.5MM, 7PIN, 150MM)		1
DC DC PCB ASSY					
Level	Ref. #	Part Number	Description	Drawing No (Value)	Qty
..3		<b>COP12167B</b>	<b>AVR1600 DC DC PCB ASS'Y</b>		<b>1</b>
...5	C50	CCUS1H104KC	CAP , CHIP	0.1UF 50V K	1
...5	C51	CCEC1ACEEX151TY	CAP , ELEC SMD (150uF/10V, 8X10.5, SANYO)	10CE150EX	1
...5	C52	CCEC1CRV471T	CAP , SMD ELECT(MANLEX RV, 16V/470, 10X10)		1
...5	C53	CCUS1H104KC	CAP , CHIP	0.1UF 50V K	1
...5	C54	CCUS1H221JA	CAP , CHIP	220PF 50V J	1
...5	C55	CCUS1H103KC	CAP , CHIP	0.01UF 50V K	1
...5	C56	CCEC1EHVH151TY	CAP , ELEC SMD (150uF/25V, 8X10.5, SANYO)	25HVH150M	1
...5	C57	CCUS1H104KC	CAP , CHIP	0.1UF 50V K	1
...5	C58	CCUS1H103KC	CAP , CHIP	0.01UF 50V K	1
...5	D50	CVDSS34SR	DIODE , SCHOTTKY (40V,3A, DO-214AC) DELTA		1
...5	IC50	CVIS18005QTL	IC , DCDC Converter (3.5A, SOP8) SANKEN		1
...5	L50	CLQ13E470MRZ	COIL , SMD POWER (47UH/3A)	CMI-SSP12L80F-SERIES	1
...5	L51	CLQ13E220MRZ	COIL , SMD POWER (22UH/3A)	CMI-SSP12L80F-SERIES	1
...5	R50	CRJ10DJ223T	RES , CHIP (22K OHM)	1608 SIZE	1
...5	R51	CRJ10DJ623T	RES , CHIP 1608 SIZE (62K OHM)		1
...5	R52	CRJ10DJ512T	RES , CHIP (5.1K OHM)	1608 SIZE	1
...5	R53	CRJ10DJ473T	RES , CHIP (47K OHM)	1608 SIZE	1
...5	R54	CRJ10DJ683T	RES , CHIP (68K OHM)	1608 SIZE	1
...4	BK51	CMD1A569	BRACKET , PCB		1
...4	CN50	CJP08GB142ZB	PIN HEADER (08P, 2.54mm) , ANGLE TYPE		1

# Darlington

# 2SB1559

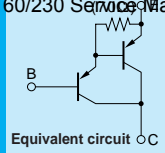

Silicon PNP Epitaxial Planar Transistor (Complement to type 2SD2389)

Application : Audio, Series Regulator and General Purpose

**Absolute maximum ratings** (Ta=25°C)

Symbol	2SB1559	Unit
V <sub>CB0</sub>	-160	V
V <sub>CEO</sub>	-150	V
V <sub>EBO</sub>	-5	V
I <sub>C</sub>	-8	A
I <sub>B</sub>	-1	A
P <sub>C</sub>	80(T <sub>C</sub> =25°C)	W
T <sub>J</sub>	150	°C
T <sub>stg</sub>	-55 to +150	°C

**Electrical Characteristics** (Ta=25°C)

Symbol	Conditions	2SB1559	Unit
I <sub>CB0</sub>	V <sub>CB</sub> =-160V	-100max	μA
I <sub>EBO</sub>	V <sub>EB</sub> =-5V	-100max	μA
V <sub>(BR)CEO</sub>	I <sub>C</sub> =-30mA	-150min	V
h <sub>FE</sub>	V <sub>CE</sub> =-4V, I <sub>C</sub> =-6A	5000min*	
V <sub>CE(sat)</sub>	I <sub>C</sub> =-6A, I <sub>B</sub> =-6mA	-2.5max	V
V <sub>BE(sat)</sub>	I <sub>C</sub> =-6A, I <sub>B</sub> =-6mA	-3.0max	V
f <sub>T</sub>	V <sub>CE</sub> =-12V, I <sub>E</sub> =1A	65typ	MHz
C <sub>OB</sub>	V <sub>CB</sub> =-10V, f=1MHz	160typ	pF

\*h<sub>FE</sub> Rank ○(5000to12000), P(6500to20000), Y(15000to30000)

**Typical Switching Characteristics (Common Emitter)**

V <sub>CC</sub> (V)	R <sub>L</sub> (Ω)	I <sub>C</sub> (A)	V <sub>BB1</sub> (V)	V <sub>BB2</sub> (V)	I <sub>B1</sub> (mA)	I <sub>B2</sub> (mA)	t <sub>on</sub> (μs)	t <sub>stg</sub> (μs)	t <sub>f</sub> (μs)
-60	10	-6	-10	5	-6	6	0.7typ	3.6typ	0.9typ

**External Dimensions MT-100(TO3P)**

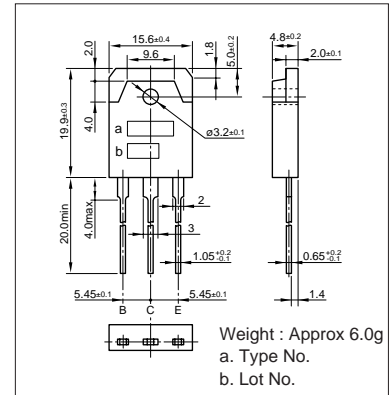

**I<sub>C</sub>-V<sub>CE</sub> Characteristics (Typical)**

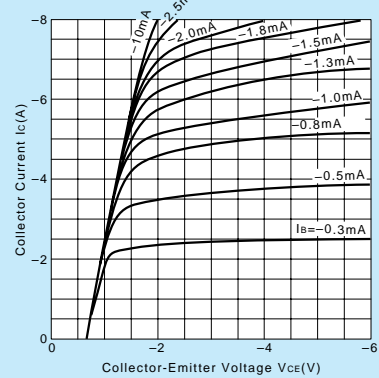

**V<sub>CE(sat)</sub>-I<sub>B</sub> Characteristics (Typical)**

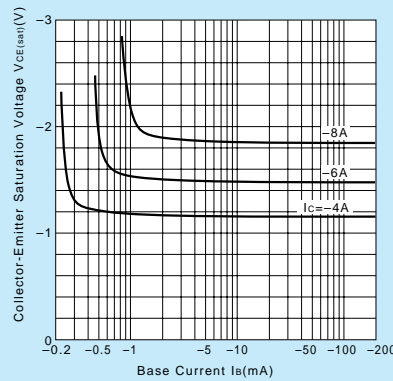

**I<sub>C</sub>-V<sub>BE</sub> Temperature Characteristics (Typical)**

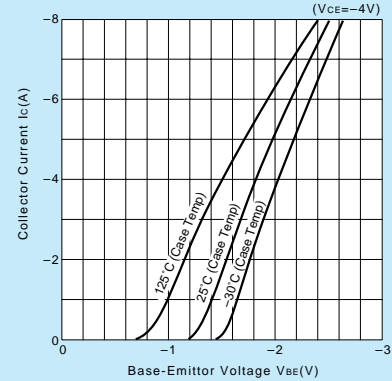

**h<sub>FE</sub>-I<sub>C</sub> Characteristics (Typical)**

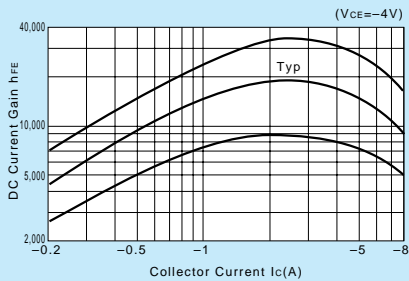

**h<sub>FE</sub>-I<sub>C</sub> Temperature Characteristics (Typical)**

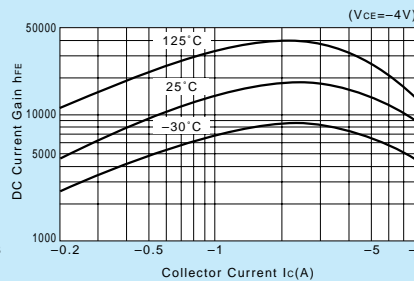

**θ<sub>J-a</sub>-t Characteristics**

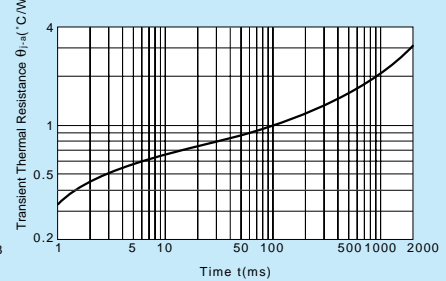

**f<sub>T</sub>-I<sub>E</sub> Characteristics (Typical)**

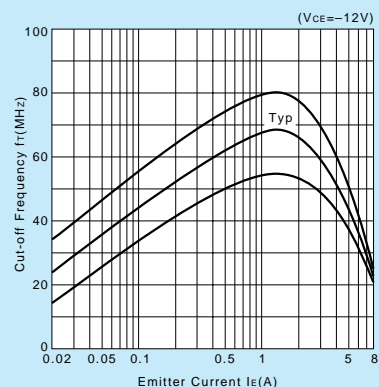

**Safe Operating Area (Single Pulse)**

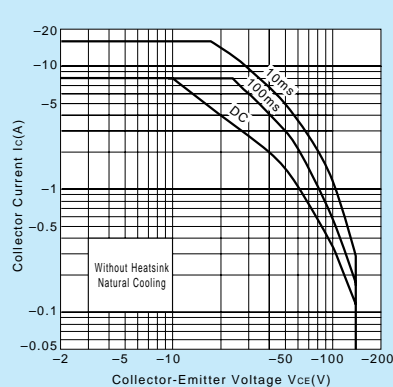

**P<sub>C</sub>-T<sub>a</sub> Derating**

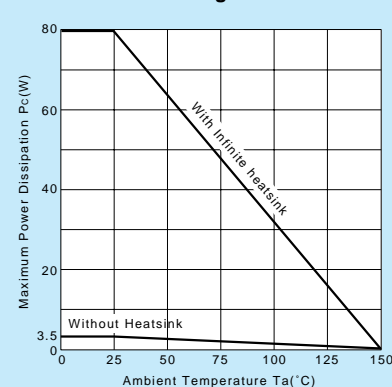

# Darlington 2SD2389

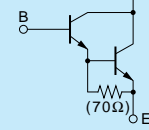

Silicon NPN Triple Diffused Planar Transistor (Complement to type 2SB1559)

Application : Audio, Series Regulator and General Purpose

**Absolute maximum ratings** (Ta=25°C)

Symbol	2SD2389	Unit
V <sub>CB0</sub>	160	V
V <sub>CEO</sub>	150	V
V <sub>EB0</sub>	5	V
I <sub>C</sub>	8	A
I <sub>B</sub>	1	A
P <sub>C</sub>	80(T <sub>C</sub> =25°C)	W
T <sub>J</sub>	150	°C
T <sub>stg</sub>	-55 to +150	°C

**Electrical Characteristics** (Ta=25°C)

Symbol	Conditions	2SD2389	Unit
I <sub>CB0</sub>	V <sub>CB</sub> =160V	100max	μA
I <sub>EB0</sub>	V <sub>EB</sub> =5V	100max	μA
V <sub>(BR)CEO</sub>	I <sub>C</sub> =30mA	150min	V
h <sub>FE</sub>	V <sub>CE</sub> =4V, I <sub>C</sub> =6A	5000min*	
V <sub>CE(sat)</sub>	I <sub>C</sub> =6A, I <sub>B</sub> =6mA	2.5max	V
V <sub>BE(sat)</sub>	I <sub>C</sub> =6A, I <sub>B</sub> =6mA	3.0max	V
f <sub>T</sub>	V <sub>CE</sub> =12V, I <sub>E</sub> =-1A	80typ	MHz
C <sub>OB</sub>	V <sub>CB</sub> =10V, f=1MHz	85typ	pF

\*h<sub>FE</sub> Rank ○(5000to12000), P(6500to20000), Y(15000to30000)

**Typical Switching Characteristics (Common Emitter)**

V <sub>CC</sub> (V)	R <sub>L</sub> (Ω)	I <sub>C</sub> (A)	V <sub>BB1</sub> (V)	V <sub>BB2</sub> (V)	I <sub>B1</sub> (mA)	I <sub>B2</sub> (mA)	t <sub>on</sub> (μs)	t <sub>stg</sub> (μs)	t <sub>f</sub> (μs)
60	10	6	10	-5	6	-6	0.6typ	10.0typ	0.9typ

**External Dimensions MT-100(TO3P)**

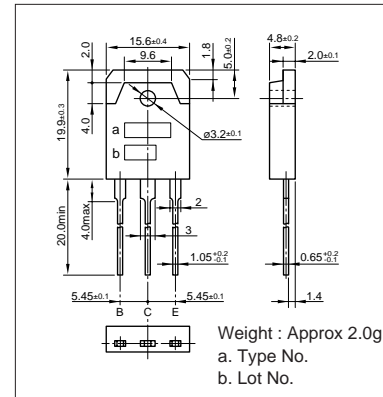

I<sub>C</sub>-V<sub>CE</sub> Characteristics (Typical)

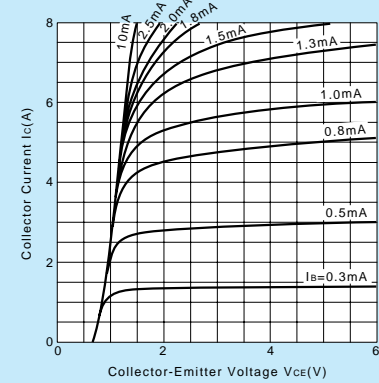

V<sub>CE(sat)</sub>-I<sub>B</sub> Characteristics (Typical)

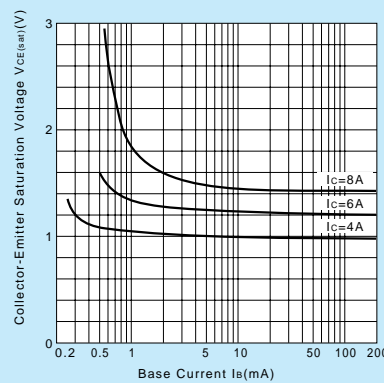

I<sub>C</sub>-V<sub>BE</sub> Temperature Characteristics (Typical)

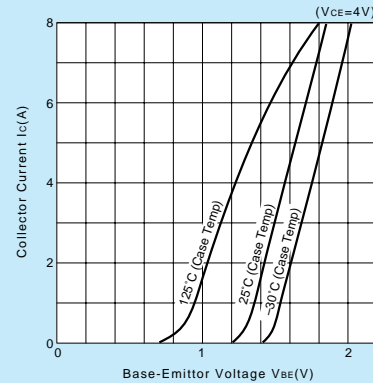

h<sub>FE</sub>-I<sub>C</sub> Characteristics (Typical)

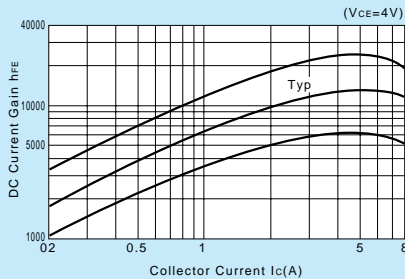

h<sub>FE</sub>-I<sub>C</sub> Temperature Characteristics (Typical)

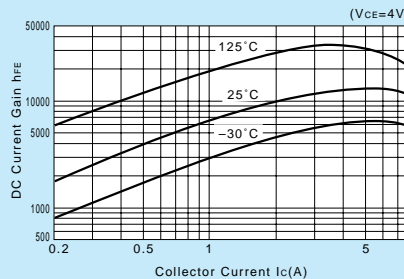

θ<sub>J-a</sub>-t Characteristics

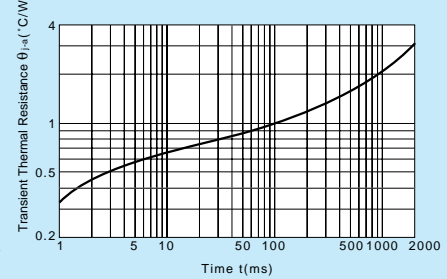

f<sub>T</sub>-I<sub>E</sub> Characteristics (Typical)

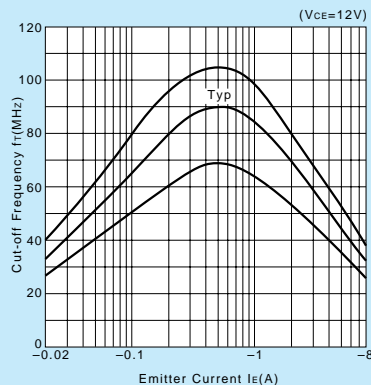

Safe Operating Area (Single Pulse)

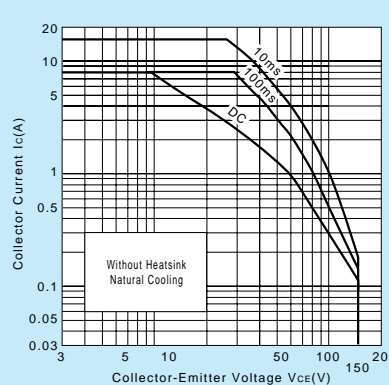

P<sub>C</sub>-T<sub>a</sub> Derating

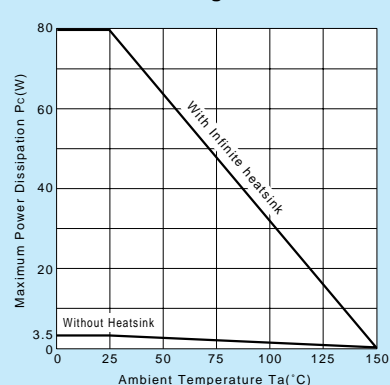

SWITCHING APPLICATION.  
INTERFACE CIRCUIT AND DRIVER CIRCUIT APPLICATION.

**FEATURES**

- With Built-in Bias Resistors.
- Simplify Circuit Design.
- Reduce a Quantity of Parts and Manufacturing Process.

**EQUIVALENT CIRCUIT**

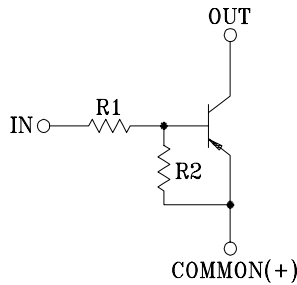

**BIAS RESISTOR VALUES**

TYPE NO.	R1(kΩ)	R2(kΩ)
KRA101S	4.7	4.7
KRA102S	10	10
KRA103S	22	22
KRA104S	47	47
KRA105S	2.2	47
KRA106S	4.7	47

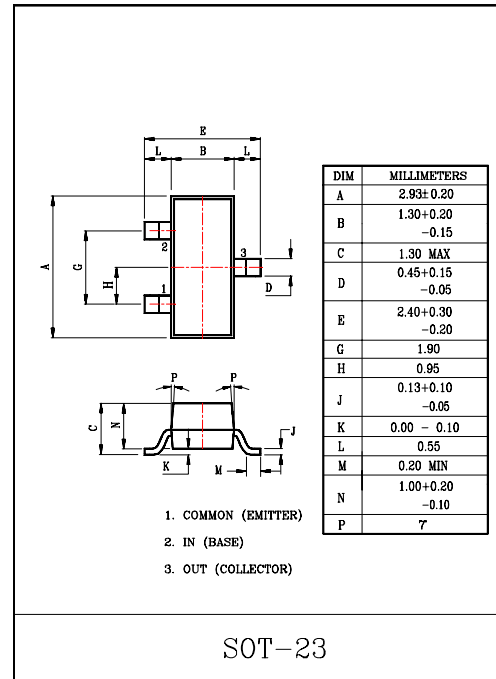

**MAXIMUM RATINGS (Ta=25°C)**

CHARACTERISTIC		SYMBOL	RATING	UNIT
Output Voltage	KRA101S~106S	V <sub>O</sub>	-50	V
Input Voltage	KRA101S	V <sub>I</sub>	-20, 10	V
	KRA102S		-30, 10	
	KRA103S		-40, 10	
	KRA104S		-40, 10	
	KRA105S		-12, 5	
	KRA106S		-20, 5	
Output Current	KRA101S~106S	I <sub>O</sub>	-100	mA
Power Dissipation		P <sub>D</sub>	200	mW
Junction Temperature		T <sub>j</sub>	150	°C
Storage Temperature Range		T <sub>stg</sub>	-55~150	°C

**MARK SPEC**

TYPE	KRA101S	KRA102S	KRA103S	KRA104S	KRA105S	KRA106S
MARK	PA	PB	PC	PD	PE	PF

**Marking**

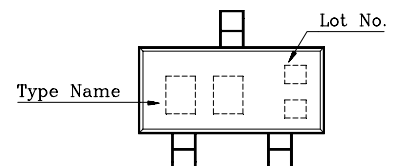

SWITCHING APPLICATION.  
INTERFACE CIRCUIT AND DRIVER  
CIRCUIT APPLICATION.

**FEATURES**

- With Built-in Bias Resistors.
- Simplify Circuit Design.
- Reduce a Quantity of Parts and Manufacturing Process.

**EQUIVALENT CIRCUIT**

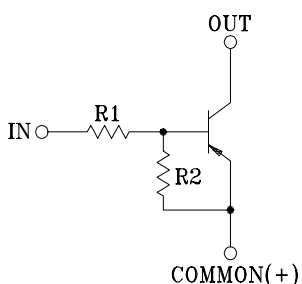

**BIAS RESISTOR VALUES**

TYPE NO.	R1(kΩ)	R2(kΩ)
KRA107M	10	47
KRA108M	22	47
KRA109M	47	22

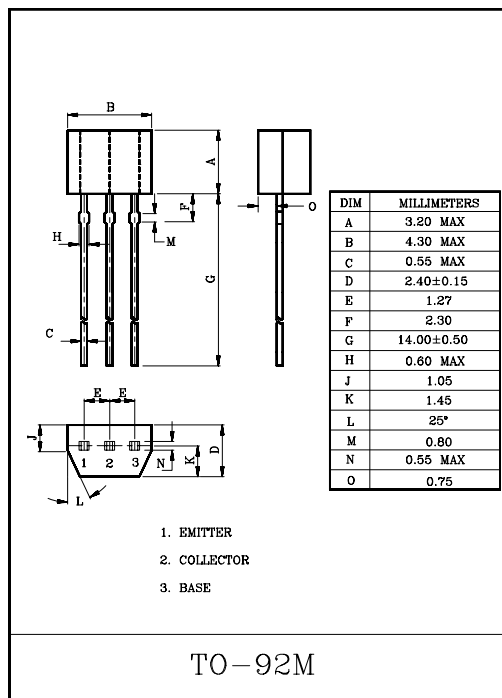

**MAXIMUM RATINGS(Ta=25°C)**

CHARACTERISTIC		SYMBOL	RATING	UNIT
Output Voltage	KRA107M ~109M	V <sub>O</sub>	-50	V
Input Voltage	KRA107M	V <sub>I</sub>	-30, 6	V
	KRA108M		-40, 7	
	KRA109M		-40, 15	
Output Current	KRA107M ~109M	I <sub>O</sub>	-100	mA
Power Dissipation		P <sub>D</sub>	400	mW
Junction Temperature		T <sub>j</sub>	150	°C
Storage Temperature Range		T <sub>stg</sub>	-55~150	°C



SWITCHING APPLICATION.  
INTERFACE CIRCUIT AND DRIVER CIRCUIT APPLICATION.

FEATURES

- With Built-in Bias Resistors
- Simplify Circuit Design
- Reduce a Quantity of Parts and Manufacturing Process

EQUIVALENT CIRCUIT

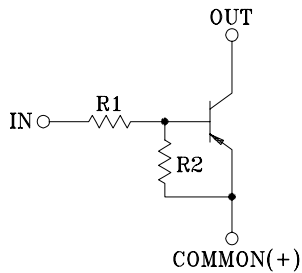

BIAS RESISTOR VALUES

TYPE NO.	R1(kΩ)	R2(kΩ)
KRA107S	10	47
KRA108S	22	47
KRA109S	47	22

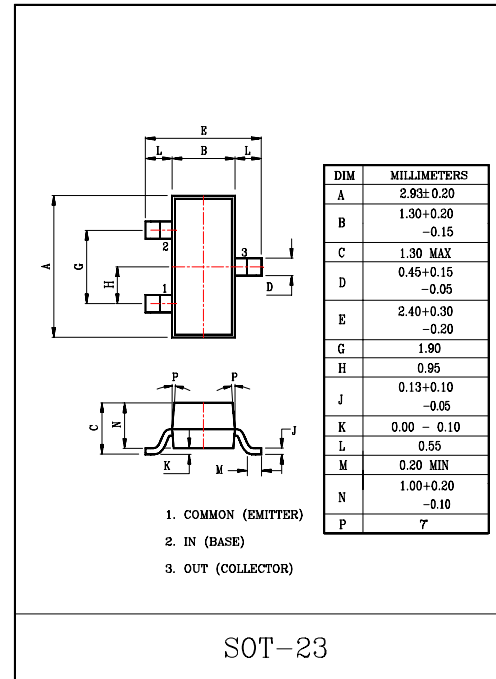

MAXIMUM RATINGS(Ta=25°C)

CHARACTERISTIC		SYMBOL	RATING	UNIT
Output Voltage	KRA107S~109S	V <sub>O</sub>	-50	V
Input Voltage	KRA107S	V <sub>I</sub>	-30, 6	V
	KRA108S		-40, 7	
	KRA109S		-40, 15	
Output Current	KRA107S~109S	I <sub>O</sub>	-100	mA
Power Dissipation		P <sub>D</sub>	200	mW
Junction Temperature		T <sub>j</sub>	150	°C
Storage Temperature Range		T <sub>stg</sub>	-55~150	°C

MARK SPEC

TYPE	KRA107S	KRA108S	KRA109S
MARK	PH	PI	PJ

Marking

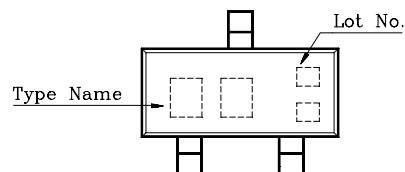

SWITCHING APPLICATION.  
INTERFACE CIRCUIT AND DRIVER CIRCUIT APPLICATION.

**FEATURES**

- With Built-in Bias Resistors.
- Simplify Circuit Design.
- Reduce a Quantity of Parts and Manufacturing Process.

**EQUIVALENT CIRCUIT**

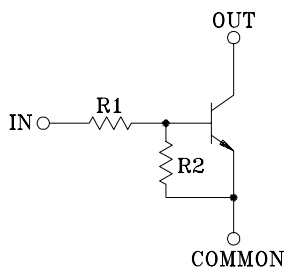

**BIAS RESISTOR VALUES**

TYPE NO.	R1(kΩ)	R2(kΩ)
KRC101S	4.7	4.7
KRC102S	10	10
KRC103S	22	22
KRC104S	47	47
KRC105S	2.2	47
KRC106S	4.7	47

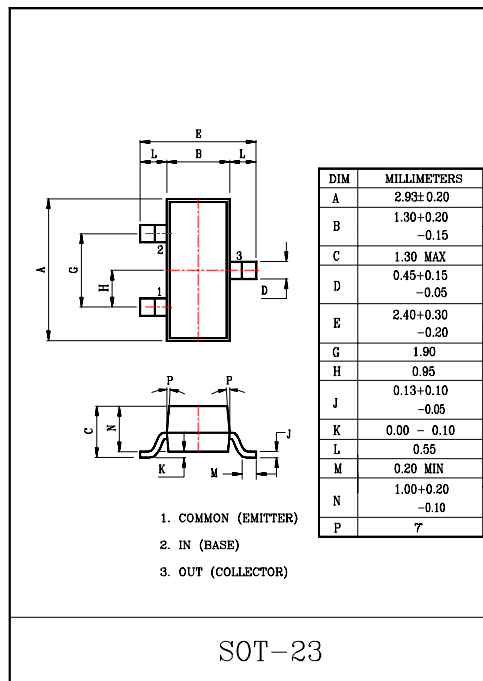

**MAXIMUM RATINGS (Ta=25°C)**

CHARACTERISTIC		SYMBOL	RATING	UNIT
Output Voltage	KRC101S ~ 106S	V <sub>o</sub>	50	V
Input Voltage	KRC101S	V <sub>i</sub>	20, -10	V
	KRC102S		30, -10	
	KRC103S		40, -10	
	KRC104S		40, -10	
	KRC105S		12, -5	
	KRC106S		20, -5	
Output Current	KRC101S ~ 106S	I <sub>o</sub>	100	mA
Power Dissipation		P <sub>d</sub>	200	mW
Junction Temperature		T <sub>j</sub>	150	°C
Storage Temperature Range		T <sub>stg</sub>	-55 ~ 150	°C

**MARK SPEC**

TYPE	KRC101S	KRC102S	KRC103S	KRC104S	KRC105S	KRC106S
MARK	NA	NB	NC	ND	NE	NF

**Marking**

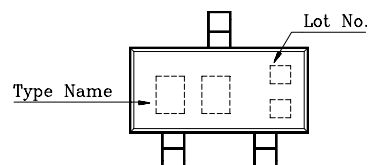

SWITCHING APPLICATION.  
INTERFACE CIRCUIT AND DRIVER CIRCUIT APPLICATION.

**FEATURES**

- With Built-in Bias Resistors.
- Simplify Circuit Design.
- Reduce a Quantity of Parts and Manufacturing Process.

**EQUIVALENT CIRCUIT**

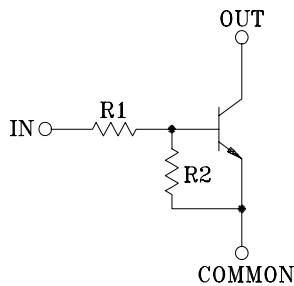

**BIAS RESISTOR VALUES**

TYPE NO.	R1(kΩ)	R2(kΩ)
KRC107M	10	47
KRC108M	22	47
KRC109M	47	22

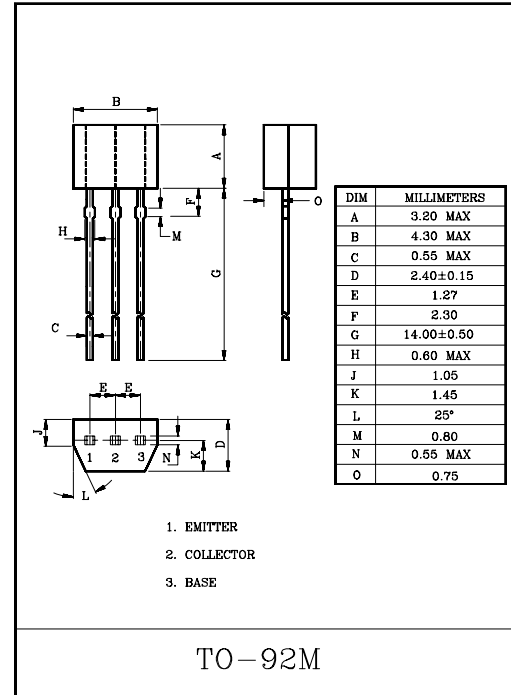

**MAXIMUM RATINGS (Ta=25°C)**

CHARACTERISTIC		SYMBOL	RATING	UNIT
Output Voltage	KRC107M ~109M	V <sub>O</sub>	50	V
Input Voltage	KRC107M	V <sub>I</sub>	30, -6	V
	KRC108M		40, -7	
	KRC109M		40, -15	
Output Current	KRC107M ~109M	I <sub>O</sub>	100	mA
Power Dissipation		P <sub>D</sub>	400	mW
Junction Temperature		T <sub>j</sub>	150	°C
Storage Temperature Range		T <sub>stg</sub>	-55~150	°C

SWITCHING APPLICATION.  
INTERFACE CIRCUIT AND DRIVER CIRCUIT APPLICATION.

**FEATURES**

- With Built-in Bias Resistors.
- Simplify Circuit Design.
- Reduce a Quantity of Parts and Manufacturing Process.

**EQUIVALENT CIRCUIT**

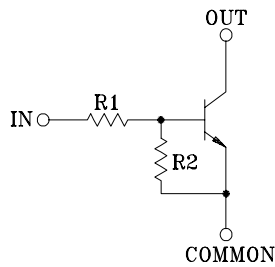

**BIAS RESISTOR VALUES**

TYPE NO.	R1(kΩ)	R2(kΩ)
KRC107S	10	47
KRC108S	22	47
KRC109S	47	22

DIM	MILLIMETERS
A	2.93±0.20
B	1.30+0.20 -0.15
C	1.30 MAX
D	0.45+0.15 -0.05
E	2.40+0.30 -0.20
G	1.90
H	0.95
J	0.13+0.10 -0.05
K	0.00 - 0.10
L	0.55
M	0.20 MIN
N	1.00+0.20 -0.10
P	7

SOT-23

**MAXIMUM RATINGS (Ta=25°C)**

CHARACTERISTIC		SYMBOL	RATING	UNIT
Output Voltage	KRC107S ~109S	V <sub>o</sub>	50	V
Input Voltage	KRC107S	V <sub>i</sub>	30, -6	V
	KRC108S		40, -7	
	KRC109S		40, -15	
Output Current	KRC107S ~109S	I <sub>o</sub>	100	mA
Power Dissipation		P <sub>D</sub>	200	mW
Junction Temperature		T <sub>j</sub>	150	°C
Storage Temperature Range		T <sub>stg</sub>	-55~150	°C

**MARK SPEC**

TYPE	KRC107S	KRC108S	KRC109S
MARK	NH	NI	NJ

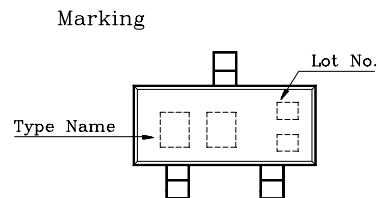

HIGH VOLTAGE APPLICATION.

FEATURE

- Complementary to KTA1023.

MAXIMUM RATINGS(Ta=25°C)

CHARACTERISTIC	SYMBOL	RATING	UNIT
Collector-Base Voltage	V <sub>CBO</sub>	120	V
Collector-Emitter Voltage	V <sub>CEO</sub>	120	V
Emitter-Base Voltage	V <sub>EBO</sub>	5	V
Collector Current	I <sub>C</sub>	800	mA
Emitter Current	I <sub>E</sub>	-800	mA
Collector Power Dissipation	P <sub>C</sub>	1	W
Junction Temperature	T <sub>j</sub>	150	°C
Storage Temperature Range	T <sub>slg</sub>	-55~150	°C

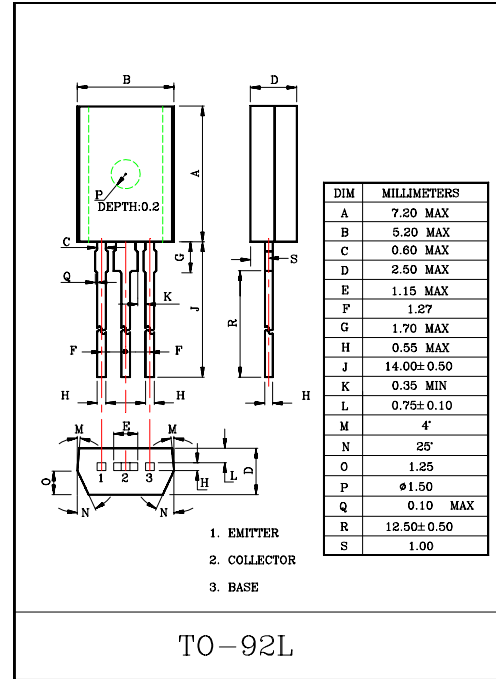

ELECTRICAL CHARACTERISTICS (Ta=25°C)

CHARACTERISTIC	SYMBOL	TEST CONDITION	MIN.	TYP.	MAX.	UNIT
Collector Cut-off Current	I <sub>CBO</sub>	V <sub>CB</sub> =120V, I <sub>E</sub> =0	-	-	100	nA
Emitter Cut-off Current	I <sub>EBO</sub>	V <sub>EB</sub> =5V, I <sub>C</sub> =0	-	-	100	nA
Collector-Emitter Breakdown Voltage	V <sub>(BR)CEO</sub>	I <sub>C</sub> =10mA, I <sub>B</sub> =0	120	-	-	V
Emitter-Base Breakdown Voltage	V <sub>(BR)EBO</sub>	I <sub>E</sub> =1mA, I <sub>C</sub> =0	5.0	-	-	V
DC Current Gain	h <sub>FE</sub> (Note)	V <sub>CE</sub> =5V, I <sub>C</sub> =100mA	80	-	240	
Collector-Emitter Saturation Voltage	V <sub>CE(sat)</sub>	I <sub>C</sub> =500mA, I <sub>B</sub> =50mA	-	-	1.0	V
Base-Emitter Voltage	V <sub>BE</sub>	V <sub>CE</sub> =5V, I <sub>C</sub> =500mA	-	-	1.0	V
Transition Frequency	f <sub>T</sub>	V <sub>CE</sub> =5V, I <sub>C</sub> =100mA	-	120	-	MHz
Collector Output Capacitance	C <sub>ob</sub>	V <sub>CB</sub> =10V, I <sub>E</sub> =0, f=1MHz	-	-	30	pF

Note : h<sub>FE</sub> Classification 0:80~160 , Y:120~240

HIGH VOLTAGE APPLICATION.

FEATURES

- High Voltage :  $V_{CE0} = -150V$ .
- Low Output Capacitance :  $C_{ob} = 5.0pF$ (Max.).
- High Transition Frequency :  $f_T = 120MHz$  (Typ.).
- Complementary to KTC3206.

MAXIMUM RATINGS ( $T_a = 25^\circ C$ )

CHARACTERISTIC	SYMBOL	RATING	UNIT
Collector-Base Voltage	$V_{CBO}$	-150	V
Collector-Emitter Voltage	$V_{CEO}$	-150	V
Emitter-Base Voltage	$V_{EBO}$	-5	V
Collector Current	$I_C$	-50	mA
Emitter Current	$I_E$	50	mA
Collector Power Dissipation	$P_C$	1	W
Junction Temperature	$T_j$	150	$^\circ C$
Storage Temperature Range	$T_{stg}$	-55~150	$^\circ C$

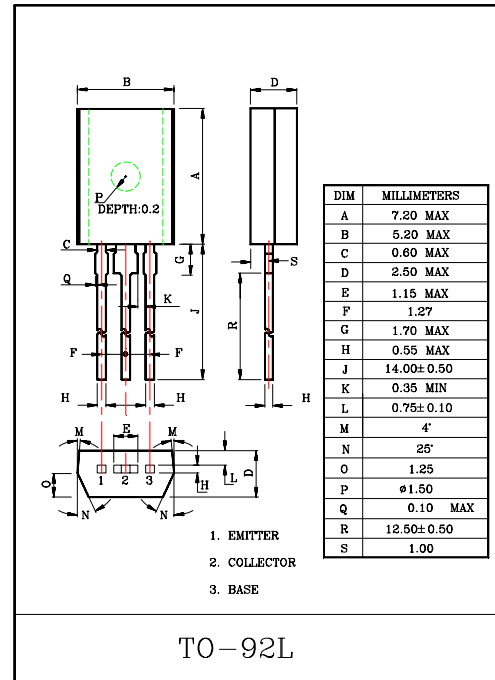

ELECTRICAL CHARACTERISTICS ( $T_a = 25^\circ C$ )

CHARACTERISTIC	SYMBOL	TEST CONDITION	MIN.	TYP.	MAX.	UNIT
Collector Cut-off Current	$I_{CBO}$	$V_{CB} = -150V, I_E = 0$	-	-	-0.1	$\mu A$
Emitter Cut-off Current	$I_{EBO}$	$V_{EB} = -5V, I_C = 0$	-	-	-0.1	$\mu A$
DC Current Gain	$h_{FE}(\text{Note})$	$V_{CE} = -5V, I_C = -10mA$	70	-	240	
Collector-Emitter Saturation Voltage	$V_{CE(sat)}$	$I_C = -10mA, I_B = -1mA$	-	-	-0.8	V
Base-Emitter Voltage	$V_{BE}$	$V_{CE} = -5V, I_C = -30mA$	-	-	-0.9	V
Transition Frequency	$f_T$	$V_{CE} = -30V, I_C = -10mA$	-	120	-	MHz
Collector Output Capacitance	$C_{ob}$	$V_{CB} = -10V, I_E = 0, f = 1MHz$	-	4.0	5.0	pF

Note :  $h_{FE}$  Classification      O:70~140,      Y:120~240



GENERAL PURPOSE APPLICATION  
SWITCHING APPLICATION.

## FEATURES

- Excellent  $h_{FE}$  Linearity  
:  $h_{FE}(0.1mA)/h_{FE}(2mA)=0.95(\text{Typ.})$ .
- Low Noise :  $NF=1dB(\text{Typ.})$ ,  $10dB(\text{Max.})$ .
- Complementary to KTC3199.

MAXIMUM RATINGS ( $T_a=25^\circ\text{C}$ )

CHARACTERISTIC	SYMBOL	RATING	UNIT
Collector-Base Voltage	$V_{CBO}$	-50	V
Collector-Emitter Voltage	$V_{CEO}$	-50	V
Emitter-Base Voltage	$V_{EBO}$	-5	V
Collector Current	$I_C$	-150	mA
Emitter Current	$I_E$	150	mA
Collector Power Dissipation	$P_C$	400	mW
Junction Temperature	$T_j$	150	$^\circ\text{C}$
Storage Temperature Range	$T_{stg}$	-55~150	$^\circ\text{C}$

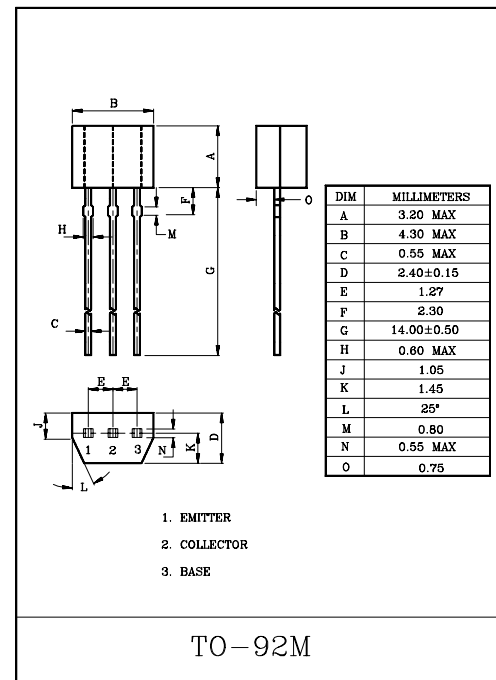
ELECTRICAL CHARACTERISTICS ( $T_a=25^\circ\text{C}$ )

CHARACTERISTIC	SYMBOL	TEST CONDITION	MIN.	TYP.	MAX.	UNIT
Collector Cut-off Current	$I_{CBO}$	$V_{CB}=-50V$ , $I_E=0$	-	-	-0.1	$\mu\text{A}$
Emitter Cut-off Current	$I_{EBO}$	$V_{EB}=-5V$ , $I_C=0$	-	-	-0.1	$\mu\text{A}$
DC Current Gain	$h_{FE}(\text{Note})$	$V_{CE}=-6V$ , $I_C=-2mA$	70	-	400	
Collector-Emitter Saturation Voltage	$V_{CE(sat)}$	$I_C=-100mA$ , $I_B=-10mA$	-	-0.1	-0.3	V
Transition Frequency	$f_T$	$V_{CE}=-10V$ , $I_C=-1mA$	80	-	-	MHz
Collector Output Capacitance	$C_{ob}$	$V_{CB}=-10V$ , $I_E=0$ , $f=1\text{MHz}$	-	4.0	7.0	pF
Noise Figure	NF	$V_{CE}=-6V$ , $I_C=-0.1mA$ , $f=1\text{kHz}$ , $R_g=10k\Omega$	-	1.0	10	dB

Note :  $h_{FE}$  Classification O:70~140 , Y:120~240 , GR:200~400

LOW NOISE AMPLIFIER APPLICATION.  
HIGH VOLTAGE APPLICATION.

**FEATURES**

- Low Noise.
  - : NF=3dB(Typ.), Rg=100Ω, V<sub>CE</sub>=-6V, I<sub>C</sub>=-100μA, f=1kHz
  - : NF=0.5dB(Typ.), Rg=1kΩ, V<sub>CE</sub>=-6V, I<sub>C</sub>=-100μA, f=1kHz.
- High DC Current Gain : h<sub>FE</sub>=200~700.
- High Voltage : V<sub>CBO</sub>=-120V.
- Low Pulse Noise. Low 1/f Noise.

**MAXIMUM RATINGS (Ta=25°C)**

CHARACTERISTIC	SYMBOL	RATING	UNIT
Collector-Base Voltage	V <sub>CBO</sub>	-120	V
Collector-Emitter Voltage	V <sub>CEO</sub>	-120	V
Emitter-Base Voltage	V <sub>EBO</sub>	-5	V
Collector Current	I <sub>C</sub>	-100	mA
Emitter Current	I <sub>E</sub>	100	mA
Collector Power Dissipation	P <sub>C</sub>	625	mW
Junction Temperature	T <sub>j</sub>	150	°C
Storage Temperature Range	T <sub>stg</sub>	-55~150	°C

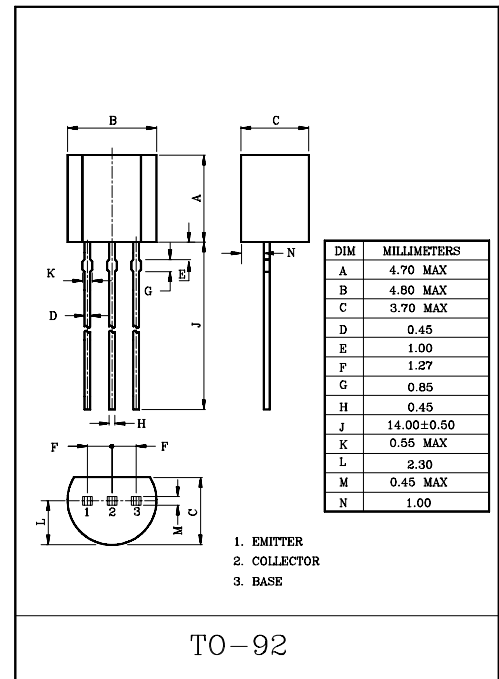

**ELECTRICAL CHARACTERISTICS (Ta=25°C)**

CHARACTERISTIC	SYMBOL	TEST CONDITION	MIN.	TYP.	MAX.	UNIT
Collector Cut-off Current	I <sub>CBO</sub>	V <sub>CB</sub> =-120V, I <sub>E</sub> =0	-	-	-100	nA
Emitter Cut-off Current	I <sub>EBO</sub>	V <sub>EB</sub> =-5V, I <sub>C</sub> =0	-	-	-100	nA
Collector-Emitter Breakdown Voltage	V <sub>CBO</sub>	I <sub>C</sub> =-1mA, I <sub>B</sub> =0	-120	-	-	V
DC Current Gain	h <sub>FE</sub> (Note)	V <sub>CE</sub> =-6V, I <sub>C</sub> =-2mA	200	-	700	
Collector-Emitter Saturation Voltage	V <sub>CE(sat)</sub>	I <sub>C</sub> =-10mA, I <sub>B</sub> =-1mA	-	-	-0.3	V
Base-Emitter Voltage	V <sub>BE</sub>	V <sub>CE</sub> =-6V, I <sub>C</sub> =-2mA	-	-0.65	-	V
Transition Frequency	f <sub>T</sub>	V <sub>CE</sub> =-6V, I <sub>C</sub> =-1mA	-	100	-	MHz
Collector Output Capacitance	C <sub>ob</sub>	V <sub>CB</sub> =-10V, I <sub>E</sub> =0, f=1MHz	-	4.0	-	pF
Noise Figure	NF	V <sub>CE</sub> =-6V, I <sub>C</sub> =-100μA f=10Hz, Rg=10kΩ	-	-	6.0	dB
		V <sub>CE</sub> =-6V, I <sub>C</sub> =-100μA, f=1kHz, Rg=10kΩ	-	-	2.0	
		V <sub>CE</sub> =-6V, I <sub>C</sub> =-100μA f=1kHz, Rg=100Ω	-	3.0	-	

Note : h<sub>FE</sub> Classification GR:200~400, BL:350~700

HIGH CURRENT APPLICATION.

## FEATURES

- High  $h_{FE}$  :  $h_{FE}=100\sim 320$ .
- Complementary to KTC3203.

MAXIMUM RATINGS ( $T_a=25^\circ\text{C}$ )

CHARACTERISTIC	SYMBOL	RATING	UNIT
Collector-Base Voltage	$V_{CBO}$	-35	V
Collector-Emitter Voltage	$V_{CEO}$	-30	V
Emitter-Base Voltage	$V_{EBO}$	-5	V
Collector Current	$I_C$	-800	mA
Emitter Current	$I_E$	800	mA
Collector Power Dissipation	$P_C$	625	mW
Junction Temperature	$T_j$	150	$^\circ\text{C}$
Storage Temperature Range	$T_{stg}$	-55~150	$^\circ\text{C}$

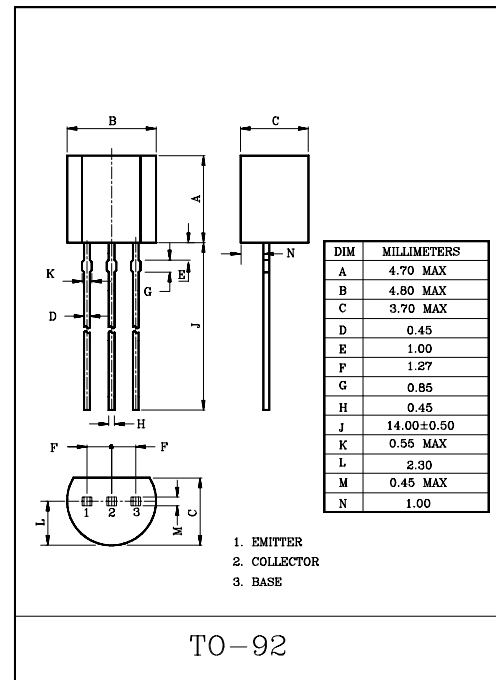
ELECTRICAL CHARACTERISTICS ( $T_a=25^\circ\text{C}$ )

CHARACTERISTIC	SYMBOL	TEST CONDITION	MIN.	TYP.	MAX.	UNIT
Collector Cut-off Current	$I_{CBO}$	$V_{CB}=-35\text{V}$ , $I_E=0$	-	-	-100	nA
Emitter Cut-off Current	$I_{EBO}$	$V_{EB}=-5\text{V}$ , $I_C=0$	-	-	-100	nA
Collector-Emitter Breakdown Voltage	$V_{(BR)CEO}$	$I_C=-10\text{mA}$ , $I_B=0$	-30	-	-	V
DC Current Gain	$h_{FE(1)}$ (Note)	$V_{CE}=-1\text{V}$ , $I_C=-100\text{mA}$	100	-	320	
	$h_{FE(2)}$	$V_{CE}=-1\text{V}$ , $I_C=-700\text{mA}$	35	-	-	
Collector-Emitter Saturation Voltage	$V_{CE(sat)}$	$I_C=-500\text{mA}$ , $I_B=-20\text{mA}$	-	-	-0.7	V
Base-Emitter Voltage	$V_{BE}$	$V_{CE}=-1\text{V}$ , $I_C=-10\text{mA}$	-0.5	-	-0.8	V
Transition Frequency	$f_T$	$V_{CE}=-5\text{V}$ , $I_C=-10\text{mA}$	-	120	-	MHz
Collector Output Capacitance	$C_{ob}$	$V_{CB}=-10\text{V}$ , $f=1\text{MHz}$	-	19	-	pF

Note :  $h_{FE(1)}$  Classification      0:100~200,      Y:160~320

**KEC****SEMICONDUCTOR  
TECHNICAL DATA****KTA1360****TRIPLE DIFFUSED PNP TRANSISTOR**

AUDIO FREQUENCY AMPLIFIER APPLICATION.

## FEATURES

- High Voltage :  $V_{CE0}=-150V$ .
- Low Output Capacitance :  $C_{ob}=5.0pF(Max.)$ .
- High Transition Frequency :  $f_T=120MHz(Typ.)$ .
- Complementary to KTC3423.

MAXIMUM RATING ( $T_a=25^\circ C$ )

CHARACTERISTIC	SYMBOL	RATING	UNIT
Collector-Base Voltage	$V_{CBO}$	-150	V
Collector-Emitter Voltage	$V_{CEO}$	-150	V
Emitter-Base Voltage	$V_{EBO}$	-5	V
Collector Current	$I_C$	-50	mA
Emitter Current	$I_E$	50	mA
Collector Power Dissipation	$P_C$	1.5	W
Junction Temperature	$T_j$	150	$^\circ C$
Storage Temperature Range	$T_{stg}$	-55 ~ 150	$^\circ C$

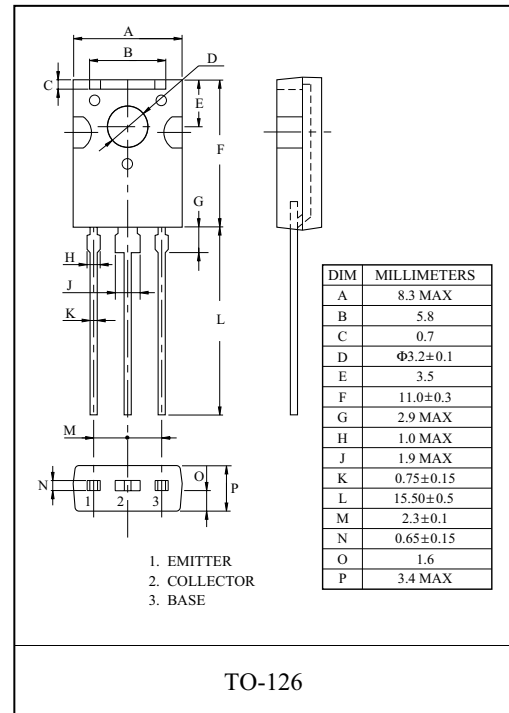
ELECTRICAL CHARACTERISTICS ( $T_a=25^\circ C$ )

CHARACTERISTIC	SYMBOL	TEST CONDITION	MIN.	TYP.	MAX.	UNIT
Collector Cut-off Current	$I_{CBO}$	$V_{CB}=-150V, I_E=0$	-	-	-0.1	$\mu A$
Emitter Cut-off Current	$I_{EBO}$	$V_{EB}=-5V, I_C=0$	-	-	-0.1	$\mu A$
DC Current Gain	$h_{FE}(Note)$	$V_{CE}=-5V, I_C=-10mA$	70	-	240	
Collector-Emitter Saturation Voltage	$V_{CE(sat)}$	$I_C=-10mA, I_B=-1mA$	-	-	-0.8	V
Base-Emitter Voltage	$V_{BE}$	$V_{CE}=-5V, I_C=-30mA$	-	-	-0.9	V
Transition Frequency	$f_T$	$V_{CE}=-30V, I_C=-10mA$	-	120	-	MHz
Collector Output Capacitance	$C_{ob}$	$V_{CB}=-10V, I_E=0, f=1MHz$	-	4.0	5.0	pF

Note :  $h_{FE}$  Classification O:70 ~ 140, Y:120 ~ 240

FOR MUTING AND SWITCHING APPLICATION.

#### FEATURES

- High Emitter-Base Voltage :  $V_{EBO}=25V(\text{Min.})$
- High Reverse  $h_{FE}$   
: Reverse  $h_{FE}=150(\text{Typ.}) (V_{CE}=-2V, I_C=-4mA)$
- Low on Resistance :  $R_{ON}=1 \Omega(\text{Typ.}), (I_B=5mA)$

#### MAXIMUM RATING (Ta=25°C)

CHARACTERISTIC	SYMBOL	RATING	UNIT
Collector-Base Voltage	$V_{CBO}$	50	V
Collector-Emitter Voltage	$V_{CEO}$	20	V
Emitter-Base Voltage	$V_{EBO}$	25	V
Collector Current	$I_C$	300	mA
Base Current	$I_B$	60	mA
Collector Power Dissipation	$P_C^*$	0.9	mW
Junction Temperature	$T_j$	150	°C
Storage Temperature Range	$T_{stg}$	-55 ~ 150	°C

\* Package mounted on a ceramic board (600mm<sup>2</sup> × 0.8mm)

#### EQUIVALENT CIRCUIT (TOP VIEW)

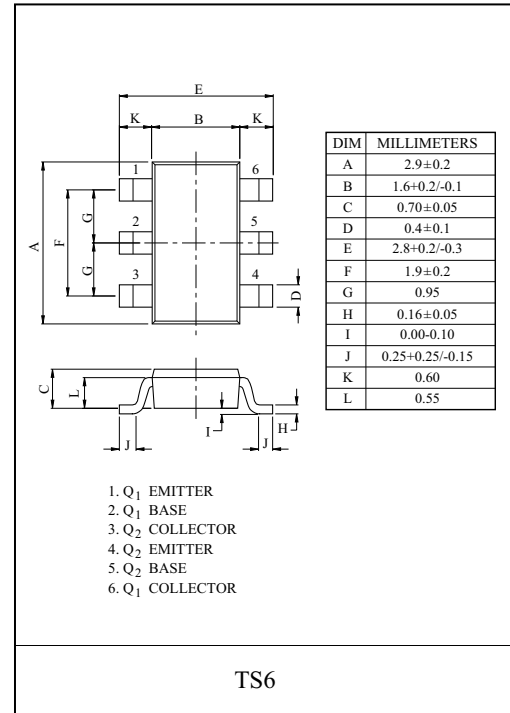
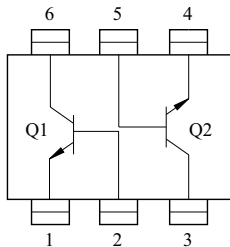

#### Marking

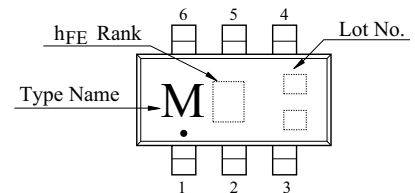

#### ELECTRICAL CHARACTERISTICS (Ta=25°C)

CHARACTERISTIC	SYMBOL	TEST CONDITION	MIN.	TYP.	MAX.	UNIT
Collector Cut-off Current	$I_{CBO}$	$V_{CB}=50V, I_E=0$	-	-	0.1	$\mu A$
Emitter Cut-off Current	$I_{EBO}$	$V_{EB}=25V, I_C=0$	-	-	0.1	$\mu A$
DC Current Gain	$h_{FE}$	$V_{CE}=2V, I_C=4mA$	350	-	1200	
Collector-Emitter Saturation Voltage	$V_{CE(sat)}$	$I_C=30mA, I_B=3mA$	-	0.042	0.3	V
Base-Emitter Voltage	$V_{BE}$	$V_{CE}=2V, I_C=4mA$	-	0.61	-	V
Transition Frequency	$f_T$	$V_{CE}=6V, I_C=4mA$	-	30	-	MHz
Collector Output Capacitance	$C_{ob}$	$V_{CB}=10V, I_E=0, f=1MHz$	-	4.8	7	pF
Switching Time	Turn-on Time	$t_{on}$	-	160	-	nS
	Storage Time	$t_{stg}$	-	500	-	
	Fall Time	$t_f$	-	130	-	

DUTY CYCLE ≤ 2%

$V_{BB} = -3V$

$V_{CC} = 12V$

Note :  $h_{FE}$  Classification B: 350 ~ 1200

FOR MUTING AND SWITCHING APPLICATION.

**FEATURES**

- High Emitter-Base Voltage :  $V_{EBO}=25V(\text{Min.})$
- High Reverse  $h_{FE}$   
: Reverse  $h_{FE}=150(\text{Typ.})$  ( $V_{CE}=-2V, I_C=-2mA$ )
- Low on Resistance :  $R_{ON}=1\Omega(\text{Typ.})$ , ( $I_B=5mA$ )

**MAXIMUM RATINGS ( $T_a=25^\circ C$ )**

CHARACTERISTIC	SYMBOL	RATING	UNIT
Collector-Base Voltage	$V_{CBO}$	50	V
Collector-Emitter Voltage	$V_{CEO}$	20	V
Emitter-Base Voltage	$V_{EBO}$	25	V
Collector Current	$I_C$	300	mA
Base Current	$I_B$	60	mA
Collector Power Dissipation	$P_C$	400	mW
Junction Temperature	$T_j$	125	$^\circ C$
Storage Temperature Range	$T_{stg}$	-55 ~ 125	$^\circ C$

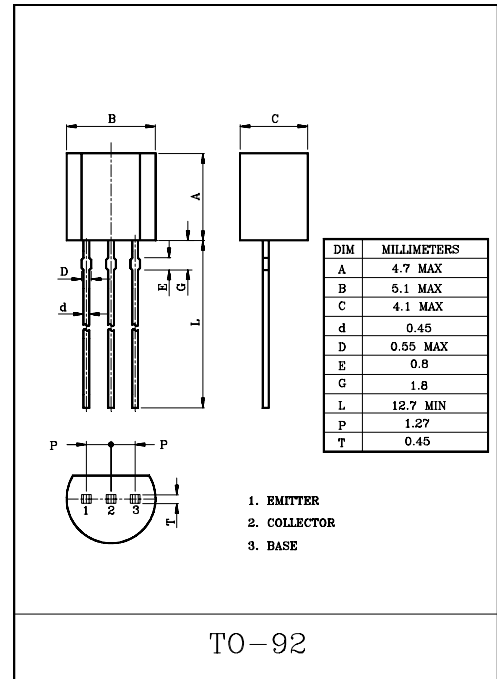

**ELECTRICAL CHARACTERISTICS ( $T_a=25^\circ C$ )**

CHARACTERISTIC	SYMBOL	TEST CONDITION	MIN.	TYP.	MAX.	UNIT
Collector Cut-off Current	$I_{CBO}$	$V_{CB}=50V, I_E=0$	-	-	0.1	$\mu A$
Emitter Cut-off Current	$I_{EBO}$	$V_{EB}=25V, I_C=0$	-	-	0.1	$\mu A$
DC Current Gain (Note)	$h_{FE}$	$V_{CE}=2V, I_C=4mA$	200	-	1200	
Collector-Emitter Saturation Voltage	$V_{CE(sat)}$	$I_C=30mA, I_B=3mA$	-	0.042	0.3	V
Base-Emitter Voltage	$V_{BE}$	$V_{CE}=2V, I_C=4mA$	-	0.61	-	V
Transition Frequency	$f_T$	$V_{CE}=6V, I_C=4mA$	-	30	-	MHz
Collector Output Capacitance	$C_{ob}$	$V_{CB}=10V, I_E=0, f=1MHz$	-	4.8	7	pF
Switching Time	Turn-on Time	$t_{ON}$	-	160	-	nS
	Storage Time	$t_{stg}$	-	500	-	
	Fall Time	$t_f$	-	130	-	

DUTY CYCLE ≤ 2%

Note :  $h_{FE}$  Classification A: 200 ~ 700 , B: 350 ~ 1200



GENERAL PURPOSE APPLICATION.  
 SWITCHING APPLICATION.

### FEATURES

- Excellent  $h_{FE}$  Linearity  
 :  $h_{FE(2)}=100(\text{Typ.})$  at  $V_{CE}=6V, I_C=150\text{mA}$ .  
 :  $h_{FE(I_C=0.1\text{mA})}/h_{FE(I_C=2\text{mA})}=0.95(\text{Typ.})$
- Low Noise :  $NF=1\text{dB}(\text{Typ.})$  at  $f=1\text{kHz}$ .
- Complementary to KTA1266 (O,Y,GR class).

### MAXIMUM RATINGS ( $T_a=25^\circ\text{C}$ )

CHARACTERISTIC	SYMBOL	RATING	UNIT
Collector-Base Voltage	$V_{CBO}$	60	V
Collector-Emitter Voltage	$V_{CEO}$	50	V
Emitter-Base Voltage	$V_{EBO}$	5	V
Collector Current	$I_C$	150	mA
Base Current	$I_B$	50	mA
Collector Power Dissipation	$P_C$	625	mW
Junction Temperature	$T_j$	150	$^\circ\text{C}$
Storage Temperature Range	$T_{\text{sig}}$	-55~150	$^\circ\text{C}$

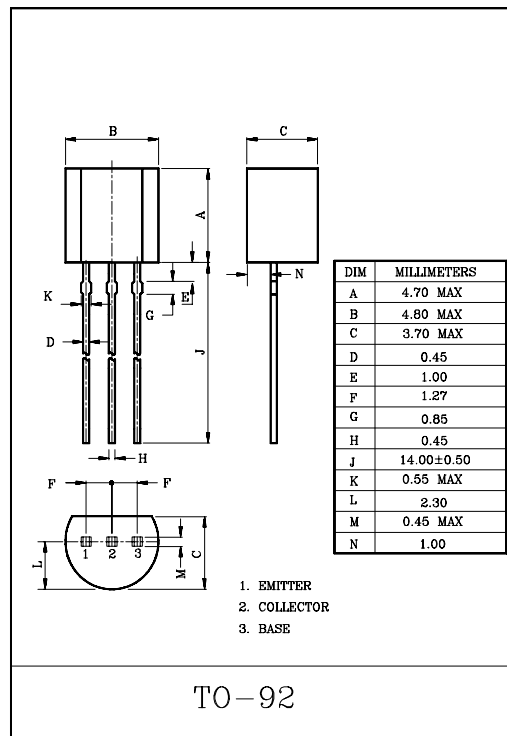

### ELECTRICAL CHARACTERISTICS ( $T_a=25^\circ\text{C}$ )

CHARACTERISTIC	SYMBOL	TEST CONDITION	MIN.	TYP.	MAX.	UNIT
Collector Cut-off Current	$I_{CBO}$	$V_{CB}=60V, I_E=0$	-	-	0.1	$\mu\text{A}$
Emitter Cut-off Current	$I_{EBO}$	$V_{EB}=5V, I_C=0$	-	-	0.1	$\mu\text{A}$
DC Current Gain	$h_{FE(1)}$ (Note)	$V_{CE}=6V, I_C=2\text{mA}$	70	-	700	
	$h_{FE(2)}$	$V_{CE}=6V, I_C=150\text{mA}$	25	100	-	
Collector-Emitter Saturation Voltage	$V_{CE(sat)}$	$I_C=100\text{mA}, I_B=10\text{mA}$	-	0.1	0.25	V
Base-Emitter Saturation Voltage	$V_{BE(sat)}$	$I_C=100\text{mA}, I_B=10\text{mA}$	-	-	1.0	V
Transition Frequency	$f_T$	$V_{CE}=10V, I_E=-1\text{mA}$	80	-	-	MHz
Collector Output Capacitance	$C_{ob}$	$V_{CB}=10V, I_E=0, f=1\text{MHz}$	-	2.0	3.5	pF
Base Intrinsic Resistance	$r_{bb'}$	$V_{CB}=10V, I_C=-1\text{mA}, f=30\text{MHz}$	-	50	-	$\Omega$
Noise Figure	NF	$V_{CE}=6V, I_C=0.1\text{mA}, R_g=10k\Omega, f=1\text{kHz}$	-	1.0	10	dB

Note :  $h_{FE}$  Classification O:70~140, Y:120~240, GR:200~400, BL:300~700

GENERAL PURPOSE APPLICATION.  
SWITCHING APPLICATION.

**FEATURES**

- High DC Current Gain :  $h_{FE}=70\sim 700$ .
- Excellent  $h_{FE}$  Linearity  
:  $h_{FE}(0.1mA)/h_{FE}(2mA)=0.95$ (Typ.).
- Low Noise : NF=1dB(Typ.), 10dB(Max.).
- Complementary to KTA1267.

**MAXIMUM RATINGS (Ta=25°C)**

CHARACTERISTIC	SYMBOL	RATING	UNIT
Collector-Base Voltage	$V_{CBO}$	50	V
Collector-Emitter Voltage	$V_{CEO}$	50	V
Emitter-Base Voltage	$V_{EBO}$	5	V
Collector Current	$I_C$	150	mA
Emitter Current	$I_E$	-150	mA
Collector Power Dissipation	$P_C$	400	mW
Junction Temperature	$T_j$	150	°C
Storage Temperature Range	$T_{stg}$	-55~150	°C

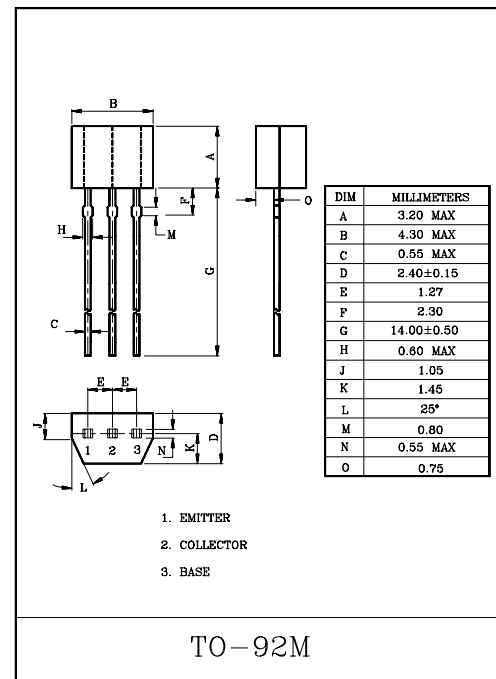
**ELECTRICAL CHARACTERISTICS (Ta=25°C)**

CHARACTERISTIC	SYMBOL	TEST CONDITION	MIN.	TYP.	MAX.	UNIT
Collector Cut-off Current	$I_{CBO}$	$V_{CB}=50V, I_E=0$	-	-	0.1	$\mu A$
Emitter Cut-off Current	$I_{EBO}$	$V_{EB}=5V, I_C=0$	-	-	0.1	$\mu A$
DC Current Gain	$h_{FE}$ (Note)	$V_{CE}=6V, I_C=2mA$	70	-	700	
Collector-Emitter Saturation Voltage	$V_{CE(sat)}$	$I_C=100mA, I_B=10mA$	-	0.1	0.25	V
Transition Frequency	$f_T$	$V_{CE}=10V, I_C=1mA$	80	-	-	MHz
Collector Output Capacitance	$C_{ob}$	$V_{CB}=10V, I_E=0, f=1MHz$	-	2.0	3.5	pF
Noise Figure	NF	$V_{CE}=6V, I_C=0.1mA$ $R_g=10k\Omega, f=1kHz$	-	1.0	10	dB

Note)  $h_{FE}$  Classification O : 70~140, Y : 120~240, GR : 200~400, BL : 300~700

AUDIO FREQUENCY AMPLIFIER APPLICATION.

FEATURES

- High Breakdown Voltage :  $V_{CE0}=150V(\text{Min.})$ .
- Low Output Capacitance :  $C_{ob}=5.0pF(\text{Max.})$ .
- High Transition Frequency :  $f_T=120MHz(\text{Typ.})$ .
- Complementary to KTA1360.

MAXIMUM RATING ( $T_a=25^\circ C$ )

CHARACTERISTIC	SYMBOL	RATING	UNIT
Collector-Base Voltage	$V_{CBO}$	150	V
Collector-Emitter Voltage	$V_{CEO}$	150	V
Emitter-Base Voltage	$V_{EBO}$	5	V
Collector Current	$I_C$	50	mA
Emitter Current	$I_B$	5	mA
Collector Power Dissipation	$P_C$	$T_a=25^\circ C$	1.5
		$T_c=25^\circ C$	5
Junction Temperature	$T_j$	150	$^\circ C$
Storage Temperature Range	$T_{stg}$	-55 ~ 150	$^\circ C$

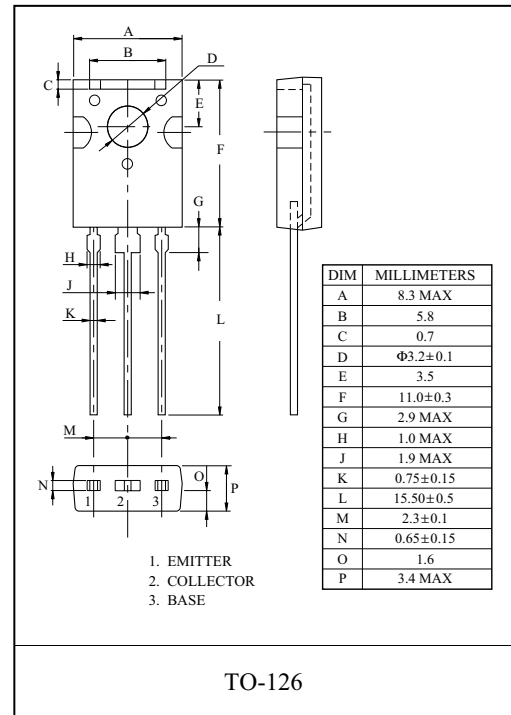

ELECTRICAL CHARACTERISTICS ( $T_a=25^\circ C$ )

CHARACTERISTIC	SYMBOL	TEST CONDITION	MIN.	TYP.	MAX.	UNIT
Collector Cut-off Current	$I_{CBO}$	$V_{CB}=150V, I_E=0$	-	-	0.1	$\mu A$
Emitter Cut-off Current	$I_{EBO}$	$V_{EB}=5V, I_C=0$	-	-	0.1	$\mu A$
DC Current Gain	$h_{FE}(\text{Note})$	$V_{CE}=5V, I_C=10mA$	70	-	240	
Collector-Emitter Saturation Voltage	$V_{CE(sat)}$	$I_C=10mA, I_B=1mA$	-	-	0.5	V
Base-Emitter Saturation Voltage	$V_{BE(sat)}$	$I_C=10mA, I_B=1mA$	-	-	1.0	V
Transition Frequency	$f_T$	$V_{CE}=30V, I_C=10mA$	-	120	-	MHz
Collector Output Capacitance	$C_{ob}$	$V_{CB}=10V, I_E=0, f=1MHz$	-	3.5	5.0	pF

Note :  $h_{FE}$  Classification O:70 ~ 140, Y:120 ~ 240

LOW FREQUENCY POWER AMP,  
MEDIUM SPEED SWITCHING APPLICATIONS

**FEATURES**

- High breakdown voltage  $V_{CEO}$  120V, high current 1A.
- Low saturation voltage and good linearity of  $h_{FE}$ .

**MAXIMUM RATINGS ( $T_a=25^\circ\text{C}$ )**

CHARACTERISTIC		SYMBOL	RATING	UNIT
Collector-Base Voltage		$V_{CBO}$	120	V
Collector-Emitter Voltage		$V_{CEO}$	120	V
Emitter-Base Voltage		$V_{EBO}$	5	V
Collector Current		$I_C$	1	A
		$I_{CP}$	2	
Collector Power Dissipation	$T_a=25^\circ\text{C}$	$P_C$	1.5	W
	$T_c=25^\circ\text{C}$		8	
Junction Temperature		$T_j$	150	$^\circ\text{C}$
Storage Temperature Range		$T_{stg}$	-55~150	$^\circ\text{C}$

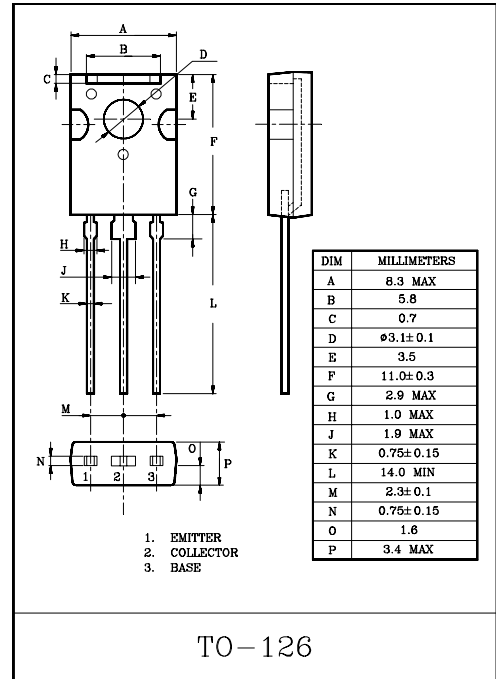

**ELECTRICAL CHARACTERISTICS ( $T_a=25^\circ\text{C}$ )**

CHARACTERISTIC		SYMBOL	TEST CONDITION	MIN.	TYP.	MAX.	UNIT
Collector Cut of Current		$I_{CBO}$	$V_{CB}=50\text{V}, I_E=0$	-	-	1	$\mu\text{A}$
Emitter Cut of Current		$I_{EBO}$	$V_{EB}=4\text{V}, I_C=0$	-	-	1	$\mu\text{A}$
Collector-Base Breakdown Voltage		$V_{(BR)CBO}$	$I_C=10\mu\text{A}$	120	-	-	V
Collector-Emitter Breakdown Voltage		$V_{(BR)CEO}$	$I_C=1\text{mA}$	120	-	-	V
Emitter-Base Breakdown Voltage		$V_{(BR)EBO}$	$I_E=10\mu\text{A}$	5	-	-	V
DC Current Gain	$h_{FE(1)}$ Note		$V_{CE}=5\text{V}, I_C=50\text{mA}$	100	-	320	
	$h_{FE(2)}$		$V_{CE}=5\text{V}, I_C=500\text{mA}$	20	-	-	
Gain Bandwidth Product		$f_T$	$V_{CE}=10\text{V}, I_C=50\text{mA}$	-	130	-	MHz
Output Capacitance		$C_{ob}$	$V_{CB}=10\text{V}, f=1\text{MHz}$	-	20	-	pF
Collector-Emitter Saturation Voltage		$V_{CE(sat)}$	$I_C=500\text{mA}, I_B=50\text{mA}$	-	0.15	0.4	V
Base-Emitter Saturation Voltage		$V_{BE(sat)}$	$I_C=500\text{mA}, I_B=50\text{mA}$	-	0.85	1.2	V
Switching Time	Turn-on Time	$t_{on}$		-	100	-	nS
	Turn-off Time	$t_{off}$		-	500	-	
	Storage Time	$t_{stg}$		-	700	-	

(Note) :  $h_{FE(1)}$  Classification Y:100~200, GR:160~320



# 74ACT04

## HEX INVERTER

- HIGH SPEED:  $t_{PD} = 5.0ns$  (TYP.) at  $V_{CC} = 5V$
- LOW POWER DISSIPATION:  
 $I_{CC} = 2\mu A$ (MAX.) at  $T_A=25^\circ C$
- COMPATIBLE WITH TTL OUTPUTS  
 $V_{IH} = 2V$  (MIN.),  $V_{IL} = 0.8V$  (MAX.)
- $50\Omega$  TRANSMISSION LINE DRIVING CAPABILITY
- SYMMETRICAL OUTPUT IMPEDANCE:  
 $|I_{OH}| = I_{OL} = 24mA$  (MIN)
- BALANCED PROPAGATION DELAYS:  
 $t_{PLH} \cong t_{PHL}$
- OPERATING VOLTAGE RANGE:  
 $V_{CC}$  (OPR) = 4.5V to 5.5V
- PIN AND FUNCTION COMPATIBLE WITH 74 SERIES 04
- IMPROVED LATCH-UP IMMUNITY

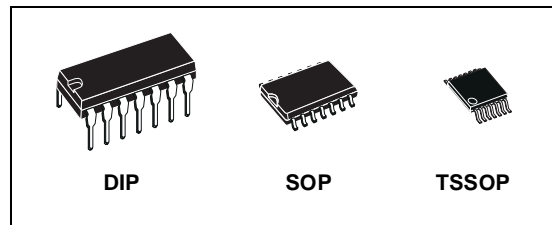

### ORDER CODES

PACKAGE	TUBE	T & R
DIP	74ACT04B	
SOP	74ACT04M	74ACT04MTR
TSSOP		74ACT04TTR

### DESCRIPTION

The 74ACT04 is an advanced high-speed CMOS HEX INVERTER fabricated with sub-micron silicon gate and double-layer metal wiring C<sup>2</sup>MOS technology.

The internal circuit is composed of 3 stages including buffer output, which enables high noise immunity and stable output.

The device is designed to interface directly High Speed CMOS systems with TTL, NMOS and CMOS output voltage levels.

All inputs and outputs are equipped with protection circuits against static discharge, giving them 2KV ESD immunity and transient excess voltage.

### PIN CONNECTION AND IEC LOGIC SYMBOLS

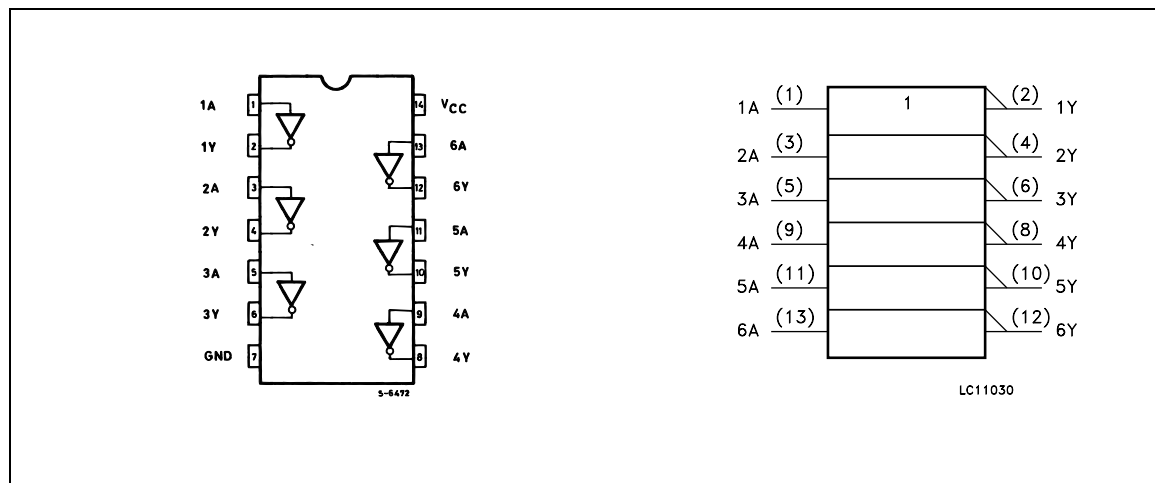

## 74ACT04

### INPUT AND OUTPUT EQUIVALENT CIRCUIT

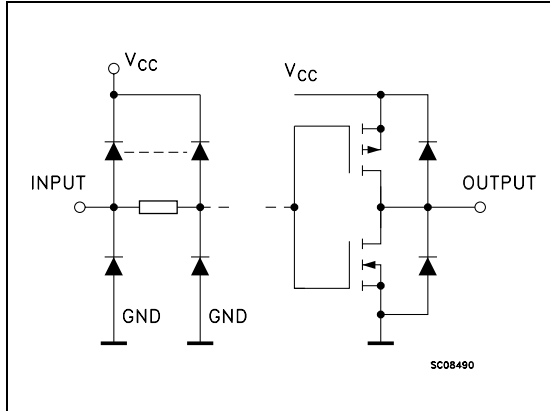

### PIN DESCRIPTION

PIN No	SYMBOL	NAME AND FUNCTION
1, 3, 5, 9, 11, 13	1A to 6A	Data Inputs
2, 4, 6, 8, 10, 12	1Y to 6Y	Data Outputs
7	GND	Ground (0V)
14	V <sub>CC</sub>	Positive Supply Voltage

### TRUTH TABLE

A	Y
L	H
H	L

### ABSOLUTE MAXIMUM RATINGS

Symbol	Parameter	Value	Unit
V <sub>CC</sub>	Supply Voltage	-0.5 to +7	V
V <sub>I</sub>	DC Input Voltage	-0.5 to V <sub>CC</sub> + 0.5	V
V <sub>O</sub>	DC Output Voltage	-0.5 to V <sub>CC</sub> + 0.5	V
I <sub>IK</sub>	DC Input Diode Current	± 20	mA
I <sub>OK</sub>	DC Output Diode Current	± 20	mA
I <sub>O</sub>	DC Output Current	± 50	mA
I <sub>CC</sub> or I <sub>GND</sub>	DC V <sub>CC</sub> or Ground Current	± 200	mA
T <sub>stg</sub>	Storage Temperature	-65 to +150	°C
T <sub>L</sub>	Lead Temperature (10 sec)	300	°C

Absolute Maximum Ratings are those values beyond which damage to the device may occur. Functional operation under these conditions is not implied.

### RECOMMENDED OPERATING CONDITIONS

Symbol	Parameter	Value	Unit
V <sub>CC</sub>	Supply Voltage	4.5 to 5.5	V
V <sub>I</sub>	Input Voltage	0 to V <sub>CC</sub>	V
V <sub>O</sub>	Output Voltage	0 to V <sub>CC</sub>	V
T <sub>op</sub>	Operating Temperature	-55 to 125	°C
dt/dv	Input Rise and Fall Time V <sub>CC</sub> = 4.5 to 5.5V (note 1)	8	ns/V

1) V<sub>IN</sub> from 0.8V to 2.0V



TOSHIBA CMOS DIGITAL INTEGRATED CIRCUIT SILICON MONOLITHIC

**TC74HCU04AP, TC74HCU04AF, TC74HCU04AFN**

**HEX INVERTER**

(Note) The JEDEC SOP (FN) is not available in Japan.

The TC74HCU04A is a high speed CMOS INVERTER fabricated with silicon gate C<sup>2</sup>MOS technology.

It achieves the high speed operation similar to equivalent LSTTL while maintaining the CMOS low power dissipation. Since the internal circuit is composed of a single stage inverter, it can be used in analog applications such as crystal oscillators.

All inputs are equipped with protection circuits against static discharge or transient excess voltage.

**FEATURES :**

- High Speed..... $t_{pd} = 4ns(\text{typ.})$  at  $V_{CC} = 5V$
- Low Power Dissipation..... $I_{CC} = 1\mu A(\text{Max.})$  at  $T_a = 25^\circ C$
- High Noise Immunity..... $V_{NIH} = V_{NIH} = 10\%V_{CC}$  (Min.)
- Output Drive Capability..... 10 LSTTL Loads
- Symmetrical Output Impedance... $|I_{OH}| = I_{OL} = 4mA(\text{Min.})$
- Balanced Propagation Delays..... $t_{pLH} \approx t_{pHL}$
- Wide Operating Voltage Range... $V_{CC}(\text{opr.}) = 2V \sim 6V$
- Pin and Function Compatible with 74LS04

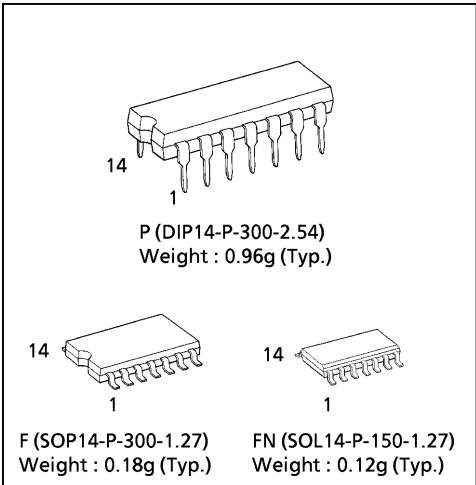

**PIN ASSIGNMENT**

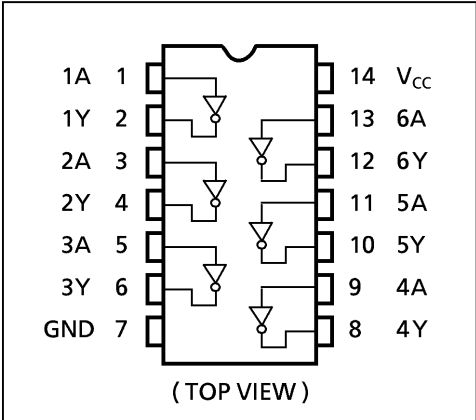

**IEC LOGIC SYMBOL**

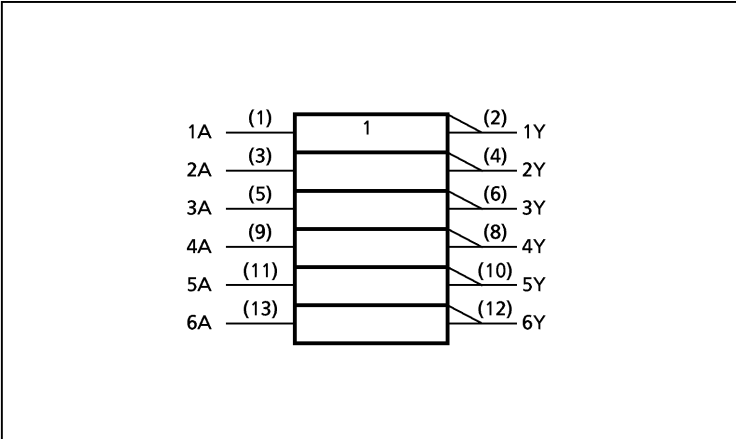

**TRUTH TABLE**

A	Y
L	H
H	L

961001EBA2

● TOSHIBA is continually working to improve the quality and the reliability of its products. Nevertheless, semiconductor devices in general can malfunction or fail due to their inherent electrical sensitivity and vulnerability to physical stress. It is the responsibility of the buyer, when utilizing TOSHIBA products, to observe standards of safety, and to avoid situations in which a malfunction or failure of a TOSHIBA product could cause loss of human life, bodily injury or damage to property. In developing your designs, please ensure that TOSHIBA products are used within specified operating ranges as set forth in the most recent products specifications. Also, please keep in mind the precautions and conditions set forth in the TOSHIBA Semiconductor Reliability Handbook.

**TOSHIBA****TC74HCU04AP/AF/AFN****ABSOLUTE MAXIMUM RATINGS**

PARAMETER	SYMBOL	VALUE	UNIT
Supply Voltage Range	$V_{CC}$	-0.5~7	V
DC Input Voltage	$V_{IN}$	-0.5~ $V_{CC}+0.5$	V
DC Output Voltage	$V_{OUT}$	-0.5~ $V_{CC}+0.5$	V
Input Diode Current	$I_{IK}$	±20	mA
Output Diode Current	$I_{OK}$	±20	mA
DC Output Current	$I_{OUT}$	±25	mA
DC $V_{CC}$ / Ground Current	$I_{CC}$	±50	mA
Power Dissipation	$P_D$	500 (DIP)* / 180 (SOP)	mW
Storage Temperature	$T_{stg}$	-65~150	°C

\*500mW in the range of  $T_a = -40^{\circ}\text{C} \sim 65^{\circ}\text{C}$ . From  $T_a = 65^{\circ}\text{C}$  to  $85^{\circ}\text{C}$  a derating factor of  $-10\text{mW}/^{\circ}\text{C}$  shall be applied until 300mW.

**RECOMMENDED OPERATING CONDITIONS**

PARAMETER	SYMBOL	VALUE	UNIT
Supply Voltage	$V_{CC}$	2~6	V
Input Voltage	$V_{IN}$	0~ $V_{CC}$	V
Output Voltage	$V_{OUT}$	0~ $V_{CC}$	V
Operating Temperature	$T_{opr}$	-40~85	°C

**DC ELECTRICAL CHARACTERISTICS**

PARAMETER	SYMBOL	TEST CONDITION	$V_{CC}$ (V)	$T_a = 25^{\circ}\text{C}$			$T_a = -40 \sim 85^{\circ}\text{C}$		UNIT	
				MIN.	TYP.	MAX.	MIN.	MAX.		
High - Level Input Voltage	$V_{IH}$		2.0	1.7	—	—	1.7	—	V	
			4.5	3.6	—	—	3.6	—		
			6.0	4.8	—	—	4.8	—		
Low - Level Input Voltage	$V_{IL}$		2.0	—	—	0.3	—	0.3	V	
			4.5	—	—	0.9	—	0.9		
			6.0	—	—	1.2	—	1.2		
High - Level Output Voltage	$V_{OH}$	$V_{IN} = V_{IL}$	$I_{OH} = -20\mu\text{A}$	2.0	1.8	2.0	—	1.9	—	V
				4.5	4.0	4.5	—	4.4	—	
				6.0	5.5	5.9	—	5.9	—	
		$V_{IN} = \text{GND}$	$I_{OH} = -4\text{ mA}$ $I_{OH} = -5.2\text{ mA}$	4.5	4.18	4.31	—	4.13	—	
				6.0	5.68	5.80	—	5.63	—	
				6.0	—	—	—	—	—	
Low - Level Output Voltage	$V_{OL}$	$V_{IN} = V_{IH}$	$I_{OL} = 20\mu\text{A}$	2.0	—	0.0	0.2	—	0.2	V
				4.5	—	0.0	0.5	—	0.5	
				6.0	—	0.1	0.5	—	0.5	
		$V_{IN} = V_{CC}$	$I_{OL} = 4\text{ mA}$ $I_{OL} = 5.2\text{ mA}$	4.5	—	0.17	0.26	—	0.33	
				6.0	—	0.18	0.26	—	0.33	
				6.0	—	—	—	—	—	
Input Leakage Current	$I_{IN}$	$V_{IN} = V_{CC}$ or GND	6.0	—	—	±0.1	—	±1.0	$\mu\text{A}$	
Quiescent Supply Current	$I_{CC}$	$V_{IN} = V_{CC}$ or GND	6.0	—	—	1.0	—	10.0		

961001EBA2

- The products described in this document are subject to foreign exchange and foreign trade control laws.
- The information contained herein is presented only as a guide for the applications of our products. No responsibility is assumed by TOSHIBA CORPORATION for any infringements of intellectual property or other rights of the third parties which may result from its use. No license is granted by implication or otherwise under any intellectual property or other rights of TOSHIBA CORPORATION or others.
- The information contained herein is subject to change without notice.

1997-08-07 2/5

# ADV7604

# Preliminary Information

## BGA BALLOUT

	1	2	3	4	5	6	7	8	9	10	11	12	13	14	15	16	17	18	
A	DGND	RXD_2-	RXD_1-	RXD_0-	RXD_C-	DGND	RXC_2-	RXC_1-	RXC_0-	RXC_C-	TVDD	RXB_2-	RXB_1-	RXB_0-	RXB_C-	TVDD	TVDD	DGND	A
B	RXD_5V	RXD_2+	RXD_1+	RXD_0+	RXD_C+	TVDD	RXC_2+	RXC_1+	RXC_0+	RXC_C+	TVDD	RXB_2+	RXB_1+	RXB_0+	RXB_C+	TVDD	RXA_2+	RXA_2-	B
C	PWRDNB	TVDD	TVDD	CVDD	DGND	TVDD	TVDD	DGND	DGND	DGND	TVDD	TVDD	DGND	DGND	DGND	DGND	RXA_1+	RXA_1-	C
D	RXC_5V	RXB_5V	RXA_5V	DDCD_SDA	DDCC_SCL	DDCC_SDA	DDCC_SCL	CVDD	DGND	RTERM	CVDD	DDCB_SDA	DDCB_SCL	DDCA_SCL	DDCA_SDA	TVDD	RXA_0+	RXA_0-	D
E	DE	CEC													DGND	DGND	RXA_C+	RXA_C-	E
F	HS	VS_FIELD	EP_MISO	EP_MOSI											DGND	CVDD	TVDD	DGND	F
G	P1	P0	EP_CS	EP_SCK			DGND	DGND	DGND	DGND	PVDD	PVDD					TEST1	TEST2	G
H	P3	P2	RAW_VSYNCS	RAW_SYNCS			DGND	DGND	DGND	DGND	AGND	AGND		XTALP	AVDD	REFN	REFP		H
J	DGND	DGND	MCLKOUT	SPDIF			DVDD	DGND	DGND	DGND	AGND	AGND		XTALN	AVDD	AGND	AGND		J
K	P4	P5	LRCLK	SCLK			DVDD	DVDD	DGND	DGND	AGND	AVDD		AVDD	AVDD	AIN11	AIN12		K
L	P6	P7	I2S3	I2S2			DVDD	DVDD	DGND	DGND	AGND	AVDD		TRI8/VS_JN2	TRI7/HS_JN2	SYNC4	AIN10		L
M	P8	DGND	DGND	DGND			DVDD	DVDD	DGND	DGND	AGND	AVDD		TRI5	TR6	AGND	AGND		M
N	P9	DVDDIO	DVDDIO	DVDDIO										TRI3	TRI4	AIN8	AIN9		N
P	P10	P11	I2S0	I2S1										AVDD	AVDD	SYNC3	AIN7		P
R	P12	P13	DGND	DGND	SCL	DVDDIO	INT1	CLAMPIN	DVDDIO	DGND	FB_OUT	SHARED_EDID	HS_IN1	AGND	Y_Mux_out	TRI2	AGND	AGND	R
T	P14	P15	DGND	DGND	P25	DVDDIO	SDA	SYNC_OUT/INT2	DVDDIO	DGND	RESETB	AVLINK	VS_IN1	AGND	TRI1	SYNC2	AIN5	AIN6	T
U	P16	P17	P19	P21	P23	DGND	P26	DCLKIN	P28	DGND	P31	P33	P35	AGND	SYNC1	AVDD	AVDD	AIN4	U
V	DGND	P18	P20	P22	P24	DGND	P27	LLC	P29	DGND	P30	P32	P34	AGND	AIN1	AIN2	AIN3	AGND	V

PrB Analog



**CS42528**

**114 dB, 192 kHz 8-Ch Codec with S/PDIF Receiver**

**Features**

- Eight 24-bit D/A, two 24-bit A/D Converters
- 114 dB DAC / 114 dB ADC Dynamic Range
- -100 dB THD+N
- System Sampling Rates up to 192 kHz
- S/PDIF Receiver Compatible with EIAJ CP1201 and IEC-60958
- Recovered S/PDIF Clock or System Clock Selection
- 8:2 S/PDIF Input MUX
- ADC High-pass Filter for DC Offset Calibration
- Expandable ADC Channels and One-line Mode Support
- Digital Output Volume Control with Soft Ramp
- Digital +/-15dB Input Gain Adjust for ADC
- Differential Analog Architecture
- Supports logic levels between 5 V and 1.8 V.

**General Description**

The CS42528 codec provides two analog-to-digital and eight digital-to-analog delta-sigma converters, as well as an integrated S/PDIF receiver, in a 64-pin LQFP package.

The CS42528 integrated S/PDIF receiver supports up to eight inputs, clock recovery circuitry and format auto-detection. The internal stereo ADC is capable of independent channel gain control for single-ended or differential analog inputs. All eight channels of DAC provide digital volume control and differential analog outputs. The general purpose outputs may be driven high or low, or mapped to a variety of DAC mute controls or ADC overflow indicators.

The CS42528 is ideal for audio systems requiring wide dynamic range, negligible distortion and low noise, such as A/V receivers, DVD receivers, digital speaker and automotive audio systems.

**ORDERING INFORMATION**

CS42528-CQZ	-10° to 70° C	64-pin LQFP	Lead Free
CS42528-DQZ	-40° to 85° C	64-pin LQFP	Lead Free
CDB42528		Evaluation Board	

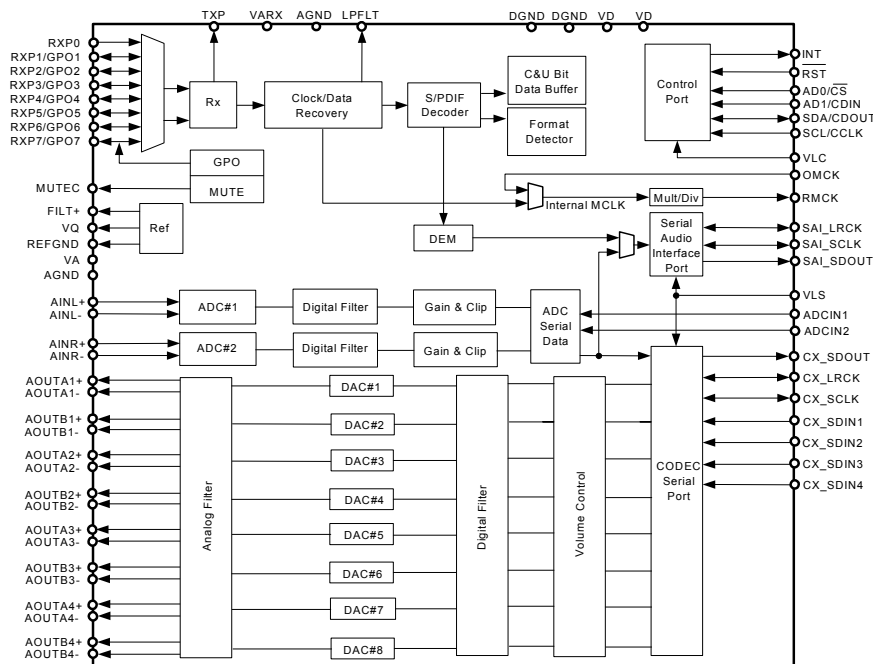

**Preliminary Product Information**

This document contains information for a new product. Cirrus Logic reserves the right to modify this product without notice.

Cirrus Logic, Inc.  
http://www.cirrus.com

Copyright © Cirrus Logic, Inc. 2005  
(All Rights Reserved)

JAN '05  
DS586PP5

## 8. Device Pin-Out Diagram

### 8.1 128-Pin LQFP Pin-Out Diagram

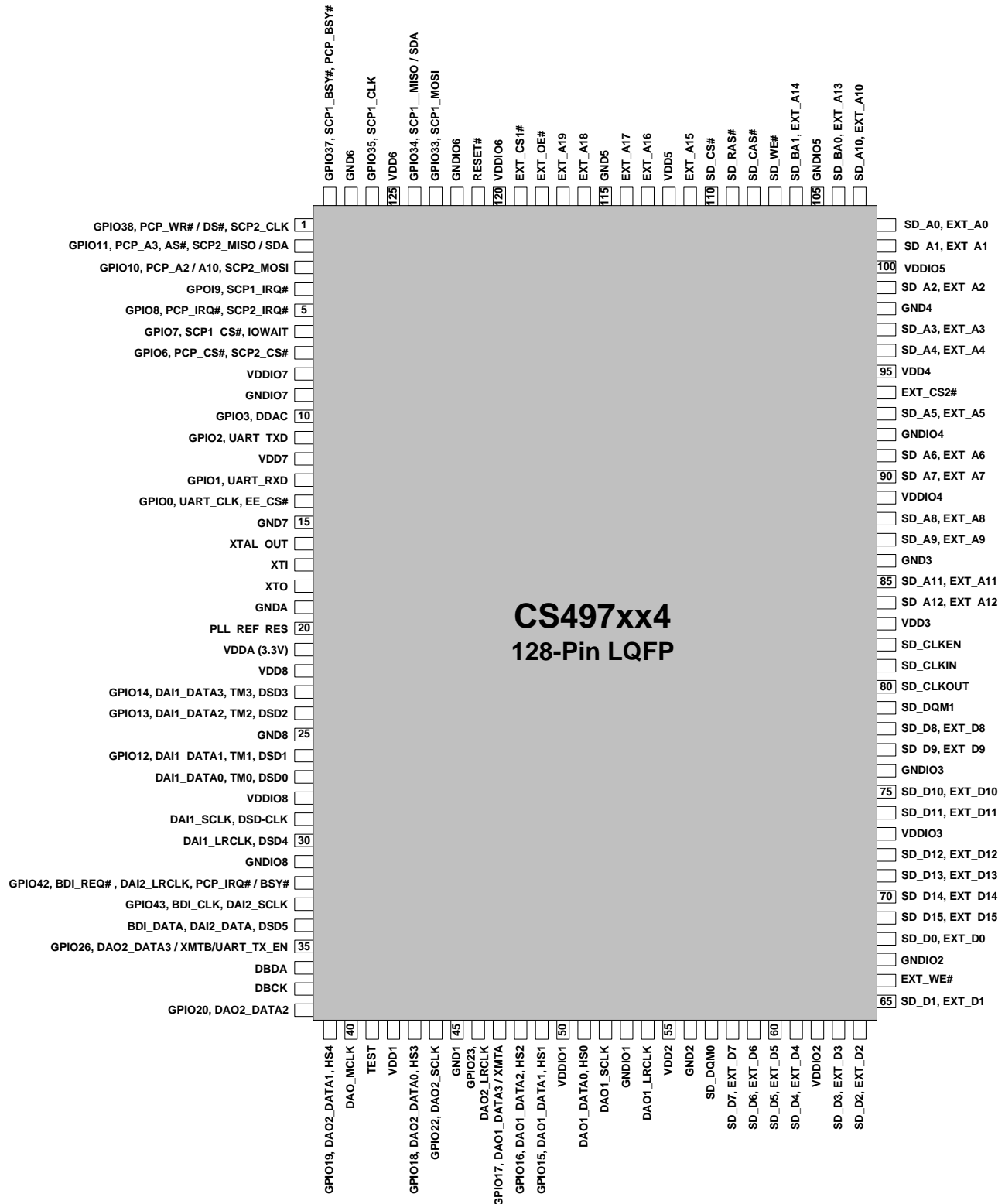

Figure 20. 128-Pin LQFP Pin-Out Diagram

### 8.2 144-Pin LQFP Pin-Out Diagram

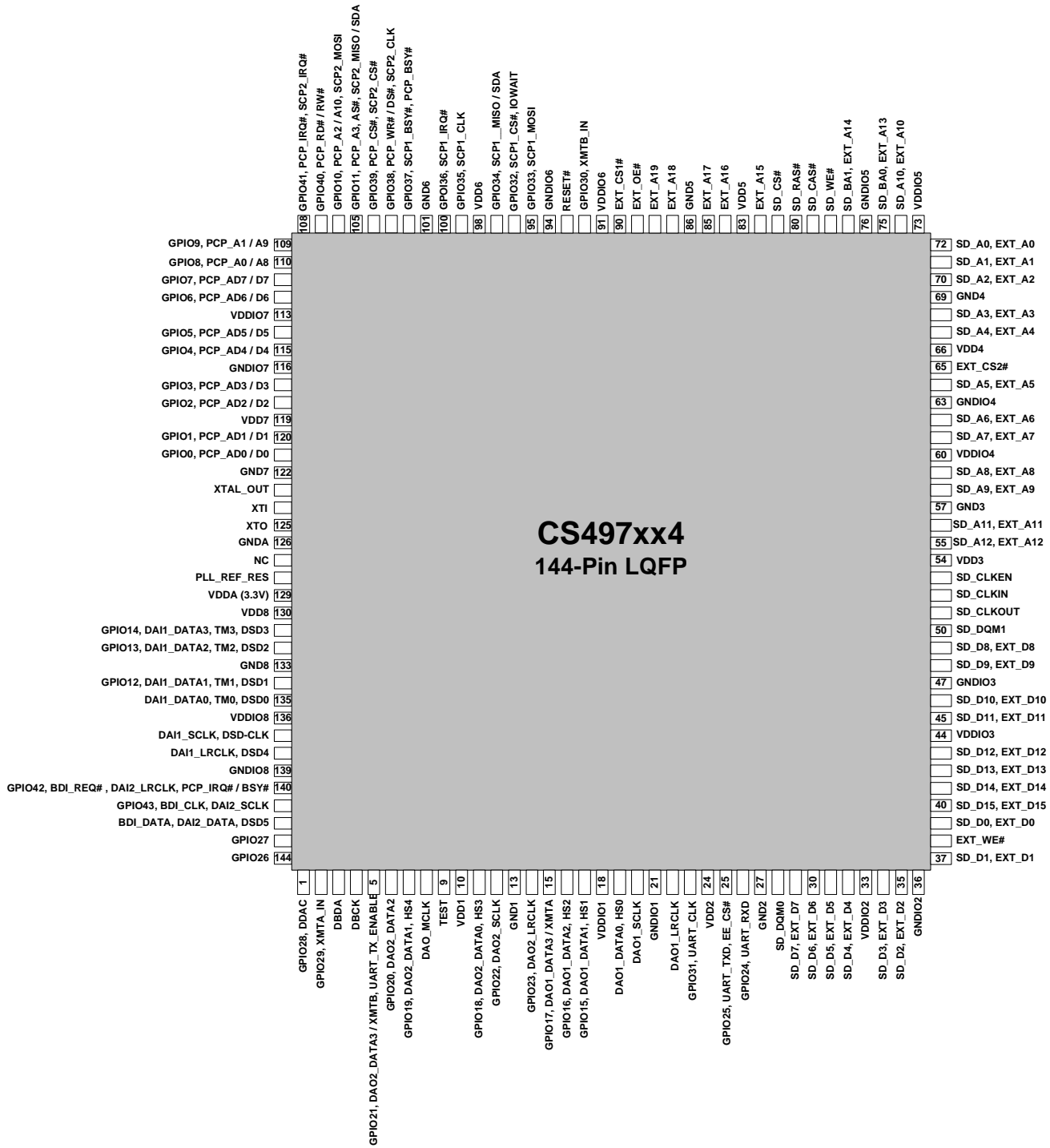
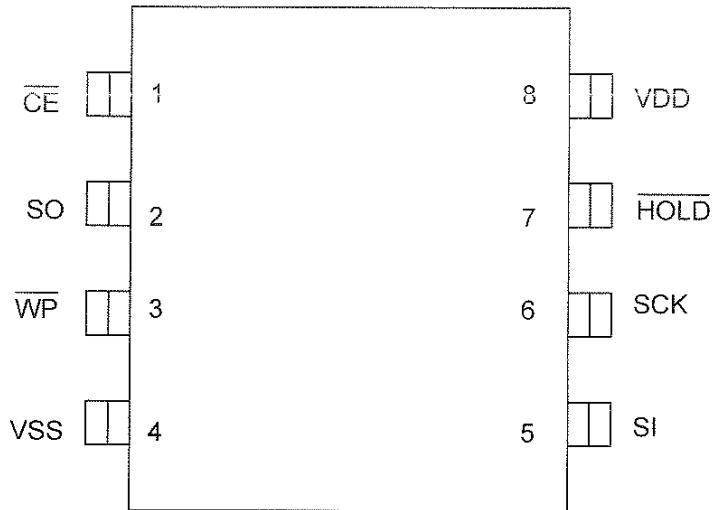
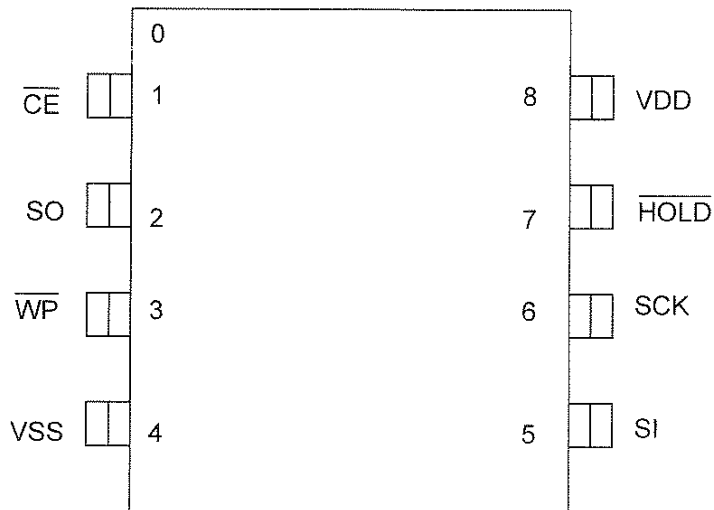

Figure 21. 144-Pin LQFP Pin-Out Diagram



**ESMT****F25L008A****PIN CONFIGURATIONS****8-PIN SOIC****8-PIN PDIP**

**ESMT****F25L008A****PIN Description**

Symbol	Pin Name	Functions
SCK	Serial Clock	To provide the timing for serial input and output operations
SI	Serial Data Input	To transfer commands, addresses or data serially into the device. Data is latched on the rising edge of SCK.
SO	Serial Data Output	To transfer data serially out of the device. Data is shifted out on the falling edge of SCK.
$\overline{\text{CE}}$	Chip Enable	To activate the device when $\overline{\text{CE}}$ is low.
$\overline{\text{WP}}$	Write Protect	The Write Protect ( $\overline{\text{WP}}$ ) pin is used to enable/disable BPL bit in the status register.
$\overline{\text{HOLD}}$	Hold	To temporarily stop serial communication with SPI flash memory without resetting the device.
VDD	Power Supply	To provide power.
VSS	Ground	

4 TERMINAL LOW DROP VOLTAGE REGULATOR

The KIA78R×× Series are Low Drop Voltage Regulator suitable for various electronic equipments. It provides constant voltage power source with TO-220 4 terminal lead full molded PKG. The Regulator has multi function such as over current protection, overheat protection and ON/OFF control.

FEATURES

- 1.0A Output Low Drop Voltage Regulator.
- Built in ON/OFF Control Terminal.
- Built in Over Current Protection, Over Heat Protection Function.

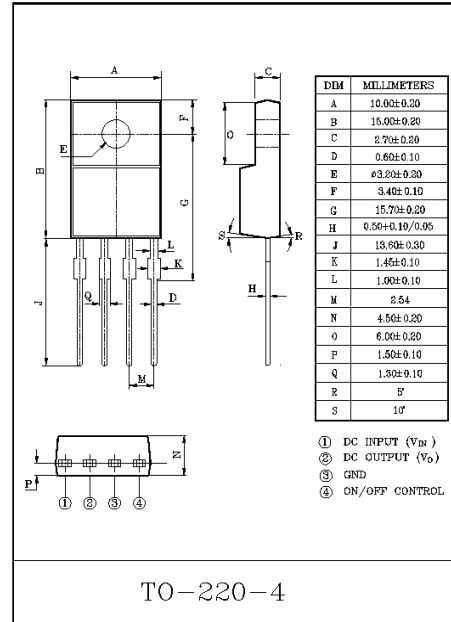

MAXIMUM RATINGS (Ta=25°C)

CHARACTERISTIC	SYMBOL	RATING	UNIT	Remark
Input Voltage	V <sub>IN</sub>	35	V	-
ON/OFF Control Voltage	V <sub>C</sub>	35	V	-
Output Current	I <sub>O</sub>	1	A	-
Power Dissipation 1	P <sub>d1</sub>	1.5	W	No heatsink
Power Dissipation 2	P <sub>d2</sub>	15	W	with heatsink
Junction Temperature	T <sub>j</sub>	125	°C	-
Operating Temperature	T <sub>opr</sub>	-20~80	°C	-
Storage Temperature	T <sub>stg</sub>	-30~125	°C	-
Soldering Temperature (10sec)	T <sub>sol</sub>	260	°C	-



# SEMICONDUCTOR TECHNICAL DATA

## KIA1117S/F00~ KIA1117S/F50 BIPOLAR LINEAR INTEGRATED CIRCUIT

### LOW DROP FIXED AND ADJUSTABLE POSITIVE VOLTAGE REGULATOR

The KIA1117S/F × × is a Low Drop Voltage Regulator able to provide up to 1A of output current, available even in adjustable version (Vref=1.25V)

#### FEATURES

- Low Dropout Voltage : 1.1V/Typ. (Iout=1.0A)
- Very Low Quiescent Current : 4.2mA/Typ.
- Output Current up to 1A
- Fixed Output Voltage of 1.5V, 1.8V, 2.5V, 2.85V, 3.3V, 5.0V
- Adjustable Version Availability : Vref=1.25V
- Internal Current and Thermal Limit
- Only 10µF for stability
- Available in ±2%(at 25 °C) and 4% in full Temperature range
- High Ripple Rejection : 80dB/Typ
- Temperature Range : 0 °C ~ 125 °C

#### LINE UP

ITEM	OUTPUT VOLTAGE (V)	PACKAGE
KIA1117S/F00	Adjustable (1.25~10V)	S : SOT-223 F : DPAK
KIA1117S/F15	1.5	
KIA1117S/F18	1.8	
KIA1117S/F25	2.5	
KIA1117S/F28	2.85	
KIA1117S/F33	3.3	
KIA1117S/F50	5.0	

#### MAXIMUM RATINGS (Ta=25 °C)

CHARACTERISTIC		SYMBOL	RATING	UNIT
Input Voltage		V <sub>IN</sub>	10	V
Output Current		S/F I <sub>OUT</sub>	1.0	A
Power Dissipation 1 (No heatsink)	S (Note)	P <sub>D1</sub>	1.0	W
	F		1.3	
Power Dissipation 2 (Without heatsink)	S	P <sub>D2</sub>	8.3	W
	F		13	
Operating Temperature		T <sub>opr</sub>	0~125	°C
Storage Temperature		T <sub>stg</sub>	-55~150	°C

Note) Package Mounted on FR-4 PCB 36 × 18 × 1.5mm.  
: mounting pad for the GND Lead min. 6cm<sup>2</sup>

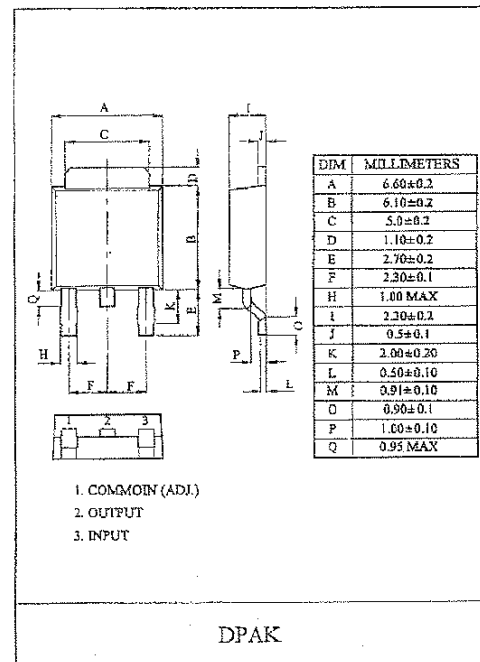
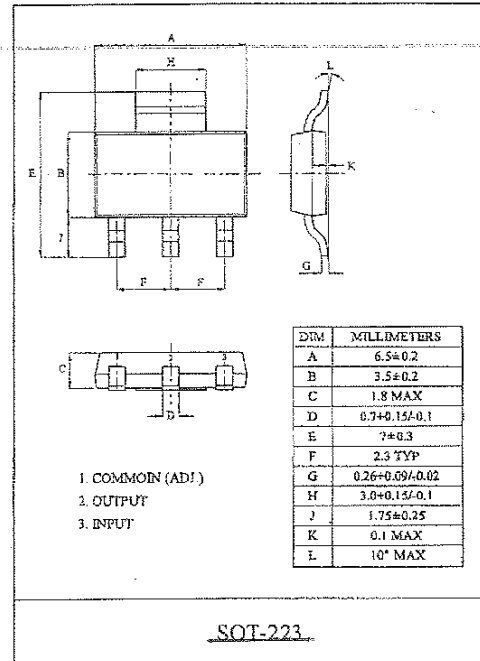

**4 TERMINAL 2A OUTPUT LOW DROP  
VOLTAGE REGULATOR**

The KIA278R × × Series are Low Drop Voltage Regulator suitable for various electronic equipments. It provides constant voltage power source with TO-220 4 terminal lead full molded PKG. The Regulator has multi function such as over current protection, overheat protection and ON/OFF control.

**FEATURES**

- 2.0A Output Low Drop Voltage Regulator.
- Built in ON/OFF Control Terminal.
- Built in Over Current Protection, Over Heat Protection Function.

**LINE UP**

ITEM	OUTPUT VOLTAGE (Typ.)	UNIT
KIA278R05PI	5	V
KIA278R06PI	6	
KIA278R08PI	8	
KIA278R09PI	9	
KIA278R10PI	10	
KIA278R12PI	12	
* KIA278R15PI	15	

\* Note) \* : Under Development.

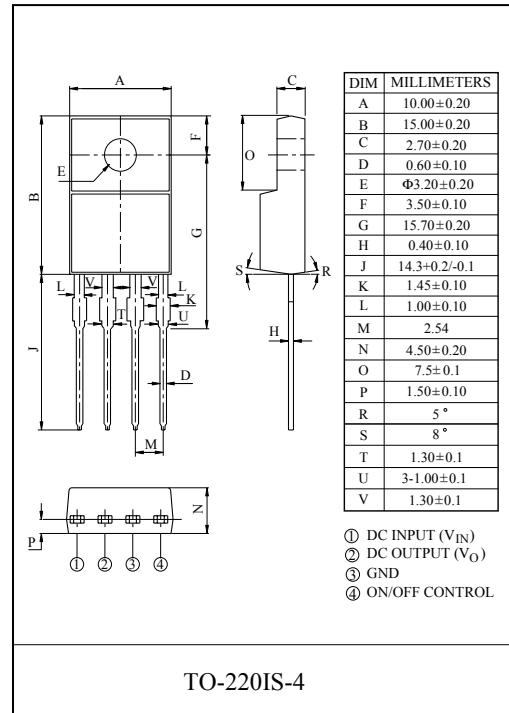

**MAXIMUM RATING (Ta=25°C)**

CHARACTERISTIC	SYMBOL	RATING	UNIT	Remark
Input Voltage	V <sub>IN</sub>	35	V	-
ON/OFF Control Voltage	V <sub>C</sub>	35	V	-
Output Current	I <sub>O</sub>	2	A	-
Power Dissipation 1	P <sub>d1</sub>	1.5	W	No heatsink
Power Dissipation 2	P <sub>d2</sub>	15	W	with heatsink
Junction Temperature	T <sub>j</sub>	125	°C	-
Operating Temperature	T <sub>opr</sub>	-20 ~ 80	°C	-
Storage Temperature	T <sub>stg</sub>	-30 ~ 125	°C	-
Soldering Temperature (10sec)	T <sub>sol</sub>	260	°C	-



# SEMICONDUCTOR TECHNICAL DATA

## KIA1117S/F00~ KIA1117S/F50 BIPOLAR LINEAR INTEGRATED CIRCUIT

### LOW DROP FIXED AND ADJUSTABLE POSITIVE VOLTAGE REGULATOR

The KIA1117S/F × × is a Low Drop Voltage Regulator able to provide up to 1A of output current, available even in adjustable version (Vref=1.25V)

#### FEATURES

- Low Dropout Voltage : 1.1V/Typ. (Iout=1.0A)
- Very Low Quiescent Current : 4.2mA/Typ.
- Output Current up to 1A
- Fixed Output Voltage of 1.5V, 1.8V, 2.5V, 2.85V, 3.3V, 5.0V
- Adjustable Version Availability : Vref=1.25V
- Internal Current and Thermal Limit
- Only 10µF for stability
- Available in ±2%(at 25 °C) and 4% in full Temperature range
- High Ripple Rejection : 80dB/Typ
- Temperature Range : 0 °C ~ 125 °C

#### LINE UP

ITEM	OUTPUT VOLTAGE (V)	PACKAGE
KIA1117S/F00	Adjustable (1.25~10V)	S : SOT-223 F : DPAK
KIA1117S/F15	1.5	
KIA1117S/F18	1.8	
KIA1117S/F25	2.5	
KIA1117S/F28	2.85	
KIA1117S/F33	3.3	
KIA1117S/F50	5.0	

#### MAXIMUM RATINGS (Ta=25 °C)

CHARACTERISTIC		SYMBOL	RATING	UNIT
Input Voltage		V <sub>IN</sub>	10	V
Output Current		S/F I <sub>OUT</sub>	1.0	A
Power Dissipation 1 (No heatsink)	S (Note)	P <sub>D1</sub>	1.0	W
	F		1.3	
Power Dissipation 2 (Without heatsink)	S	P <sub>D2</sub>	8.3	W
	F		13	
Operating Temperature		T <sub>opr</sub>	0~125	°C
Storage Temperature		T <sub>stg</sub>	-55~150	°C

Note) Package Mounted on FR-4 PCB 36 × 18 × 1.5mm.  
: mounting pad for the GND Lead min. 6cm<sup>2</sup>

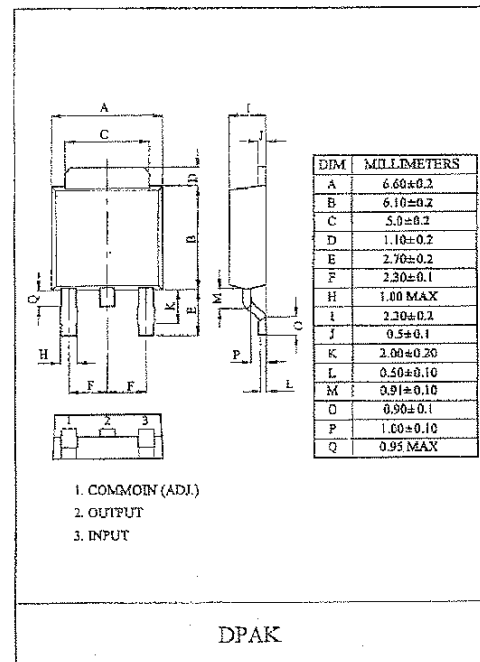
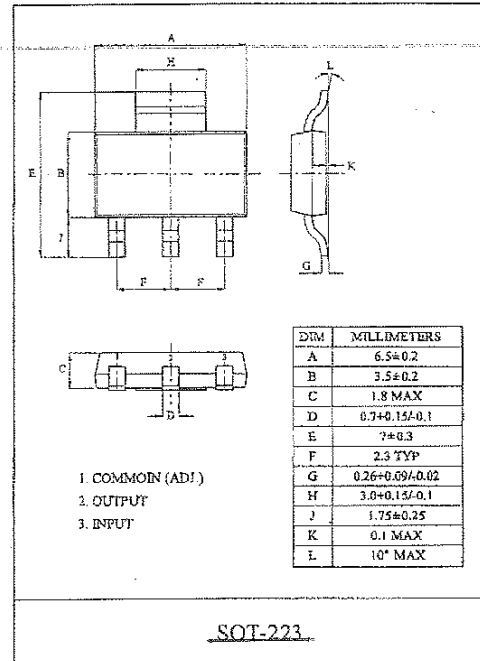





**SEMICONDUCTOR**  
TECHNICAL DATA

**KIA7805AP/API~**  
**KIA7824AP/API**  
BIPOLAR LINEAR INTEGRATED CIRCUIT

THREE TERMINAL POSITIVE VOLTAGE REGULATORS  
5V, 6V, 8V, 9V, 10V, 12V, 15V, 18V, 20V, 24V.

**FEATURES**

- Suitable for C-MOS, TTL, the Other Digital IC's Power Supply.
- Internal Thermal Overload Protection.
- Internal Short Circuit Current Limiting.
- Output Current in Excess of 1A.
- Satisfies IEC-65 Specification. (International Electrical Commission).

**MAXIMUM RATINGS (Ta=25°C)**

CHARACTERISTIC		SYMBOL	RATING	UNIT
Input Voltage	KIA7805AP/API~ KIA7815AP/API	V <sub>IN</sub>	35	V
	KIA7818AP/API~ KIA7824AP/API		40	
Power Dissipation (Tc=25°C)		P <sub>D</sub>	20.8	W
Power Dissipation (Without Heatsink)	KIA7805API~ KIA7824API	P <sub>D</sub>	2.0	W
Operating Junction Temperature		T <sub>j</sub>	-30~150	°C
Storage Temperature		T <sub>stg</sub>	-55~150	°C

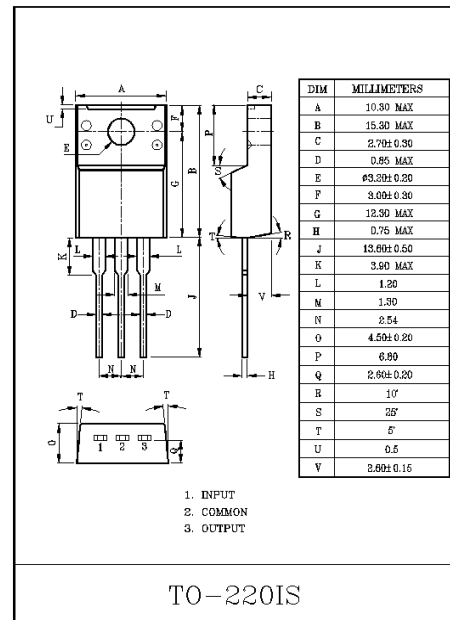
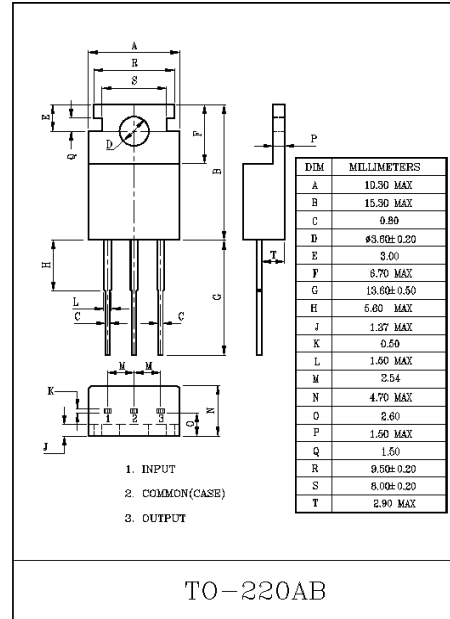

THREE TERMINAL POSITIVE VOLTAGE REGULATORS  
5V, 6V, 8V, 9V, 10V, 12V, 15V, 18V, 20V, 24V.

### FEATURES

- Suitable for C-MOS, TTL, the Other Digital IC's Power Supply.
- Internal Thermal Overload Protection.
- Internal Short Circuit Current Limiting.
- Output Current in Excess of 1A.
- Satisfies IEC-65 Specification. (International Electronical Commission).
- Package is DPAK.

MAXIMUM RATINGS (Ta=25 °C)

CHARACTERISTIC		SYMBOL	RATING	UNIT
Input Voltage	KIA7805AF ~ KIA7815AF	V <sub>IN</sub>	35	V
	KIA7818AF ~ KIA7824AF		40	
Power Dissipation (Tc=25 °C)		P <sub>D</sub>	12	W
Power Dissipation (Without Heatsink)	KIA7805AF ~ KIA7824AF	P <sub>D</sub>	1.3	W
Operating Junction Temperature		T <sub>j</sub>	-30 ~ 150	°C
Storage Temperature		T <sub>stg</sub>	-55 ~ 150	°C

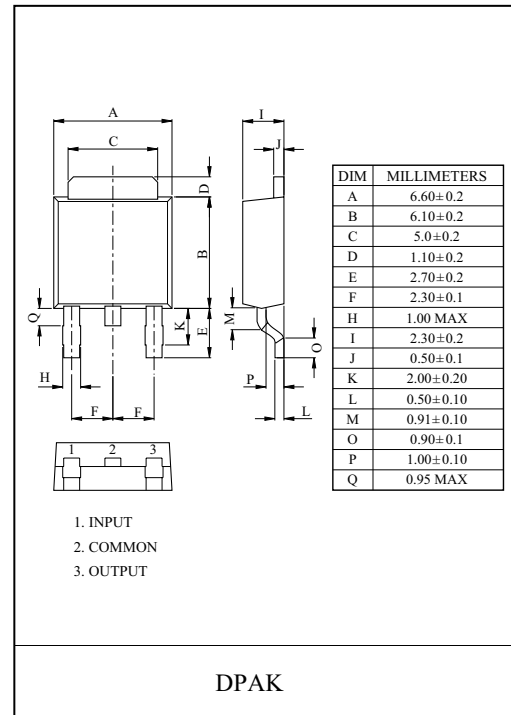

### EQUIVALENT CIRCUIT

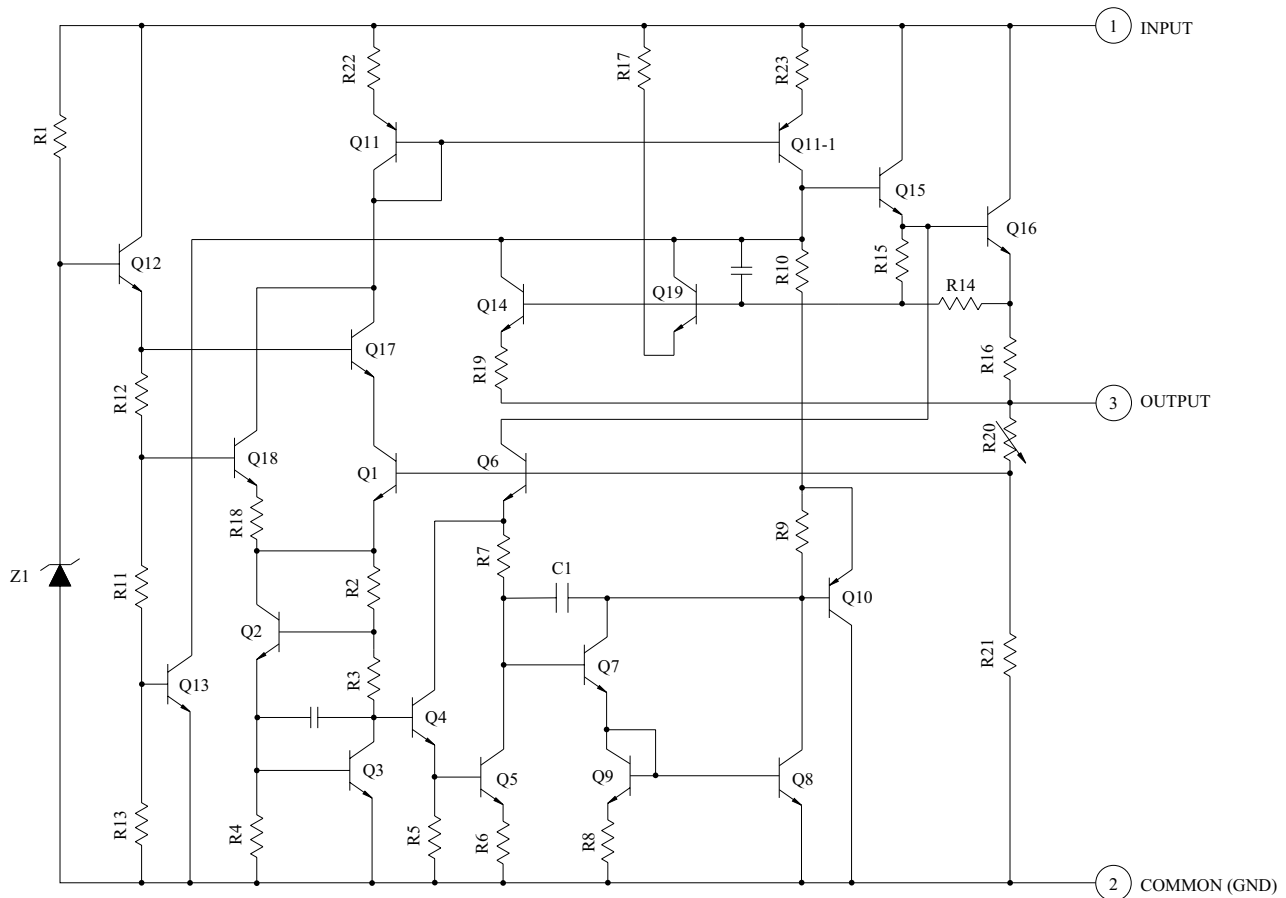

1A THREE TERMINAL NEGATIVE VOLTAGE REGULATORS  
-5V, -6V, -8V, -9V, -10V, -12V, -15V, -18V, -20V, -24V

**FEATURES:**

- Suitable for C-MOS, TTL, and the other digital IC power supply.
- Internal thermal overload protecting.
- Internal short circuit current limiting.
- Output current in excess of 1.0A.

**MAXIMUM RATINGS (Ta=25°C)**

CHARACTERISTIC		SYMBOL	RATING	UNIT
Input Voltage	KIA7905P/PI~ KIA7915P/PI	V <sub>IN</sub>	-35	V
	KIA7918P/PI~ KIA7924P/PI		-40	
Power Dissipation (Tc=25°C)	P <sub>D</sub>	20.8	W	
Operating Junction Temperature	T <sub>j</sub>	-30~150	°C	
Operating Temperature	T <sub>opr</sub>	-30~75	°C	
Storage Temperature	T <sub>stg</sub>	-55~150	°C	

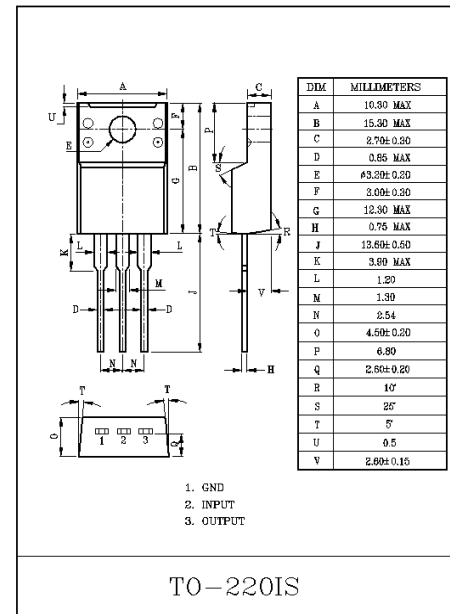
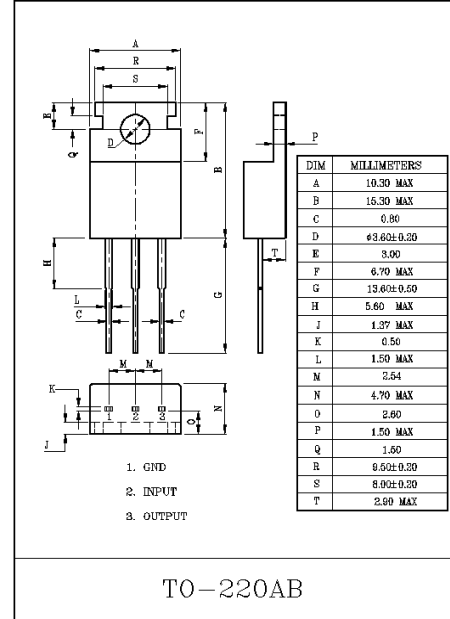

LC74763, 74763M

Pin Assignment

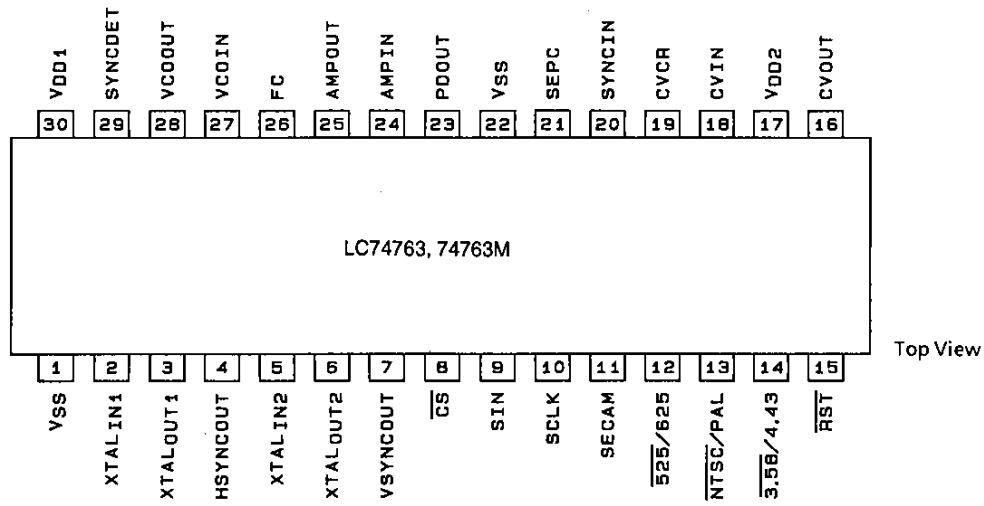

A03518

Serial Data Input Timing

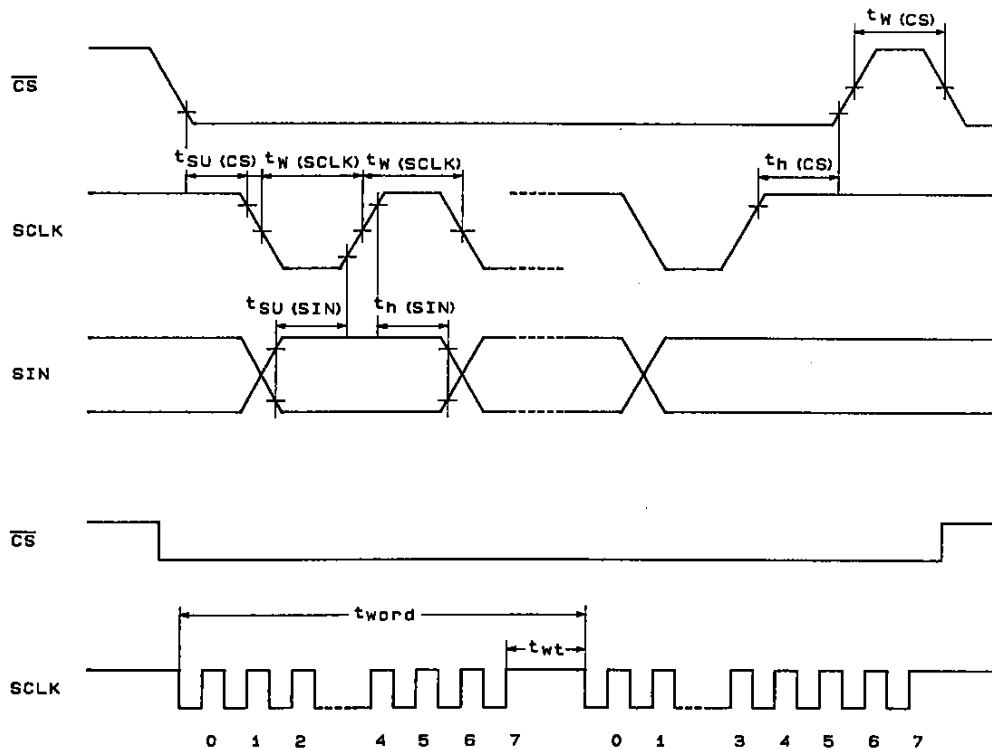

A03519

# ESMT

# M12L16161A

## SDRAM

## 512K x 16Bit x 2Banks Synchronous DRAM

### FEATURES

- JEDEC standard 3.3V power supply
- LVTTTL compatible with multiplexed address
- Dual banks operation
- MRS cycle with address key programs
  - CAS Latency (2 & 3 )
  - Burst Length (1, 2, 4, 8 & full page)
  - Burst Type (Sequential & Interleave)
- All inputs are sampled at the positive going edge of the system clock
- Burst Read Single-bit Write operation
- DQM for masking
- Auto & self refresh
- 32ms refresh period (2K cycle)

### GENERAL DESCRIPTION

The M12L16161A is 16,777,216 bits synchronous high data rate Dynamic RAM organized as 2 x 524,288 words by 16 bits, fabricated with high performance CMOS technology. Synchronous design allows precise cycle control with the use of system clock I/O transactions are possible on every clock cycle. Range of operating frequencies, programmable burst length and programmable latencies allow the same device to be useful for a variety of high bandwidth, high performance memory system applications.

### ORDERING INFORMATION

Part NO.	MAX Freq.	PACKAGE	COMMENTS
M12L16161A-5TG	200MHz	TSOP(II)	Pb-free
M12L16161A-7TG	143MHz	TSOP(II)	Pb-free
M12L16161A-7BG	143MHz	VFBGA	Pb-free

### PIN CONFIGURATION (TOP VIEW)

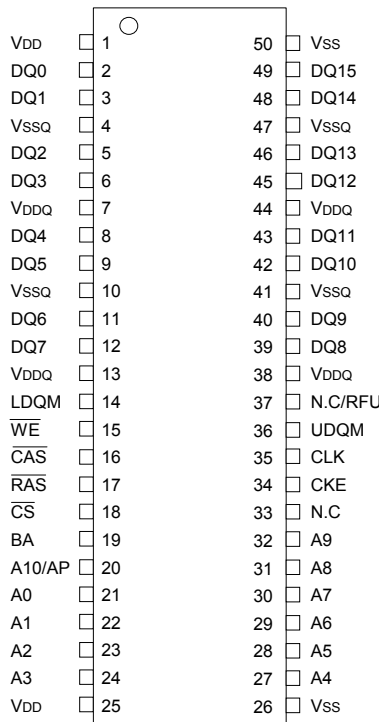

50PIN TSOP(II)  
(400mil x 825mil)  
(0.8 mm PIN PITCH)

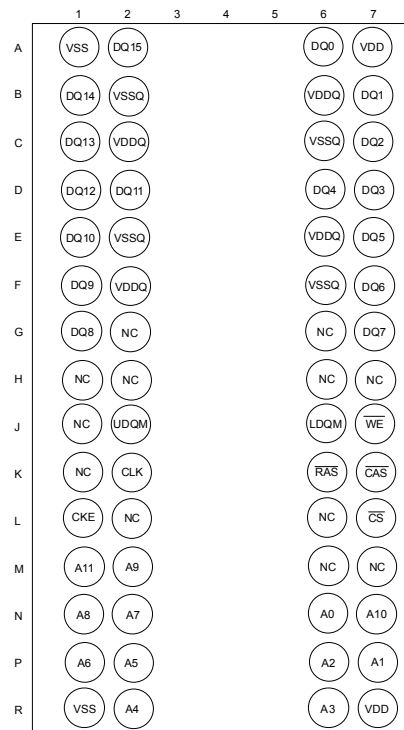

60 Ball VFBGA  
(6.4x10.1mm)  
(0.65mm ball pitch)

## M24C64, M24C32

### SUMMARY DESCRIPTION

These I<sup>2</sup>C-compatible electrically erasable programmable memory (EEPROM) devices are organized as 8192 x 8 bits (M24C64) and 4096 x 8 bits (M24C32).

Figure 2. Logic Diagram

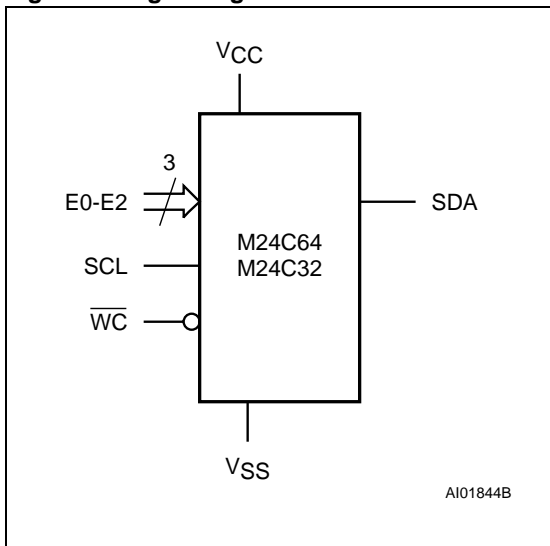

I<sup>2</sup>C uses a two-wire serial interface, comprising a bi-directional data line and a clock line. The devices carry a built-in 4-bit Device Type Identifier code (1010) in accordance with the I<sup>2</sup>C bus definition.

The device behaves as a slave in the I<sup>2</sup>C protocol, with all memory operations synchronized by the serial clock. Read and Write operations are initiated by a Start condition, generated by the bus master. The Start condition is followed by a Device Select Code and Read/Write bit (RW) (as described in Table 3.), terminated by an acknowledge bit.

When writing data to the memory, the device inserts an acknowledge bit during the 9<sup>th</sup> bit time, following the bus master's 8-bit transmission. When data is read by the bus master, the bus master acknowledges the receipt of the data byte in the same way. Data transfers are terminated by a Stop condition after an Ack for Write, and after a NoAck for Read.

Table 2. Signal Names

E0, E1, E2	Chip Enable
SDA	Serial Data
SCL	Serial Clock
WC	Write Control
VCC	Supply Voltage
VSS	Ground

#### Power On Reset: VCC Lock-Out Write Protect

In order to prevent data corruption and inadvertent Write operations during Power-up, a Power On Reset (POR) circuit is included. At Power-up, the internal reset is held active until VCC has reached the Power On Reset (POR) threshold voltage, and all operations are disabled – the device will not respond to any command. In the same way, when VCC drops from the operating voltage, below the Power On Reset (POR) threshold voltage, all operations are disabled and the device will not respond to any command.

A stable and valid VCC (as defined in Table 9. and Table 10.) must be applied before applying any logic signal.

Figure 3. DIP, SO, TSSOP and UDFPN Connections

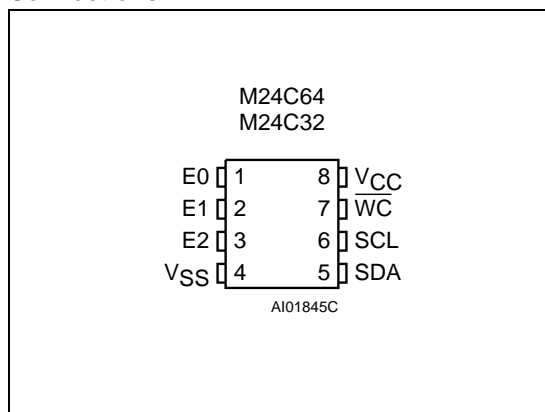

Note: See PACKAGE MECHANICAL section for package dimensions, and how to identify pin-1.







**LOW-NOISE DUAL OPERATIONAL AMPLIFIER**

■ **GENERAL DESCRIPTION**

The NJM2068 is a high performance, low noise dual operational amplifier. This amplifier features popular pin-out, superior noise performance, and superior total harmonic distortion. This amplifier also features guaranteed noise performance with substantially higher gain-bandwidth product and slew rate which far exceeds that of the 4558 type amplifier. The specially designed low noise input transistors allow the NJM2068 to be used in very low noise signal processing applications such as audio preamplifiers and servo error amplifier.

■ **PACKAGE OUTLINE**

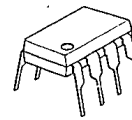

NJM2068D



NJM2068M



NJM2068V

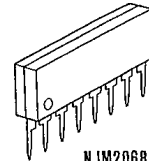

NJM2068L

■ **FEATURES**

- Operating Voltage (±4V ~ ±18V)
- Low Total Harmonic Distortion (0.001% typ.)
- Low Noise Voltage (FLAT+JISA, 0.56 μV typ.)
- High Slew Rate (6V/μs typ.)
- Unity Gain Bandwidth (27MHz @f=10kHz)
- Package Outline DIP8, DMP8, SIP8, SSOP8
- Bipolar Technology

**4**

■ **PIN CONFIGURATION**

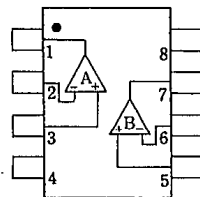

NJM2068D  
NJM2068M  
NJM2068V

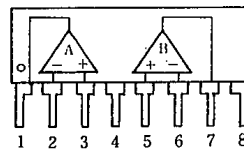

NJM2068L

**PIN FUNCTION**

1. A OUTPUT
2. A-INPUT
3. A+INPUT
4. V-
5. B+INPUT
6. B-INPUT
7. B OUTPUT
8. V+

■ **EQUIVALENT CIRCUIT (1/2 Shown)**

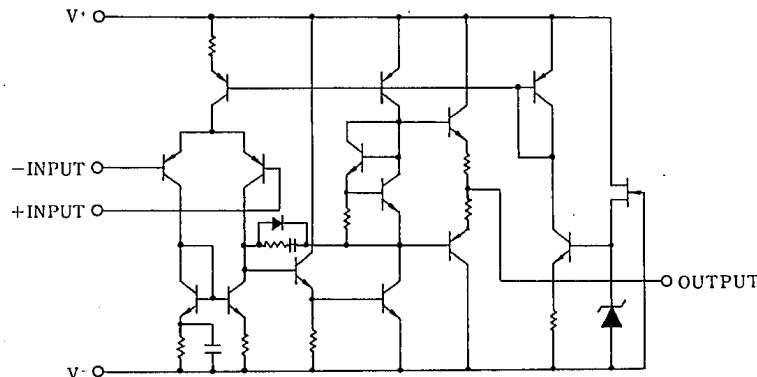



# NJM2391

## LOW DROPOUT VOLTAGE REGULATOR

### ■ GENERAL DESCRIPTION

The NJM2391 is low dropout voltage regulators featuring high precision voltage.

It is suitable for Notebook PCs, PC cards and hard disks where 3.3V need to be generated from 5V supply.

A small TO-252 package is adopted for the space saving.

### ■ PACKAGE OUTLINE

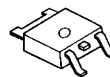

NJM2391DL1

### ■ FEATURES

- Output Current  $I_o(\text{max.})=1\text{A}$
- High Precision Output Voltage  $V_o\pm 1\%$
- Low Dropout Voltage  $\Delta V_{I-O} = 1.1\text{V typ. At } I_o=1\text{A}$
- Internal Excessive Voltage Protection Circuit
- Internal Short Circuit Current Limit
- Internal Thermal Overload Protection
- Bipolar Technology
- Package Outline TO-252

### ■ PIN CONFIGURATION

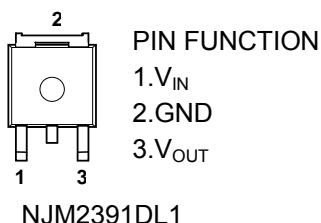

### ■ ABSOLUTE MAXIMUM RATINGS (Ta=25°C)

PARAMETER	SYMBOL	RATINGS	UNIT
Input Voltage	$V^+$	+10	V
Power Dissipation	$P_D$	TO-252 8 (Tc=25°C) 0.8(Ta≤25°C)	W
Operating Temperature	Topr	-40 ~ +85	°C
Storage Temperature	Tstg	-50 ~ +125	°C

### ■ OUTPUT VOLTAGE RANK LIST

Device Name	$V_{OUT}$
NJM2391DL1-25	2.5V
NJM2391DL1-26	2.6V
NJM2391DL1-28	2.85V
NJM2391DL1-03	3.0V
NJM2391DL1-33	3.3V
NJM2391DL1-35	3.5V
NJM2391DL1-05	5.0V



# NJM2595

## 5-INPUT 3-OUTPUT VIDEO SWITCH

### ■ GENERAL DESCRIPTION

The **NJM2595** is a 5-input 3-output video switch. Its switches select one from five signals received from VTR, TV, DVD, TV-GAME and others.

The NJM2595 is designed for audio items, such as AV amplifier and others.

### ■ PACKAGE OUTLINE

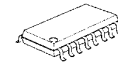
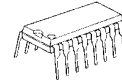

**NJM2595D NJM2595M**

### ■ FEATURES

- 5-input 3-output
- Operating Voltage  $\pm 4.0$  to  $\pm 6.5V$
- Operating current  $\pm 15mA$ typ. at  $V_{cc}=\pm 5V$
- Crosstalk  $-65dB$ typ.
- Internal 6dB Amplifier
- Internal  $75\Omega$  Driver
- Bipolar Technology
- Package Outline DIP16,DMP16

### ■ PIN CONFIGURATION and BLOCK DIAGRAM

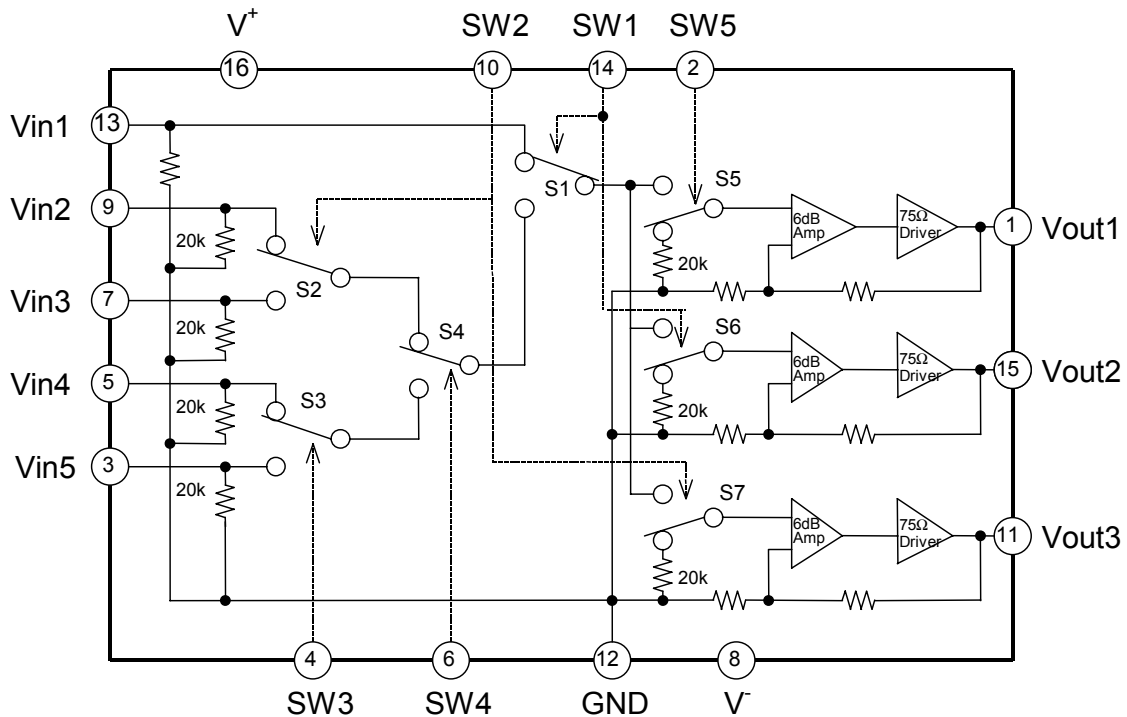



# NJM2845/46

## LOW DROPOUT VOLTAGE REGULATOR

### ■ GENERAL DESCRIPTION

The NJM2845 is low dropout voltage regulator. Advanced Bipolar technology achieves low noise, high ripple rejection and low quiescent current.

NJM2845 is 3 terminal type and NJM2846 is ON/OFF control built in type. These product can be selected according to the applications.

### ■ PACKAGE OUTLINE

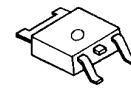

NJM2845DL1

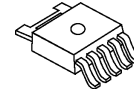

NJM2846DL3

### ■ FEATURES

- High Ripple Rejection      75dB typ. (f=1kHz,3V Version)
- Output Noise Voltage       $V_{no}=45\mu V_{rms}$  typ. ( $V_o=3V$  Version)
- Output capacitor with 2.2 $\mu F$  ceramic capacitor ( $V_o\geq 2.6V$ )
- Output Current               $I_o(max.)=800mA$
- High Precision Output       $V_o \pm 1.0\%$
- Low Dropout Voltage      0.18V typ. ( $I_o=500mA$ )
- ON/OFF Control              (NJM2846)
- Internal Short Circuit Current Limit
- Internal Thermal Overload Protection
- Bipolar Technology
- Package Outline              TO-252-3 (NJM2845DL1), TO-252-5 (NJM2846DL3)

### ■ PIN CONFIGURATION

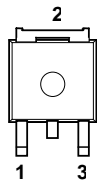

NJM2845DL1

- 1.  $V_{IN}$
- 2. GND
- 3.  $V_{OUT}$

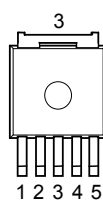

NJM2846DL3

- 1. CONTROL
- 2.  $V_{IN}$
- 3. GND
- 4.  $V_o$
- 5. NC

### ■ EQUIVALENT CIRCUIT

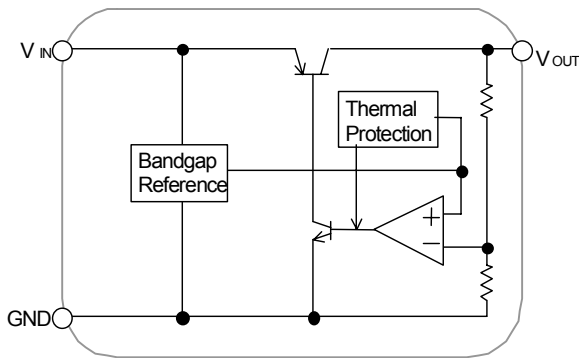

NJM2845DL1

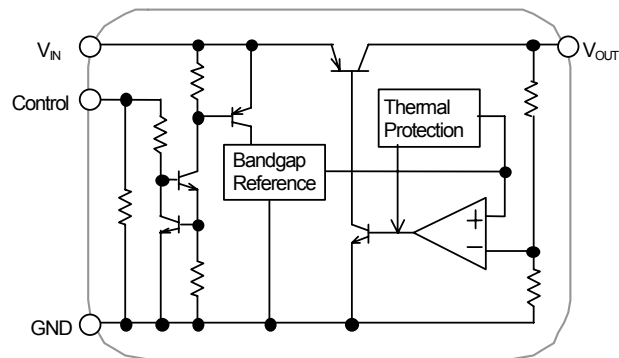

NJM2846DL3

## DUAL HIGH CURRENT OPERATIONAL AMPLIFIER

### ■ GENERAL DESCRIPTION

The NJM4556A integrated circuit is a high-gain, high output current dual operational amplifier capable of driving  $\pm 70\text{mA}$  into  $150\ \Omega$  loads ( $\pm 10.5\text{V}$  output voltage), and operating low supply voltage ( $V^+/V^- = \pm 2\text{V} \sim$ ).

The NJM4556A combines many of the fetures of the popular NJM4558 as well as having the capability of driving  $150\ \Omega$  loads. In addition, the wide band-width, low noise, high slew rate and low distortion of the NJM4556A make it ideal for many audio, telecommu- nications and instrumentation applications.

### ■ FEATURES

- Operating Voltage ( $\pm 2\text{V} \sim \pm 18\text{V}$ )
- High Output Current ( $I_o = 70\text{mA}$ )
- Slew Rate ( $3\text{V}/\mu\text{s}$  typ.)
- Gain Band Width Product ( $8\text{MHz}$  typ.)
- Package Outline DIP8, DMP8, SIP8, SSOP8
- Bipolar Technology

### ■ PACKAGE OUTLINE

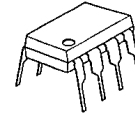

NJM4556AD



NJM4556AM

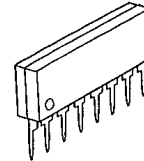

NJM4556AL

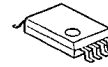

NJM4556AV

### ■ PIN CONFIGURATION

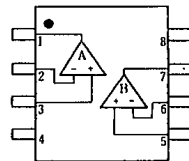

NJM4556AD.  
NJM4556AM  
NJM4556AV

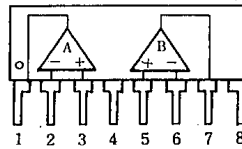

NJM4556AL

#### PIN FUNCTION

1. A OUTPUT
2. A-INPUT
3. A+INPUT
4.  $V^-$
5. B+INPUT
6. B-INPUT
7. B OUTPUT
8.  $V^+$

### ■ EQUIVALENT CIRCUIT (1/2 Shown)

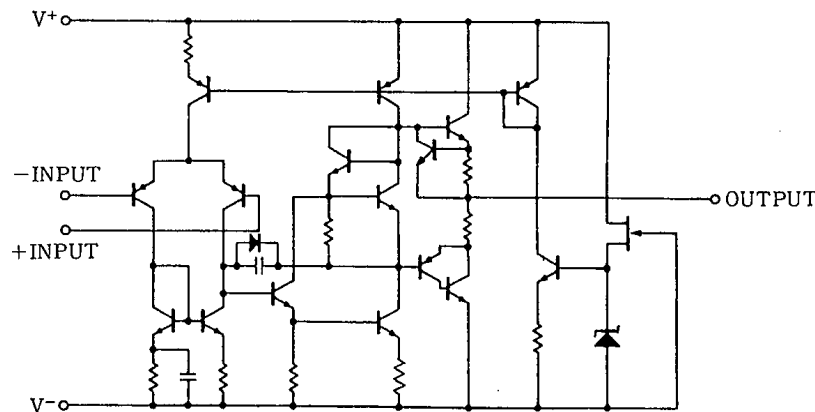

# NJW1197C

## ■ PIN FUNCTION

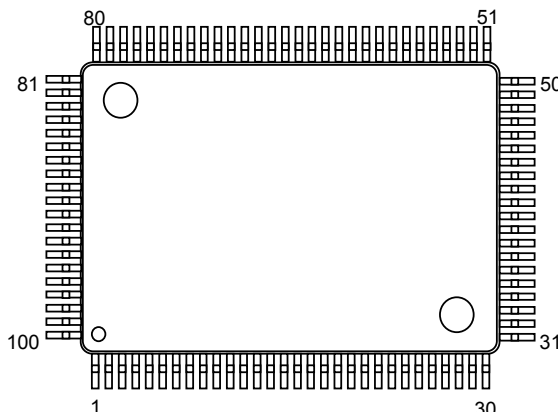

No.	SYMBOL	FUNCTION	No.	SYMBOL	FUNCTION
1	ROUT	Rch output	51	DCR_IN	"Multi-channel selector" Rch input
2	COUT	Cch output	52	DCR_OUT	"Input selector" Rch output
3	LSOUT	LSch output	53	GND	Ground
4	RSOUT	RSch output	54	DCL_IN	"Multi-channel selector" Lch input
5	LBOUT	LBch output	55	LBCL_OUT	"Input selector" Lch output
6	RBOU	RBch output	56	GND	Ground
7	SWOUT	SWch output	57	REC_B1R	"Input selector" Rch REC output B1
8	GND	Ground	58	REC_B1L	"Input selector" Lch REC output B1
9	FIL_BL2	Lch Bass filter terminal 2	59	REC_A4R	"Input selector" Rch REC output A4
10	FIL_BL1	Lch Bass filter terminal 1	60	REC_A4L	"Input selector" Lch REC output A4
11	FIL_TL	Lch Treble filter terminal	61	REC_A3R	"Input selector" Rch REC output A3
12	TCAP	Switching noise rejection capacitor	62	REC_A3L	"Input selector" Lch REC output A3
13	FIL_BR2	Rch Bass filter terminal 2	63	REC_A2R	"Input selector" Rch REC output A2
14	FIL_BR1	Rch Bass filter terminal 1	64	REC_A2L	"Input selector" Lch REC output A2
15	FIL_TR	Rch Treble filter terminal	65	REC_A1R	"Input selector" Rch REC output A1
16	V+	+ Power supply voltage input	66	REC_A1L	"Input selector" Lch REC output A1
17	ADR	Chip address select input	67	VDDOUT	Internal Digital +Power Supply Output
18	V-	- Power supply voltage input	68	DATA	Control data signal input
19	L1IN	"Input selector" Lch input 1	69	CLOCK	Clock signal input
20	DCCAP_SW	Switching noise rejection capacitor	70	LATCH	Latch signal input
21	R1IN	"Input selector" Rch input 1	71	MUTE	External mute control
22	DCCAP_RB	Switching noise rejection capacitor	72	FL+	"Input selector gain control" Lch no-inverted output
23	L2IN	"Input selector" Lch input 2	73	FL-	"Input selector gain control" Lch inverted output
24	DCCAP_LB	Switching noise rejection capacitor	74	FR+	"Input selector gain control" Rch no-inverted output
25	R2IN	"Input selector" Rch input 2	75	FR-	"Input selector gain control" Rch inverted output
26	DCCAP_RS	Switching noise rejection capacitor	76	GND	Ground
27	L3IN	"Input selector" Lch input 3	77	LSCIN	Multi-channel LSch input C
28	DCCAP_LS	Switching noise rejection capacitor	78	RSCIN	Multi-channel RSch input C
29	R3IN	"Input selector" Rch input 3	79	LBCIN	Multi-channel LBch input C
30	DCCAP_C	Switching noise rejection capacitor	80	RBCIN	Multi-channel RBch input C
31	L4IN	"Input selector" Lch input 4	81	GND	Ground
32	DCCAP_R	Switching noise rejection capacitor	82	LAIN	Multi-channel Lch input A
33	R4IN	"Input selector" Rch input 4	83	RAIN	Multi-channel Rch input A
34	DCCAP_L	Switching noise rejection capacitor	84	CAIN	Multi-channel Cch input A
35	L5IN	"Input selector" Lch input 5	85	LSAIN	Multi-channel LSch input A
36	GND	Ground	86	RSAIN	Multi-channel RSch input A
37	R5IN	"Input selector" Rch input 5	87	LBAIN	Multi-channel LBch input A
38	GND	Ground	88	RBAIN	Multi-channel RBch input A
39	L6IN	"Input selector" Lch input 6	89	SWAIN	Multi-channel SWch input A
40	L9IN	"Input selector" Lch input 9	90	GND	Ground
41	R6IN	"Input selector" Rch input 6	91	LBIN	Multi-channel Lch input B
42	R9IN	"Input selector" Rch input 9	92	RBIN	Multi-channel Rch input B
43	L7IN	"Input selector" Lch input 7	93	CBIN	Multi-channel Cch input B
44	L10IN	"Input selector" Lch input 10	94	LSBIN	Multi-channel LSch input B
45	R7IN	"Input selector" Rch input 7	95	RSBIN	Multi-channel RSch input B
46	R10IN	"Input selector" Rch input 10	96	LBBIN	Multi-channel LBch input B
47	L8IN	"Input selector" Lch input 8	97	RBBIN	Multi-channel RBch input B
48	L11IN	"Input selector" Lch input 11	98	SWBIN	Multi-channel SWch input B
49	R8IN	"Input selector" Rch input 8	99	GND	Ground
50	R11IN	"Input selector" Rch input 11	100	LOUT	Lch output

# NJW1321

## PIN CONFIGURATION

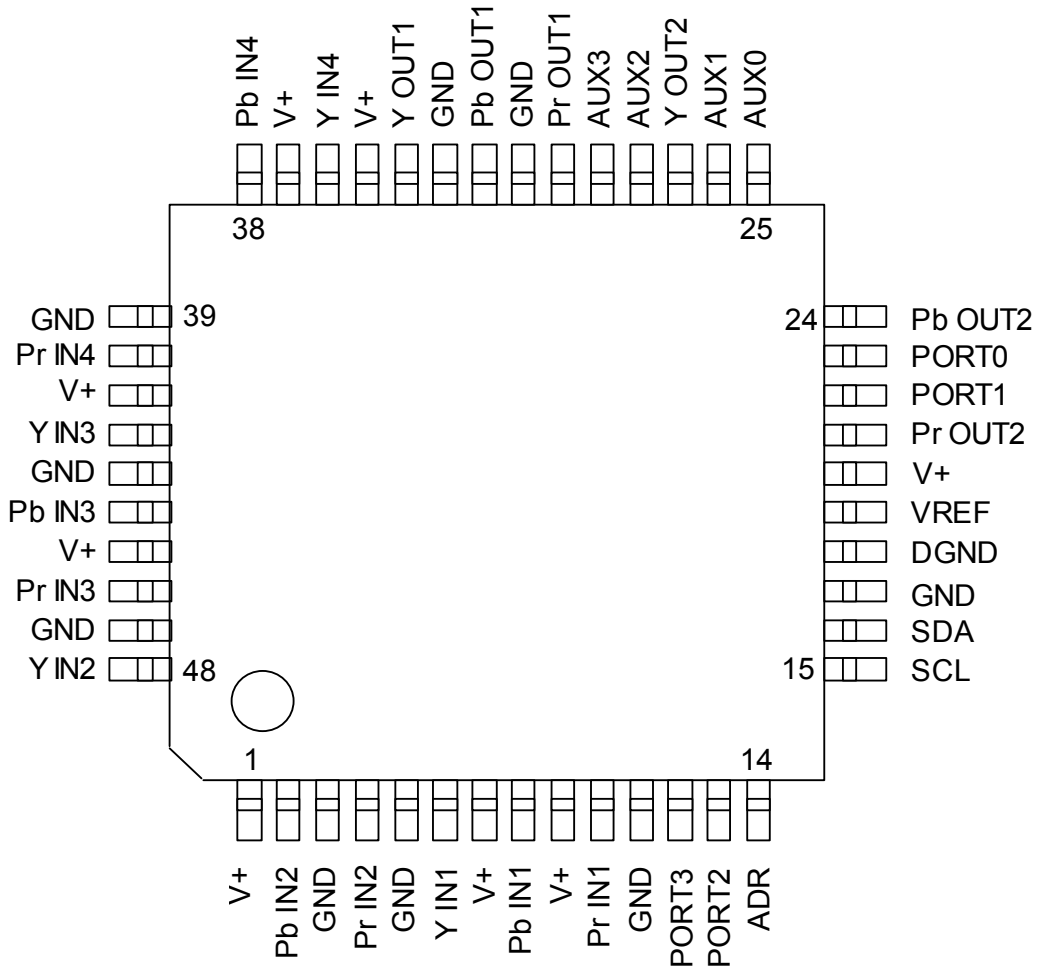

1. V+	13. PORT2	25. AUX0	37. V+
2. Pb IN2	14. ADR	26. AUX1	38. Pb IN4
3. GND	15. SCL	27. Y OUT2	39. GND
4. Pr IN2	16. SDA	28. AUX2	40. Pr IN4
5. GND	17. GND	29. AUX3	41. V+
6. Y IN1	18. DGND	30. Pr OUT1	42. Y IN3
7. V+	19. VREG	31. GND	43. GND
8. Pb IN1	20. V+	32. Pb OUT1	44. Pb IN3
9. V+	21. Pr OUT2	33. GND	45. V+
10. Pr IN1	22. PORT1	34. Y OUT1	46. Pr IN3
11. GND	23. PORT 0	35. V+	47. GND
12. PORT3	24. Pb OUT2	36. Y IN4	48. Y IN2



## PIN CONFIGURATION

• TO-92

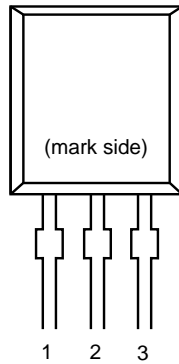

• SOT-89

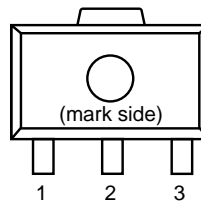

• SOT-23-5

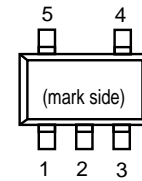

## PIN DESCRIPTION

• TO-92

Pin No.	Symbol
1	OUT
2	VDD
3	GND

• SOT-89

Pin No.	Symbol
1	OUT
2	VDD
3	GND

• SOT-23-5

Pin No.	Symbol
1	OUT
2	VDD
3	GND
4	NC
5	NC

6 外形

Package information

6-1外形、寸法

Package type, physical dimensions

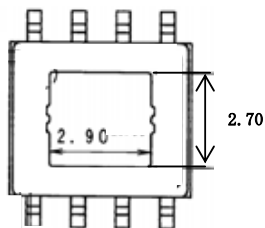
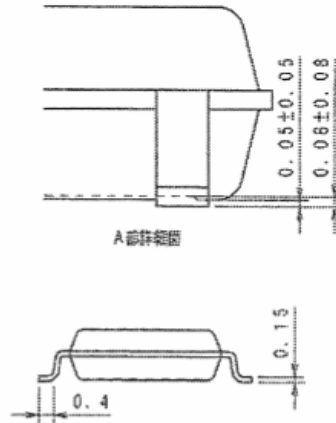
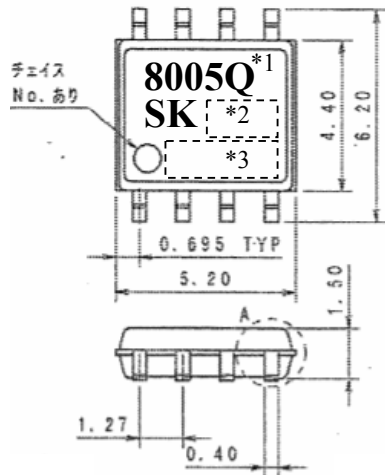

端子配列  
PIN Assignment

- 1.BS
- 2.IN
- 3.SW
- 4.GND
- 5.FB
- 6.COMP
- 7.EN
- 8.SS

\*1.品名標示

Type number

\*2.ロット番号(3桁)

Lot number (three digit)

第1文字 西暦年号下一桁

1<sup>st</sup> letter The last digit of year

第2文字 月

2<sup>nd</sup> letter Month

1~9月: アラビア数字

10月: O

11月: N

12月: D

(1 to 9 for Jan. to Sept.,

O for Oct. N for Nov. D for Dec.)

第3,4文字 製造週

3<sup>rd</sup> & 4<sup>th</sup> letter week

01~05: アラビア数字

Arabic Numerical

\*3.管理番号(4桁)

Control number (four digit)

6-2外觀

Appearance

本体は、汚れ、傷、亀裂等なく綺麗であること。

The body shall be clean and shall not bear any stain, rust or flaw.

6-3標示

Marking

標示は本体に、品名及びロット番号を明瞭、かつ容易に消えぬようレーザーで捺印すること。

The type number and lot number shall be marked on the body by leaser which shall not be unreadable easily.

TOSHIBA CMOS Digital Integrated Circuit Silicon Monolithic

# TC74HC4094AP, TC74HC4094AF, TC74HC4094AFN

## 8-Bit Shift and Store Register (3-state)

The TC74HC4094A is a high speed CMOS 8-BIT SHIFT AND STROBE REGISTER fabricated with silicon gate C<sup>2</sup>MOS technology.

It achieves the high speed operation similar to equivalent LSTTL while maintaining the CMOS low power dissipation.

It consists of an 8-bit shift register and an 8-bit latch with 3-state output buffers. Data is shifted serially through the shift register on the positive going transition of the CK input. The output of the last stage (Q<sub>s</sub>) can be used to cascade several devices. Data on the Q<sub>s</sub> output is transferred to a second output (Q's) on the following negative transition of the CK input. The data in each stage of the shift register is provided to a corresponding latch, on the negative going transition of the STROBE input. When STROBE is held high, data propagates through the latch to a 3-state output buffer. This buffer is enabled when OUTPUT ENABLE input is set high.

All inputs are equipped with protection circuits against static discharge or transient excess voltage.

### Features

- High speed:  $f_{max} = 73 \text{ MHz (typ.)}$  at  $V_{CC} = 5 \text{ V}$
- Low power dissipation:  $I_{CC} = 4 \mu\text{A (max)}$  at  $T_a = 25^\circ\text{C}$
- High noise immunity:  $V_{NIH} = V_{NIL} = 28\% V_{CC} \text{ (min)}$
- Output drive capability: 10 LSTTL loads
- Symmetrical output impedance:  $|I_{OH}| = I_{OL} = 4 \text{ mA (min)}$
- Balanced propagation delays:  $t_{pLH} \approx t_{pHL}$
- Wide operating voltage range:  $V_{CC} \text{ (opr)} = 2 \text{ to } 6 \text{ V}$
- Pin and function compatible with 4094B

### Pin Assignment

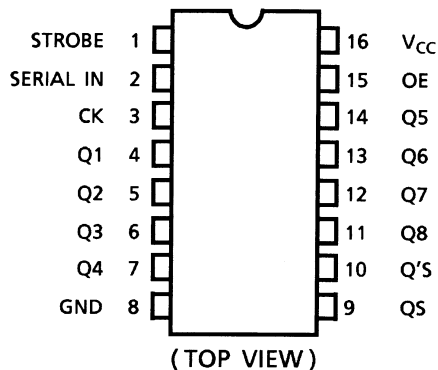

Note: xxxFN (JEDEC SOP) is not available in Japan.

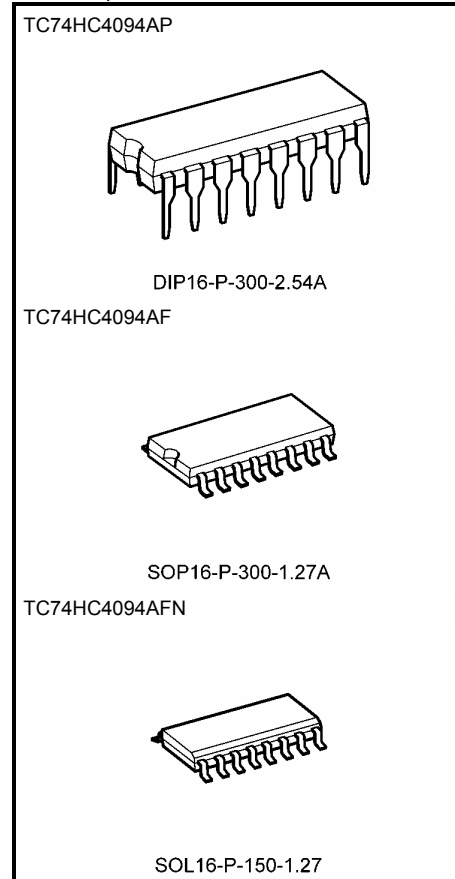

Weight	
DIP16-P-300-2.54A	: 1.00 g (typ.)
SOP16-P-300-1.27A	: 0.18 g (typ.)
SOL16-P-150-1.27	: 0.13 g (typ.)

**PIN ASSIGNMENT**

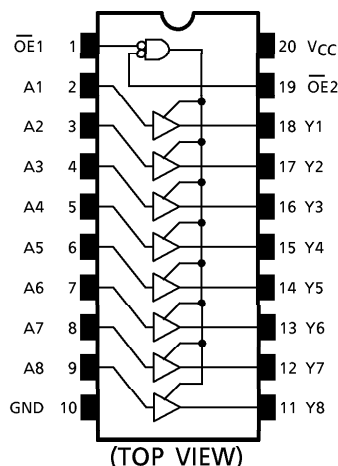

**IEC LOGIC SYMBOL**

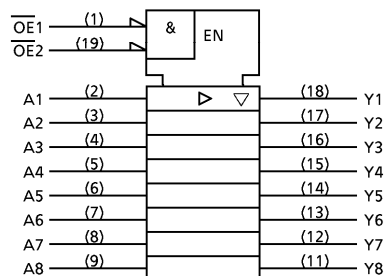

**TRUTH TABLE**

INPUTS			OUTPUTS
OE1	OE2	An	
H	X	X	Z
X	H	X	Z
L	L	H	H
L	L	L	L

X : Don't Care  
Z : High Impedance

**MAXIMUM RATINGS**

PARAMETER	SYMBOL	RATING	UNIT
Supply Voltage Range	V <sub>CC</sub>	- 0.5~7.0	V
DC Input Voltage	V <sub>IN</sub>	- 0.5~7.0	V
DC Output Voltage	V <sub>OUT</sub>	- 0.5~7.0 (Note 1)	V
		- 0.5~V <sub>CC</sub> + 0.5 (Note 2)	
Input Diode Current	I <sub>IK</sub>	- 50	mA
Output Diode Current	I <sub>OK</sub>	± 50 (Note 3)	mA
DC Output Current	I <sub>OUT</sub>	± 50	mA
Power Dissipation	P <sub>D</sub>	180	mW
DC V <sub>CC</sub> /Ground Current	I <sub>CC</sub> /I <sub>GND</sub>	± 100	mA
Storage Temperature	T <sub>stg</sub>	- 65~150	°C

(Note 1) Output in Off-State  
(Note 2) High or Low State. I<sub>OUT</sub> absolute maximum rating must be observed.  
(Note 3) V<sub>OUT</sub><GND, V<sub>OUT</sub>>V<sub>CC</sub>

961001EBA2'

● The products described in this document are subject to foreign exchange and foreign trade control laws.  
● The information contained herein is presented only as a guide for the applications of our products. No responsibility is assumed by TOSHIBA CORPORATION for any infringements of intellectual property or other rights of the third parties which may result from its use. No license is granted by implication or otherwise under any intellectual property or other rights of TOSHIBA CORPORATION or others.  
● The information contained herein is subject to change without notice.

TOSHIBA CMOS DIGITAL INTEGRATED CIRCUIT SILICON MONOLITHIC

# TC74VHC157F, TC74VHC157FN, TC74VHC157FT

## QUAD 2-CHANNEL MULTIPLEXER

The TC74VHC157 is an advanced high speed CMOS QUAD 2-CHANNEL MULTIPLEXER fabricated with silicon gate C<sup>2</sup>MOS technology.

It achieves the high speed operation similar to equivalent Bipolar Schottky TTL while maintaining the CMOS low power dissipation.

It consists of four 2-input digital multiplexers with common select and strobe inputs.

When the STROBE input is held "H" level, selection of data is inhibited and all the outputs become "L" level.

The SELECT decoding determines whether the A or B inputs get routed to their corresponding Y outputs.

An Input protection circuit ensures that 0 to 5.5V can be applied to the input pins without regard to the supply voltage. This device can be used to interface 5V to 3V systems and on two supply systems such as battery back up. This circuit prevents device destruction due to mismatched supply and input voltages.

### FEATURES :

- High Speed..... $t_{pd} = 4.1ns(typ.)$  at  $V_{CC} = 5V$
- Low Power Dissipation..... $I_{CC} = 4\mu A(Max.)$  at  $T_a = 25^{\circ}C$
- High Noise Immunity..... $V_{NIH} = V_{NIL} = 28\% V_{CC} (Min.)$
- Power Down Protection is provided on all inputs.
- Balanced Propagation Delays..... $t_{pLH} \approx t_{pHL}$
- Wide Operating Voltage Range..... $V_{CC} (opr) = 2V \sim 5.5V$
- Low Noise ..... $V_{OLP} = 0.8V (Max.)$
- Pin and Function Compatible with 74ALS157

### TRUTH TABLE

INPUTS				OUTPUT
$\overline{ST}$	SELECT	A	B	
H	X	X	X	L
L	L	L	X	L
L	L	H	X	H
L	H	X	L	L
L	H	X	H	H

X : Don't Care

(Note) The JEDEC SOP (FN) is not available in Japan.

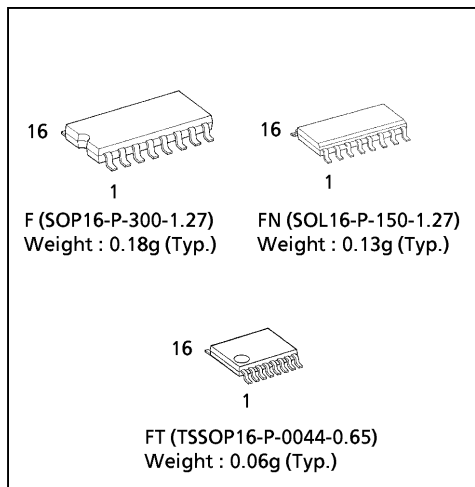

### PIN ASSIGNMENT

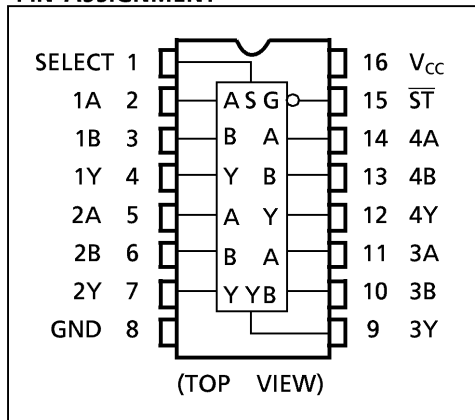

### IEC LOGIC SYMBOL

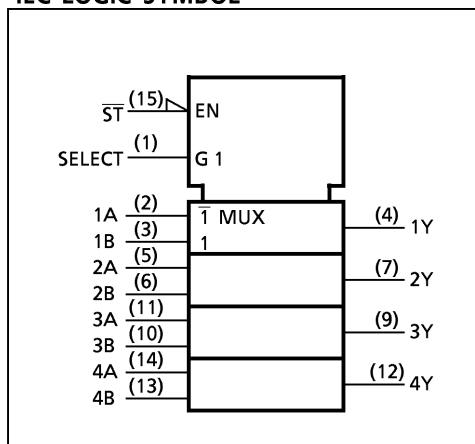

980910EBA2

● TOSHIBA is continually working to improve the quality and the reliability of its products. Nevertheless, semiconductor devices in general can malfunction or fail due to their inherent electrical sensitivity and vulnerability to physical stress. It is the responsibility of the buyer, when utilizing TOSHIBA products, to observe standards of safety, and to avoid situations in which a malfunction or failure of a TOSHIBA product could cause loss of human life, bodily injury or damage to property. In developing your designs, please ensure that TOSHIBA products are used within specified operating ranges as set forth in the most recent products specifications. Also, please keep in mind the precautions and conditions set forth in the TOSHIBA Semiconductor Reliability Handbook.

## 2. Pin Assignment and Functions

The assignment of input/output pins for the TMP92FD28, their names and functions are as follows:

### 2.1 Pin Assignment Diagram

Figure 2.1.1 shows the pin assignment of the TMP92FD28FG.

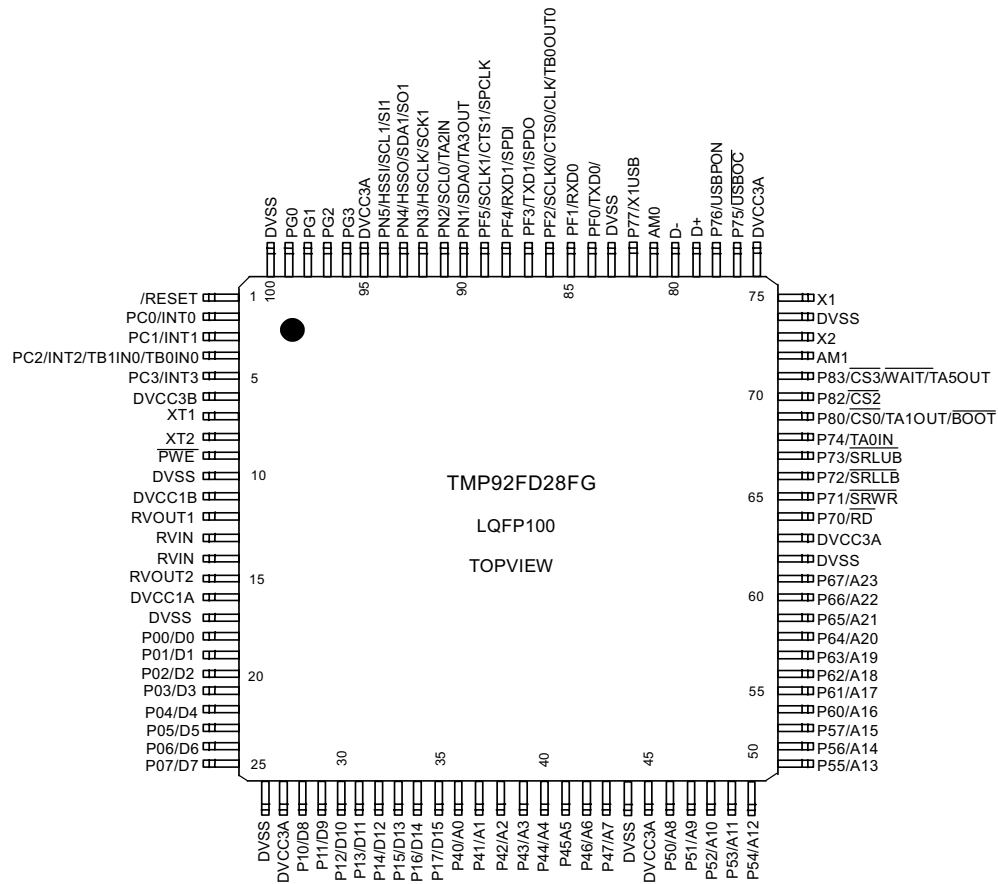

Figure 2.1.1 Pin Assignment Diagram (100-pin LQFP)

## 2.2 Pin Names and Functions

The following table shows the names and functions of the input/output pins.

Table 2.2.1 Pin Names and Functions (1/3)

Pin name	Number of Pin	I/O	Function
P00 to P07 D0 to D7	8	I/O I/O	Port 0: I/O port Input or output specifiable in units of bits Data: Data bus 0 to 7
P10 to P17 D8 to D15	8	I/O I/O	Port 1: I/O port Input or output specifiable in units of bits Data: Data bus 8 to 15
P40 to P47 A0 to A7	8	I/O Output	Port 4: I/O port Input or output specifiable in units of bits Address: Address bus 0 to 7
P50 to P57 A8 to A15	8	I/O Output	Port 5: I/O port Input or output specifiable in units of bits Address: Address bus 8 to 15
P60 to P67 A16 to A23	8	I/O Output	Port 6: I/O port Input or output specifiable in units of bits Address: Address bus 16 to 23
P70 $\overline{RD}$	1	I/O Output	Port 70: I/O port (Schmitt input, with pull-up register) Read: Outputs strobe signal for read external memory.
P71 $\overline{SRWR}$	1	I/O Output	Port 71: I/O port (Schmitt input, with pull-up register) Write enable for SRAM: Strobe signal for writing data.
P72 $\overline{SRLLB}$	1	I/O Output	Port 72: I/O port (Schmitt input, with pull-up register) Data enable for SRAM on pins D0 to D7
P73 $\overline{SRLUB}$	1	I/O Output	Port 73: I/O port (Schmitt input, with pull-up register) Data enable for SRAM on pins D8 to D15
P74 TA0IN	1	I/O Input	Port 74: Input port (Schmitt input) 8-bit timer 0 input: Input pin of 8-bit timer TMRA0
P75 $\overline{USBOC}$	1	I/O Input	Port 75: I/O port (Schmitt input) USBOC Input
P76 USBPON	1	I/O Output	Port 76: I/O port (Schmitt input) USBPON Output
P77 X1USB	1	I/O Input	Port 77: I/O port 48MHz Clock Input for USB Host Controller
P80 $\overline{CS0}$ TA1OUT BOOT	1	Output Output Output Input	Port 80: Output port Chip select 0: Outputs "Low" when address is within specified address area 8-bit timer 1 Output: Output pin of 8-bit timer TMRA0 or TMRA1 This pin sets single boot mode (only during reset).
P82 $\overline{CS2}$	1	Output Output	Port 82: Output port Chip select 2: Outputs "Low" when address is within specified address area
P83 $\overline{CS3}$ TA5OUT $\overline{WAIT}$	1	I/O Output Output Input	Port 83: I/O port Chip select 3: Outputs "Low" when address is within specified address area 8-bit timer 5 Output: Output pin of 8-bit timer TMRA4 or TMRA5 Wait: Signal used to request CPU bus wait
PC0 INT0	1	Input Input	Port C0: Input port (Schmitt input) Interrupt request pin0 : Interrupt request pin with programmable level/rising/falling edge
PC1 INT1	1	Input Input	Port C1: Input port (Schmitt input) Interrupt request pin 1 : Interrupt request pin with programmable level/rising/falling edge
PC2 INT2 TB0IN0 TB1IN0	1	Input Input Input Input	Port C2: Input port (Schmitt input) Interrupt request pin 2 : Interrupt request pin with programmable level/rising/falling edge 16-bit timer 0 input 0: Input of count/capture trigger in 16-bit timer TMRB0 16-bit timer 1 input 0: Input of count/capture trigger in 16-bit timer TMRB1
PC3 INT3	1	Input Input	Port C3: Input port (Schmitt input) Interrupt request pin 3 : Interrupt request pin with programmable level/rising/falling edge



**TOSHIBA**

TMP92FD28

Table 2.2.1 Pin Names and Functions (2/3)

Pin name	Number of Pin	I/O	Function
PF0 TXD0	1	I/O Output	Port F0: I/O port (Schmitt input) Serial 0 send data: Open drain output programmable
PF1 RXD0	1	I/O Input	Port F1: I/O port (Schmitt input) Serial 0 receive data
PF2 SCLK0 CTS0 CLK TB0OUT0	1	I/O I/O Input Output Output	Port F2: I/O port (Schmitt input) Serial 0 clock I/O Serial 0 data send enable (Clear to send) Clock: System Clock output 16-bit timer 0 output 0: Output pin of 16-bit timer TMRB0
PF3 TXD1 SPDO	1	I/O Output Output	Port F3: I/O port (Schmitt input) Serial 1 send data: Open drain output programmable SPI Data output
PF4 RXD1 SPDI	1	I/O Input Input	Port F4: I/O port (Schmitt input) Serial 1 receive data SPI Data input
PF5 SCLK1 CTS1 SPCLK	1	I/O I/O Input Output	Port F5: I/O port (Schmitt input) Serial 1 clock I/O Serial 1 data send enable (Clear to send) SPI Clock output
PG0 to PG3 KI0 to KI3	4	Input Input	Port G: Input port (Schmitt input) Key input 0 to 3: Pin used of key-on wakeup 0 to 3
PN1 SDA0 TA3OUT	1	I/O I/O Output	Port N1: I/O port (Schmitt input, Open drain output) Serial bus interface 0 send/receive data at I <sup>2</sup> C mode 8-bit timer 3 Output: Output pin of 8-bit timer TMRA2 or TMRA3
PN2 SCL0 TA2IN	1	I/O I/O Input	Port N2: I/O port (Schmitt input, Open drain output) Serial bus interface 0 clock I/O data at I <sup>2</sup> C mode 8-bit timer 2 input: Input pin of 8-bit timer TMRA2
PN3 SCK1 HSCLK	1	I/O I/O Output	Port N3: I/O port (Schmitt input) Serial bus interface 1 clock I/O data at SIO mode HSIO Clock output
PN4 SDA1 SO1 HSSO	1	I/O I/O Output Output	Port N4: I/O port (Schmitt input, Open drain output) Serial bus interface 1 send/receive data at I <sup>2</sup> C mode Serial bus interface 1 send data at SIO mode HSIO Data output
PN5 SCL1 SI1 HSSI	1	I/O I/O Input Input	Port N5: I/O port (Schmitt input, Open drain output) Serial bus interface 1 clock I/O data at I <sup>2</sup> C mode Serial bus interface 1 receive data at SIO mode HSIO Data input

Table 2.2.1 Pin Names and Functions (3/3)

Pin name	Number of Pin	I/O	Function
X1 / X2	2	I/O	High-frequency oscillator connection I/O pins
XT1 / XT2	2	I/O	Low-frequency oscillator circuit connection pin.
AM0, AM1	2	Input	Operation mode: Fixed to AM1 = "1" and AM0 = "1"
RESET	1	Input	Reset: Initializes TMP92FD28 (Schmitt input, with pull-up register)
PWE	1	Output	External power supply control output: Pin to control ON/OFF of external power supply. In stand-by mode, outputs "L" level. In other than stand-by mode, outputs "H" level.
D+, D-	2	I/O	Data pin connected to USB. In case USB is not used, connect both pins to pull-up(DVCC3A) or pull-down resistor for protect current flows it.
RVIN	2	Input	Power supply pin for Internal Regulator
RVOUT1, RVOUT2	2	Output	1.5V output from Internal Regulator (Only Mask ROM Version)
DVCC3A	5	—	Power supply pin for peripheral I/O-A (Connect all DVCC3A pins to power supply pin.)
DVCC3B	1	—	Power supply pin for peripheral I/O-B (Connect all DVCC3B pins to power supply pin.)
DVCC1A	1	—	Power supply pin for internal logic-A. (Only Mask ROM Version)
DVCC1B	1	—	Power supply pin for internal logic-B. (Only Mask ROM Version)
DVSS	8	—	GND pins (0 V) (All DVSS pins should be connected with GND(0V))

Note1) In Flash version, the regulator does not built. But supply voltage as DVCC3 power because RVIN pins are used power supply pins.

Note2) In Flash version, voltage does not output from RVOUT1 and RVOUT2.

Note3) When using MASK version in combination with Flash version, connect RVOUT1 and DVCC1B, RVOUT2 and DVCC1A.

When using only Flash version, connect DVCC1A and DVCC1B, RVOUT1 and RVOUT2 to VDD3

253.0mm

181.0mm

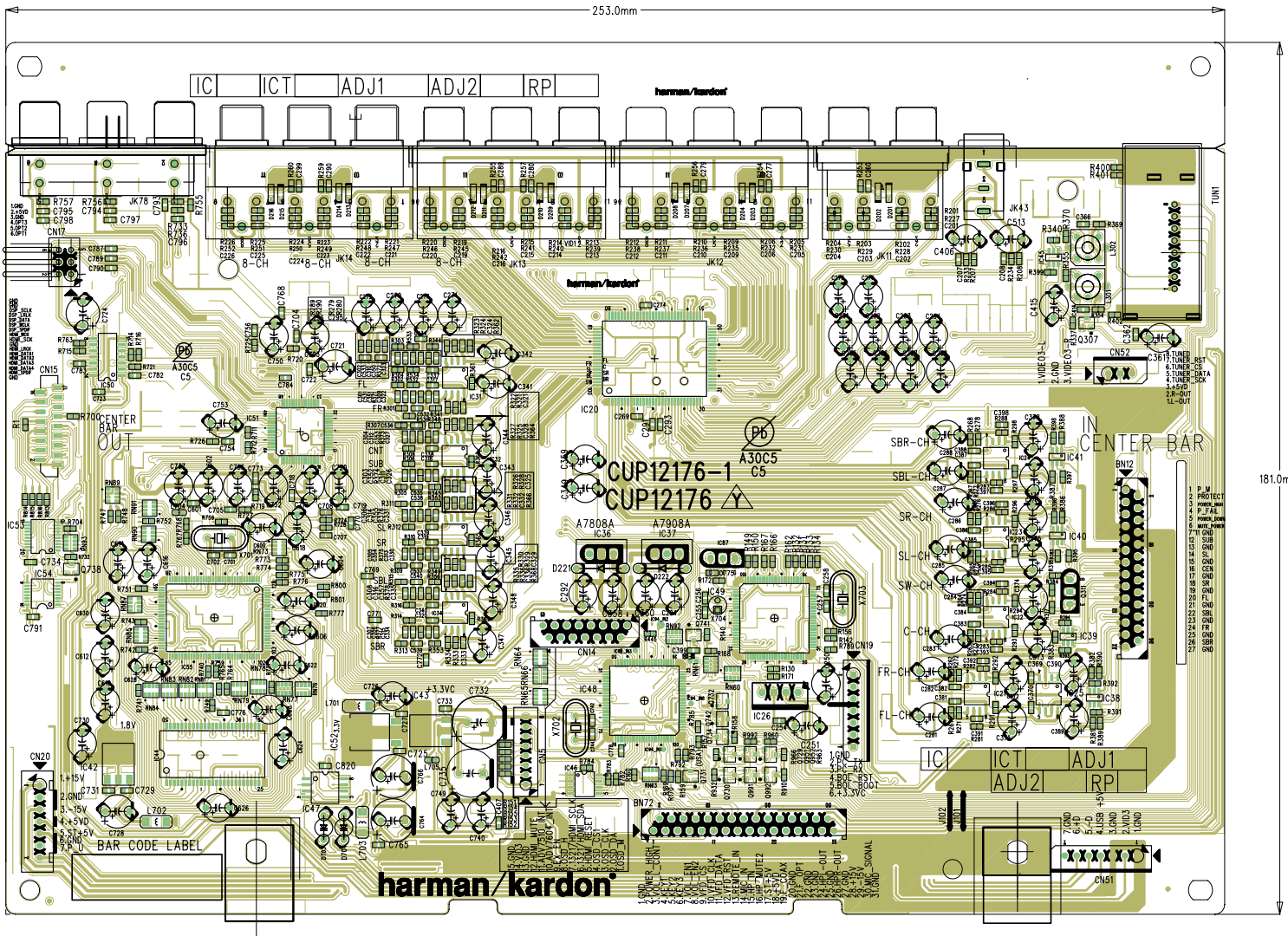

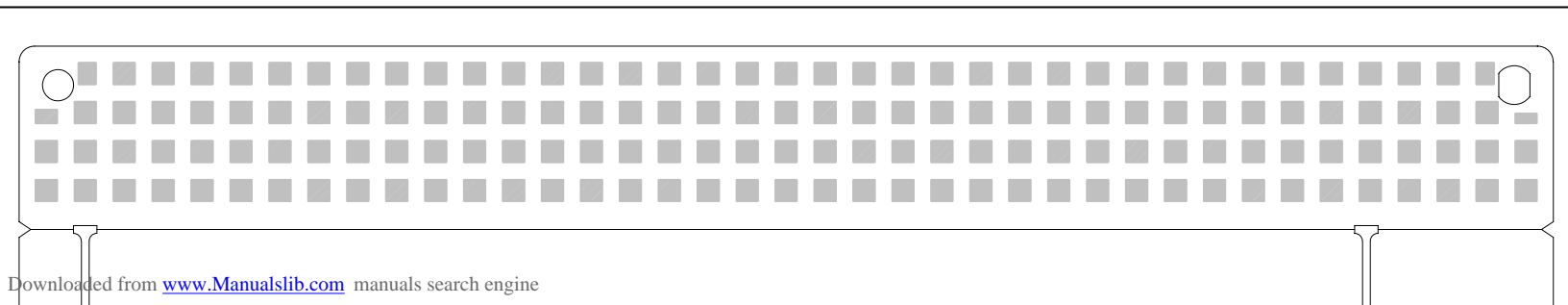

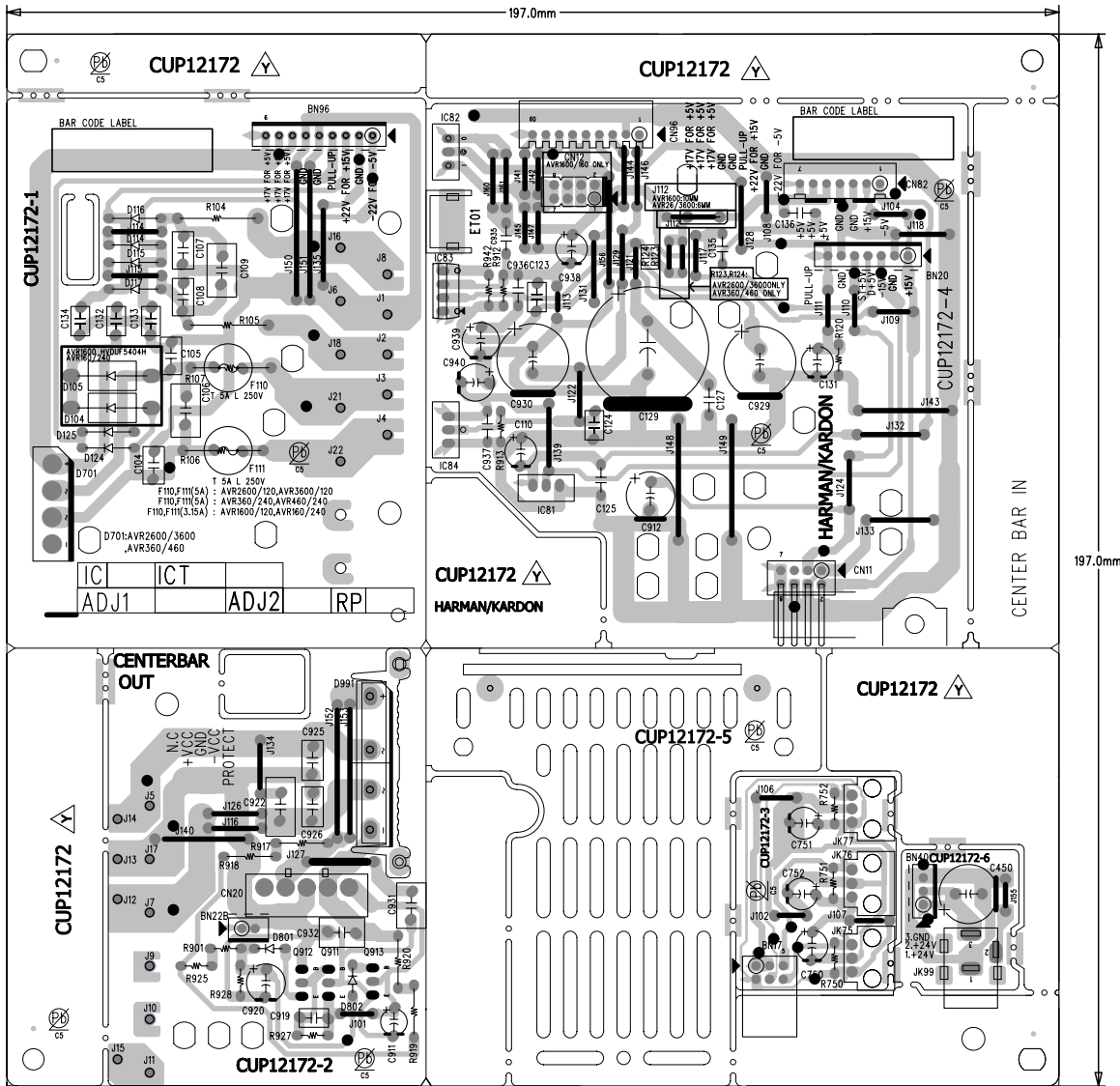

AVRx60\_MAIN\_MP2\_CUP12170X\_A

DIPPING  
CUP12170

IC	ICT	ADJ1	ADJ2	RP
----	-----	------	------	----

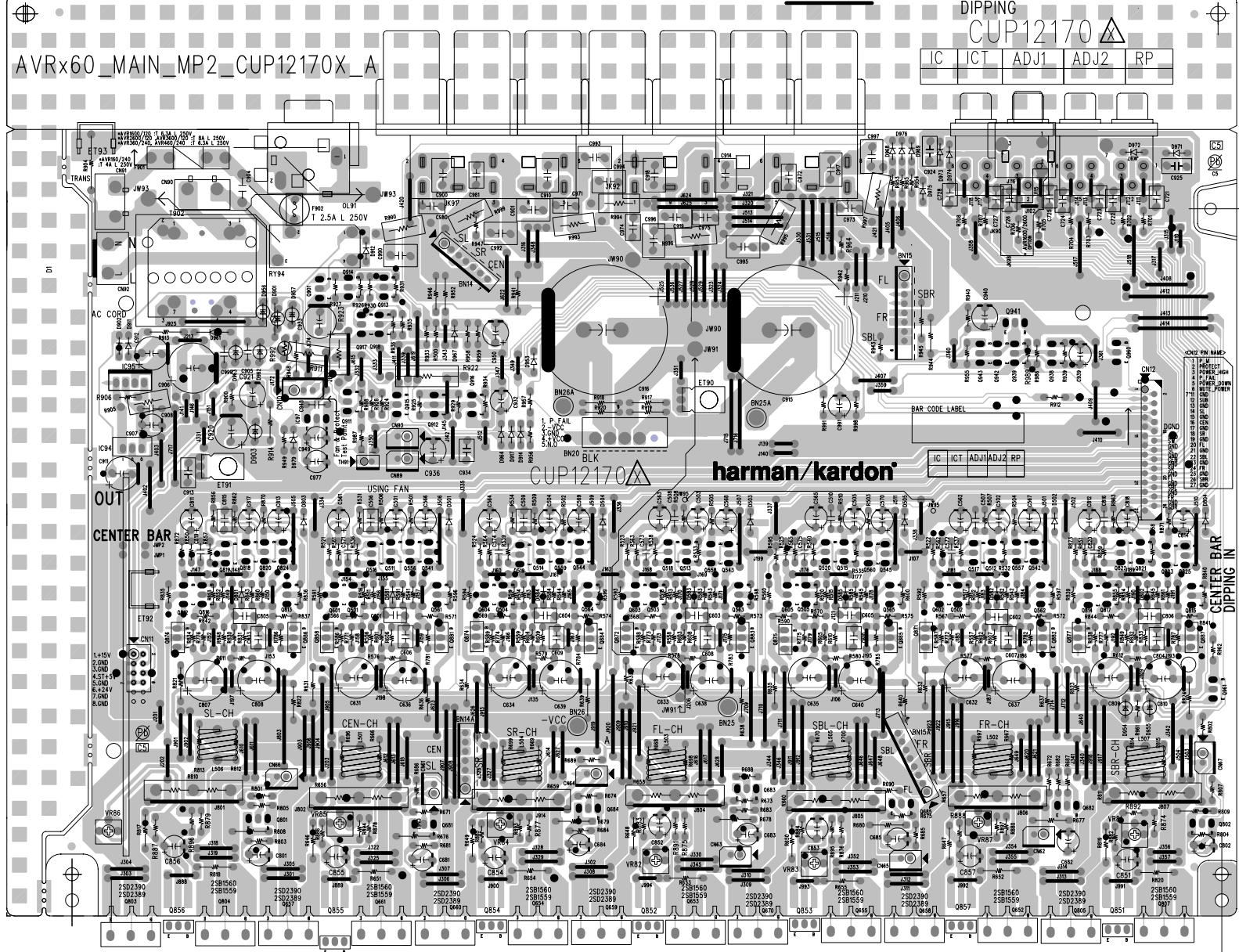

7.5mm Add : J888,J889,J900,J992,J991  
 6.0mm Add : J994,J993  
 10.0mm Add : J145



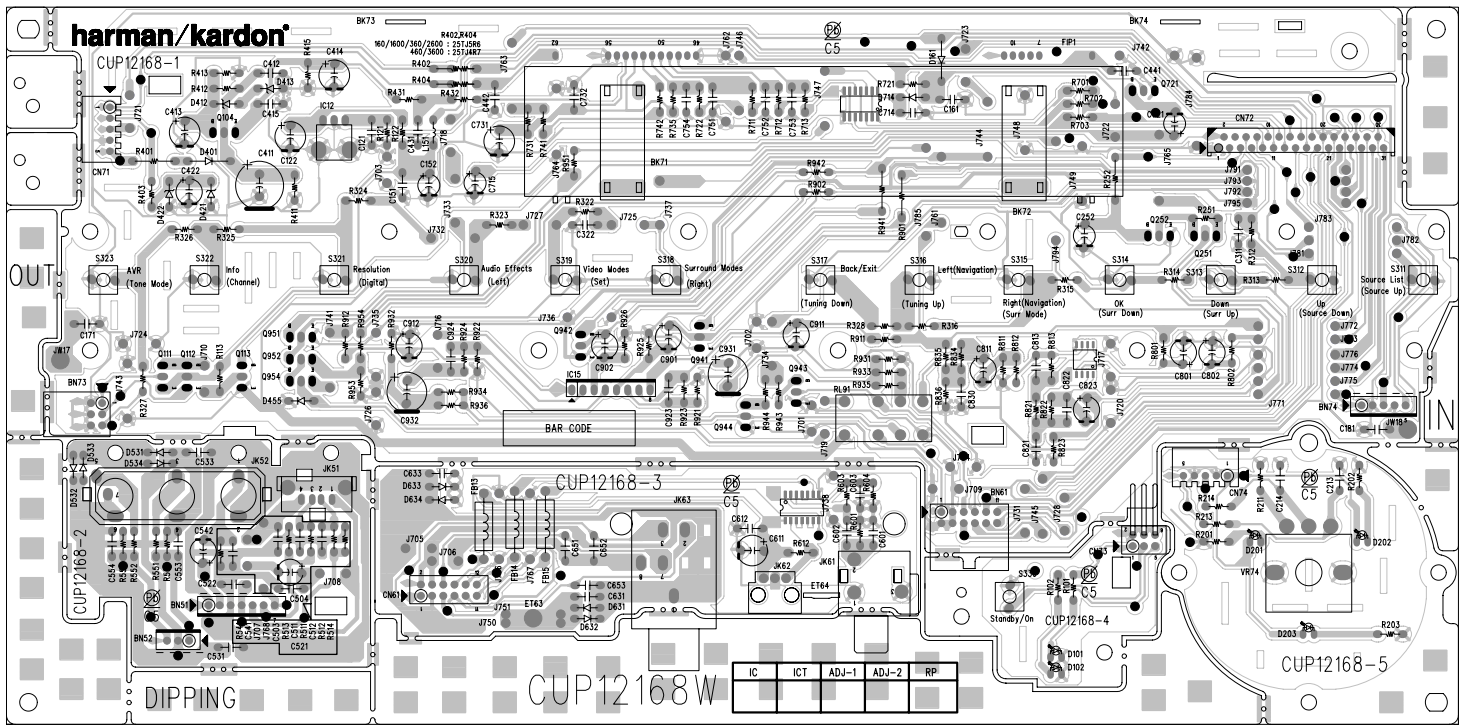





harman/kardon

AVR 160/230 Service Manual

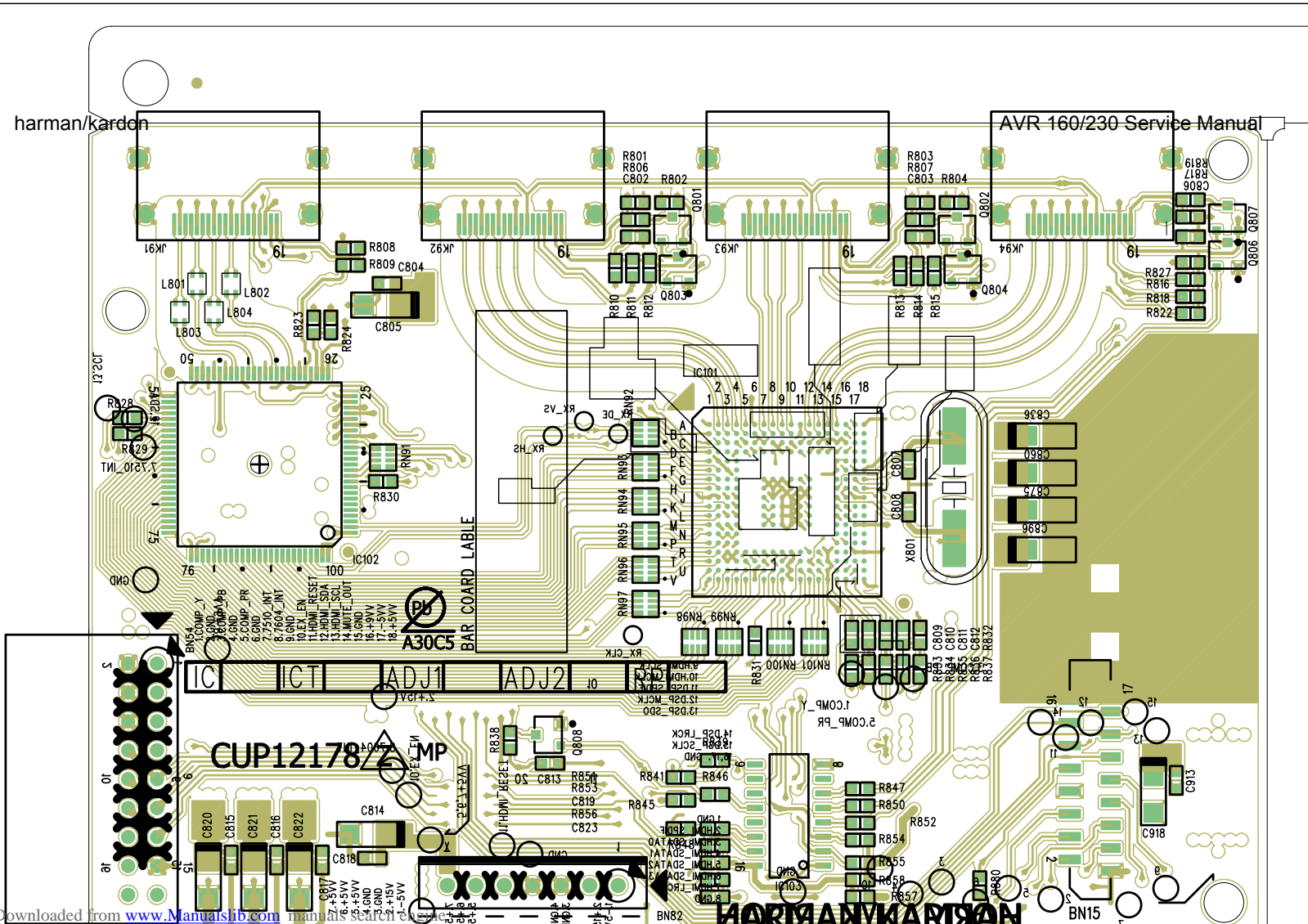

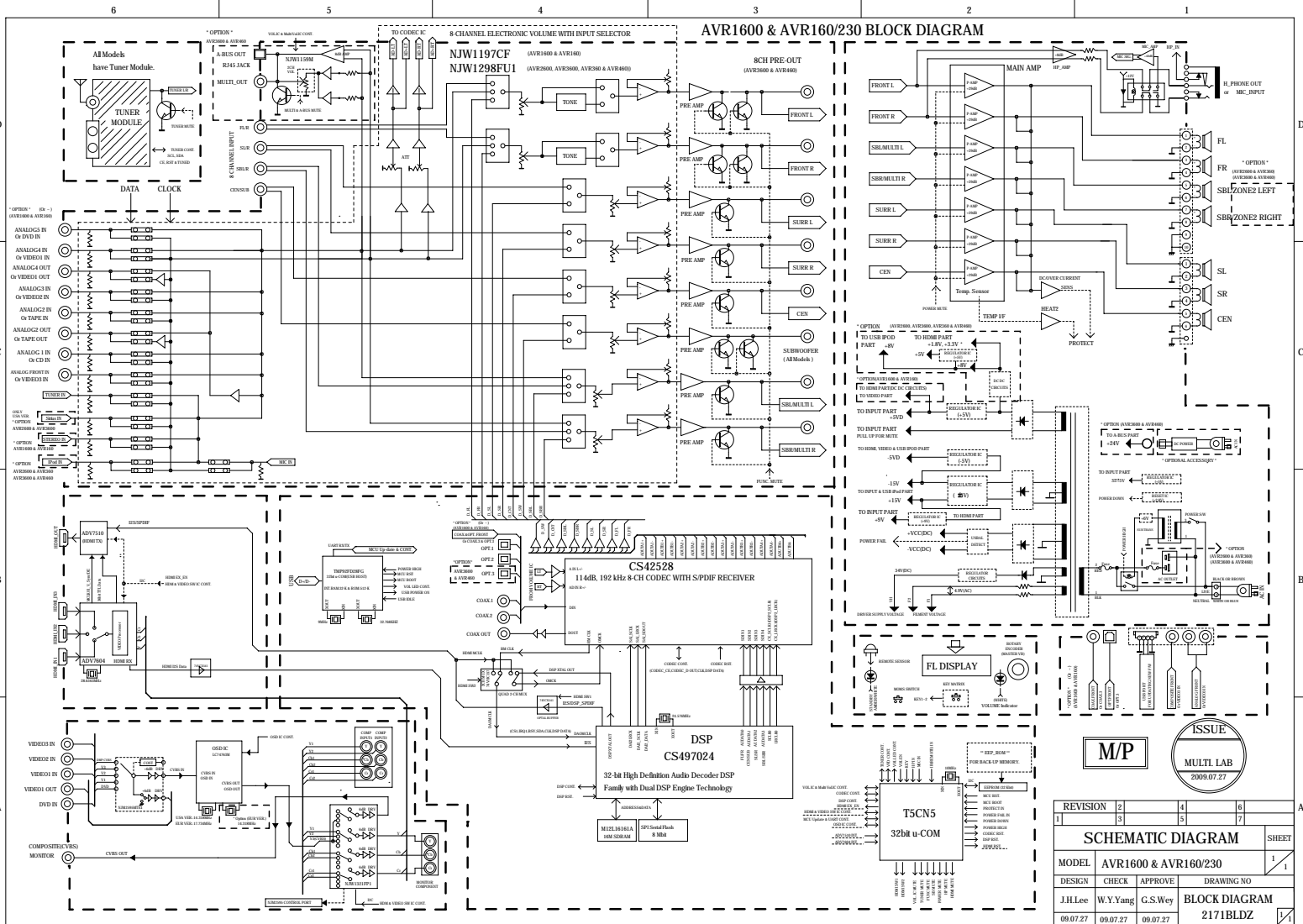

REVISION		2	6
1		3	7
<b>SCHEMATIC DIAGRAM</b>			
MODEL		AVR1600 & AVR160/230	
DESIGN	CHECK	APPROVE	DRAWING NO
J.H.Lee	W.Y.Yang	G.S.Wey	BLOCK DIAGRAM
09.07.27	09.07.27	09.07.27	2171BLDZ

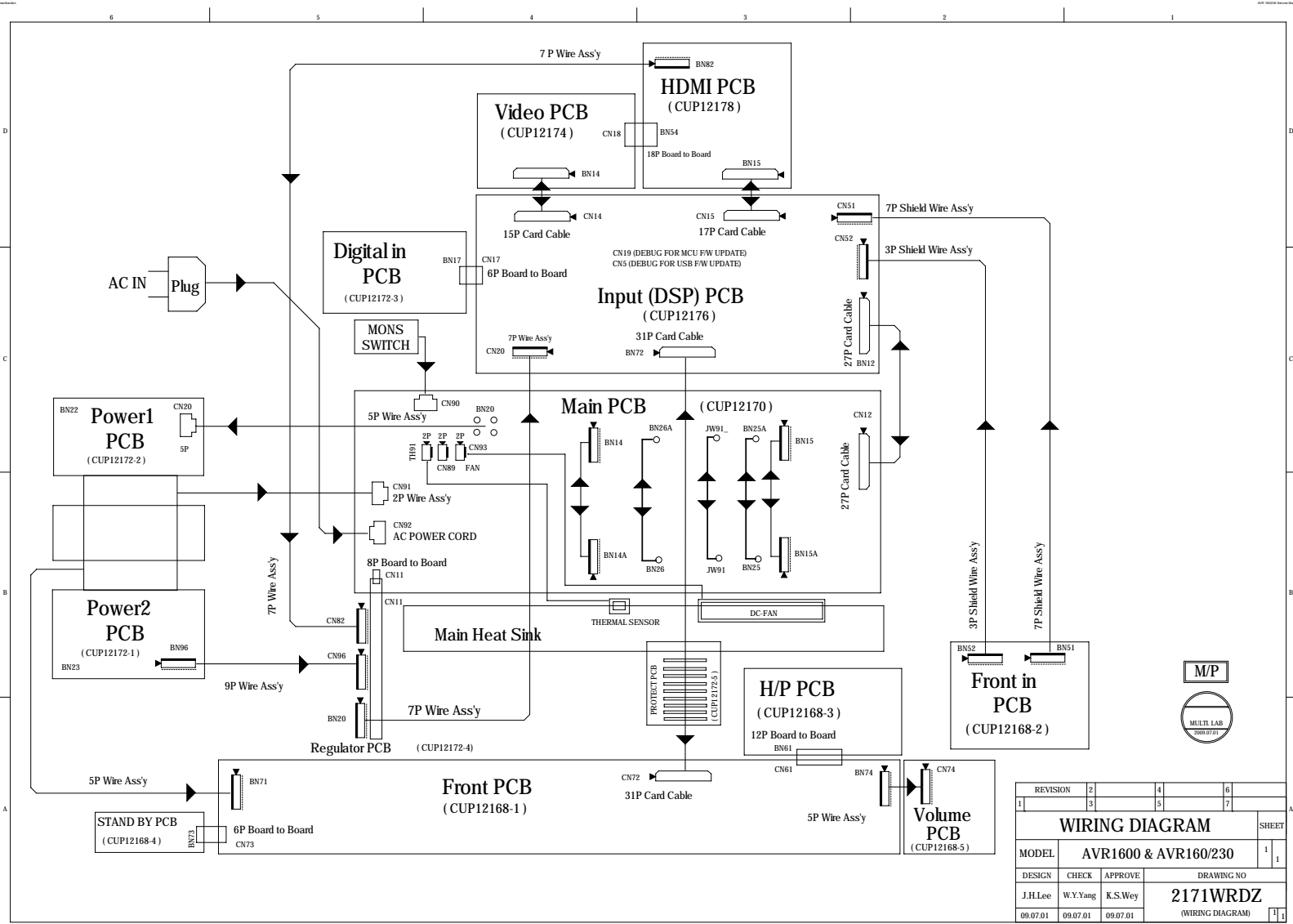

REVISION	2	4	6
1	3	5	7
<b>WIRING DIAGRAM</b>			
MODEL	AVR1600 & AVR160/230		
DESIGN	CHECK	APPROVE	DRAWING NO
J.H.Lee	W.Y.Yang	K.S.Wey	<b>2171WRDZ</b>
09.07.01	09.07.01	09.07.01	(WIRING DIAGRAM)

# AMPLIFIER SECTION BIAS ADJUSTMENT

**Measurement condition**

; No input signal or volume position is minimum.

**Standard value**

; Ideal current = 48mA (± 5%)

; Ideal DC Voltage = 25.92mV (± 5%)

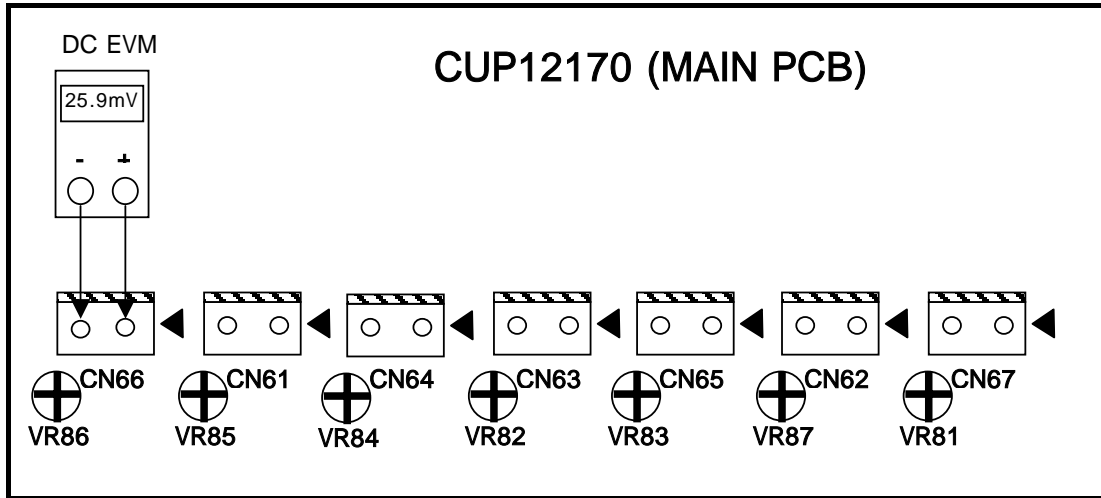

**DC VOLTMETER ; Connect to**

CN66(SL),CN61(CEN),CN64(SR),CN63(FL),CN65(SBL),CN62(FR),CN67(SBR)

NO.	Channel	Adjust for	Adjustment
1	Front Left	25.92mV (± 5%)	CN63
2	Front Right	25.92mV (± 5%)	CN62
3	Center	25.92mV (± 5%)	CN61
4	Surround Left	25.92mV (± 5%)	CN66
5	Surround Right	25.92mV (± 5%)	CN64
6	Surround Back Left	25.92mV (± 5%)	CN65
7	Surround Back Right	25.92mV (± 5%)	CN67

# CUP12170Z

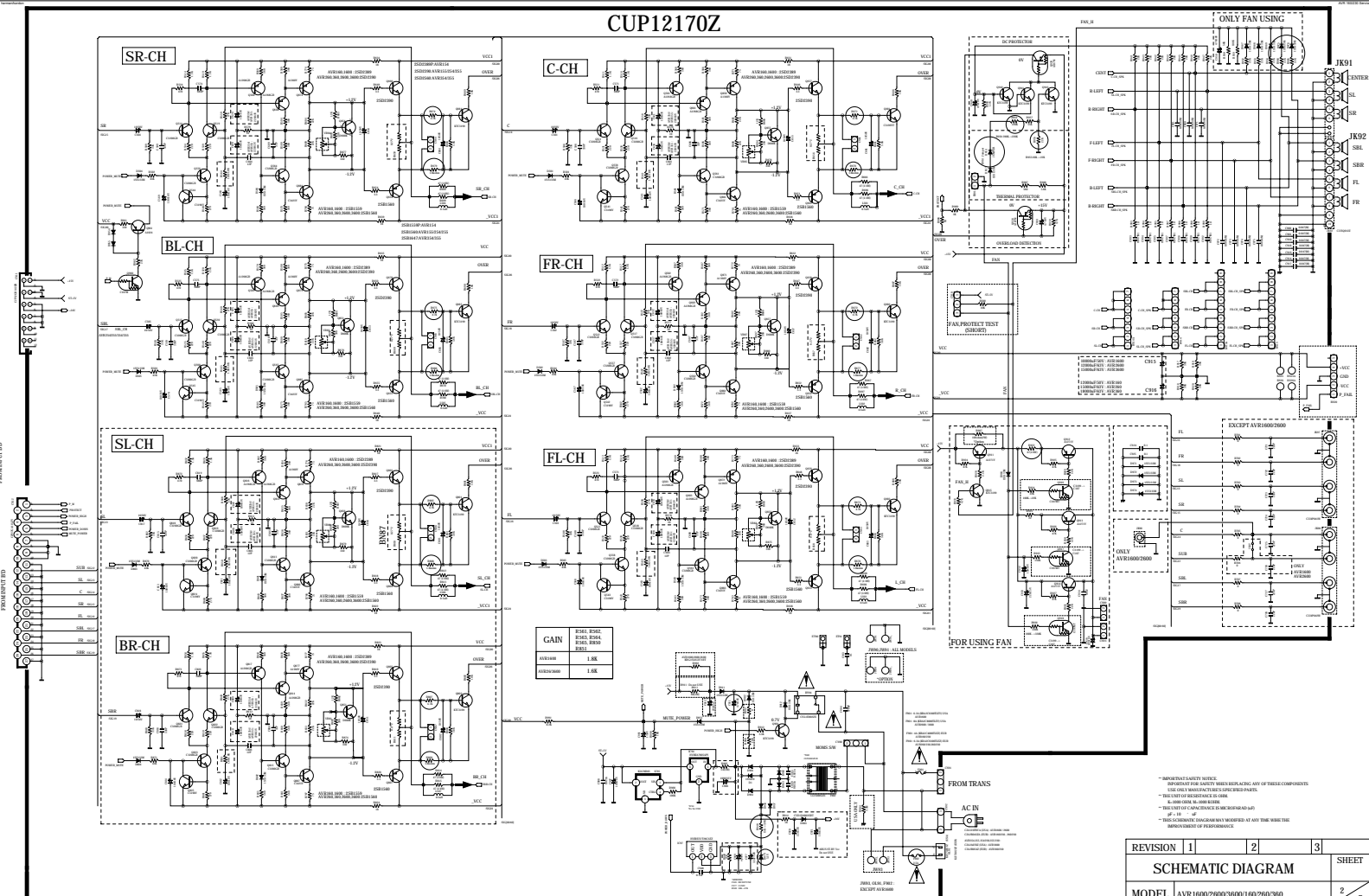

GAIN	WAVE RANGE
100000	0.1MHz
100000	0.1MHz
100000	0.1MHz

- IMPORTANT SAFETY NOTICE
- SPECIFIC FOR SAFETY WHEN USE AC/DC, ANY OF THESE COMPONENTS
- USE ONLY MANUFACTURER'S SPECIFIED PARTS
- THE TEST OF RESISTANCE IS 100MΩ
- 100MΩ (100kΩ) IS 100MΩ
- THE TEST OF CAPACITANCE IS 1000PF TO 100NF
- THIS SCHEMATIC DIAGRAM MAY BE ADDED AT ANY TIME WITH THE IMPROVEMENT OF PERFORMANCE

REVISION	1	2	3	SHEET
SCHEMATIC DIAGRAM				2
MODEL	AVR1600/2600/3600/160/260/360			7
DESIGN	CHECK	APPROVE	DRAWING NO	
C.B.LEE	W.Y.YANG	G.S.WEY	2170SCLZ	
07.08.23			(MAIN)	



6 5 4 3 2 1

D  
C  
B  
A

# CUP12167Z

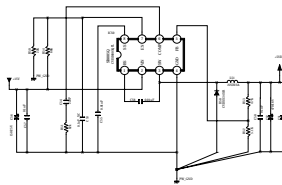
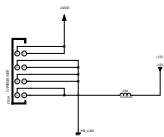

DC/DC REGULATOR

LPP



REVISION	2	4	6
1	3	5	7
<b>SCHEMATIC DIAGRAM</b>			SHEET
MODEL	<b>AVR1600</b>		5 / 5
DESIGN	CHECK	APPROVE	DRAWING NO
S. KIM	W.Y YANG	G.S WEY	<b>CUP12167Z</b>
09.02.04	09.02.04	09.02.04	<b>DC/DC REGULATOR</b>



# CUP12174Y

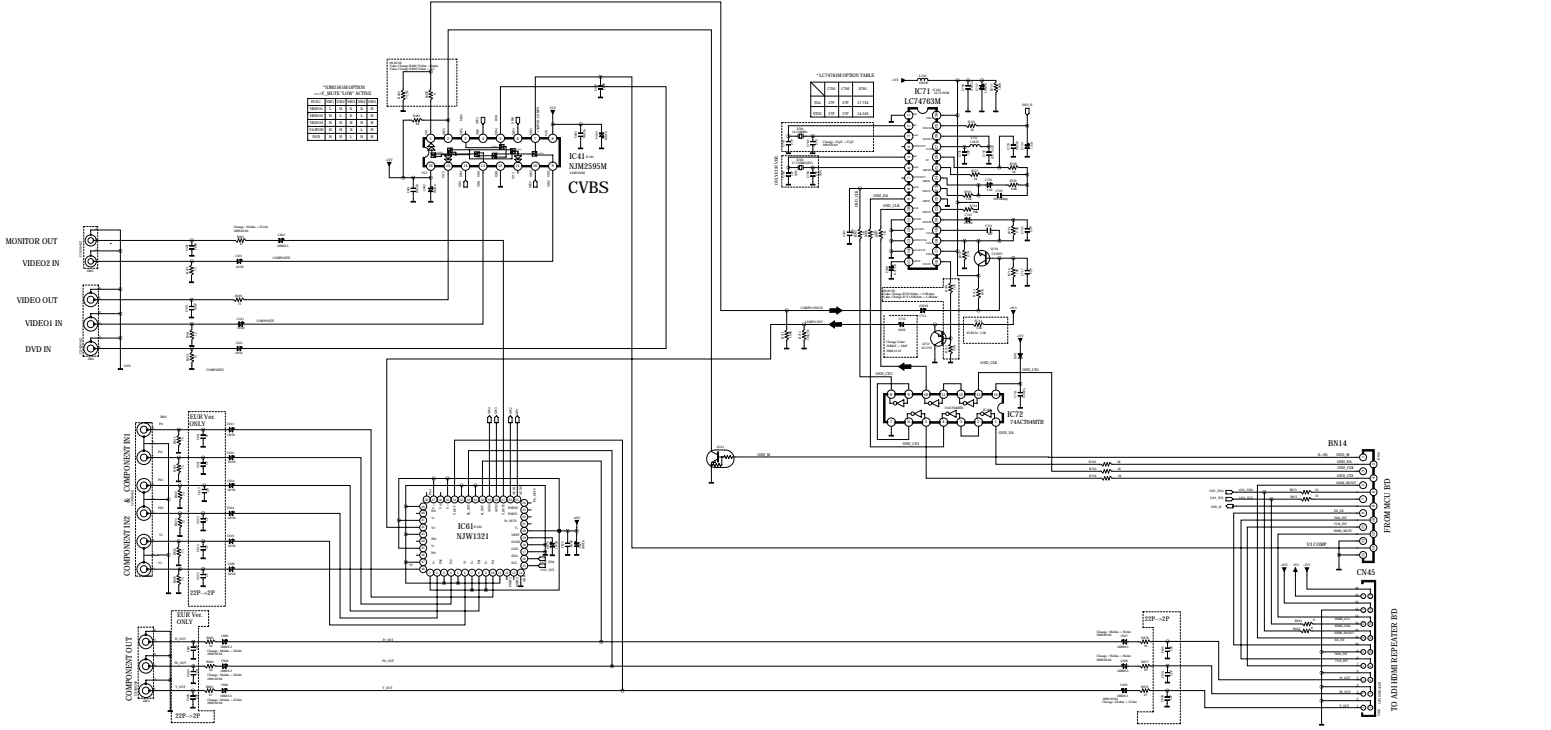

VIDEO SIGNAL OPTION  
- 4 PIN VIDEO IN/OUT

Pin	Signal	Option
1	CVBS	Standard
2	CVBS	Standard
3	CVBS	Standard
4	CVBS	Standard

LCT SIGNAL OPTION TABLE

Pin	Signal	Option
1	LCT	Standard
2	LCT	Standard
3	LCT	Standard
4	LCT	Standard

BY WELT SYSTEM

SERVO MOTOR OF DC SERVO MOTOR (NMW021)

Pin	Signal	Option
1	CVBS	Standard
2	CVBS	Standard
3	CVBS	Standard
4	CVBS	Standard

CONTROL SIGNALS RANGE

Pin	Signal	Option
1	CVBS	Standard
2	CVBS	Standard
3	CVBS	Standard
4	CVBS	Standard

AVR1600 SIGNALS

Pin	Signal	Option
1	CVBS	Standard
2	CVBS	Standard
3	CVBS	Standard
4	CVBS	Standard

REVISION		2	4	6
1	3	5	7	
<b>SCHEMATIC DIAGRAM</b>				
MODEL				AVR1600
DESIGN				S.K
CHECK				W.Y.Y
APPROVE				K.S.W
DRAWING NO				CUP12174
				(VIDEO)
				1/1



< TRANS PCB 1 >

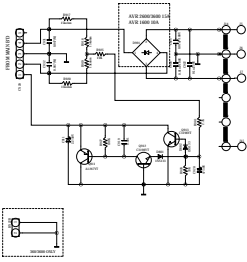

< TRANS PCB 2 >

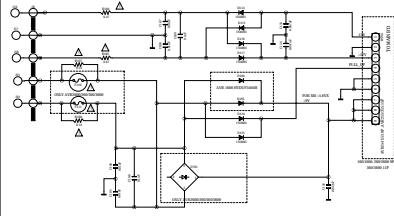

CUP1207-3

< OPTICAL PCB >

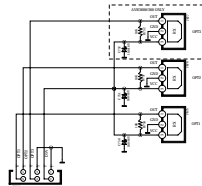

< REGULATOR PCB >

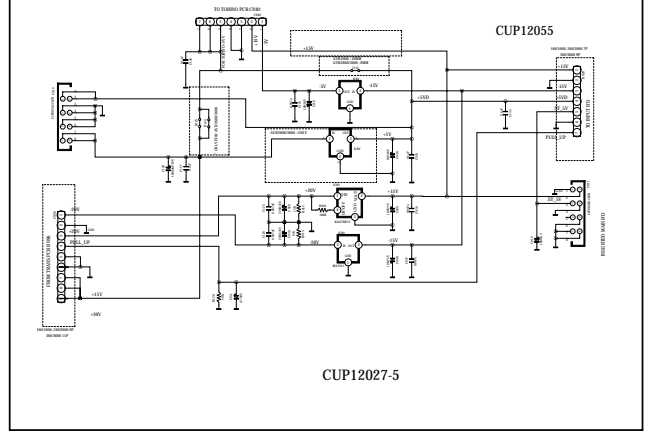

CUP1207-5

LPP



REVISION	2	4	6	
1	3	5	7	
<b>SCHEMATIC DIAGRAM</b>				SHEET
MODEL	AVR x600/x60			1 / 1
DESIGN	CHECK	APPROVE	DRAWING NO	
J.T.B	Y.Y.W	K.S.W	<b>CUP12xxxY</b>	
08.02.11			(POWER)	

# CUP12168\*

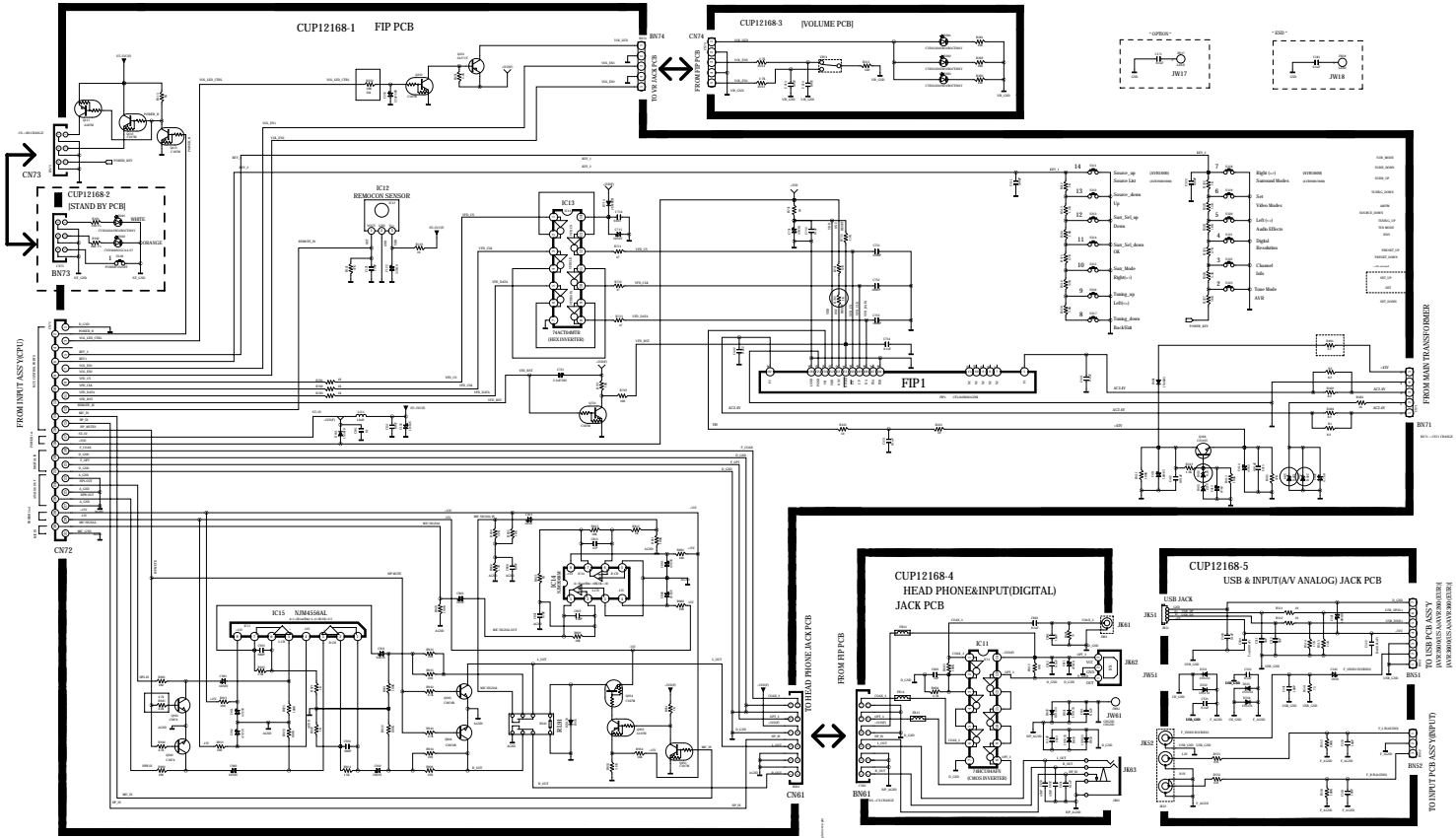

REVISION	2	4	6
1	3	5	7
<b>SCHEMATIC DIAGRAM</b>			
MODEL	AVR1600,AVR2600,AVR3600		
DESIGN	CHECK	APPROVED	DRAWING NO
J.H.L	W.Y.Y	G.S.W	2168SCLZ
09.02.18	09.02.18	09.02.18	(FRONT)



# CUP12178

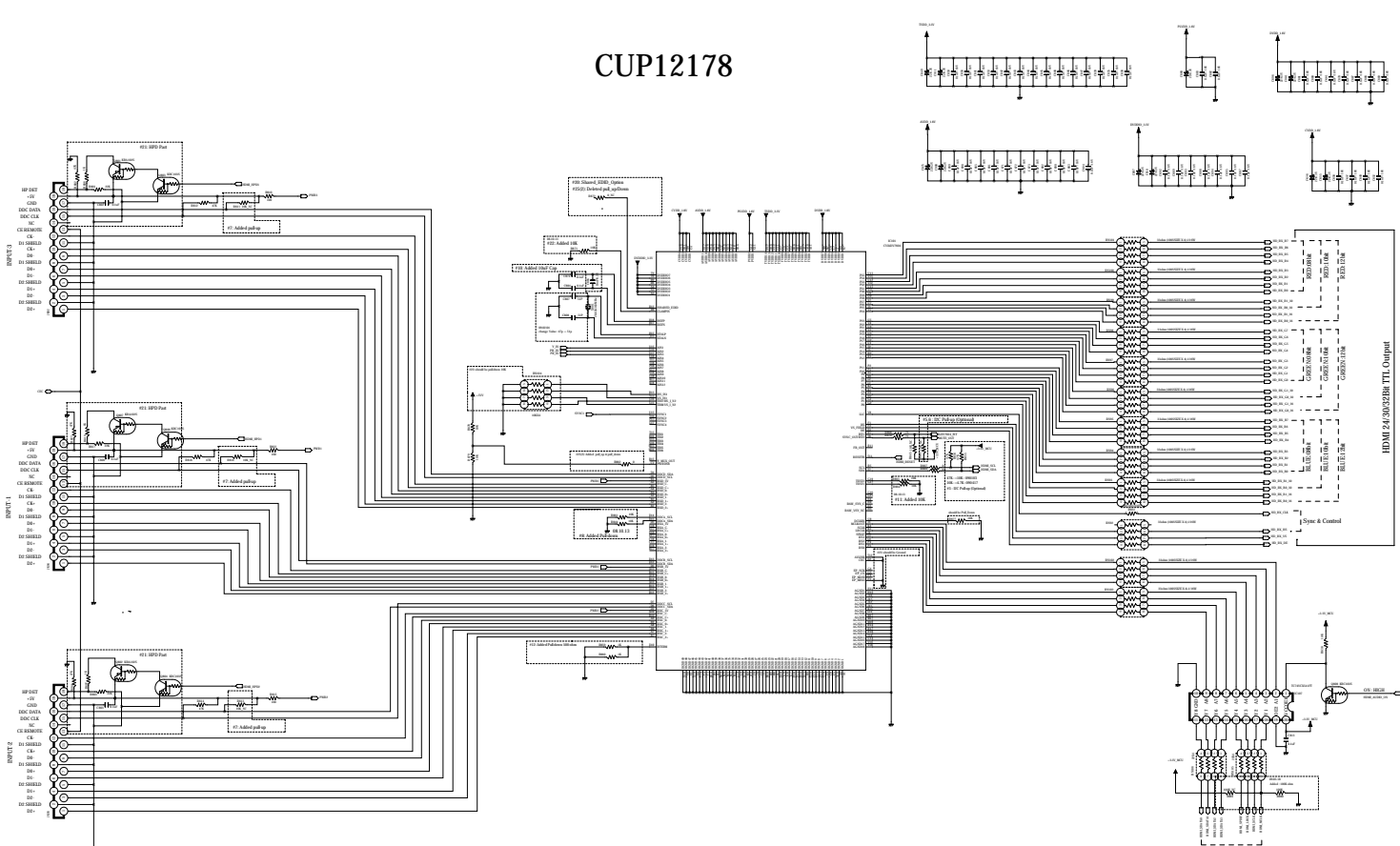

REVISION		2	4	6
1	3	5	7	
<b>SCHEMATIC DIAGRAM</b>				SHEET
MODEL	AVR160_HDMI_RX			1 2
DESIGN	CHECK	APPROVE	DRAWING NO	
S.K	W.Y.Y	K.S.W	CUP12178	
09.02.04	09.02.04	09.02.04	(HDMI-Output)	



# CUP12178

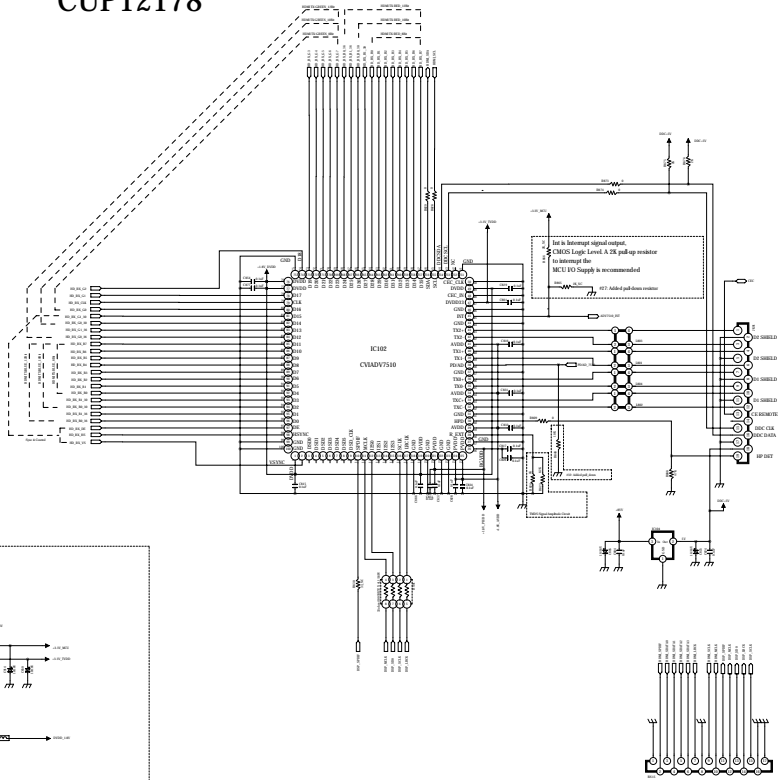
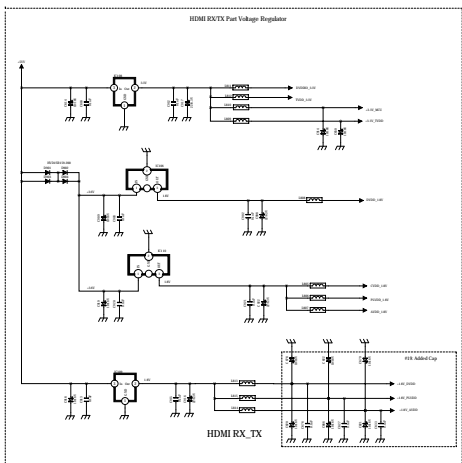
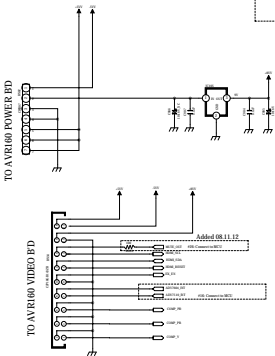
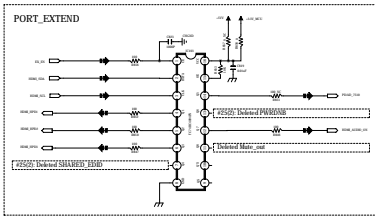

REVISION		2	4	6
1	3	5	7	
<b>SCHEMATIC DIAGRAM</b>				
MODEL	AVR160_HDMI_TX			SHEET 2 / 2
DESIGN	CHECK	APPROVE	DRAWING NO	
S.K	W.Y.Y	K.S.W	CUP12178	
09.02.04	09.02.04	09.02.04	(HDMI-Output)	



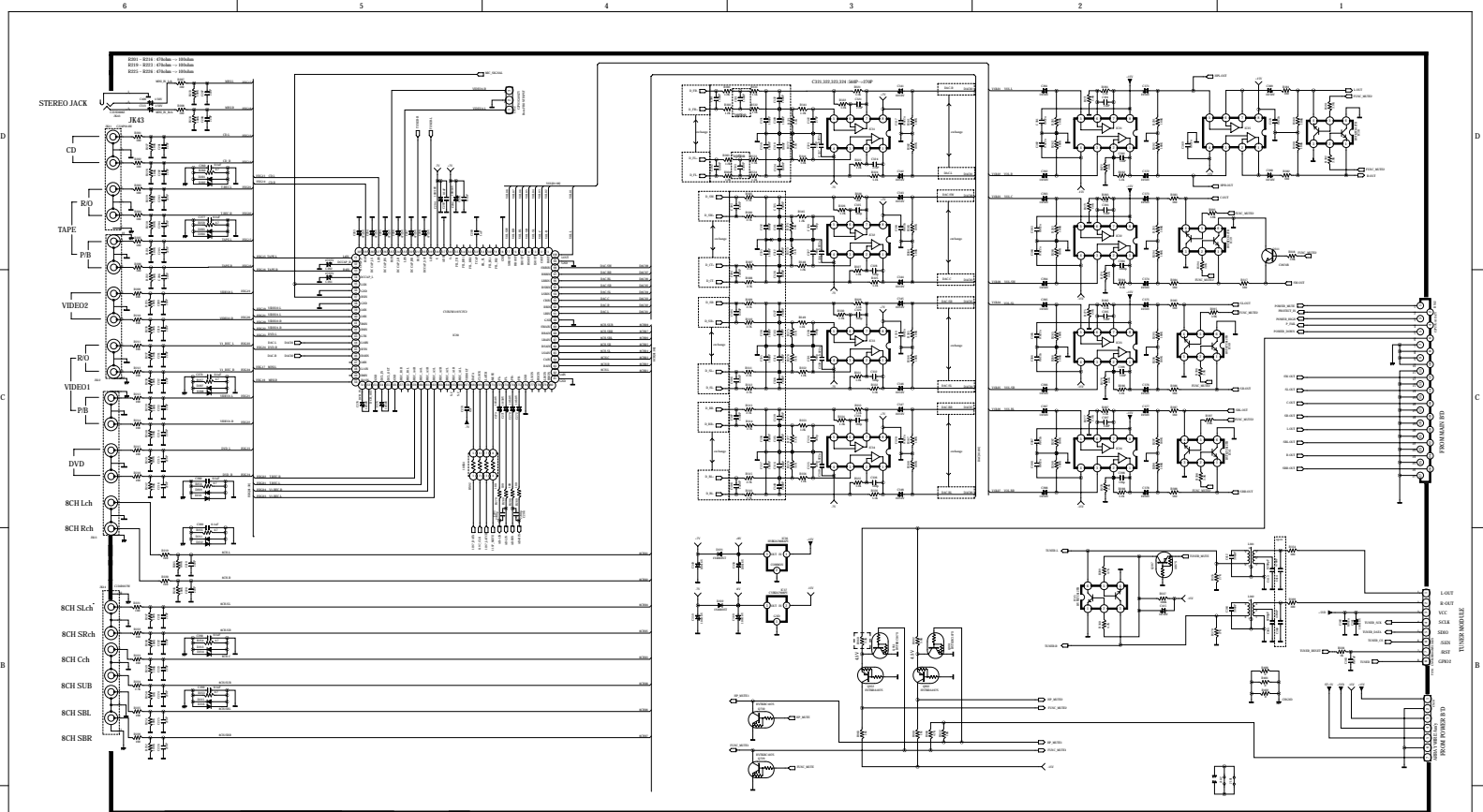

\*IMPORTANT SAFETY NOTES:  
 COMPONENTS IDENTIFIED BY MARK HAVE SPECIAL CHARACTERISTICS.  
 IMPORTANT FOR SAFETY: WHEN REPLACING ANY OF THESE COMPONENTS  
 USE ONLY MANUFACTURER'S SPECIFIED PARTS.  
 \*THE TAP OF RESISTANCE IS OHM.  
 K=1000 OHM, M=1000 K OHM  
 \*THE UNIT OF CAPACITANCE IS MICROFARAD (uF)  
 pF=10<sup>-12</sup> F  
 \*THIS SCHEMATIC DIAGRAM MAY MODIFIED AT ANY TIME WITH THE  
 IMPROVEMENT OF PERFORMANCE.



REVISION		2	4	6
1	3	5	7	

<b>SCHEMATIC DIAGRAM</b>				SHEET
MODEL <b>AVR 1600/160</b>				1 / 3
DESIGN	CHECK	APPROVE	DRAWING NO	
C.B.LEE	W.Y.YANG	G.S.WEY	<b>CUP12176SCEZ</b>	
08.10.18			(INPUT)	

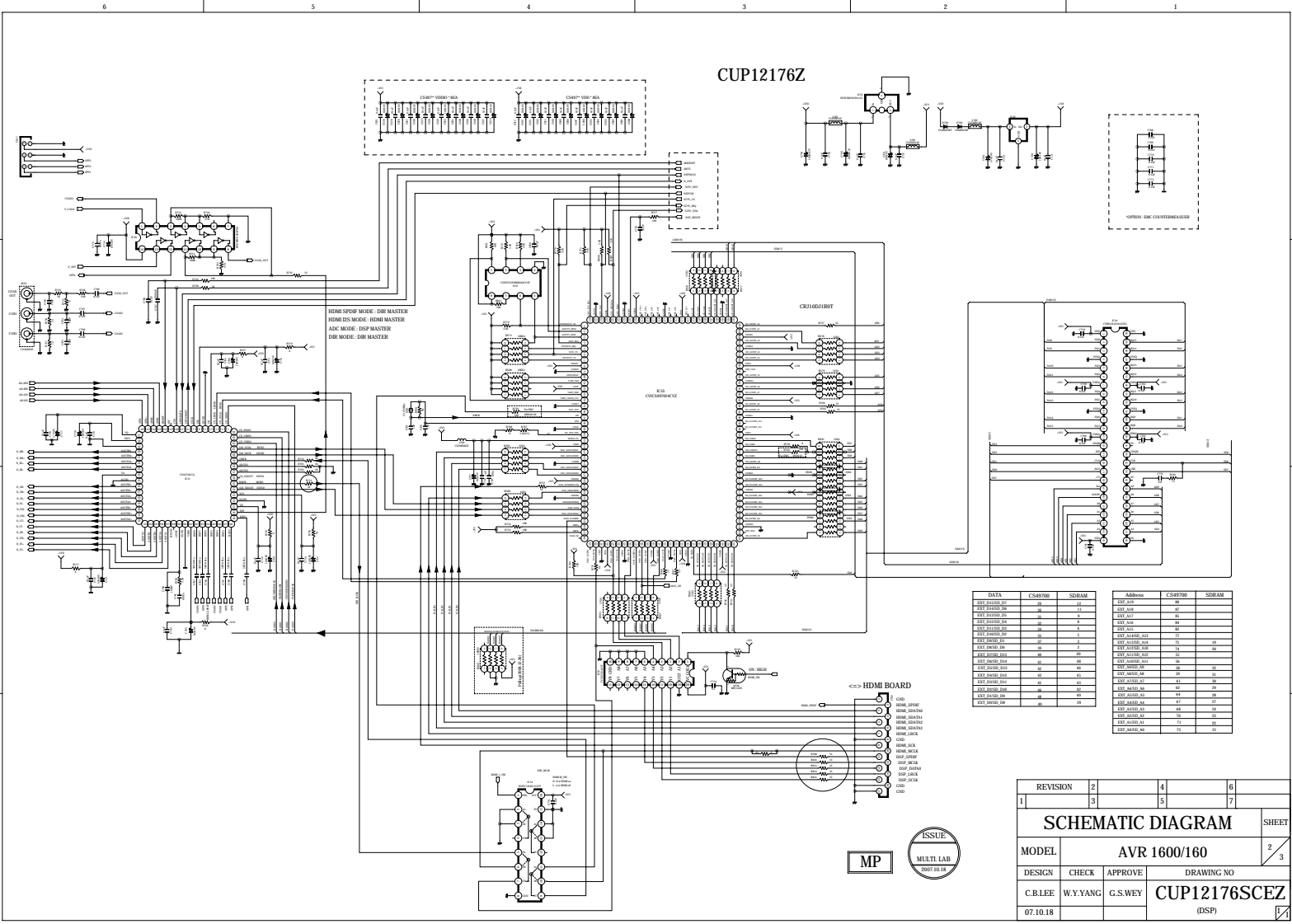

### CUP12176Z

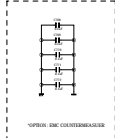
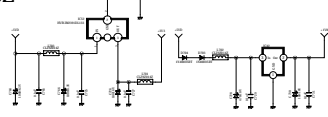
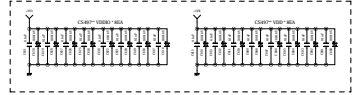

DATA	CS#(D)	SRAM
EXT CS(0) D0	00	00
EXT CS(0) D1	01	01
EXT CS(0) D2	02	02
EXT CS(0) D3	03	03
EXT CS(0) D4	04	04
EXT CS(0) D5	05	05
EXT CS(0) D6	06	06
EXT CS(0) D7	07	07
EXT CS(0) D8	08	08
EXT CS(0) D9	09	09
EXT CS(0) D10	0A	0A
EXT CS(0) D11	0B	0B
EXT CS(0) D12	0C	0C
EXT CS(0) D13	0D	0D
EXT CS(0) D14	0E	0E
EXT CS(0) D15	0F	0F

ADDRESS	CS#(D)	SRAM
EXT CS(0) A0	00	00
EXT CS(0) A1	01	01
EXT CS(0) A2	02	02
EXT CS(0) A3	03	03
EXT CS(0) A4	04	04
EXT CS(0) A5	05	05
EXT CS(0) A6	06	06
EXT CS(0) A7	07	07
EXT CS(0) A8	08	08
EXT CS(0) A9	09	09
EXT CS(0) A10	0A	0A
EXT CS(0) A11	0B	0B
EXT CS(0) A12	0C	0C
EXT CS(0) A13	0D	0D
EXT CS(0) A14	0E	0E
EXT CS(0) A15	0F	0F

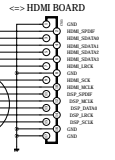

REVISION							SHEET
1	2	3	4	5	6	7	
<b>SCHEMATIC DIAGRAM</b>							2 / 3
<b>MODEL AVR 1600/160</b>							
DESIGN	CHECK	APPROVE	DRAWING NO				CUP12176SCEZ (DSF)
C.B.LEE	W.Y.YANG	G.S.WEY					
07.10.18							

MP

ISSUE  
MULTI LAB  
2007.03.18

FROM I/P & FRONT INPUT Bd

\* MODEL OPTION \*

MODEL	OP A(PIN94)
AVR1600USA	LOWER793-RDS OFF
AVR1600EUR	HIGHER792-RDS ON

U-COM	ADDRESS	AVRSS	AVRSS
PR 01	0000 0000 0000 0000	0000 0000 0000 0000	0000 0000 0000 0000
PR 02	0000 0000 0000 0000	0000 0000 0000 0000	0000 0000 0000 0000
PR 03	0000 0000 0000 0000	0000 0000 0000 0000	0000 0000 0000 0000
PR 04	0000 0000 0000 0000	0000 0000 0000 0000	0000 0000 0000 0000
PR 05	0000 0000 0000 0000	0000 0000 0000 0000	0000 0000 0000 0000
PR 06	0000 0000 0000 0000	0000 0000 0000 0000	0000 0000 0000 0000
PR 07	0000 0000 0000 0000	0000 0000 0000 0000	0000 0000 0000 0000
PR 08	0000 0000 0000 0000	0000 0000 0000 0000	0000 0000 0000 0000
PR 09	0000 0000 0000 0000	0000 0000 0000 0000	0000 0000 0000 0000
PR 10	0000 0000 0000 0000	0000 0000 0000 0000	0000 0000 0000 0000
PR 11	0000 0000 0000 0000	0000 0000 0000 0000	0000 0000 0000 0000
PR 12	0000 0000 0000 0000	0000 0000 0000 0000	0000 0000 0000 0000

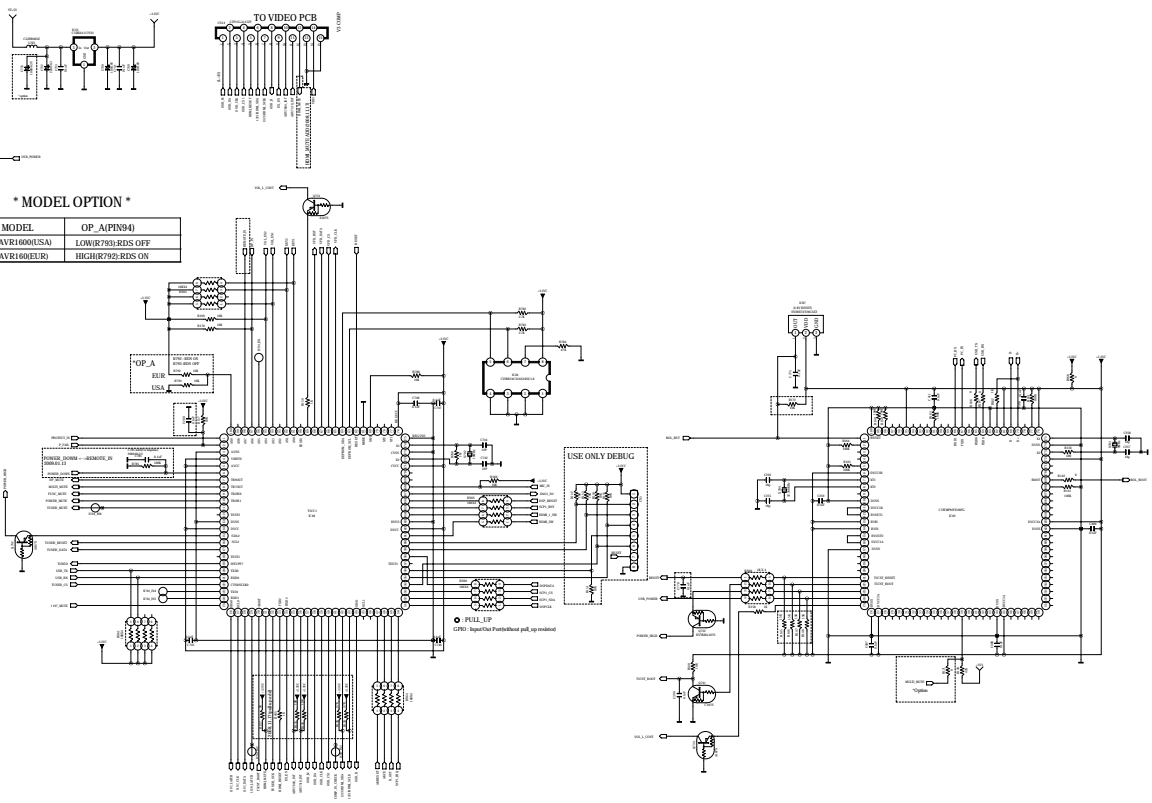

REVISION		2	4	6
1	3	5	7	

**SCHEMATIC DIAGRAM**

MODEL	AVR 1600/160			SHEET
DESIGN	CHECK	APPROVE	DRAWING NO	
C.B.LEE	W.Y.YANG	G.S.WEY	CUP12176SCEZ	
07.10.18			(CPU)	

