

"Junior"

'JUNIOR' 49 cc

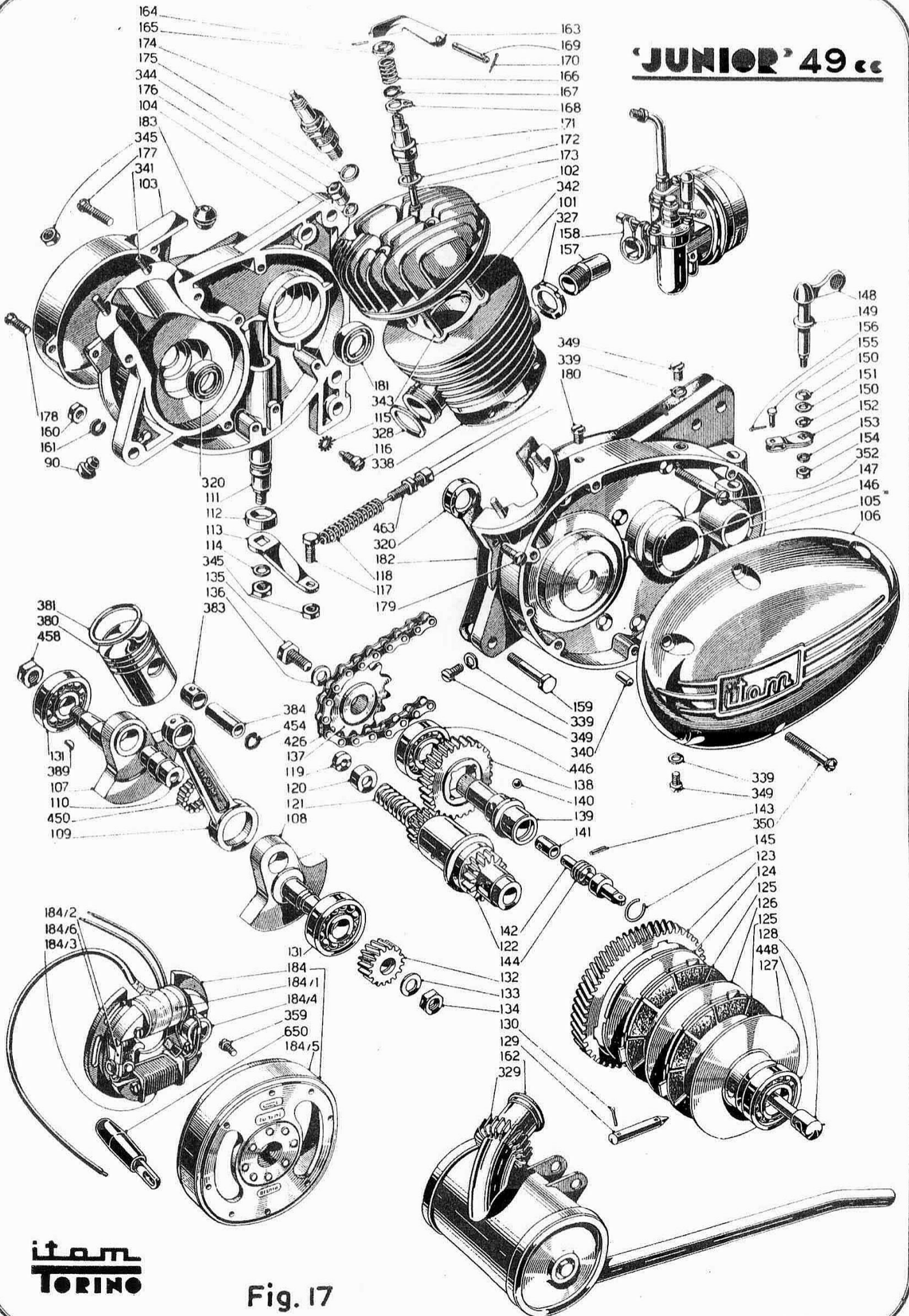

Fig. 17

ITAM
TORINO

ITOM "JUNIOR" 50cc. MOPED

ING PARTS :

	CYLINDER.....	(1)...	90.	Od.
	CYLINDER HEAD = BARE.....	(1)...	35.	Od.
/A	CYLINDER HEAD WITH DECOMPRESSER FITTED.....	(1)...	45.	Od.
	FLYWHEEL COVER.....	(1)...	18.	Od.
	CRANKCASE HALF = FLYWHEEL SIDE.....	(1)...	54.	Od.
	CRANKCASE HALF = CLUTCH SIDE.....	(1)...	60.	Od.
	CRANKCASE COVER = CLUTCH SIDE.....	(1)...	30.	Od.
	CRANKSHAFT = FLYWHEEL SIDE.....	(1)...	35.	Od.
	CRANKSHAFT = CLUTCH SIDE.....	(1)...	35.	Od.
/B/A	CRANKSHAFT ASSEMBLY COMPLETE.....	(1)...	100.	Od.
	CON ROD, WITH BUSH.....	(1)...	15.	Od.
	CRANK PIN.....	(1)...	7.	6d.
	CLUTCH OPERATING CAM.....	(1)...	7.	6d.
	OIL SEAL 12x22x7.....	(1)...	5.	Od.
	CLUTCH OPERATING ARM.....	(1)...	2.	6d.
	WASHER Ø 6.5mm internal Ø 13mm External.....	(1)...		2d.
	WASHER (STARRED).....	(1)...		2d.
	LOCATING SCREW FOR CLUTCH OPERATING CAM.....	(1)...	1.	9d.
	CLUTCH CABLE EYE BOLT.....	(1)...	1.	Od.
	CLUTCH OPERATING ARM RETURN SPRING.....	(1)...	1.	Od.
	COLLETT FOR CLUTCH OPERATING ROD.....	(2)...	1.	Od.
	COLLETT SEATING RING.....	(1)...	2.	Od.
	MAIN CLUTCH SPRING.....	(1)...	2.	6d.
	MAIN CLUTCH SHAFT BODY.....	(1)...	90.	Od.
	CLUTCH GEAR DRUM.....	(1)...	60.	Od.
	INNER CLUTCH PLATE.....	(1)...	5.	Od.
	CLUTCH PLATE WITH CORKS.....	(2)...	6.	Od.
	CLUTCH PLATE = PLAIN.....	(1)...	3.	Od.
	OUTER CLUTCH PLATE WITH BOSS.....	(1)...	15.	Od.
	CLUTCH OPERATING ROD.....	(1)...	6.	Od.
	CLUTCH ASSEMBLY RETAINING PIN.....	(1)...	1.	6d.
	SPLIT PIN Ø 1 mm.....	(2)...		1d.
	CRANKSHAFT MAIN BEARING RIV. 2 B E.....	(2)...	18.	Od.
	DRIVE GEAR Z=15.....	(1)...	18.	Od.
	WASHER FOR DRIVE GEAR.....	(1)...		2d.
	CRANKSHAFT NUT = DRIVE SIDE.....	(1)...		9d.
	ENGINE SPROCKET LOCKING BOLT.....	(1)...	1.	6d.
	WASHER FOR SPROCKET BOLT.....	(1)...		2d.
	ENGINE SPROCKET.....	(1)...	20.	Od.
	ENGAGING GEAR Z=34.....	(1)...	30.	Od.
	ENGAGING GEAR SHAFT.....	(1)...	50.	Od.
	BALL BEARINGS 1/4".....	(4)...		1d.
	DISTANCE COLLAR FOR GEAR OPERATING ROD.....	(1)...	2.	Od.
	GEAR OPERATING ROD.....	(1)...	5.	Od.
	SPRING SPLIT PIN Ø 2mm.....	(1)...		6d.
	BALL BEARING ENGAGING COLLAR.....	(1)...	2.	6d.
	SPRING CIRCLIP.....	(1)...		3d.
	CRANKCASE BUSH FOR ENGINE SPROCKET SHAFT.....	(1)...	4.	Od.
	CRANKCASE BUSH FOR MAIN CLUTCH SHAFT.....	(1)...	7.	Od.
	ENGAGING LEVER OPERATING ARM.....	(1)...	9.	Od.
	"" "" collar.....	(1)...	1.	Od.
	"" "" SPRING TENSION WASHER.....	(2)...		2d.
	"" "" WASHER.....	(1)...		2d.
	"" "" CONNECTING ARM.....	(1)...	2.	Od.
	"" "" WASHER Ø 5mm.....	(1)...		2d.
	"" "" LOCK NUT.....	(1)...		6d.
	"" "" CONNECTING ARM PIN.....	(1)...	1.	3d.
	"" "" "SPLIT PIN.....	(1)...		1d.
	CARBURETTOR INDUCTION TUBE.....	(1)...	4.	6d.
	CARBURETTOR COMPLETE.....	(1)...	75.	Od.
	SILENCER FIXING BOLT.....	(1)...	2.	Od.
	LOCK NUT FOR SILENCER FIXING BOLT.....	(1)...		6d.
	WASHER.....	(1)...		1d.

FIG.

162	SILENCER COMPLETE.....	(1)...	27.	Od.
162/1	SILENCER END PLATE.....	(2)...	2.	Od.
162/2	SILENCER STUD BOLT.....	(1)...	1.	Od.
162/3	SILENCER STUD BOLT NUT.....	(2)...		6d.
163	DECOMPRESSER ARM.....	(1)...	1.	6d.
164	DECOMPRESSER ARM SPLIT PIN.....	(1)...		1d.
165	DECOMPRESSER SPRING CUP WASHER.....	(1)...		6d.
166	DECOMPRESSER SPRING.....	(1)...		4d.
167	DECOMPRESSER CIRCLIP.....	(1)...		6d.
168	DECOMPRESSER CABLE SEAT FLANGE.....	(1)...		9d.
169	DECOMPRESSER ARM PIVOT PIN.....	(1)...		9d.
170	DECOMPRESSER ARM PIVOT PIN SPLIT PIN.....	(2)...		1d.
171	DECOMPRESSER MAIN BODY.....	(1)...	4.	Od.
172	DECOMPRESSER COPPER/ASBESTOS WASHER.....	(1)...		6d.
173	DECOMPRESSER VALVE.....	(1)...	2.	Od.
163/73	DECOMPRESSER COMPLETE.....	(1)...	10.	Od.
174	SPARKING PLUG.....	(1)...	5.	Od.
175	SPARKING PLUG WASHER.....	(1)...		3d.
176	WASHER FOR CYLINDER HEAD NUT.....	(4)...		2d.
177	FLYWHEEL COVER SCREW = LONG.....	(1)...		9d.
178	FLYWHEEL COVER SCREW = SHORT.....	(2)...		6d.
179	CRANKCASE SCREW = EXTERNAL.....	(1)...		9d.
180	CRANKCASE BREATHER SCREW.....	(1)...		9d.
181	OIL SEAL FOR ENGINE SPROCKET SHAFT.....	(1)...	5.	Od.
182	CRANKCASE GASKET.....	(1)...	1.	9d.
183	RUBBER GROMET FOR H.T. LEAD.....	(1)...		9d.
184	FLYWHEEL MAGNETO COMPLETE.....	(1)...	200.	Od.
184/1	H.T. COIL.....	(1)...	45.	Od.
184/2	POINTS ASSEMBLY.....	(1)...	8.	6d.
184/3	LIGHTING COIL.....	(1)...	25.	Od.
184/4	CONDENSER.....	(1)...	7.	6d.
184/5	FLYWHEEL ONLY.....	(1)...	100.	Od.
184/6	STATOR PLATE.....	(1)...	15.	Od.
90	LIGHTING LEAD RUBBER GROMET.....	(1)...		9d.
320	CRANKSHAFT OIL SEAL 24x15x7.....	(2)...	5.	Od.
327	CARBURETTOR INDUCTION TUBE LOCK RING.....	(1)...	4.	Od.
328	EXHAUST PIPE GASKET.....	(1)...		9d.
329	EXHAUST PIPE LOCK RING.....	(1)...	4.	6d.
338	CYLINDER BASE GASKET.....	(1)...		9d.
339	FIBRE WASHER.....	(3)...		2d.
341	CYLINDER BASE STUD BOLT.....	(4)...	1.	Od.
342	CYLINDER HEAD STUD BOLT, =FRONT, LONG.....	(2)...	1.	3d.
343	CYLINDER HEAD STUD BOLT, =REAR, SHORT.....	(2)...	1.	3d.
344	CYLINDER HEAD NUT 6x1mm.....	(4)...		6d.
345	CYLINDER BASE NUT 6x1mm.....	(4)...		4d.
349	OIL FILLER PLUG.....	(1)...		9d.
350	CRANKCASE COVER SCREW = CLUTCH SIDE.....	(6)...		9d.
352	CRANKCASE SCREW = CLUTCH SIDE.....	(6)...		9d.
359	STATOR PLATE SCREW.....	(3)...		6d.
380	PISTON = standard Ø 40mm.....	(1)...	18.	Od.
380/1	PISTON = oversize Ø 40.3mm.....	(1)...	18.	Od.
380/2	PISTON = oversize Ø 40.6mm.....	(1)...	18.	Od.
380/3	PISTON = oversize Ø 41mm.....	(1)...	18.	Od.
381	PISTON RING = standard Ø 40mm.....	(3)...	2.	Od.
381/1	PISTON RING = oversize Ø 40.3mm.....	(2)...		Od.
381/2	PISTON RING = oversize Ø 40.6mm.....	(2)...		Od.
381/3	PISTON RING = oversize Ø 41mm.....	(2)...		Od.
383	SMALL END BUSH.....	(1)...	2.	6d.
384	GUDGEON PIN.....	(1)...	2.	6d.
389	WOODRUFF KEY.....	(1)...		9d.
426	TRANSMISSION CHAIN 1/2" x 3/16th".....	(1)...	21.	Od.
426/1	CHAIN CONNECTING LINK.....	(1)...	1.	9d.
426/2	CHAIN HALF LINK.....	(1)...	1.	9d.
446	ROLLER BEARING RIV 0 1 A.....	(1)...	18.	Od.
448	ROLLER BEARING RIV 3 A E.....	(1)...	18.	Od.
450	BIG END NEEDLE ROLLERS 4x8mm.....	(17)...		6d.
454	GUDGEON PIN CIRCLIP.....	(2)...		6d.
458	CRANKSHAFT LOCK NUT = FLYWHEEL SIDE.....	(1)...		9d.
463	CABLE ADJUSTER.....	(1)...	1.	6d.
650	PLUG COVER (SUPPRESSED).....	(1)...	2.	6d.

10

'JUNIOR' 49 cc

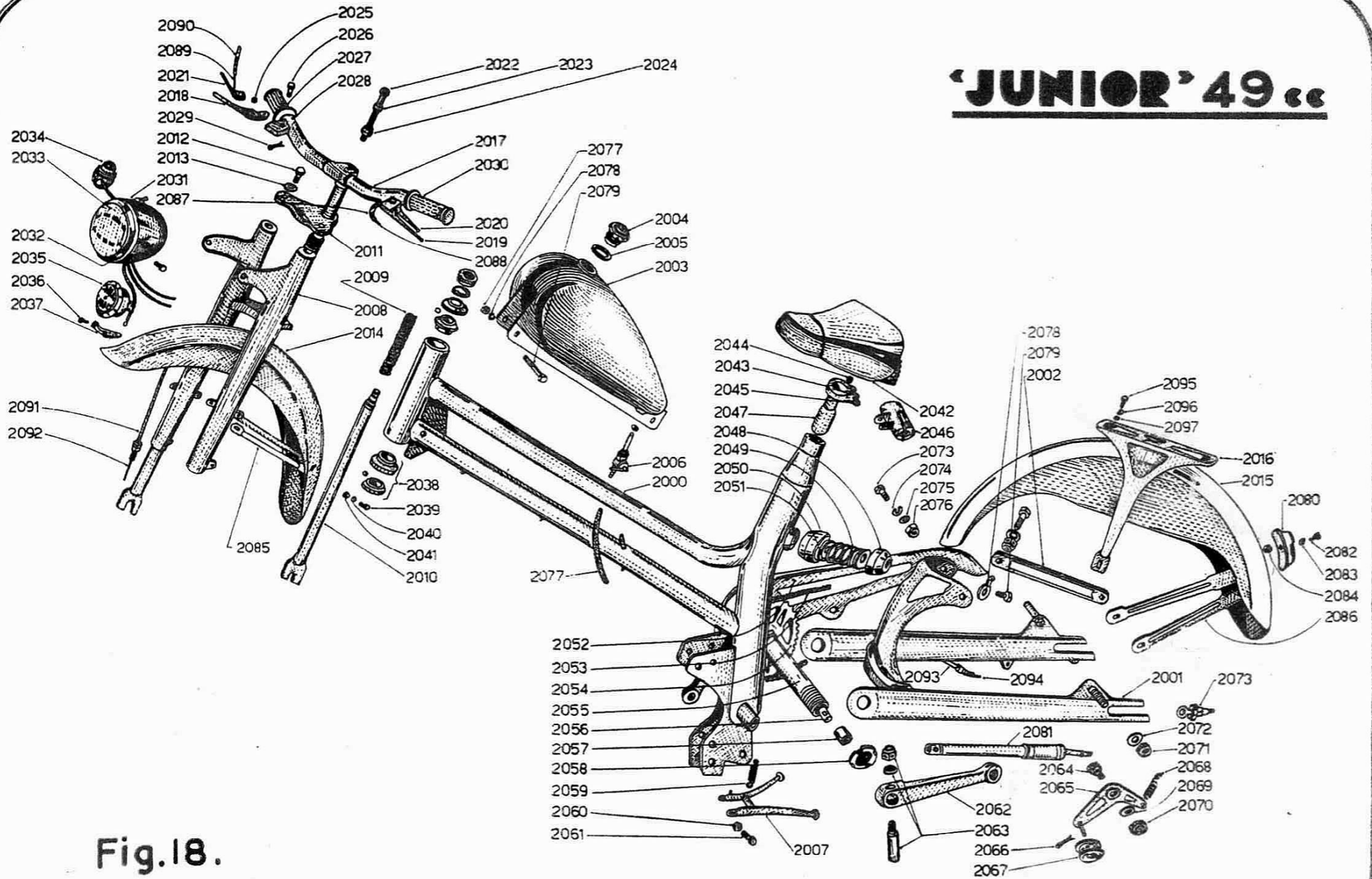

Fig.18.

FRAME PARTS:

2000	FRAME = BODY ONLY.....	(1)	160.	0d.	2047	SADDLE PILLAR.....	(1)	2.	6d.
2001	REAR FORK BLADE ASSEMBLY.....	(1)	66.	0d.	2048	REAR SUSPENSION SPRING CHROME COVER-REAR.....	(1)	6.	0d.
2002	REAR FORK SUPPORT STAYS.....	(2)	10.	0d.	2049	REAR SUSPENSION SPRING.....	(1)	9.	0d.
2003	PETROL TANK = BODY ONLY.....	(1)	80.	0d.	2050	REAR SUSPENSION SPRING CHROME COVER-FRONT.....	(1)	7.	0d.
2004	PETROL TANK = FILLER CAP.....	(1)	2.	6d.	2051	REAR SUSPENSION SPRING SUPPORTWASHER.....	(2)	1.	3d.
2005	PETROL TANK = FILLER CAP WASHER.....	(1)		6d.	2052	CHAIN COVER.....	(1)	15.	0d.
2006	PETROL TANK = TAP.....	(1)	6.	6d.	2053	CYCLE CHAIN.....	(1)	12.	0d.
2007	PROPSTAND.....	(1)	17.	6d.	2053/1	FREEWHEEL SPROCKET.....	(1)	15.	0d.
2008	FRONT FORKS = BODY ONLY.....	(1)	70.	0d.	2054	CHAIN WHEEL, with RIGHT HAND CRANK.....	(1)	21.	0d.
2008/A	FRONT FORKS COMPLETE.....	(1)	140.	0d.	2055	PEDAL SHAFT OUTER TUBE.....	(1)	15.	0d.
2009	FRONT FORK SPRING.....	(2)	6.	0d.	2056	PEDAL SPINDLE.....	(1)	9.	0d.
2010/1	FRONT FORK SHAFT = LEFT HAND.....	(1)	20.	0d.	2057	BUSH FOR PEDAL SHAFT OUTER TUBE.....	(2)	2.	6d.
2010/2	FRONT FORK SHAFT = RIGHT HAND, with brake stop	(1)	22.	6d.	2058	LOCK RING FOR PEDAL SHAFT OUTER TUBE.....	(2)	2.	6d.
2011	FRONT FORK = TOP PLATE.....	(1)	6.	0d.	2059	PROPSTAND RETURN SPRING.....	(1)		9d.
2012	FRONT FORK = TOP PLATE BOLT.....	(2)	1.	6d.	2060	PROPSTAND NUT.....	(2)		6d.
2013	FRONT FORK = WASHER FOR TOP PLATE BOLT.....	(2)		2d.	2061	PROPSTAND BOLT.....	(2)		9d.
2014	FRONT MUDGUARD.....	(1)	27.	6d.	2062	LEFT HAND PEDAL CRANK.....	(1)	8.	6d.
2015	REAR MUDGUARD.....	(1)	30.	0d.	2063	COTTER PIN, COMPLETE.....	(2)	1.	3d.
2016	PARCEL CARRIER.....	(1)	20.	0d.	2064	CHAIN TENSIONER SPINDLE BOLT.....	(1)	1.	3d.
2017	HANDLEBARS COMPLETE.....	(1)	70.	0d.	2065	CHAIN TENSIONER MAIN BODY.....	(1)	3.	0d.
2017/1	HANDLEBAR = BEND AND STEM, less controls.....	(1)	45.	0d.	2065/1	CHAIN TENSIONER = COMPLETE ASSEMBLY.....	(1)	8.	0d.
2018	HANDLEBAR = REAR BRAKE LEVER.....	(1)	5.	0d.	2066	SPLIT PIN.....	(1)		1d.
2019	HANDLEBAR = CLUTCH LEVER.....	(1)	5.	0d.	2067	CHAIN TENSIONER = ROLLER.....	(1)	2.	0d.
2020	HANDLEBAR = FRONT BRAKE LEVER.....	(1)	5.	0d.	2068	CHAIN TENSIONER = SPRING.....	(1)	1.	0d.
2021	HANDLEBAR = DECOMPRESSOR LEVER.....	(1)	4.	0d.	2069	WASHER.....	(1)		3d.
2022	HANDLEBAR = EXPANDER BOLT COMPLETE.....	(1)	3.	6d.	2070	LOCK NUT FOR SPINDLE BOLT.....	(1)		3d.
2023	HANDLEBAR = EXPANDER BOLT WASHER.....	(1)		3d.	2071	LOCK NUT FOR REAR FORK STAY.....	(2)		6d.
2024	HANDLEBAR = EXPANDER BOLT CONE.....	(1)	1.	3d.	2072	WASHER FOR ABOVE LOCK NUT.....	(2)		2d.
2025	HANDLEBAR = LEVER CABLE NIPPLES (BARREL).....	(4)		9d.	2073	CHAIN ADJUSTER.....	(2)	2.	6d.
2025/A	HANDLEBAR = CABLE STOP NIPPLES.....	(2)		6d.	2074	SPRING WASHER.....	(2)		1d.
2026	HANDLEBAR = LEVER PIVOT BOLTS.....	(2)	1.	0d.	2075	WASHER.....	(2)		1d.
2027	HANDLEBAR = RIGHT HAND RUBBER GRIP.....	(1)	1.	6d.	2076	DOVE NUT.....	(2)		9d.
2028	THROTTLE CONTROL COMPLETE.....	(1)	12.	0d.	2077	PETROL TUBING.....	(1)	1.	0d.
2029	SPLIT PIN.....	(2)		1d.	2078	CABLE INSERT WASHER FOR MUDGUARD.....	(1)	1.	0d.
2030	HANDLEBAR = LEFT HAND RUBBER GRIP.....	(1)	1.	6d.	2079	MUDGUARD BOLT.....	(1)		9d.
2031	HEADLAMP COMPLETE.....	(1)	32.	6d.	2080	REAR LAMP COMPLETE with bulb.....	(1)	11.	3d.
2031/1	HEADLAMP = REFLECTOR.....	(1)	8.	6d.	2080/1	REAR LAMP RIM.....	(1)	1.	9d.
2031/2	HEADLAMP = BULB 6v5w.....	(1)	1.	6d.	2080/2	REAR LAMP GLASS REFLECTOR.....	(1)	1.	3d.
2031/3	HEADLAMP = REFLECTOR SPRING.....	(3)		4d.	2080/3	REAR LAMP FESTOON BULB.....	(1)	2.	9d.
2031/4	HEADLAMP = RIM SCREW.....	(1)		6d.	2081	PUMP, COMPLETE.....	(1)	7.	6d.
2032	HEADLAMP = RIM.....	(1)	7.	0d.	2081/1	PUMP CONNECTOR.....	(1)	1.	6d.
2033	HEADLAMP = GLASS.....	(1)	2.	6d.	2082	REAR LAMP FIXING BOLT.....	(2)		4d.
2034	HANDLEBAR SWITCH.....	(1)	10.	0d.	2083	WASHER.....	(2)		1d.
2035	ELECTRIC HORN.....	(1)	13.	0d.	2084	NUT FOR REARLAMP BOLT.....	(2)		3d.
2036	SCREW FOR ELECTRIC HORN.....	(2)		4d.	2085	FRONT MUDGUARD STAY.....	(1)	5.	0d.
2037	MOUNTING PLATE FOR ELECTRIC HORN.....	(1)	1.	6d.	2086	REAR MUDGUARD STAY.....	(1)	5.	0d.
2038	STEERING COLUMN HEAD RACE SET COMPLETE.....	(1)	15.	0d.	2087/8	CLUTCH CABLE COMPLETE.....	(1)	4.	0d.
2039	MUDGUARD BOLT.....	(4)		9d.	2088	CLUTCH CABLE = INNER ONLY.....	(1)	2.	0d.
2040	WASHER.....	(4)		2d.	2089/90	DECOMPRESSOR CABLE COMPLETE.....	(1)	3.	0d.
2041	NUT FOR MUDGUARD BOLT.....	(4)		4d.	2090	DECOMPRESSOR CABLE = INNER ONLY.....	(1)	1.	6d.
2042	SADDLE = COMPLETE.....	(1)	25.	0d.	2091/2	FRONT BRAKE CABLE COMPLETE.....	(1)	2.	6d.
2042/1	SADDLE = REPLACEMENT COVER.....	(1)	12.	6d.	2093/4	REAR BRAKE CABLE COMPLETE.....	(1)	4.	0d.
2042/2	SADDLE = REPLACEMENT SPIRAL SPRING.....	(2)	2.	6d.	2095	PARCEL CARRIER BOLT.....	(2)		6d.
2043	SADDLE CLAMP RING.....	(1)	2.	6d.	2096	WASHER FOR BOLT.....	(2)		1d.
2044	NUT FOR SADDLE CLAMP BOLT.....	(1)		6d.	2097	WASHER FOR BOLT.....	(2)		2d.
2045	SADDLE CLAMP BOLT.....	(1)	1.	0d.	2098	THROTTLE CABLE COMPLETE.....	(1)	2.	6d.
2046	TOOL BOX COMPLETE.....	(1)	7.	6d.					
2046/1	TOOL BOX = LID ONLY.....	(1)	2.	0d.					
2046/2	TOOL BOX = SPRING CLIP.....	(1)		6d.					

"JUNIOR" 49 cc.

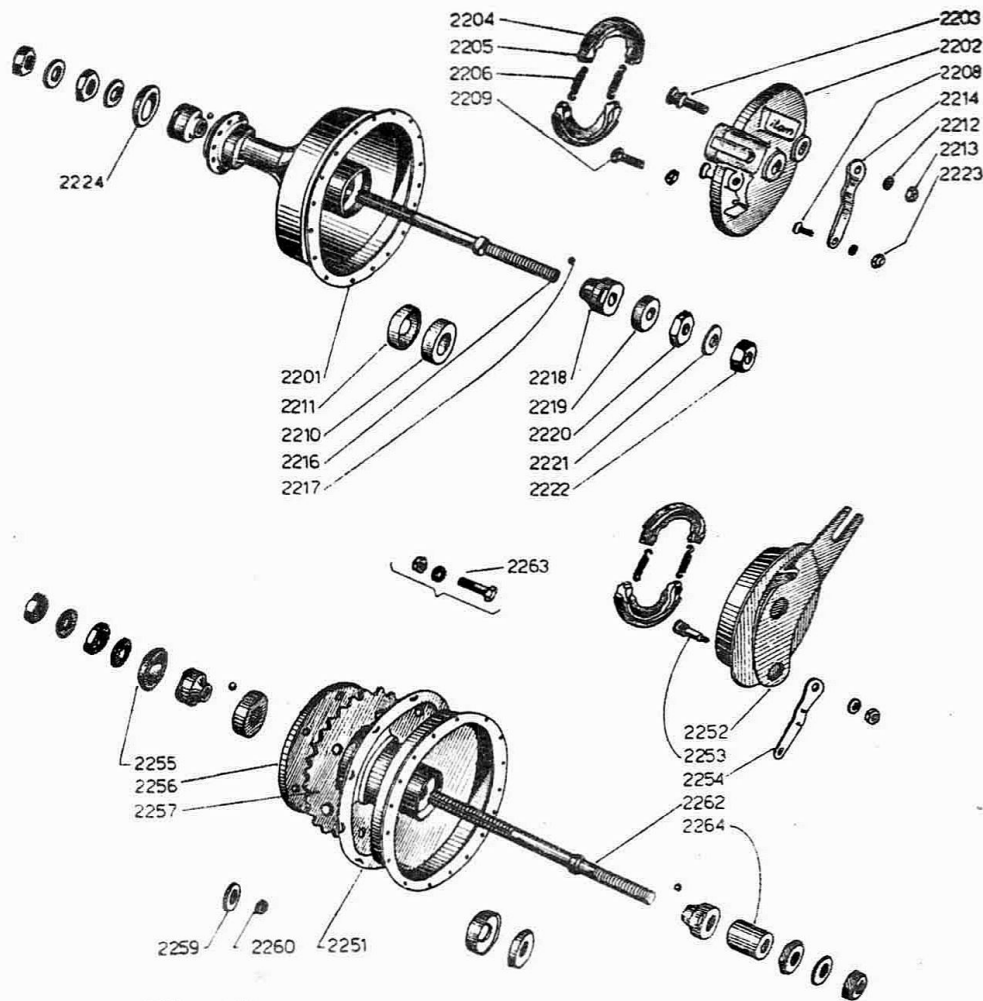

Fig. 19

HUBS AND WHEEL ASSEMBLIES :

FRONT HUB :

2200	FRONT HUB COMPLETE	(1) ..	70.	0d.
2201	FRONT HUB SHELL	(1) ..	50.	0d.
2202	FRONT HUB BACK PLATE	(1) ..	12.	0d.
2203	FRONT HUB OPERATING CAM	(1) ..	3.	0d.
2204	BRAKE LINING = FRONT AND REAR (with rivets) ..	(4) ..	3.	4d.
2205	BRAKE SHOE WITH LINING	(4) ..	6.	0d.
2206	BRAKE SHOE SPRINGS	(2) ..		9d.
2207	BRAKE SHOE SET COMPLETE WITH LININGS AND SPRING ..	(2) ..	13.	6d.
2208	BRAKE CABLE EYE BOLT	(2) ..		9d.
2209	CABLE ADJUSTER	(2) ..	1.	6d.
2210	DUST COVER	(2) ..	1.	0d.
2211	HUB CUPS	(4) ..	3.	0d.
2212	BRAKE CAM WASHER	(2) ..		2d.
2213	BRAKE CAM LOCK NUT	(2) ..		6d.
2214	FRONT BRAKE OPERATING LEVER	(1) ..	2.	0d.
2215	FRONT BRAKE SPINDLE COMPLETE	(1) ..	12.	0d.
2216	FRONT BRAKE SPINDLE = BARE	(1) ..	3.	0d.
2217	BALL BEARINGS 1/2"	(4) ..		1d.
2218	CONES	(4) ..	2.	6d.
2219	SPACER	(4) ..	1.	0d.
2220	CONE LOCK NUT	(4) ..	1.	0d.
2221	PEGGED WASHER	(2) ..		6d.
2222	WHEEL NUT	(4) ..	1.	0d.
2223	NUT FOR BRAKE CABLE EYE BOLT	(2) ..		3d.
2224	DUST COVER	(1) ..	1.	0d.

REAR HUB: Parts not repeated, are interchangeable with front hub.

2250	REAR HUB COMPLETE	(1) ..	90.	0d.
2251	REAR HUB SHELL, WITH CUPS MOUNTED	(1) ..	65.	0d.
2252	REAR HUB BACK PLATE	(1) ..	14.	0d.
2253	REAR HUB OPERATING CAM	(1) ..	3.	0d.
2254	REAR HUB OPERATING LEVER	(1) ..	2.	0d.
2255	DUST COVER	(1) ..	1.	0d.
2256	REAR SPROCKET COVER	(1) ..	2.	0d.
2257	REAR SPROCKET = 28 tooth	(1) ..	15.	0d.
2258	Nil.			
2259	REAR SPROCKET HUBBERS	(5) ..		6d.
2260	REAR SPROCKET COLLARS	(5) ..		9d.
2261	REAR BRAKE SPINDLE COMPLETE	(1) ..	12.	0d.
2262	REAR BRAKE SPINDLE = BARE	(1) ..	3.	0d.
2263	REAR SPROCKET BOLT SET	(5) ..	1.	0d.
2264	SPACER	(1) ..	1.	0d.

WHEEL GROUP :

2300	FRONT WHEEL COMPLETE, less tyre and tube ..	(1) ..	130.	0d.
2301	REAR WHEEL COMPLETE, less tyre and tube ..	(1) ..	150.	0d.
2302	WHEEL RIM, front or rear	(2) ..	21.	0d.
2303	TYRES 24x1 1/2"	(2) ..	37.	6d.
2304	INNER TUBES 24x1 1/2"	(2) ..	12.	6d.
2305	SPOKES WITH NIPPLES 235mm	(36) ..		6d.
2306	SPOKES WITH NIPPLES 220/223mm	(36) ..		6d.
2307	RIM TAPE	(2) ..	1.	3d.
2308	INNER TUBE VALVE COMPLETE	(2) ..	1.	3d.
2309	INNER TUBE VALVE CAP	(2) ..		4d.