

## HISTORY INFORMATION FOR THE FOLLOWING MANUAL:

CORDON58 - 12/20/2018 12:04 PM

# *SERVICE MANUAL (COMMON)*

GN1G CHASSIS

Segment: XM-H

<b>Version</b>	<b>Date</b>	<b>Subject</b>
1	3/2015	1 <sup>st</sup> Issue.
2	7/2015	Updates for : 1. Adjustment Section ( pg 76 ) 2. T/shooting : Remove Tuner related checking ( pg20 ) 3. Triage Chart : Delete Local I2C from 3x blinking ( pg 10 ) 4. Self Diagnosis :Remove TU_DEMOD error from 3x blinking & add remark (pg 9)

LCD TV  
**SONY**<sup>®</sup>  
9-888-168-02

For SM - Unique , please refer :

9-888-168-Ax ( America )

9-888-168-Cx ( China )

9-888-168-Ex ( Europe )

9-888-168-Px ( Pan Asia )

# *SERVICE MANUAL (COMMON)*

---

GN1G CHASSIS

Segment: XM-H

LCD TV  
**SONY**<sup>®</sup>

# MODEL LIST

---

THIS SERVICE MANUAL CONTAINS COMMON INFORMATION FOR BELOW REGIONS AND MODELS:

REGION

**CORDON58 - 12/20/2018 12:04 PM**

ASIA

CHINA

AMERICA

EUROPE

MODEL

KDL-65W8\*C

KDL-75W8\*C

---

# TABLE OF CONTENTS

<u>Section Title</u>	<u>Page</u>	<u>Section Title</u>	<u>Page</u>
<b>1. SAFETY NOTES</b>		<b>4. SERVICE ADJUSTMENTS</b>	
1-1. Warnings and Caution.....	5	4-1. Accessing Service Mode .....	76
1-2. Caution Handling of LCD Panel .....	5	4-2. Accessing Software Version.....	76
1-3. Caution About the Lithium Batter.....	6	4-3. Accessing Serial Number Edit.....	77
1-4. Safety Check Out .....	6	4-4. Accessing Model Number Setting.....	78
1-5. Leakage Test .....	6	4-5. W/B Adjustment via Service Mode.....	79
1-6. How to Find a Good Earth Ground.....	6	4-6. WB/Mura/CUC data transfer via Service Mode.....	79
1-7. Lead Free Information.....	7	4-7. HDD Performance Check.....	80
1-8. Handling the Flexible Flat Cable (FFC).....	7	4-8. HDD Re-Register.....	80
<b>2. SELF DIAGNOSTIC FUNCTION</b>		4-9. Accessing Self Diagnostic Menu.....	81
2-1. Overview of Control Buttons .....	8	4-10. Summary of Service Control.....	81
2-2. LED Display Control .....	9	<b>5. DIAGRAMS</b>	
2-3. LED Pattern.....	9	5-1. Circuit Board Location .....	82
2-4. Standby LED Error Display.....	9	5-2. Block Diagram .....	83
2-5. Triage Chart .....	10	5-3. Connector Diagram .....	89
<b>3. TROUBLE SHOOTING</b>			
3-1. No Power.....	11		
3-2. LED Blinking.....	18		
3-3. No Sound.....	30		
3-4. No Picture.....	42		
3-5. Side Buttons Malfunction.....	66		
3-6. IR Remote Commander Malfunction.....	68		
3-7. Light Sensor Error.....	70		
3-8. Network Malfunction: Ethernet (Wired).....	72		
3-9. Wireless Network Malfunction.....	73		
3-10. Bluetooth Malfunction.....	75		

Please refer Service Manual – Unique for below information :

- Safety Warnings
- Wire Dressing
- Circuit Board Location
- Disassembly and Exploded View.

## SECTION 1 SAFETY NOTES

### 1-1. Warnings and Caution

- 1) These servicing instructions are for use by qualified service personnel only.
- 2) To reduce the risk of electric shock, do not perform any servicing other than that contained in the operating instructions unless you are qualified to do so.
- 3) An isolation transformer should be used during any service to avoid Possible shock hazard, because of live chassis. The chassis of this receiver is directly connected to the ac power line.
- 4) Be sure to follow these guidelines to protect your property and avoid causing serious injury :
  - Carry the TV with an adequate number of people; larger size TVs require two or more people.
  - Correct hand placement while carrying the TV is very important for safety and to avoid damages.
- 5) Components identified by shading and  mark on the exploded views, and in the parts list are critical for safe operation. Replace these components with Sony parts whose part numbers appear as shown in this manual or in supplements published by Sony. Circuit adjustments that are critical for safe operation are identified in this manual. Follow these procedures whenever critical components are replaced or improper operation is suspected.

### 1-2. Caution Handling of LCD Panel

When repairing the LCD Panel, make sure you are grounded with a wrist band. When repairing the LCD Panel on the wall, the panel must be secured using the 4 mounting holes on the rear cover.

- 1) Do not press the panel or frame edge to avoid the risk of electric shock.
- 2) Do not scratch or press on the panel with any sharp objects.
- 3) Do not leave the module in high temperature or in areas of high humidity for an extended period of time.
- 4) Do not expose the LCD panel to direct sunlight.
- 5) Avoid contact with water. It may cause short circuit within the module.
- 6) Disconnect the AC power when replacing the backlight (CCFL) or inverter circuit. (High voltage occurs at the inverter circuit at 650Vrms)
- 7) Always clean the LCD panel with a soft cloth material.
- 8) Use care when handling the wires or connectors of the inverter circuit. Damaging the wires may cause a short circuit.
- 9) Protect the panel from ESD to avoid damaging the electronic circuit (C-MOS).
- 10) During the repair, DO NOT leave the Power On or Burn-in period for more than 1 hour while the TV is face down on a cloth.

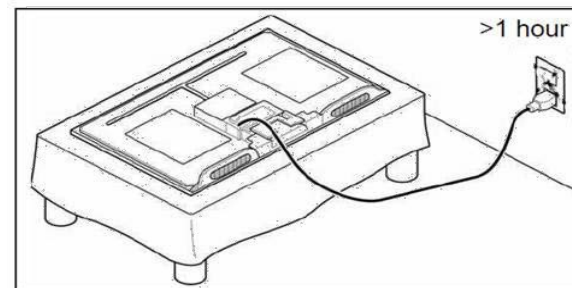

Figure 1. TV is faced down on a cloth during repair.

### 1-3. Caution About the Lithium Battery

1) Danger of explosion if battery is incorrectly replaced. Replace only with the same or equivalent type.

2) Outer case broken battery should not contact to water.

### 1-4. Safety Check-Out

After correcting the original service problem, perform the following safety checks before releasing the set to the customer:-

1) Check the area of your repair for unsoldered or poorly soldered connections. Check the entire board surface for solder splashes and bridges.

2) Check the inter board wiring to ensure that no wires are pinched or contact high-wattage resistors.

3) Check all control knobs, shields, covers, ground straps and mounting hardware have been replaced. Be absolutely certain you have replaced all the insulators.

4) Look for unauthorized replacement parts, particularly transistors that were installed during a previous repair. Point them out to the customer and recommend their replacement.

5) Look for parts which, though functioning show obvious signs of deterioration. Point them out to the customer and recommend their replacement.

6) Check the line cords for cracks and abrasion. Recommend the replacement of any such line cord to the customer.

7) Check the antenna terminals, metal trim, metalized knobs, screws and all other exposed metal parts for AC leakage. Check leakage test as described next.

8. For safety reasons, repairing the Power board and/or Inverter board is prohibited.

### 1-5. Leakage Test

The AC leakage from any exposed metal part to earth ground and from all exposed metal parts to any exposed metal part having a return to chassis must not exceed 0.5mA (500 microamperes).

Leakage current can be measured by any one of the three methods:-

1) A commercial leakage tester such as the SIMPSON 229 or RCA WT540A. Follow the manufacturers instructions to use those instructions.

2) A battery-operated AC milliammeter The DATA PRECISION 245 digital multimeter is suitable for this job.

3) Measuring the voltage drop across a resistor by means of a VOM or battery operated AC voltmeter. The 'limit' indication is 0.75V so analog meters must have an accurate low voltage scale. The SIMPSON'S 250 and SANWA SH-63TRD are examples of passive VOMs that are suitable. Nearly all battery operated digital multimeter that have a 2 VAC range are suitable. (see Figure 2.)

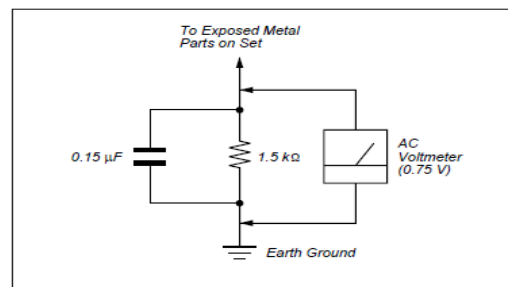

Figure 2. AC voltmeter to check AC leakage

### 1-6. How to Find a Good Earth Ground

1) A cold-water pipe is a guaranteed earth ground; the cover-plate retaining screw on most AC outlet boxes is also at earth ground.

2) If the retaining screw is to be used as your earth ground, verify that it is at ground by measuring the resistance between it and a cold-water pipe with an ohmmeter. The reading should be zero ohms.

3) If a cold-water pipe is not accessible, connect a 60- to 100-watt trouble-light (not a neon lamp) between the hot side of the receptacle and the retaining screw. Try both slots, if necessary, to locate the hot side on the line; the lamp should light at normal brilliance if the screw is at ground potential (see Figure 3).

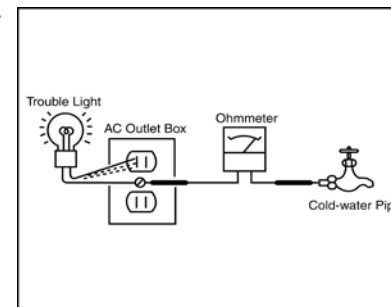

Figure B. Checking for earth ground.

Figure 3. Checking for earth ground.

### 1-7. Lead Free Information

The circuit boards used in these models have been processed using Lead Free Solder. The boards are identified by the LF logo located close to the board designation.



Figure 4: LF Logo

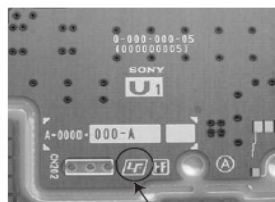
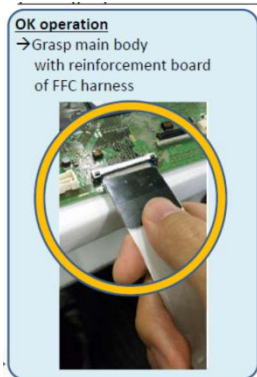

Figure 5: LF logo on circuit board

The servicing of these boards requires special precautions. It is strongly recommended to use Lead Free Solder material in order to guarantee optimal quality of new solder joints.

### 1-8. Handling the FLEXIBLE FLAT CABLE (FFC)

- When you insert / pull out FFC, please grasp a reinforcement board and main body of FFC.



<GOOD>



<NG>

Please hold reinforcement board and plunge it to depths.

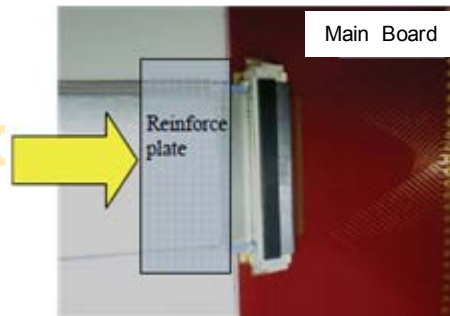

< Insertion >

Please pull out FFC while pushing the button of both ends at the same time.

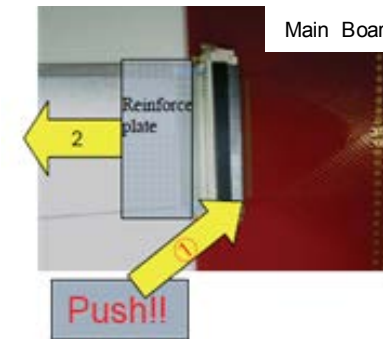

< Pull out >

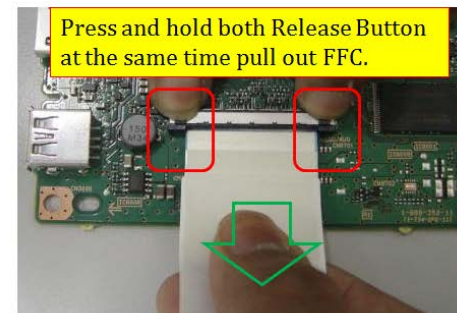
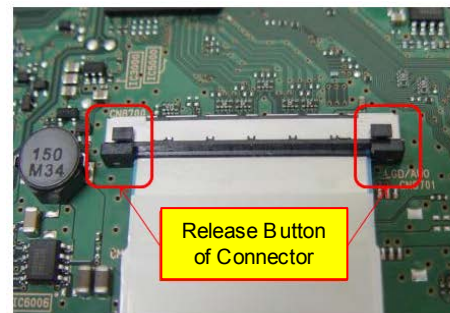

FFC connector broken if pull out FFC without press and hold both Release Button of connector. Symptom 5X blinking will be appear due to improperly seated.

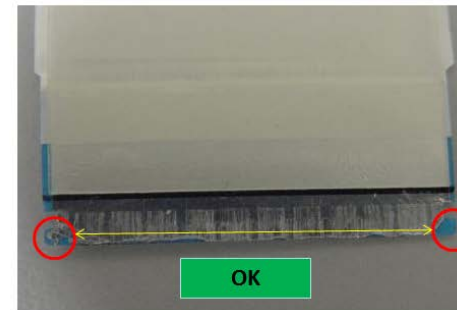

## SECTION 2 SELF DIAGNOSTIC FUNCTION

### 2-1. Overview of Control Buttons

#### 2-1-1.

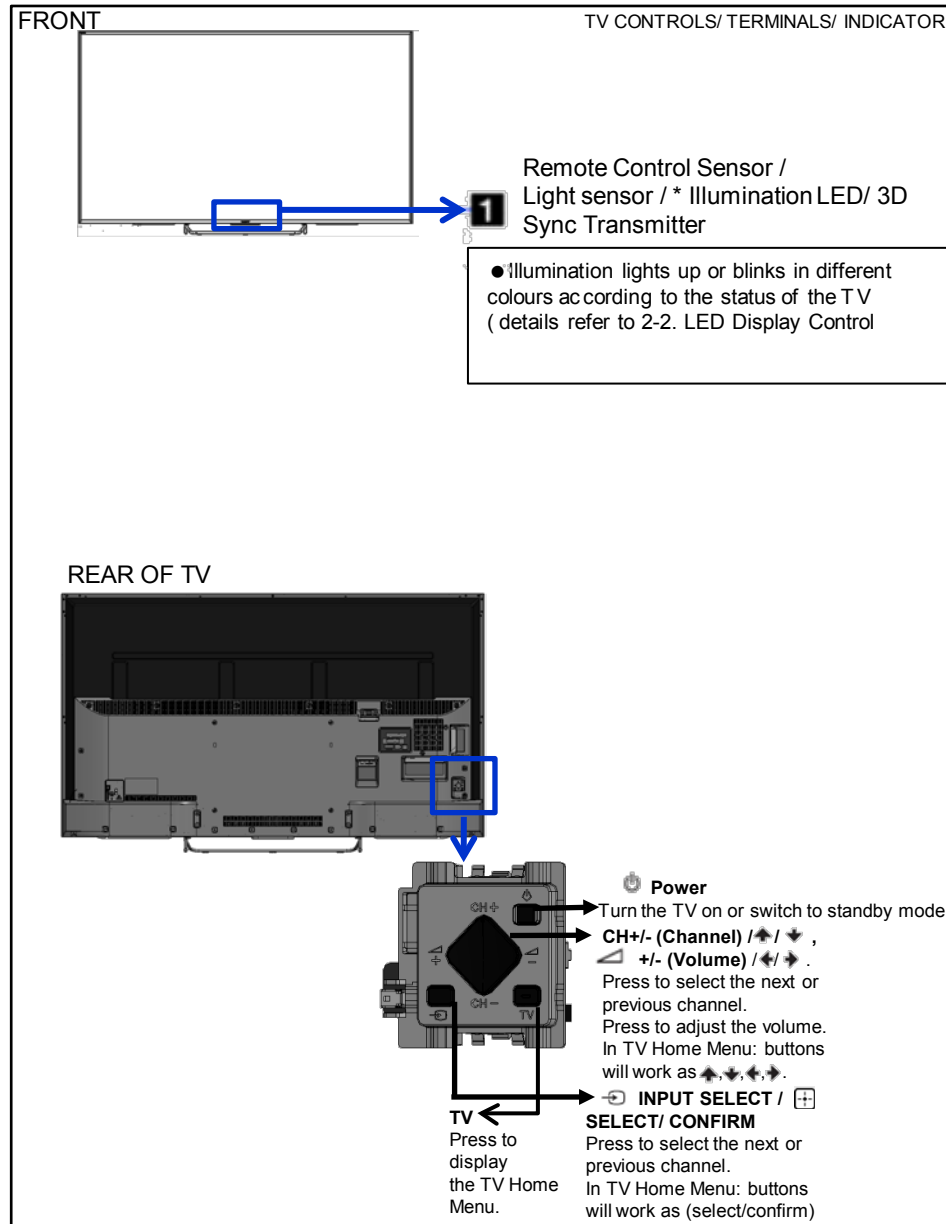



### 2-2. LED Display Control

Status	White Center LED	Side RGB LED	Side Amber LED	Remarks
Power Off ( by power saving switch off and *1)	Off	Off	Off	*1 power switch off (by side key)
Power On	White	Off	Off	
STBY/i.LINK STBY/PC STBY ( by remote control of f only )	Off	Off	Off	
Picture Off	White looping	White one shot	Off	
Device Connection	White	Cyan one s hot	Off	
Power ON Animation	White	White one shot	Off	
Sleep Timer/On Timer/Reminder/REC Timer/Photo Frame ( Power On )	White	Amber One shot -> Lit*2	Off	*2 One Shot is only user action.
On Timer/Reminder/REC Timer ( Deep Standby )	Off	Off	Amber	After 5 minutes, side amber LED On
Self Diagnosis	Off	Red Blinking	Off	The number of LED blinking indicates cause of failure ( refer to Led Error / Triage chart)
Aging mode	White	Green Blinking	Off	Blinking:0.5sec On / 0.5sec Off
Software U pdating	white blinking	white blinking	off	
Software Updating finish	White	Blue lit	off	
Test Reset	White	white blinking	Amber blinking	
Error of panel ID	White	Green / Amber Blinking	Off	Blinking:0.5sec On / 0.5sec Off
REC (SCART REC & HDD REC/LIVE PAUSE) [AEP/J only]	White	Red(Pink) One shot -> Lit*2	Off	*2 One Shot is only user action.
ePOP/ Shop Illumination	White	Cyan loop	Off	One shot Center White when feature change

### 2-3. LED Pattern

When safety shutdown occurs, Standby LED display reports the cause by using the lightning patterns as indicated below.

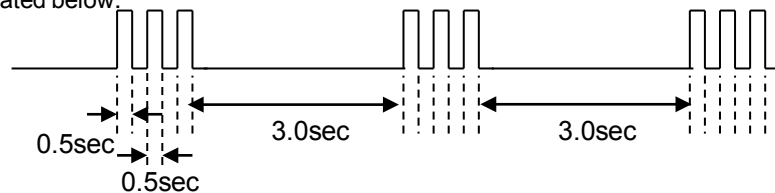

Example: The figure above shows LED display when SHUTDOWN is caused by Audio Error. It repeats flashing for a specified number of times in 0.5sec/cycle and has a 3 seconds interval of lighting off. Please note that a 3 seconds interval of lighting off is fixed regardless of abnormal state types.

### 2-4. Standby LED Error Display

Smart Core RED LED blinking count	Detection Items	Board Error Item
2x	Main 12V failure [MAIN_POWE] * This failure is not saved	<ul style="list-style-type: none"> <li>G** Board Error</li> <li>BMX Board Error</li> </ul>
3x	Main 5.0V failure [DC_ALERT]	<ul style="list-style-type: none"> <li>BMX Board Error</li> </ul>
	Audio amp. protection [AUD_ERR]	<ul style="list-style-type: none"> <li>BMX Board Error</li> <li>Speaker</li> </ul>
5x	<del>Tuner or demodulator I2C NACK [TU_DEMOD]</del>	<del>BMX Board Error</del>
	Panel ID EEPROM I2C NACK (Also panel power failure is a suspect) [P_ID_ERR] (*detect at startup sequence only)	<ul style="list-style-type: none"> <li>Panel module</li> <li>Tcon board</li> <li>G** Board Error</li> <li>BMX Board Error</li> </ul>
	FRC device I2C No ACK [FRCTC_I2C]	<ul style="list-style-type: none"> <li>Tcon board</li> </ul>
6x	FRC device Initialization failure [FRCTC_I2C] (*detect at startup sequence only)	<ul style="list-style-type: none"> <li>Tcon board</li> </ul>
	Backlight failure [BACKLIGHT]	<ul style="list-style-type: none"> <li>G** Board Error</li> <li>Panel module</li> <li>BMX Board Error</li> </ul>
7x	Over temperature protection [TEMP_ERR] Temp. sensor I2C NACK [TEMP_ERR]	<ul style="list-style-type: none"> <li>BMX Board Error</li> </ul>

Size	G* Board Type
65"	GL1SB
75"	GL1C

## 2-5. Triage Chart

Reference	Symptoms - Shutdown. Power LED blinking red diagnostics sequences									No Power	Video - missing or distorted			Remote	Network	Audio	Skype	Smart Core	Bluetooth (BT)
	2	3	4	5	6	7	8	9	10	No White Power LED & does not response to remote (Dead Set)	Stationary coloured lines or dots	No video One of Inputs	No video all Inputs	No Remote	Wireless can't connect	No Audio	Skype Can't Work	Smart Core no LED (Set is still alive)	Bluetooth / One Step Remote (OSR) can't connect
BAX Board	▲	●		▲	▲	●	●			▲	▲	●	●	▲	▲	●	▲	▲	▲
G* Board	●	▲		▲	●					●						▲			
H* Board									●					●				●	
Speaker		▲														●			
Wifi & BT Module							●								●		▲		●
LD Board			●										▲						
LVDS FFC				▲	▲						▲		▲						
Tcon			▲	●	▲						▲		▲						
LCD Panel			●	●	●	▲					●		▲						
Problem	Power	Power	LD	Panel (Tcon)	Panel (Backlight)	TEMP	Software		Emitter										
		Audio				FAN (N/A)													
		Local I2C																	

- Most likely defective part
- ▲ Secondary possible defective part
- Not Applicable

Size	B* Board	G* Board	H* Board
65"	BMX	GL1SB	HSC3_L
75"	BMX	GL1C	HSC3_L

## SECTION 3 TROUBLESHOOTING

### 3-1. NO POWER

#### 3-1-1 NO POWER (XMH-65)

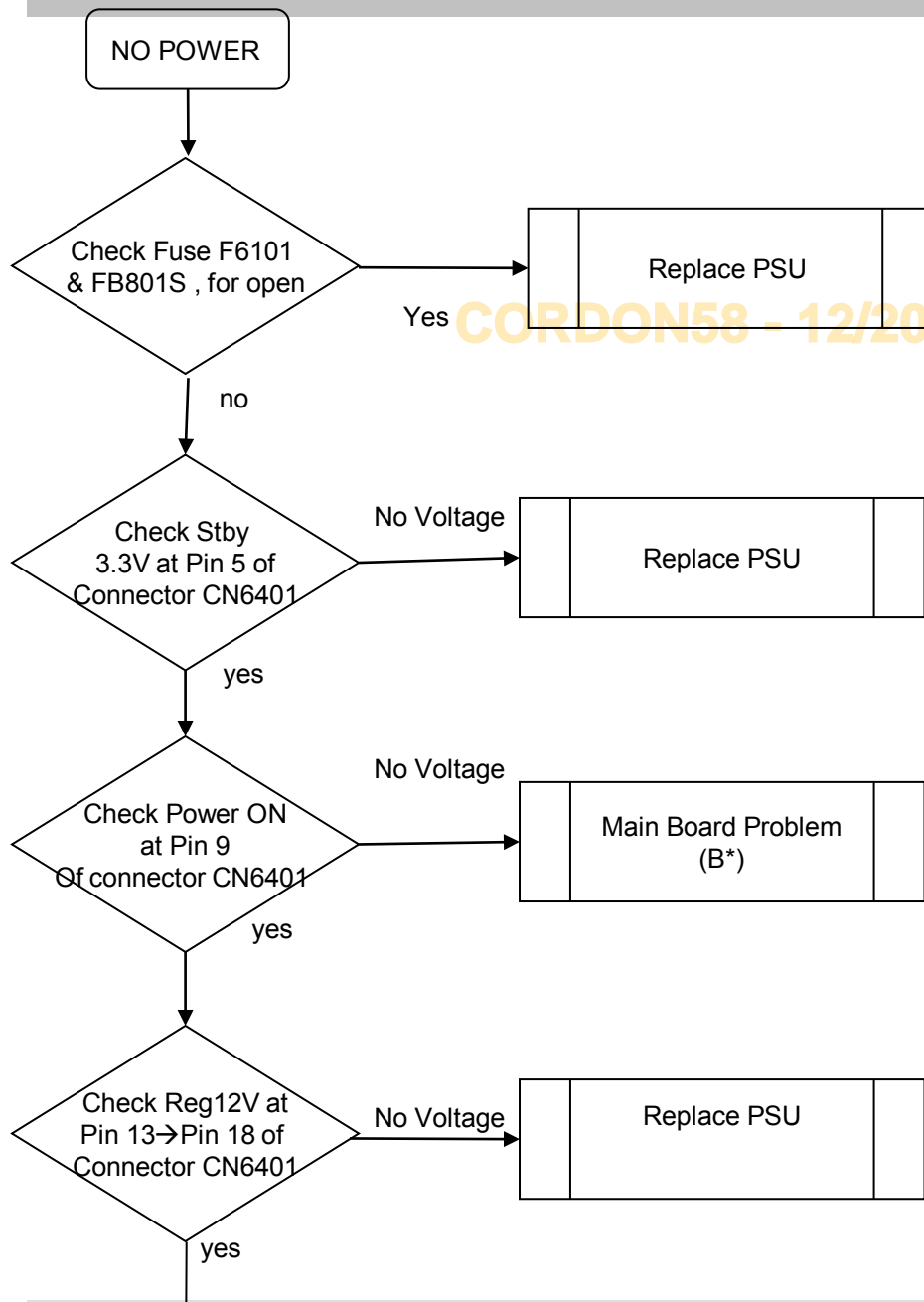

Size	B* Board	G* Board	H* Board
65"	BMX	GL1SB	HSC3_L
75"	BMX	GL1C	HSC3_L

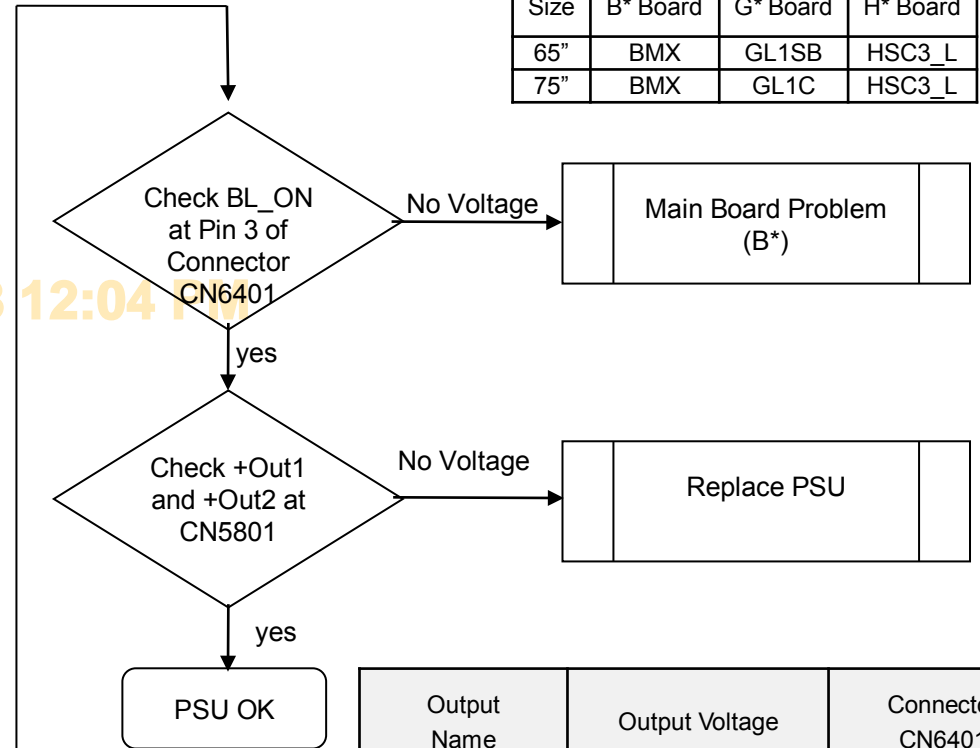

Output Name	Output Voltage	Connector CN6401
BL_ON	2.64V~3.3V	Pin 3
STBY3.3V	3.35V~3.55V	Pin 5
AC OFF DET	3.45V	Pin 7
BL_ERR	0V	Pin 8
Power_ON	2.64V~3.3V	Pin 9
REG12V	12.2V~13.2V	Pin 13->Pin 18

Output Name	Output Voltage	Connector CN5801
+OUT1	173.6V~250.3V	Pin 1
+OUT2	173.6V~250.3V	Pin 2

### 3-1-2 NO POWER (XMH-75)

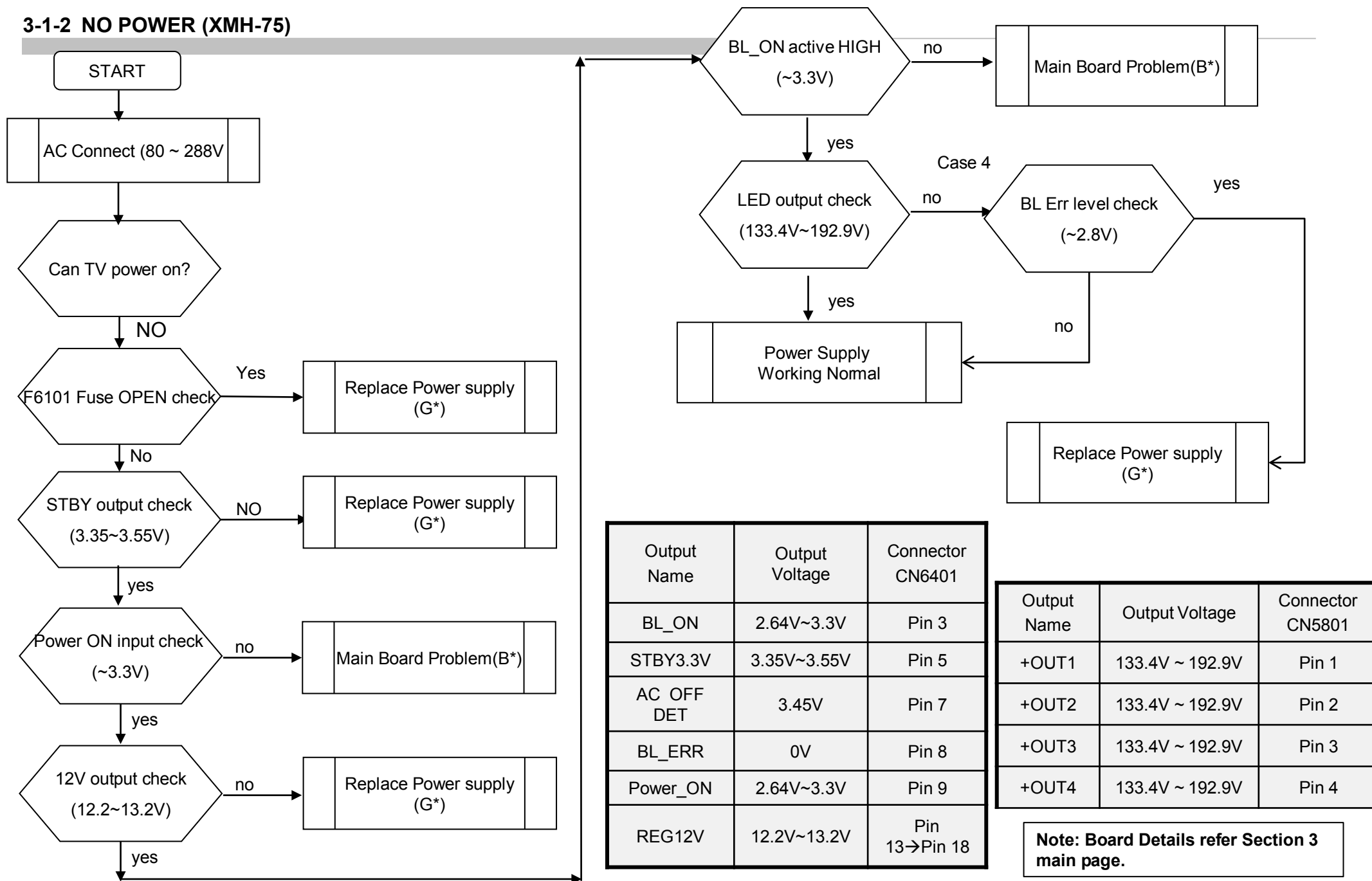

Output Name	Output Voltage	Connector CN6401
BL_ON	2.64V~3.3V	Pin 3
STBY3.3V	3.35V~3.55V	Pin 5
AC OFF DET	3.45V	Pin 7
BL_ERR	0V	Pin 8
Power_ON	2.64V~3.3V	Pin 9
REG12V	12.2V~13.2V	Pin 13→Pin 18

Output Name	Output Voltage	Connector CN5801
+OUT1	133.4V ~ 192.9V	Pin 1
+OUT2	133.4V ~ 192.9V	Pin 2
+OUT3	133.4V ~ 192.9V	Pin 3
+OUT4	133.4V ~ 192.9V	Pin 4

**Note: Board Details refer Section 3 main page.**

### 3-1-3 No POWER - DC/DC converter check

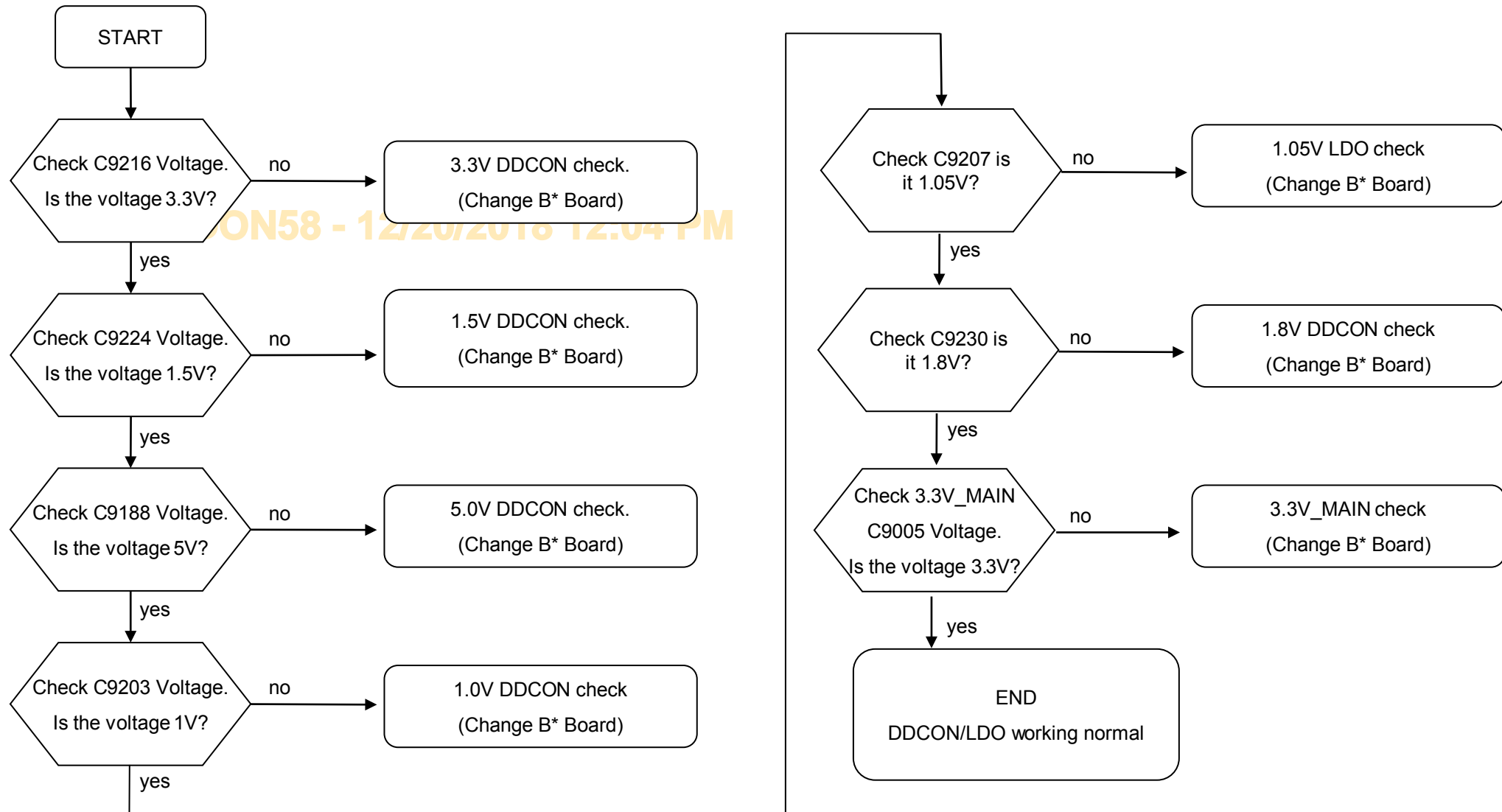

**Note: Board Details refer Section 3 main page.**

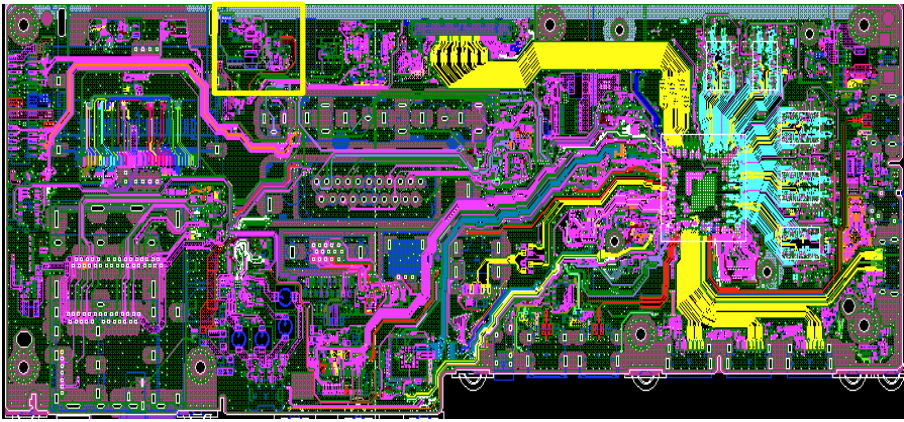
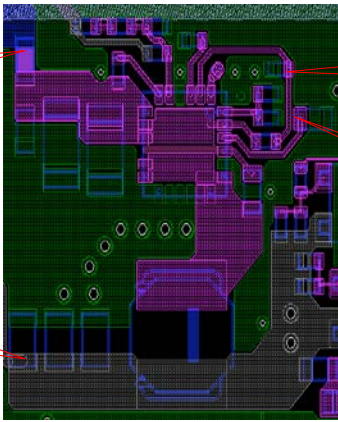
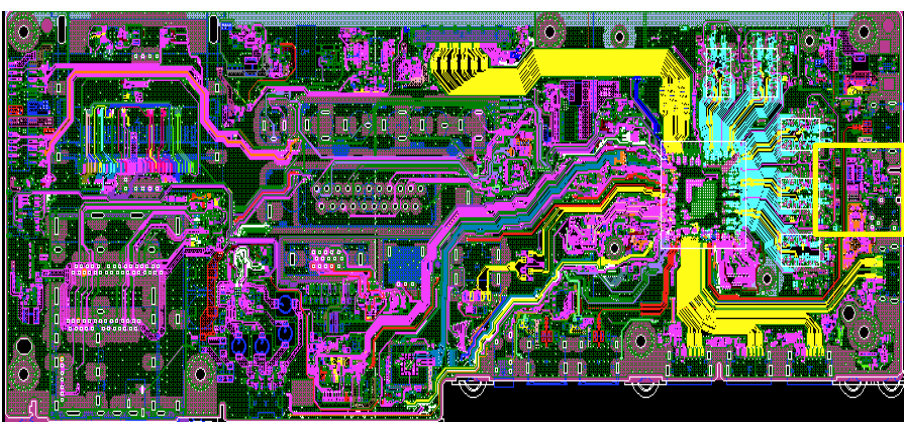
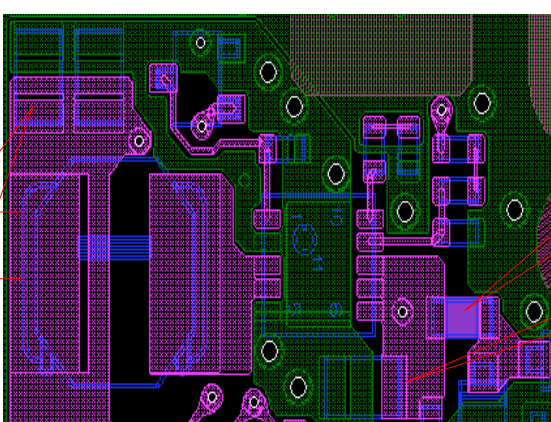
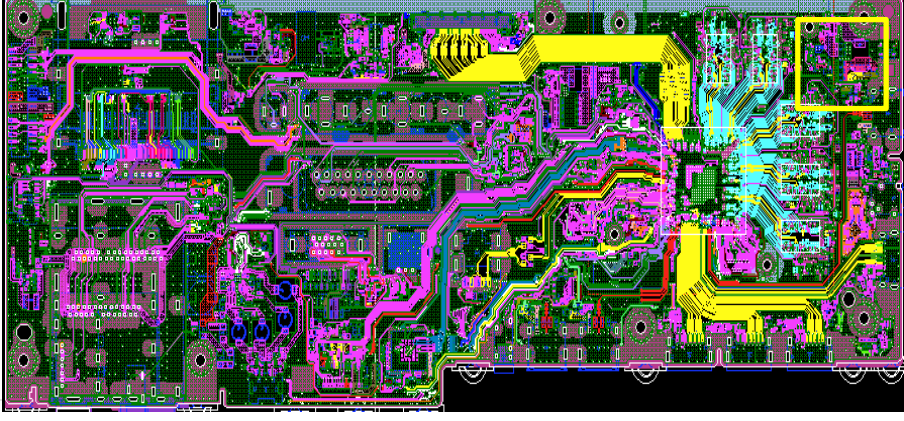
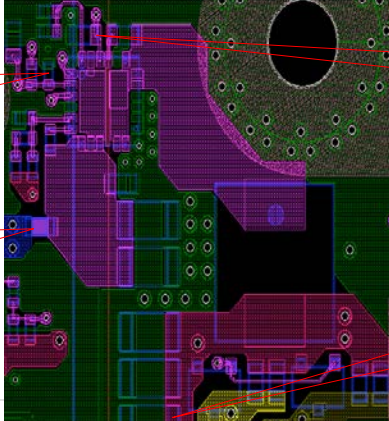

BMX	Board PWB (A side)	Detail
3.3V		 <p>F9015</p> <p>R9321</p> <p>C9213</p> <p>C9216</p>
1.5V		 <p>C9224</p> <p>F9016</p> <p>C9222</p>
5.0V		 <p>R9277</p> <p>F9013</p> <p>C9185</p> <p>C9188</p>

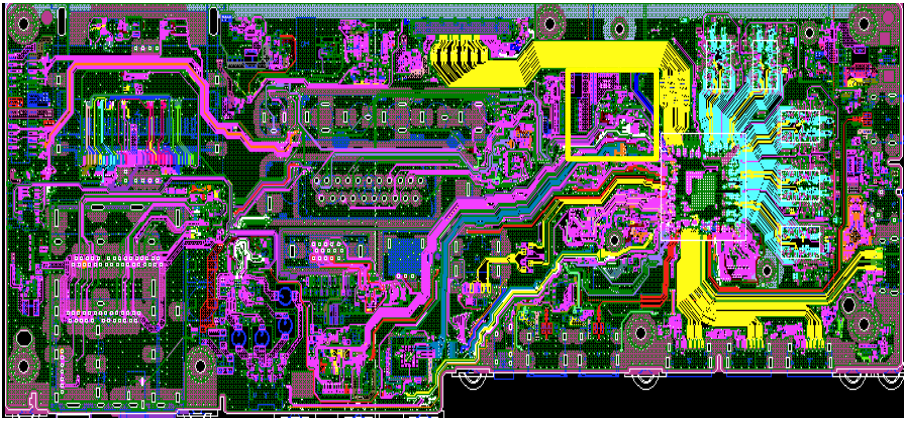
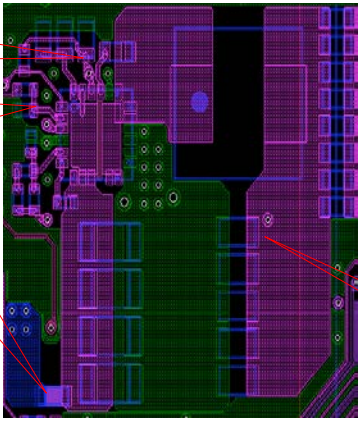
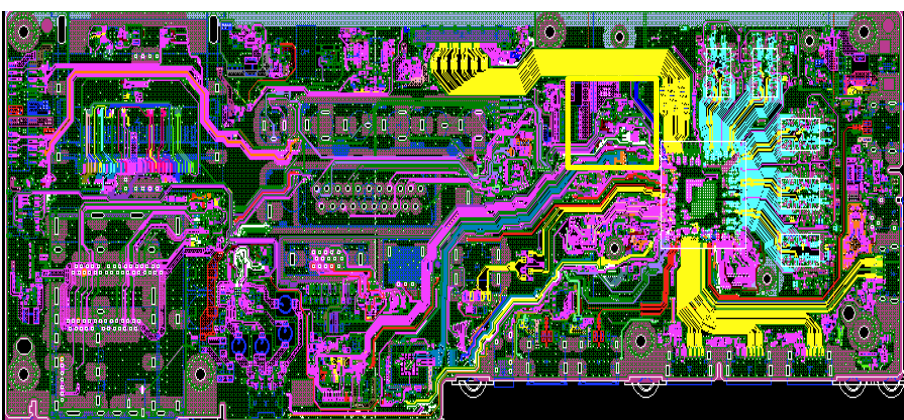
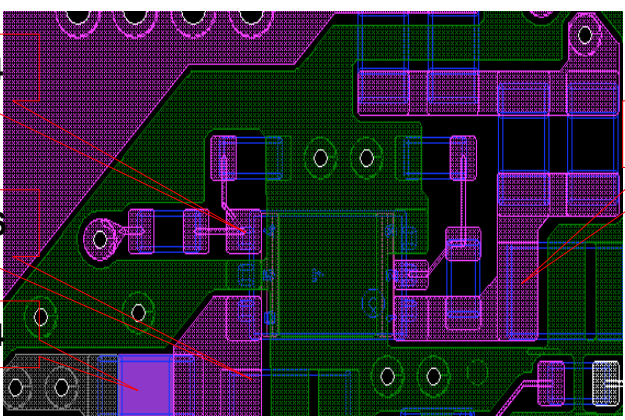
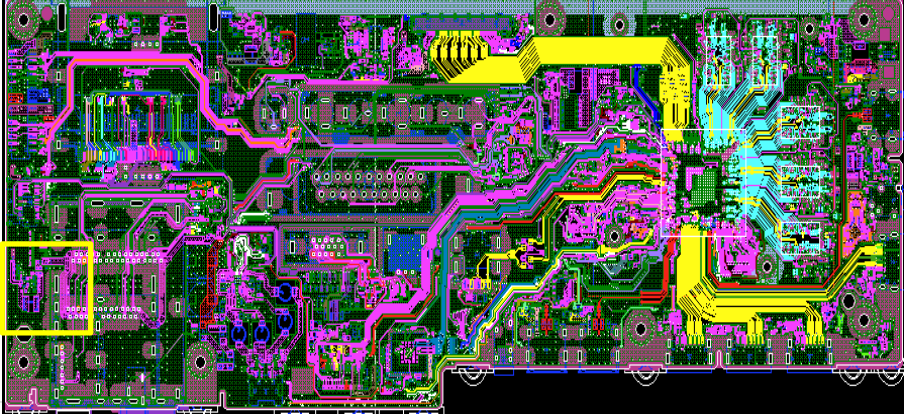
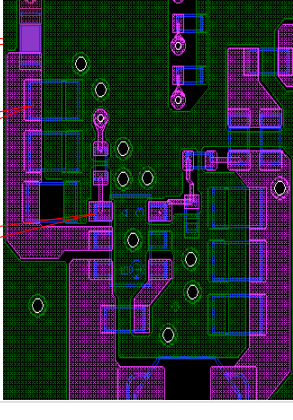

BMX	Board PWB (A side)	Detail
1.0V		 <p>C9169</p> <p>C9263</p> <p>F9012</p> <p>C9203</p>
1.05V		 <p>#PIN4</p> <p>C9206</p> <p>F9014</p> <p>C9207</p>
1.8V		 <p>F9017</p> <p>C9229</p> <p>#PIN4</p> <p>C9230</p>

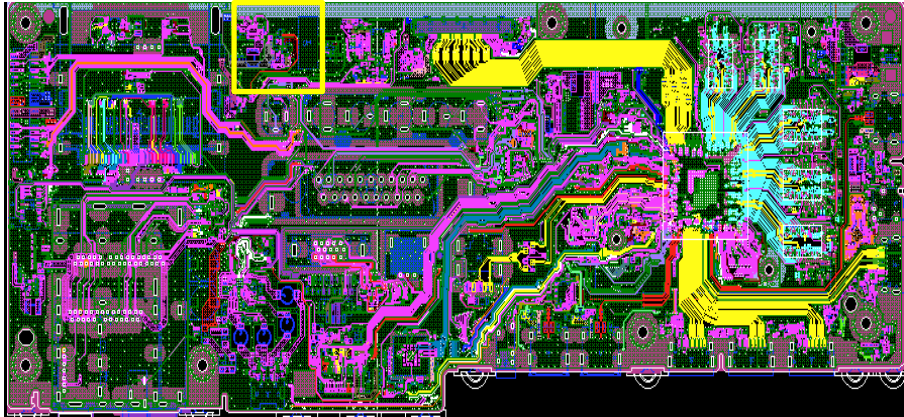
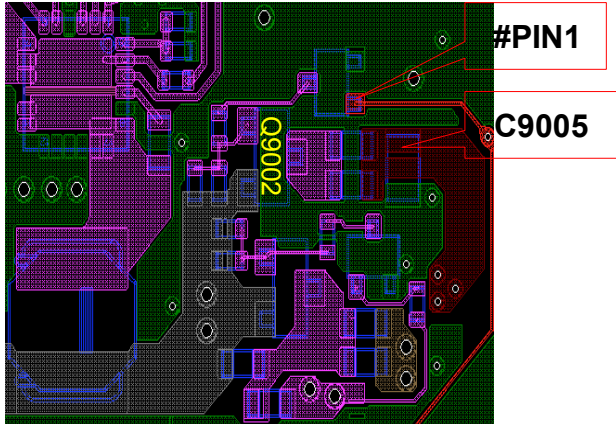
BMX	Board PWB (A side)	Detail
3.3V_MAIN		



### 3-1-4. NO POWER – Muffin Replacement (Main Device)

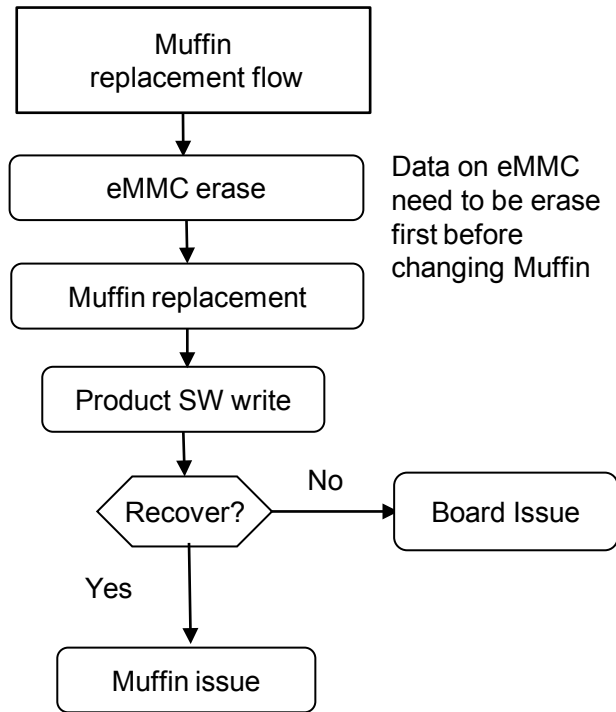

### 3-2. LED BLINKING

#### 3-2-1. LED Blinking: 2x (Main power Error)

BMX board (XM-H) only → G\* Board

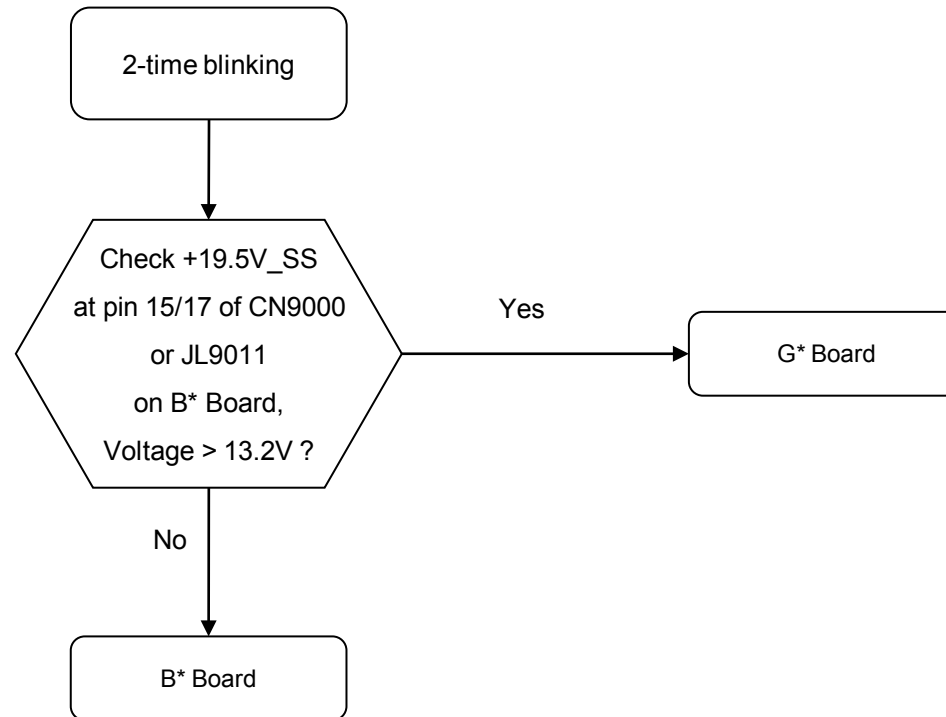

**Note: Board Details refer Section 3 main page.**

3-2-1. LED Blinking: 2x (Main power Error)

Troubleshooting References

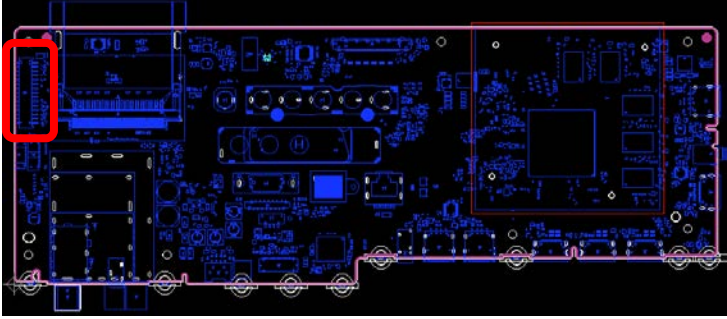
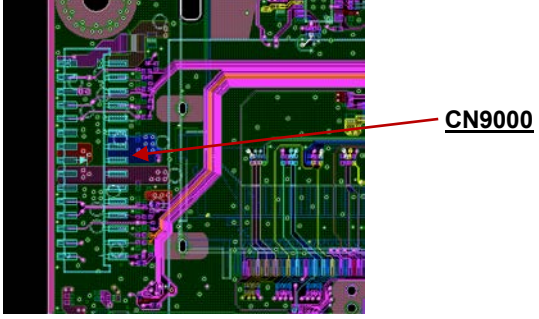
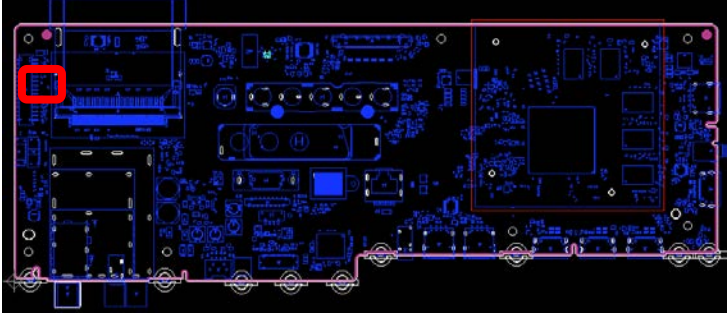
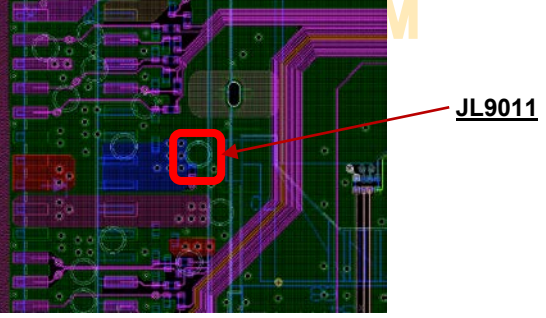
Board Name	Board PWB (A side)	Detail
BMX (CN9000)		
BMX (JL9011)		

### 3-2-2. LED Blinking: 3x (DC Alert & Communication Error)

BMX board (XM-H)

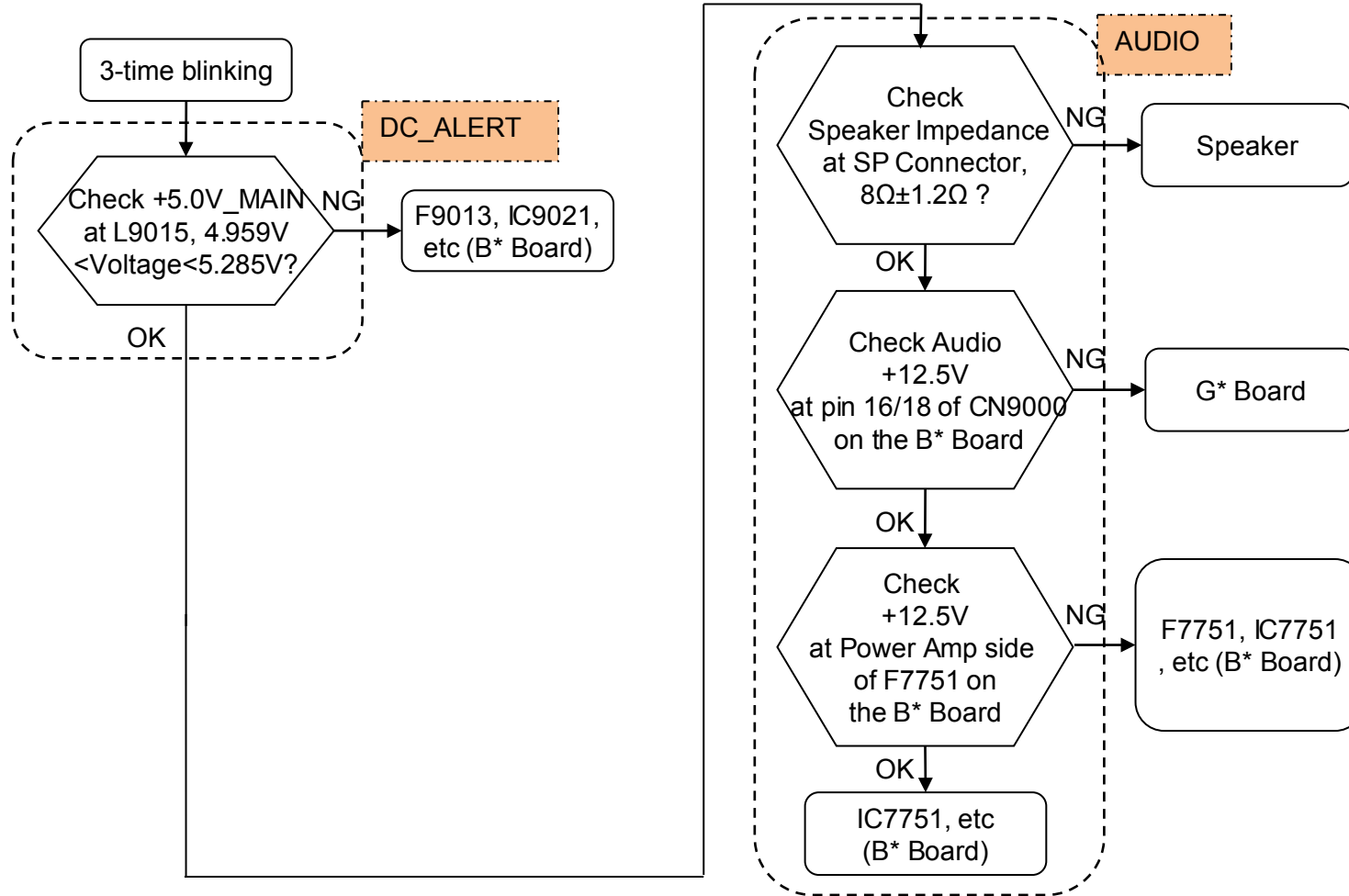

**3-2-2. LED Blinking: 3x (DC Alert & Communication Error)**

Troubleshooting References

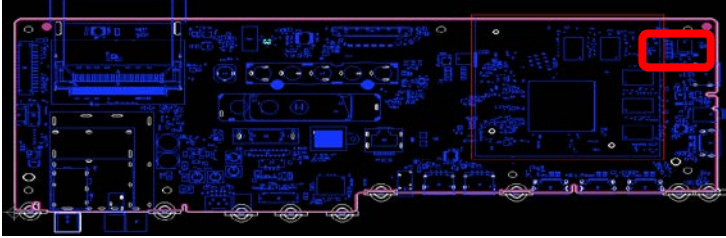
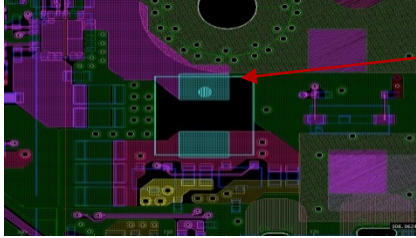
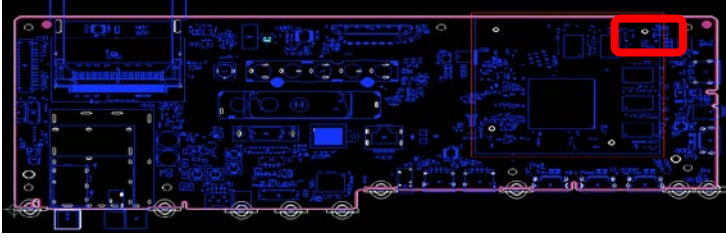
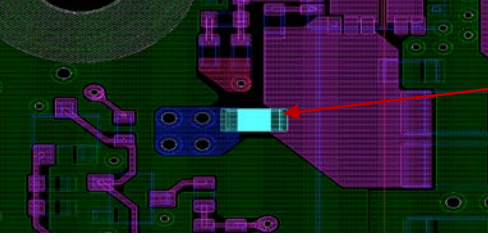
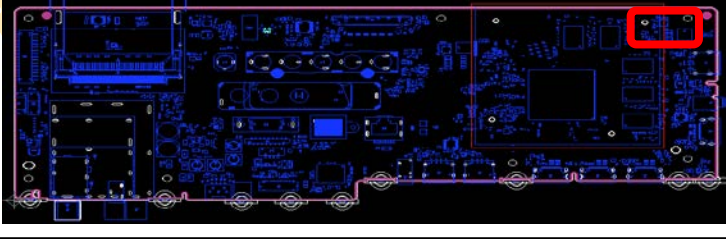
Board Name	Board PWB (A side)	Detail
BMX (L9015)		 <p><u>L9015</u></p>
BMX (F9103)		 <p><u>F9103</u></p>
BMX (IC9021)		 <p><u>IC9021</u></p>

**3-2-2. LED Blinking: 3x (DC Alert & Communication Error)**

Troubleshooting References

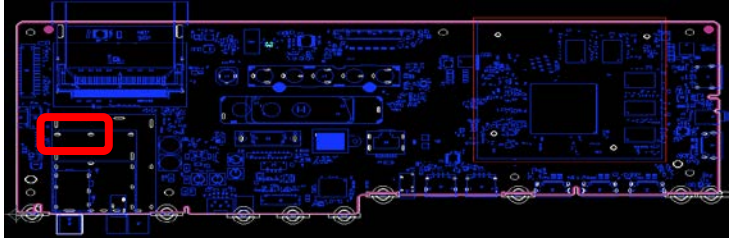
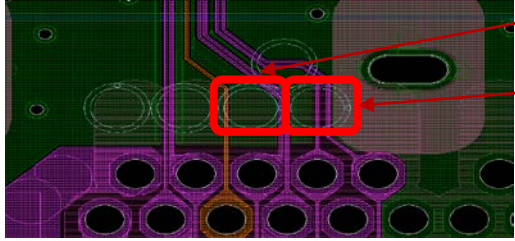
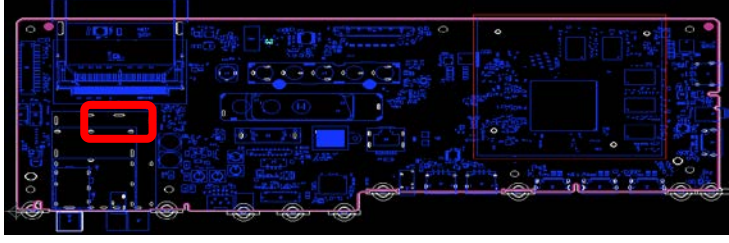
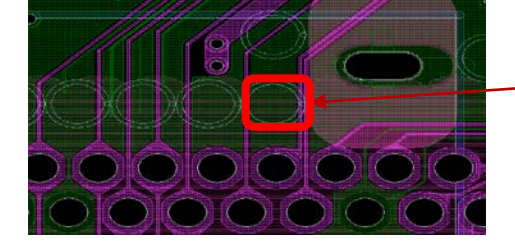
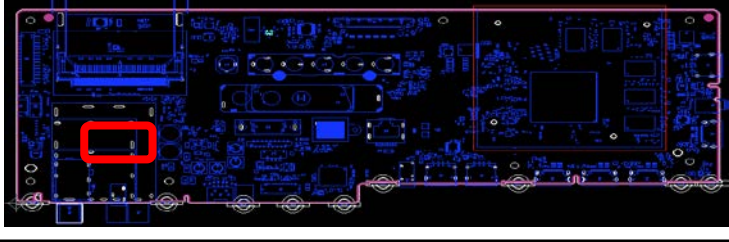
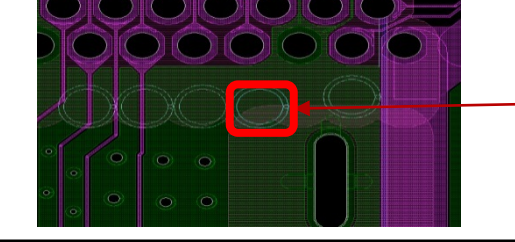
Board Name	Board PWB (A side)	Detail
BMX (JL6010, JL6011)		 <p data-bbox="1653 488 1742 512"><u>JL6010</u></p> <p data-bbox="1653 560 1742 584"><u>JL6011</u></p>
BMX (JL6021)		 <p data-bbox="1653 823 1742 847"><u>JL6021</u></p>
BMX (JL6022)		 <p data-bbox="1653 1110 1742 1134"><u>JL6022</u></p>



### 3-2-2. LED Blinking: 3x (DC Alert & Communication Error)

#### Troubleshooting References

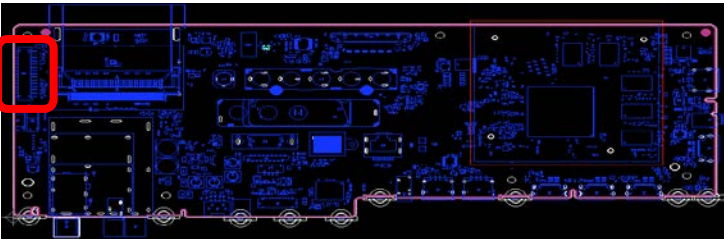
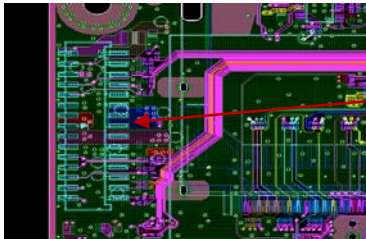
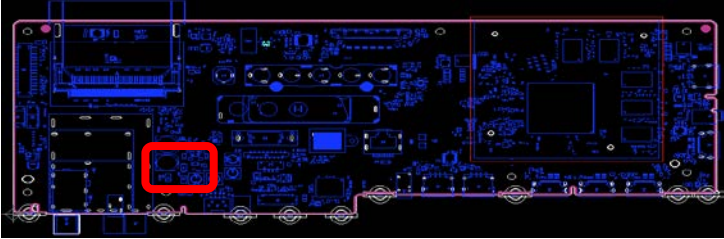
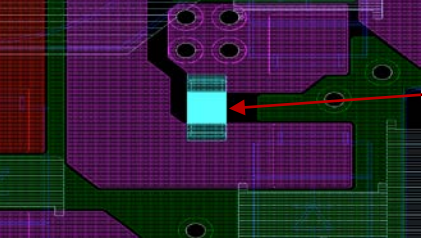
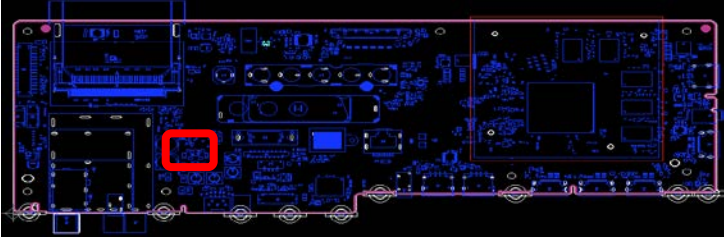
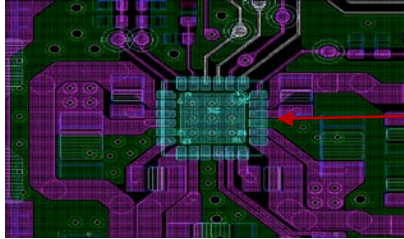
Board Name	Board PWB (A side)	Detail
BMX (CN9000)		 <p data-bbox="1626 496 1715 520"><u>CN9000</u></p>
BMX (F7751)		 <p data-bbox="1653 767 1727 791"><u>F7751</u></p>
BMX (IC7751)		 <p data-bbox="1664 1046 1742 1070"><u>IC7751</u></p>

3-2-3. LED BLINKING 5x (Panel Communication Error) – a) 12.5V NG

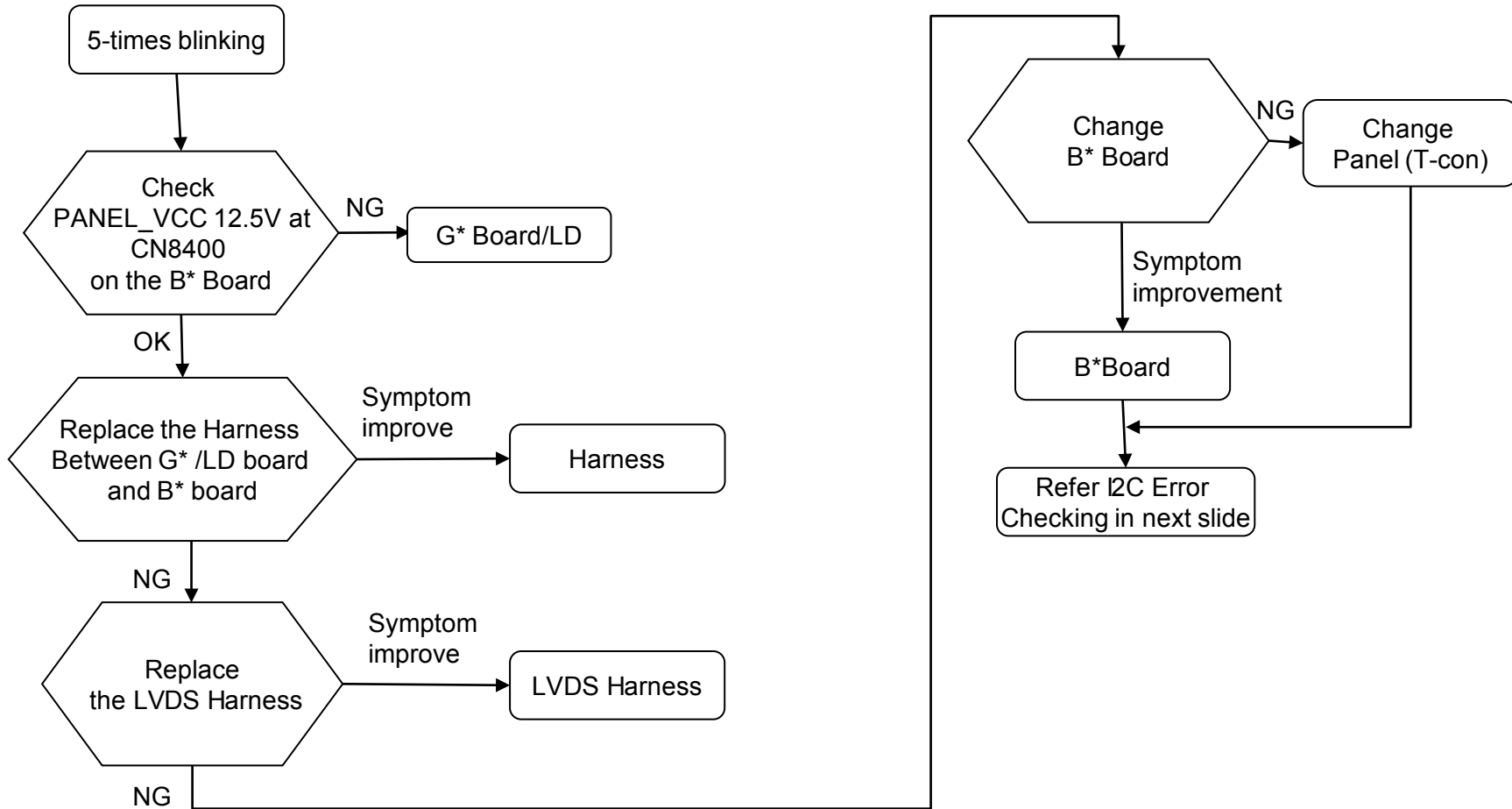

**Note: Board Details refer Section 3 main page.**



**3-2-3. LED BLINKING 5x (Panel Communication Error) – b) I2C Error**

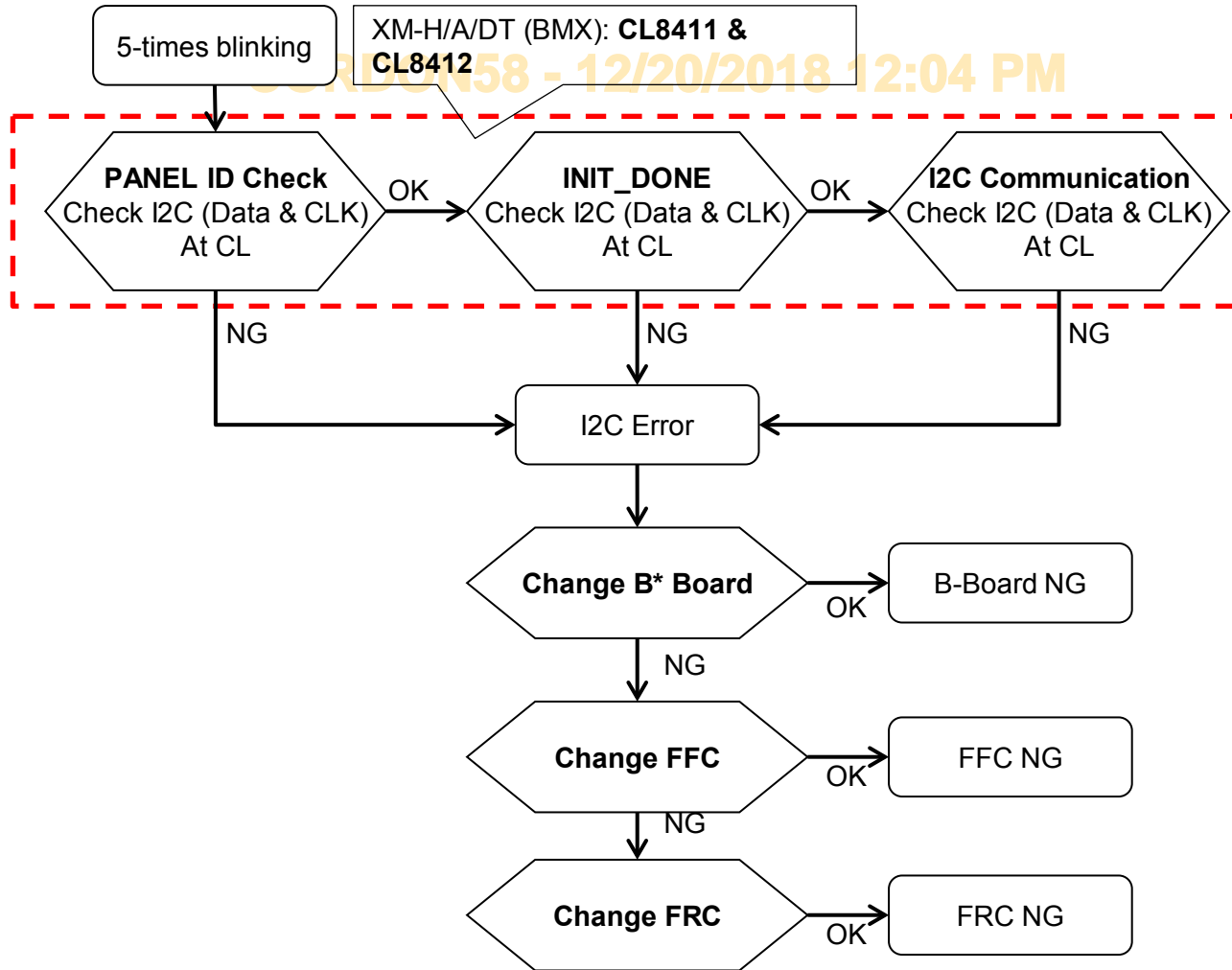

## BMX Probing Points – I2C Line Check

**BMX (A-Side)**

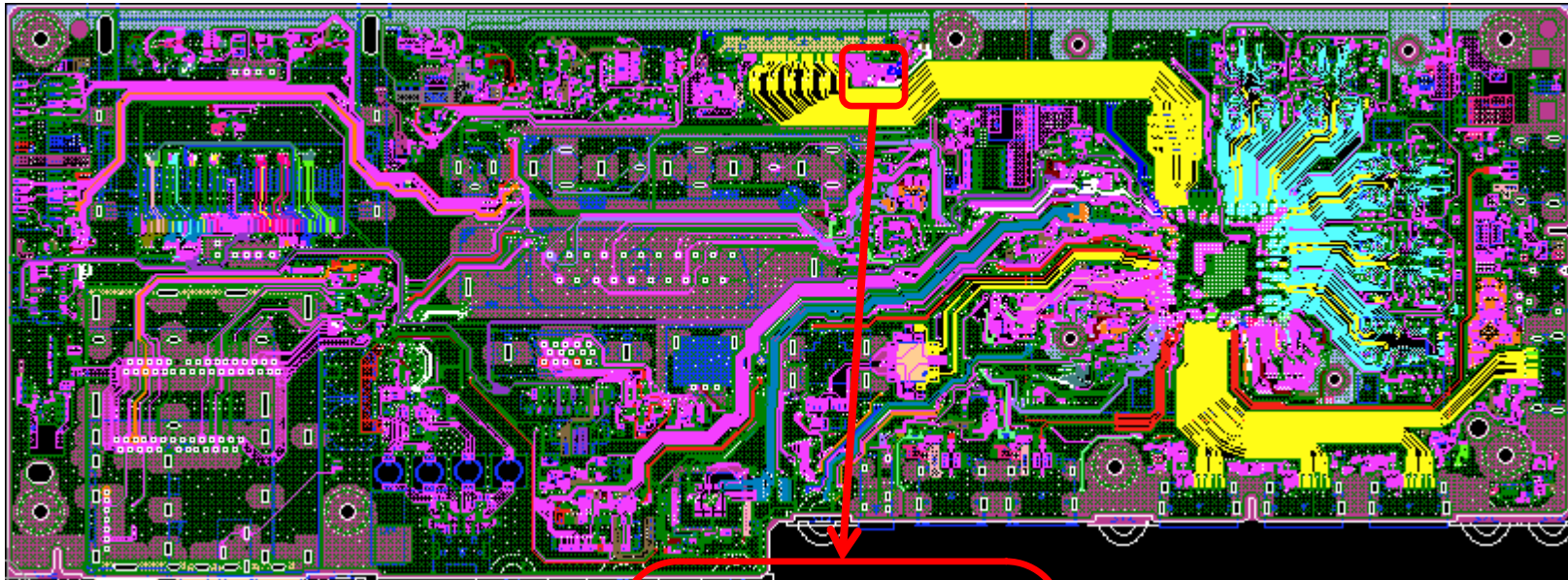

CL8411  
(I2C\_S\_DATA)

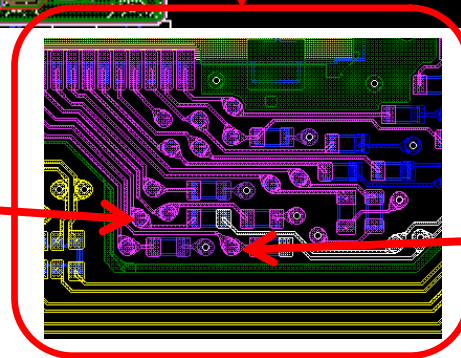

CL8412  
(I2C\_S\_CLOCK)

### 3-2-4. LED BLINKING 6x (Backlight Error)

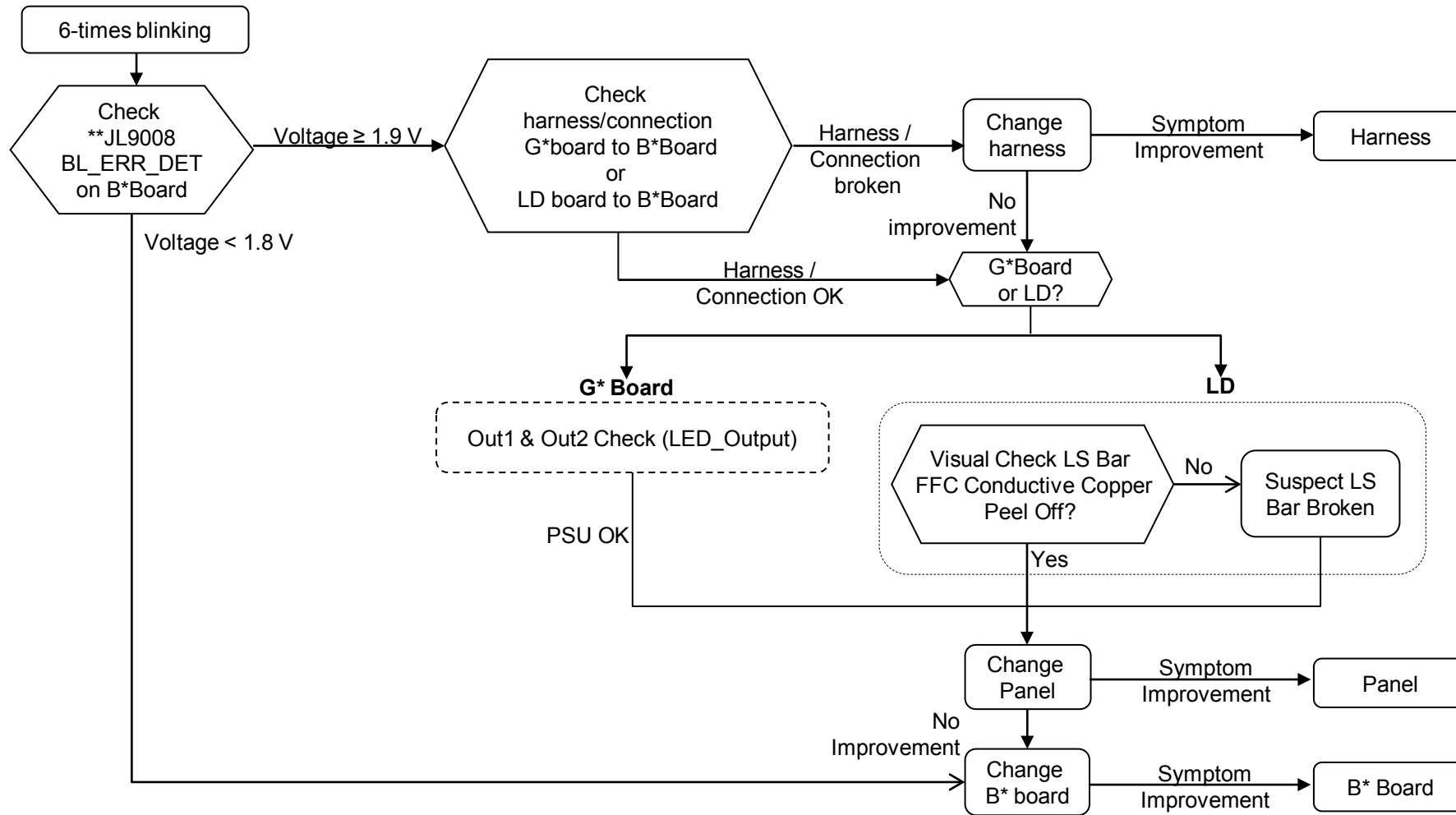

\*\*BMX: JL9008 BL\_ERR\_DET

**Note: Board Details refer Section 3 main page.**

### 3-2-4. LED BLINKING 6x (Backlight Error)

BMX: B Side

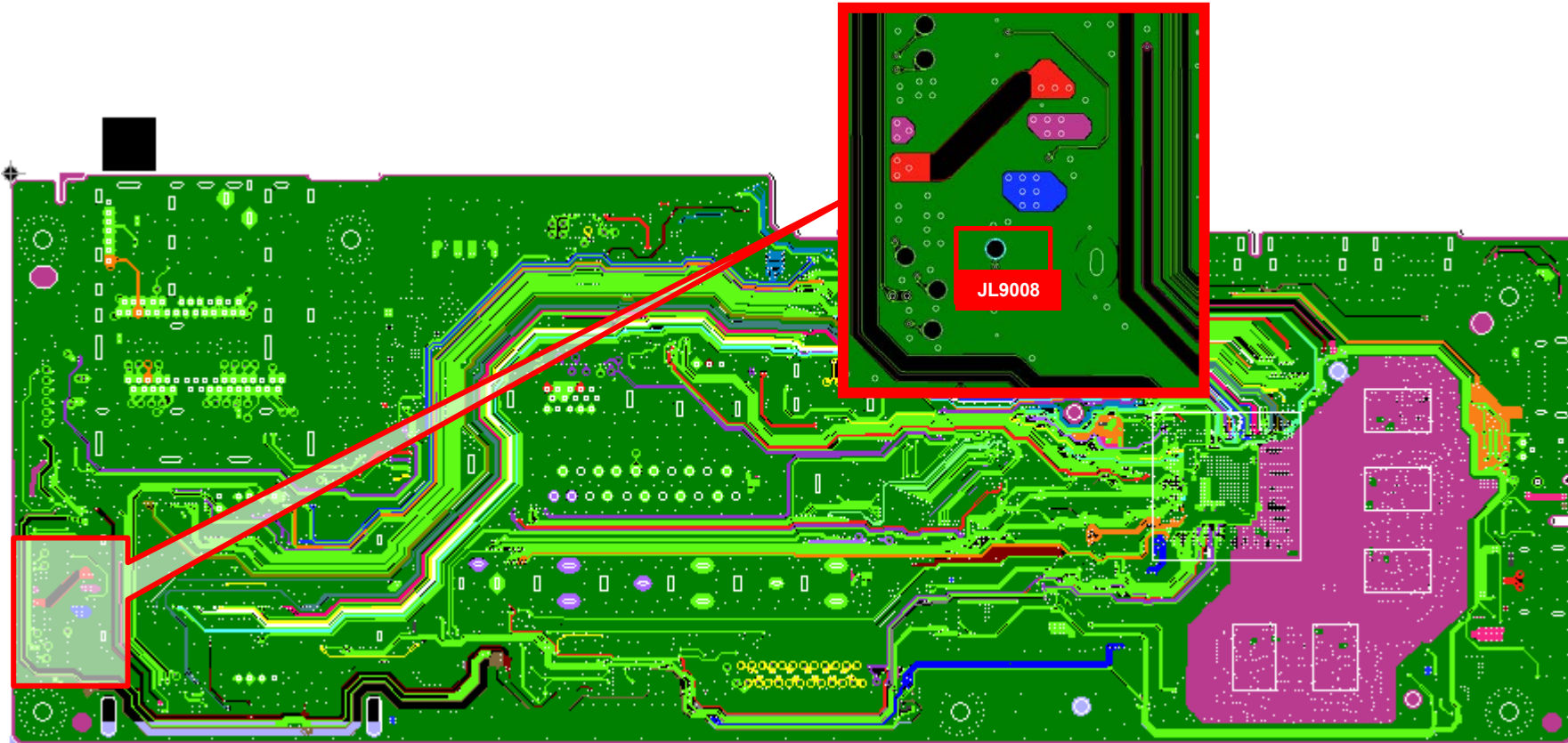

### 3-2-5. LED BLINKING 7x (Temperature Error)

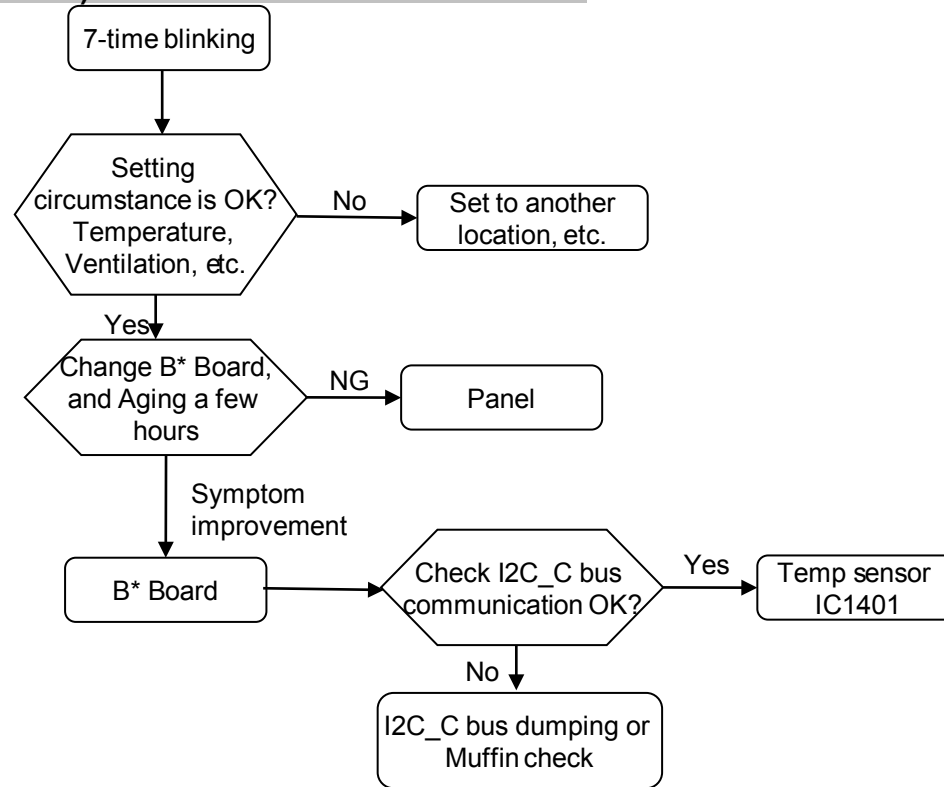

Troubleshooting Reference

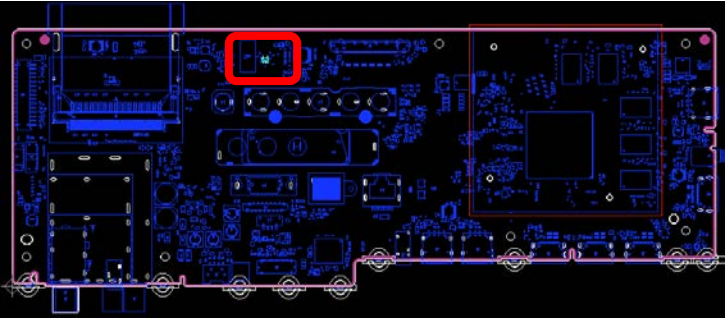
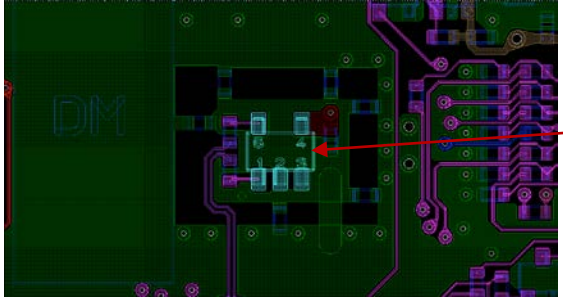
Board Name	Board PWB (A side)	Detail
BMX (IC1401)		 <p data-bbox="1854 1273 1944 1300"><b>IC1401</b></p>

### 3-3. No Sound

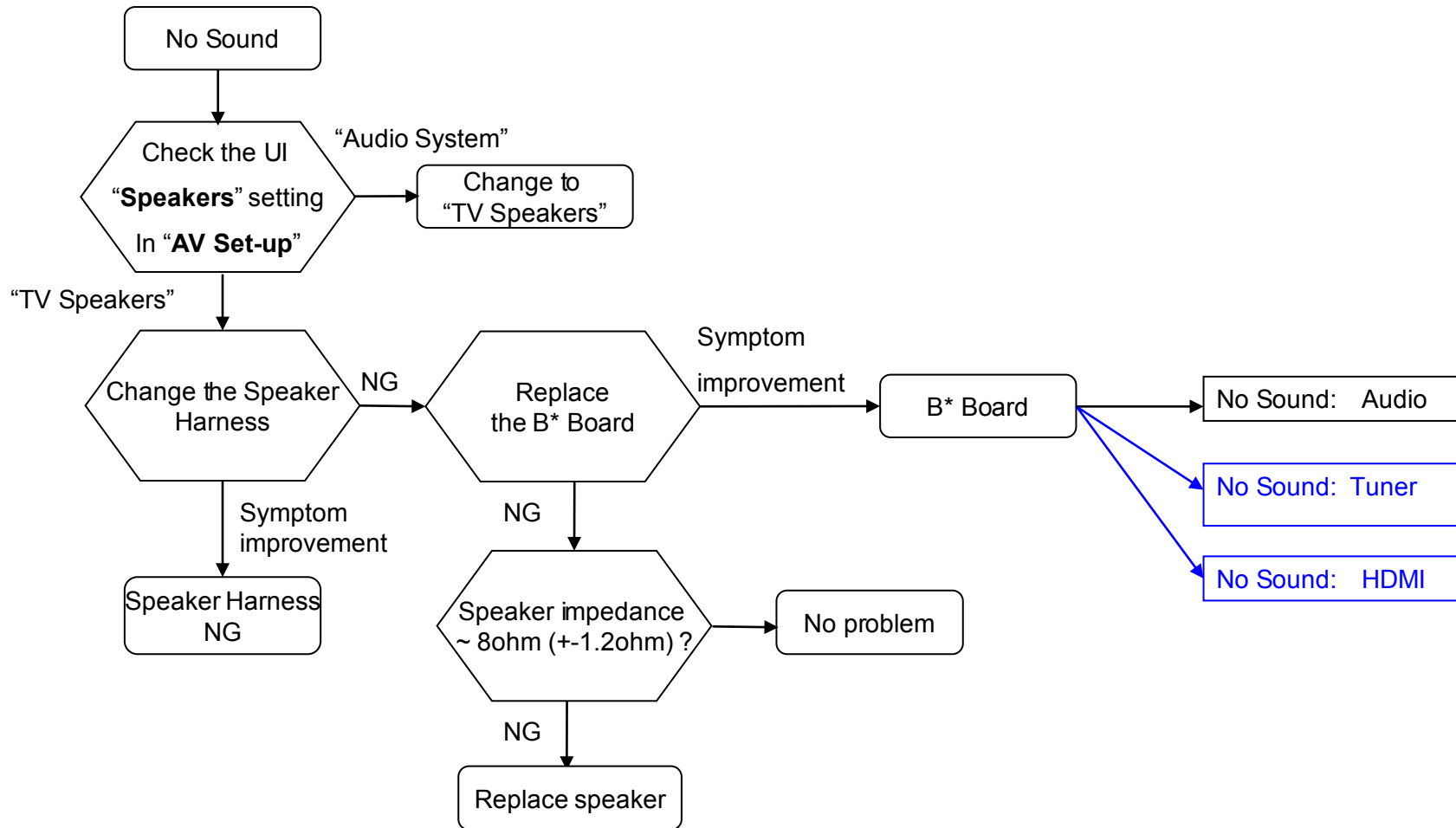

**3-3-1. Main Board Power Off Checking (for Main SP Lch & Rch) for BMX board only**

No	Checking Item	OK	NG
1	Check fuse F7751	Fuse short	Fuse open
2	Check connectivity audio Vcc to GND C7862 – GND C7864 – GND C7866 – GND	No short to GND	Either 1 short to GND
3	Check connectivity audio +3.3V_MAIN to GND (only for BMX board) IC7751 (Pin5) at R7879 – GND	No short to GND	Either 1 short to GND
4	Check connectivity audio output to GND. CN7751 Pin 1 – GND Pin 2 – GND Pin 3 – GND Pin 4 – GND	No short to GND	Either 1 of pin short to GND
5	Check connectivity audio output path (only for BMX board): L7751 (near to IC side) – CN7751 Pin4 L7752 (near to IC side) – CN7751 Pin3 L7753 (near to IC side) – CN7751 Pin2 L7754 (near to IC side) – CN7751 Pin1	Must have good connection (~0 Ω)	Open circuit.



**Troubleshooting Reference**  
**BMX board Side A**

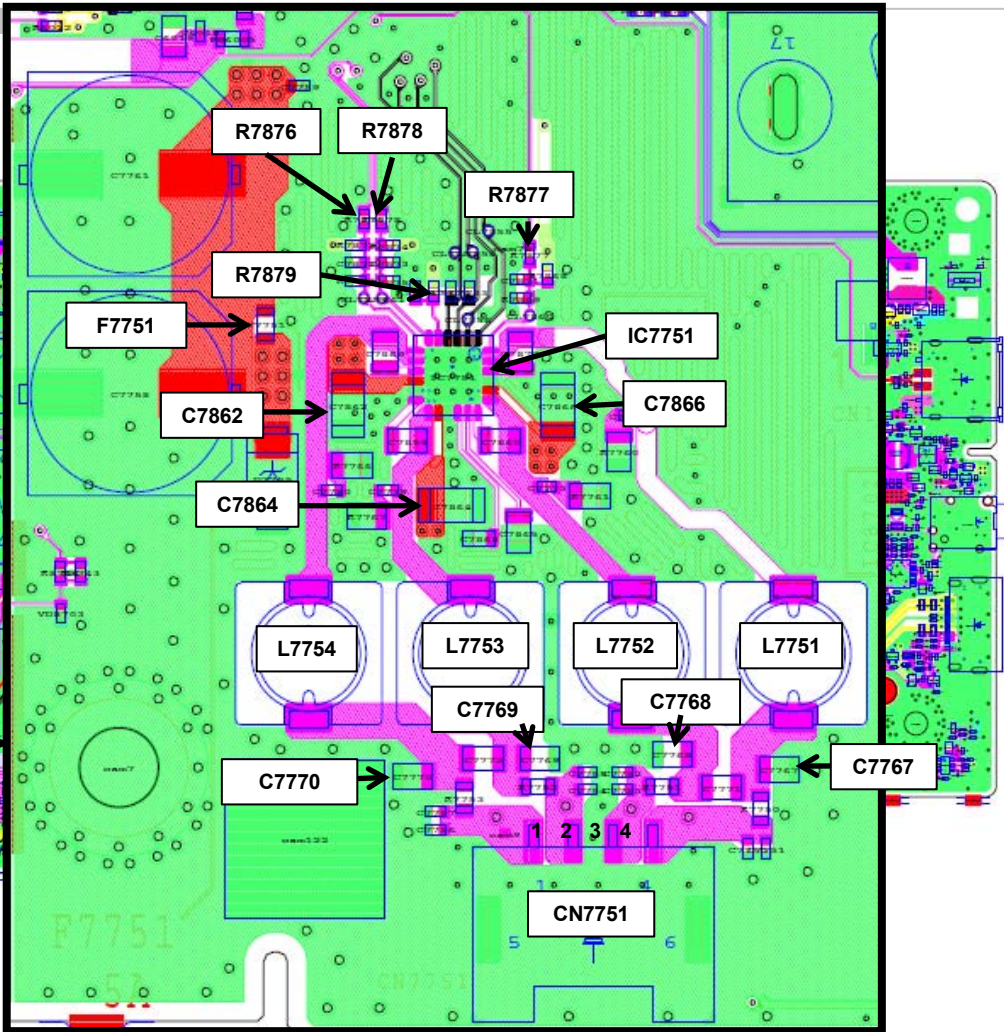
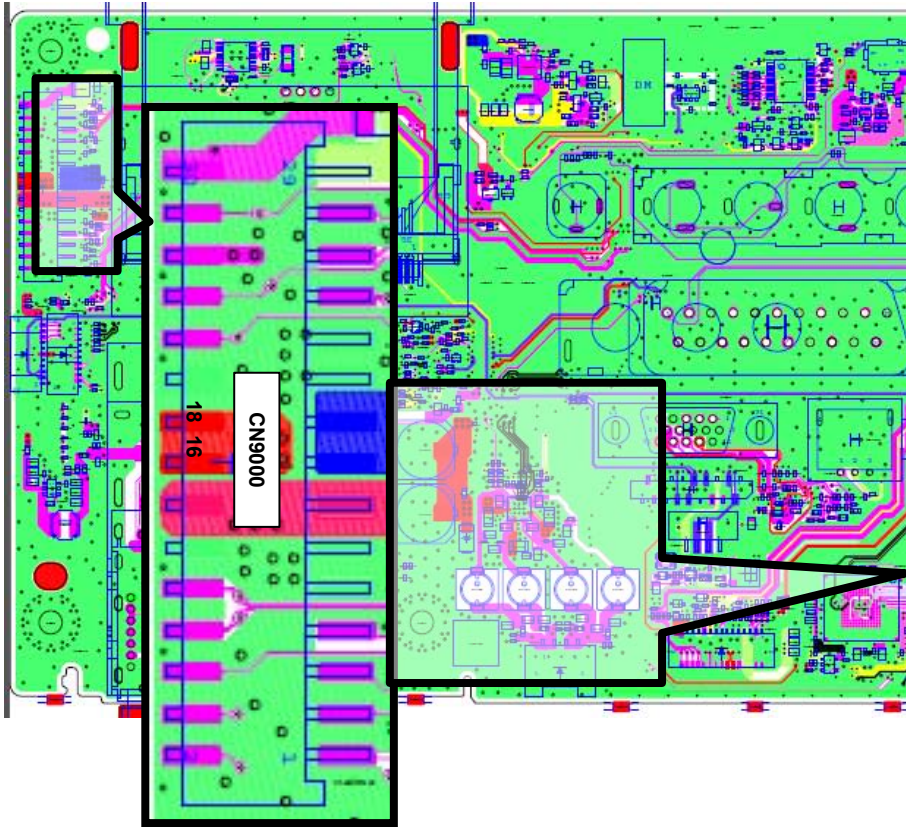

**Reference A**



Troubleshooting Reference  
BMX board Side A

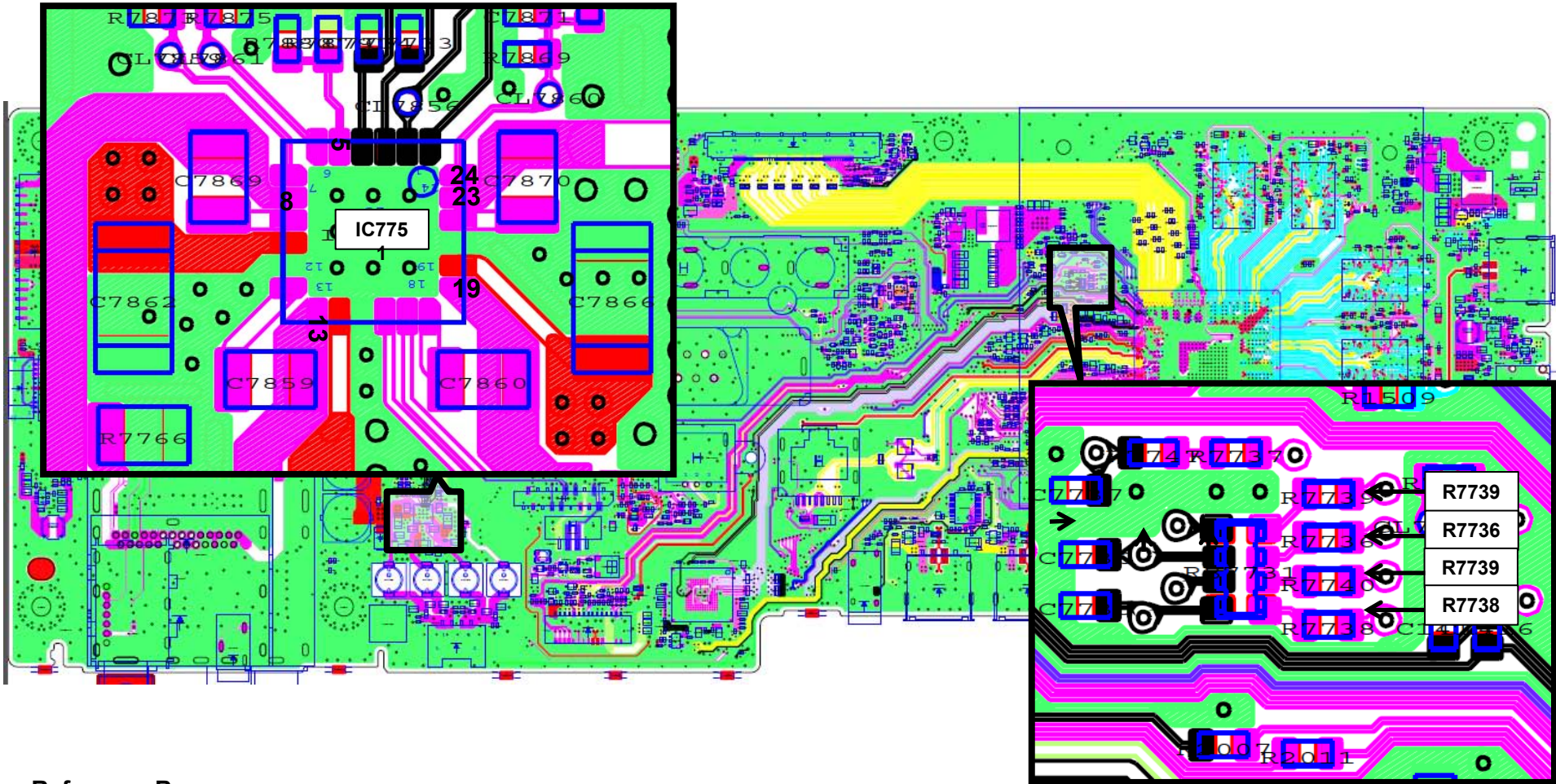

Reference B

**3-3-2. Main Board Power On Checking (for Main SP Lch & Rch) for BMX board only**

No	Checking Item	OK	NG	If ← NG	If ← NG
1	Check IC7751 side-terminal of L7751,L7752, L7753,L7754	Switching Freq = 384kHz or 768KHz ±20KHz Vrms = don't care	No switching frequency at either one of the CL	Go to next checking.	
2	Check F7751 MainSP (for BMX XM-H board only)	V(before fuse) = 12.5V ± 0.5V V(after fuse) = 12.5V ± 0.5 V	No voltage.	Check fuse broken? Check CN9000 Pin 16 &18 got 12.5V?	Change fuse (5A). Check power supply board audio VCC.
3	Check F7751 MainSP (for BMX XM-A, XM-AT and XM-DT only)	V(before fuse) = 19.5V ± 0.5V V(after fuse) = 19.5V ± 0.5V	No voltage.	Check fuse broken? Check CN9000 Pin 16 &18 got 19.5V?	Change fuse (5A). Check power supply board audio VCC.
4	Check IC7751 (Pin 5) at R7879 (for BMX board only)	V(before R7879) = 3.3V ± 0.5V V(after R7879) = 3.3V ± 0.5V	No voltage.		Check +3.3V_MAIN supply.
5	Check R7876, R7877, R7878	Vdc = 3.3V ± 0.3V	Vdc < 0.8V	R7877 NG, Check IC7751	R7876, R7878 NG, Check IC1000
6	Check R7736, R7738, R7739, and R7740	R7738 = 12.288MHz R7740 = 3.072MHz R7739 = 48KHz R7736 = moving CLK All Vp-p ≈ 3.3V	If no frequency at R7738, R7739, and R7740, Muffin IC (IC1000) NG. If no frequency at R7736 make sure sound source OK.	If sound source OK, but at R7736 = NG, Muffin IC (IC1000) NG.	

**Note : Parts location refer BMX Board : Reference A and Reference B.**

**3-3-3. No Sound: HP / Lineout Only for BMX board only**

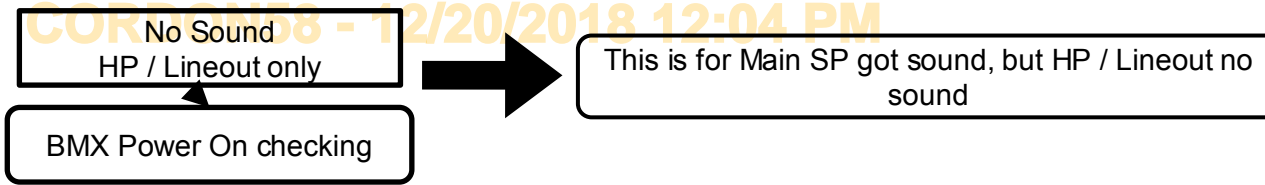

**GN1 Main Board Power On Checking**

No	Checking Item	OK	NG	If ← NG
1	Insert HP Jack. Check R7705	Vdc = 3.3V ± 0.3V	Vdc = 0V or < 1V	Check HP_DET line (R7705 – for BMX) got short to GND? If short to GND replace board.
2	Check IC7701 Pin 5 (X_AUDIO_MUTE_SPHP)	Vdc = 3.3V ± 0.3V	Vdc = 0V or < 1V	Check X_AUDIO_MUTE_SPHP (Pin 5) short to GND. If short to GND replace board.
3	Check JL7701 and JL7702. (with audio signal input)	Can see audio signal waveform	Cannot see audio signal waveform	Go to below item No. 4 for checking
4	Check IC7701 pin 9	Vdc = 3.3V ± 0.3V	No 3.3V supply.	
5	Check R7707, R7708 (with audio signal input)	Can see audio signal waveform	Cannot see audio signal waveform	Muffin IC (IC1000) NG



3-3-3. No Sound: HP / Lineout Only for BMX board only

Troubleshooting Reference  
BMX board Side A

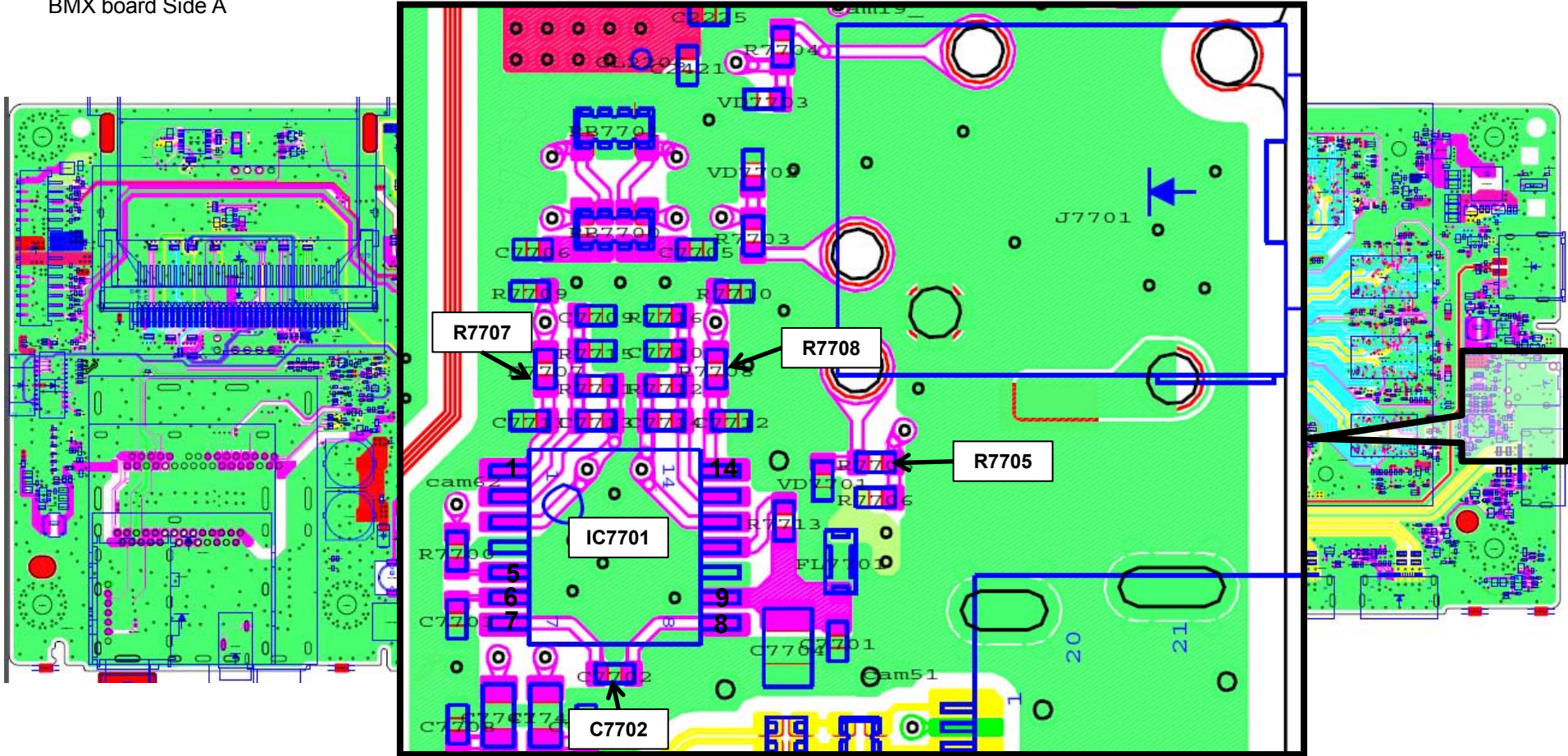



**3-3-3. No Sound: HP / Lineout Only for BMX board only**

Troubleshooting Reference  
BMX board Side B

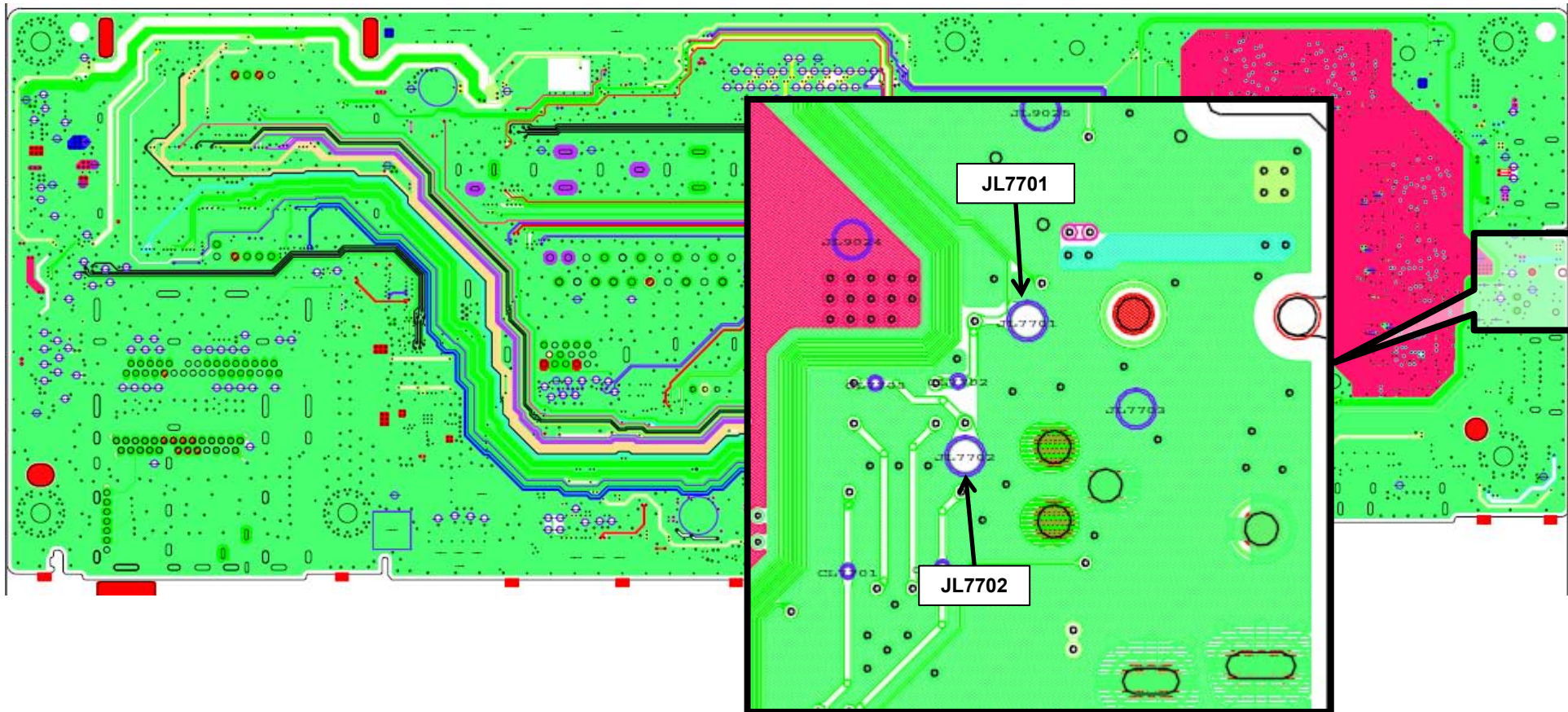

**3-3-4. No Sound : Scart Out Audio (For Europe model) BMX board only**

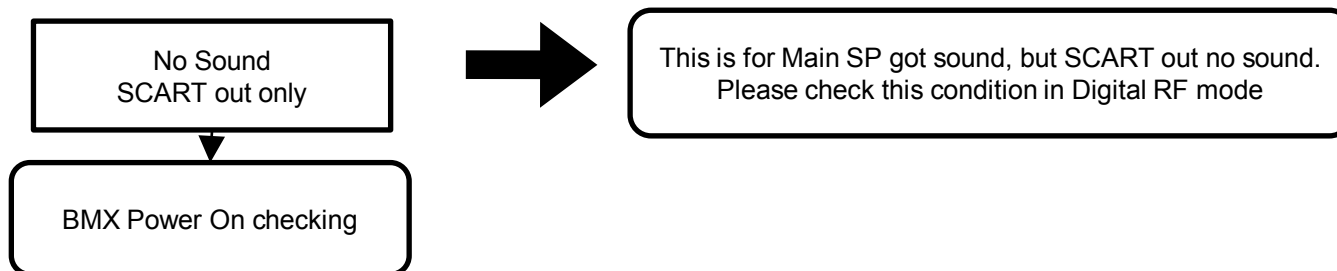

**GN1 Main Board Power On Checking**

No	Checking Item	OK	NG	If ← NG
1	Check CL7851 ,CL7852. (with audio signal input – Digital RF mode)	Can see output audio signal waveform	Cannot see audio signal waveform	Go to checking 3-3-2: NO SOUND: Audio (Additional : For Europe models only)
2	Check IC7851 pin3	Vdc = 3.3V ± 0.3V	No 3.3V supply	
3	Check C7854, C7855 (with audio signal input – Digital RF mode)	Can see input audio signal waveform	Cannot see audio signal waveform	Muffin IC (IC1000) NG



Troubleshooting Reference  
BMX board Side A

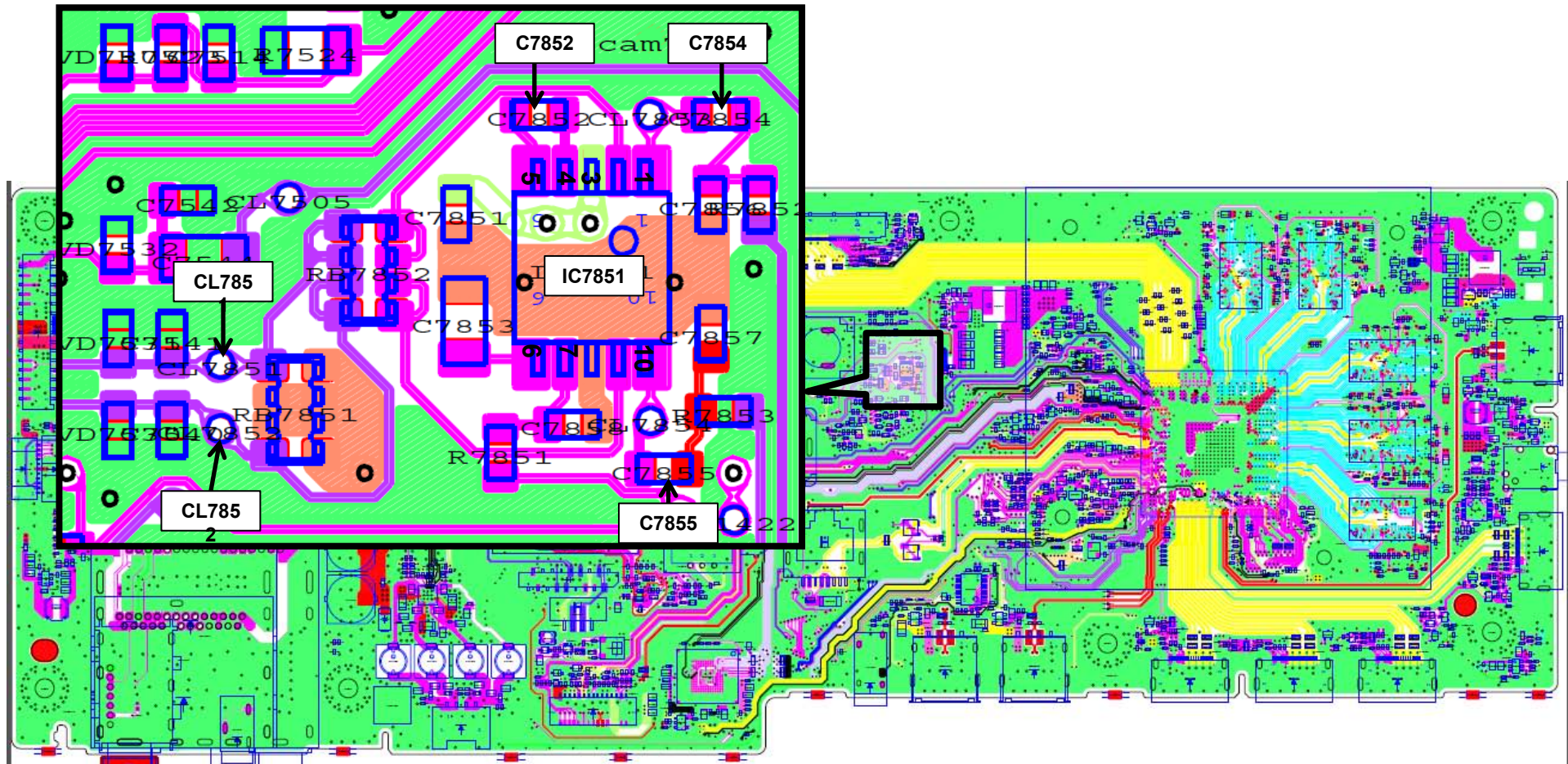

**3-3-5. NO SOUND: TUNER**

**3-3-6. NO SOUND: MHL**

This troubleshooting is only for Analog

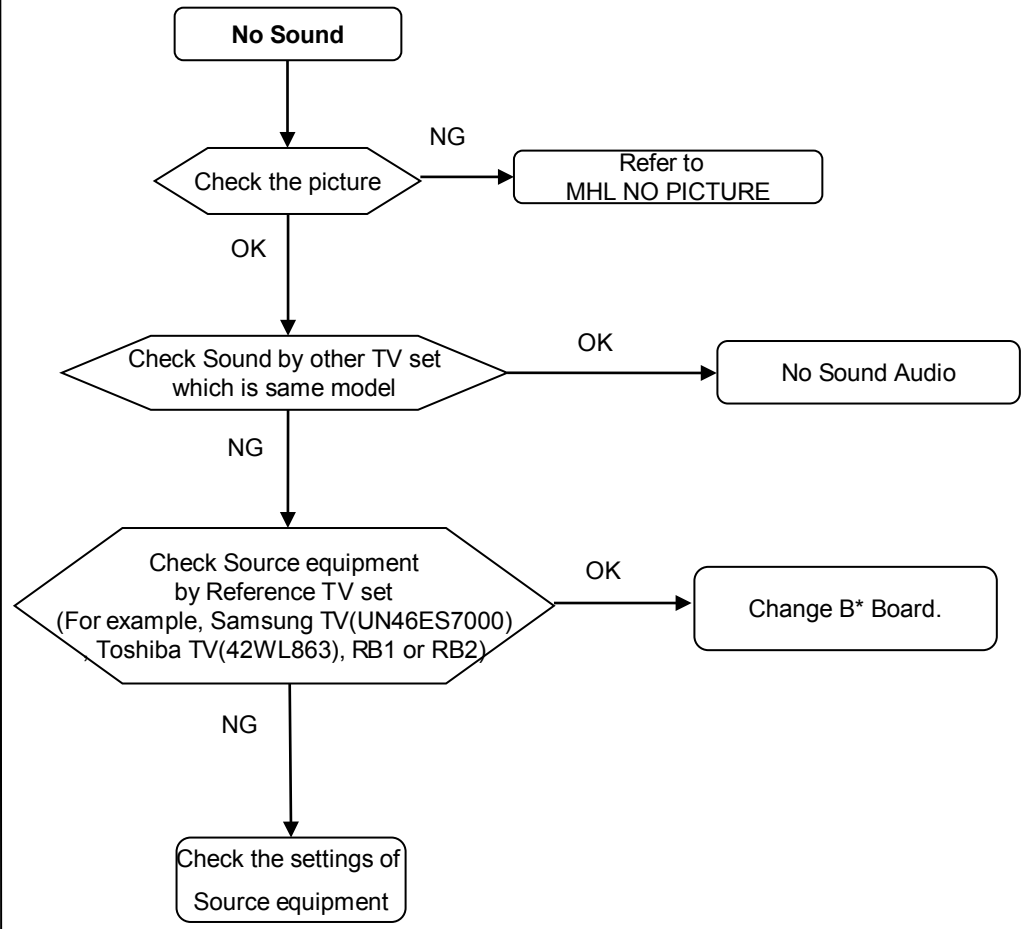
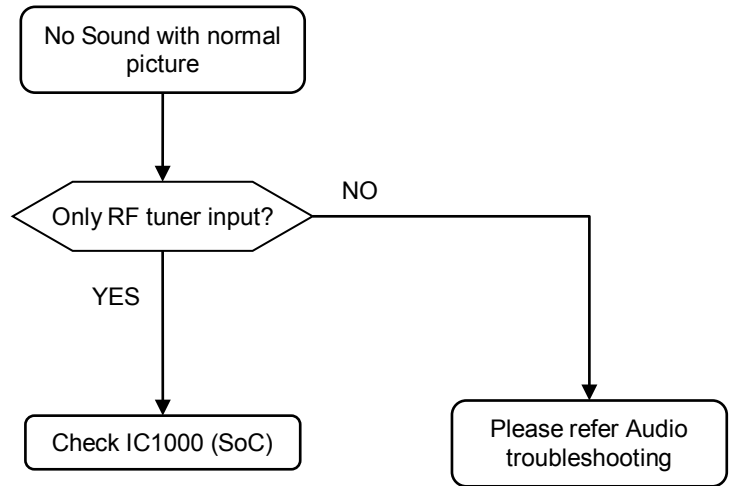



### 3-3-7. NO SOUND: HDMI1/2/3/4

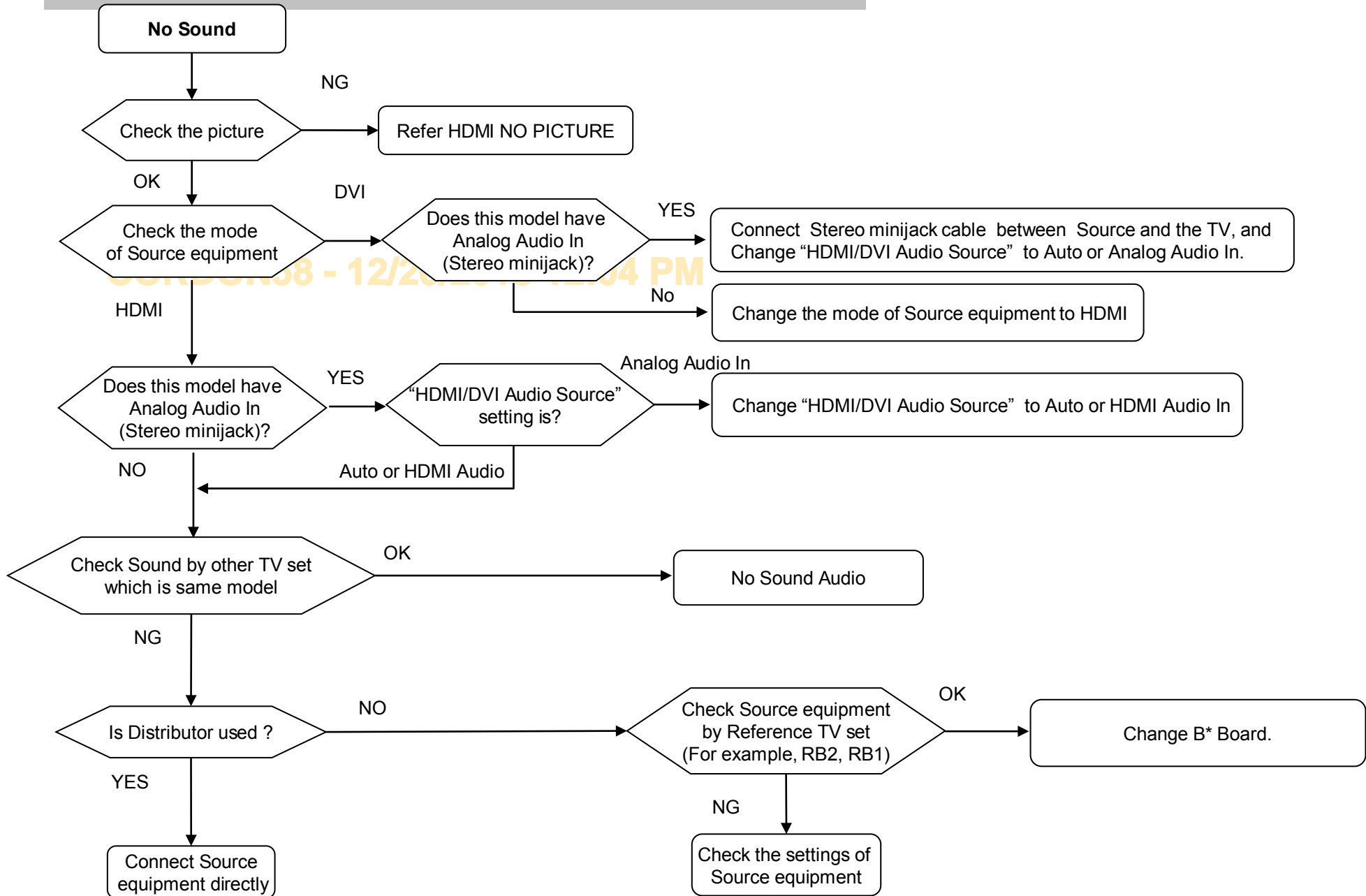

### 3-4. NO PICTURE

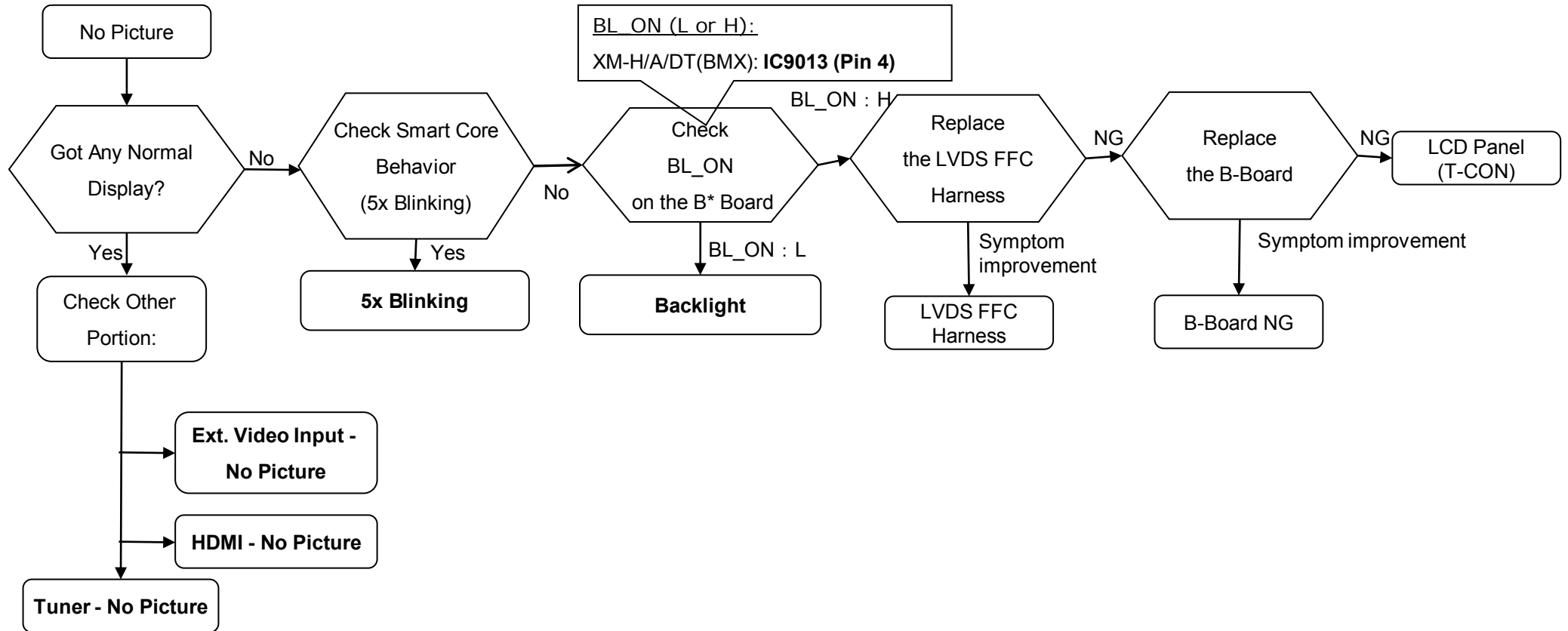

**Note: Board Details refer Section 3 main page.**

CORDON58 - 12/20/2018 12:04 PM

## BMX Probing Points

BMX (B-Side)

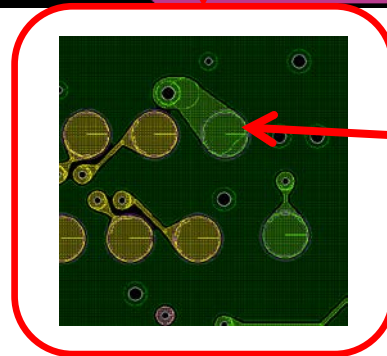
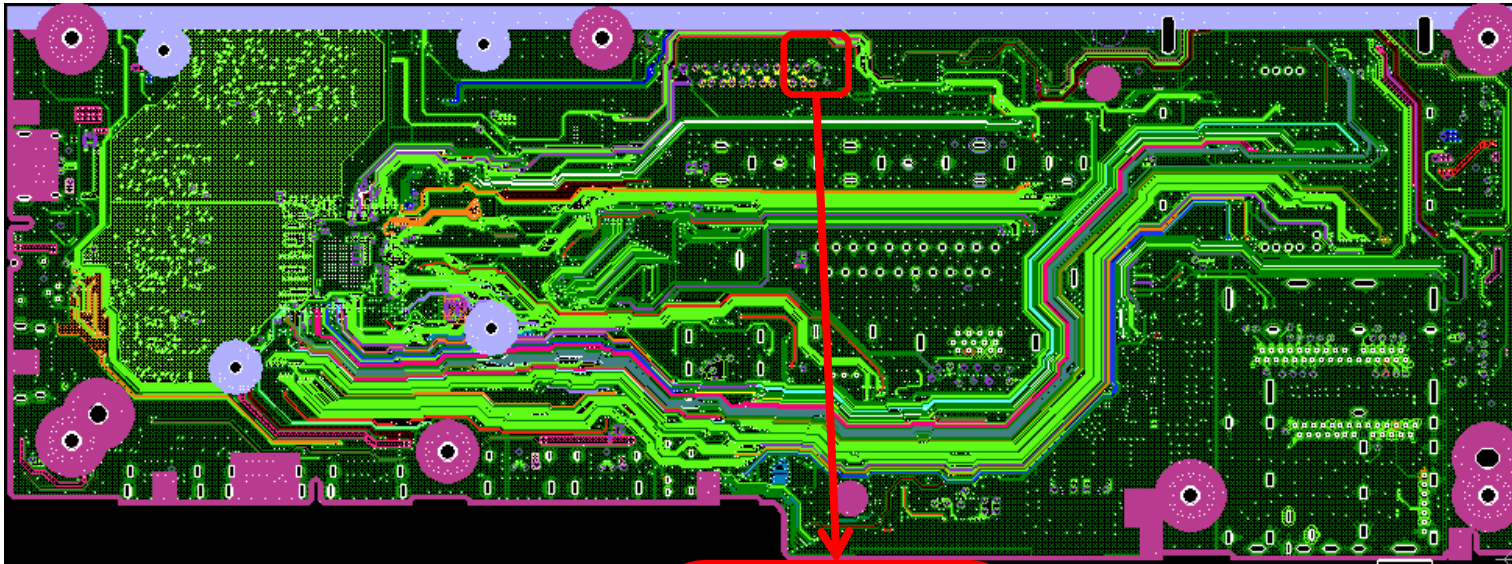

JL8401  
(PANEL\_VCC)

## BMX Probing Points

**BMX (A-Side)**

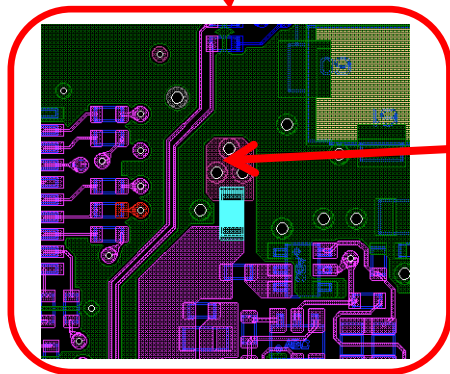
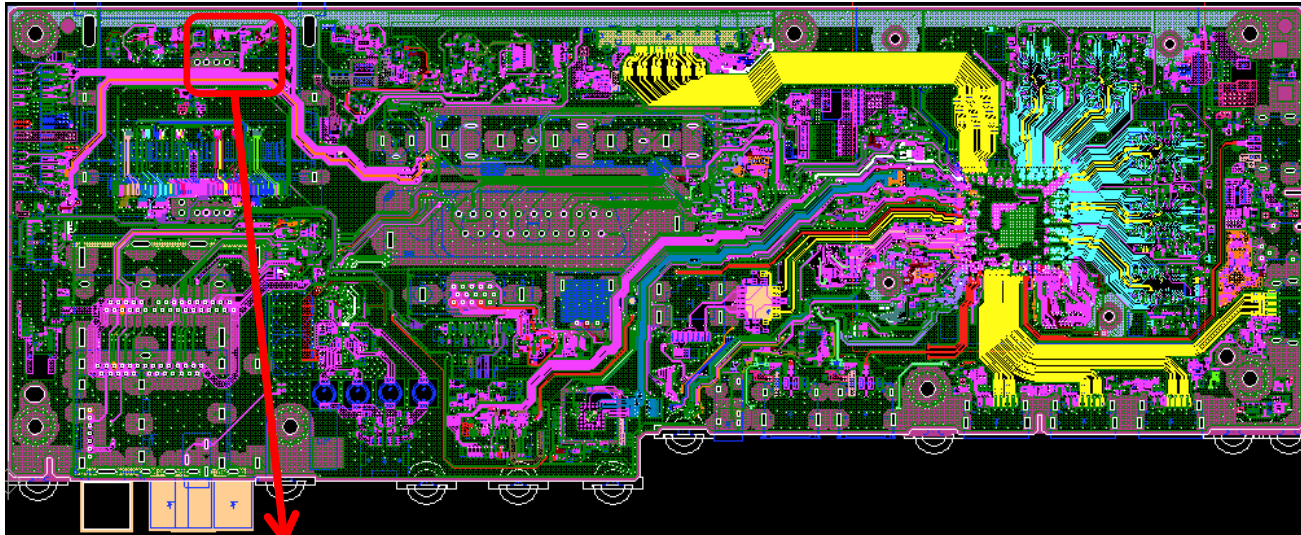

**F8401**  
(+12V\_REG)



## BMX Probing Points

BMX (A-Side)

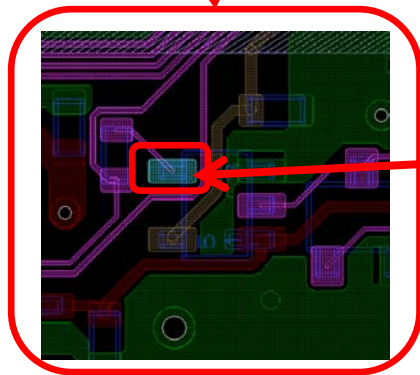
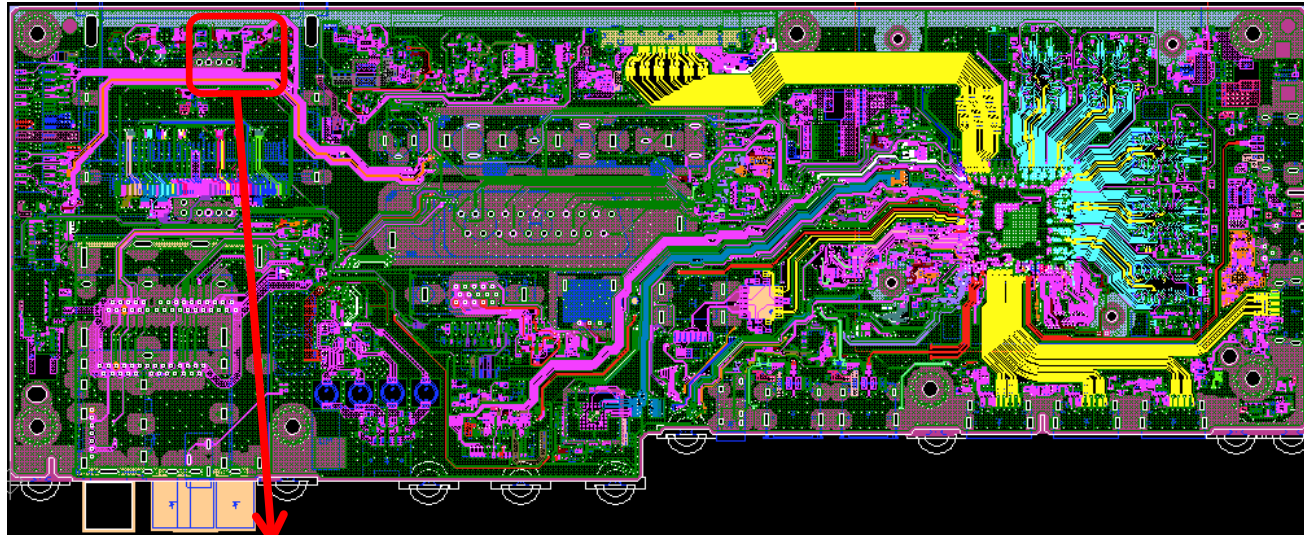

IC9013 (Pin 4)  
(BL\_ON)

### 3-4-1. Video Analog Signal Path

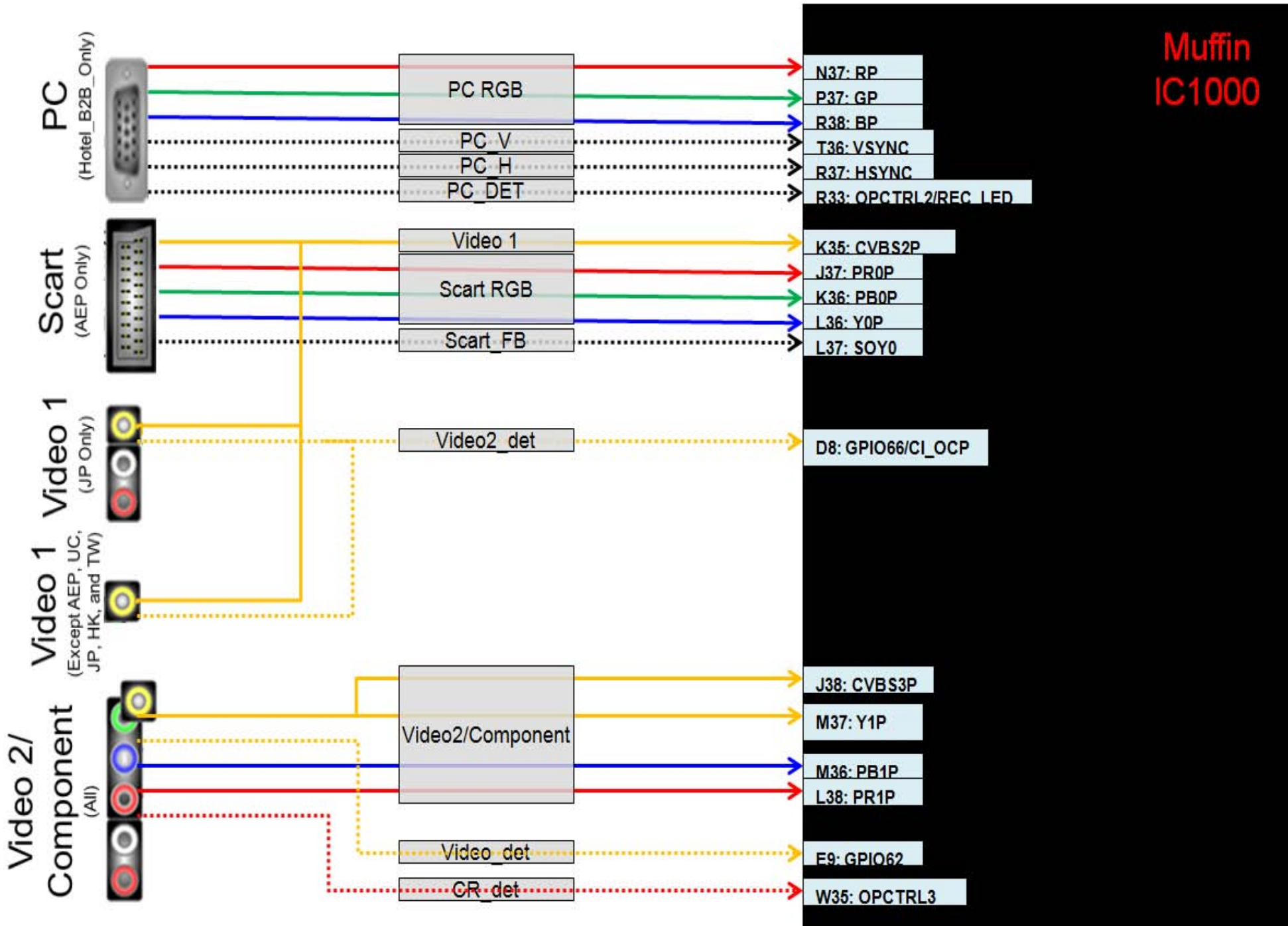



### 3-4-2. FOR ANALOG TUNING: @ All destination except JP.

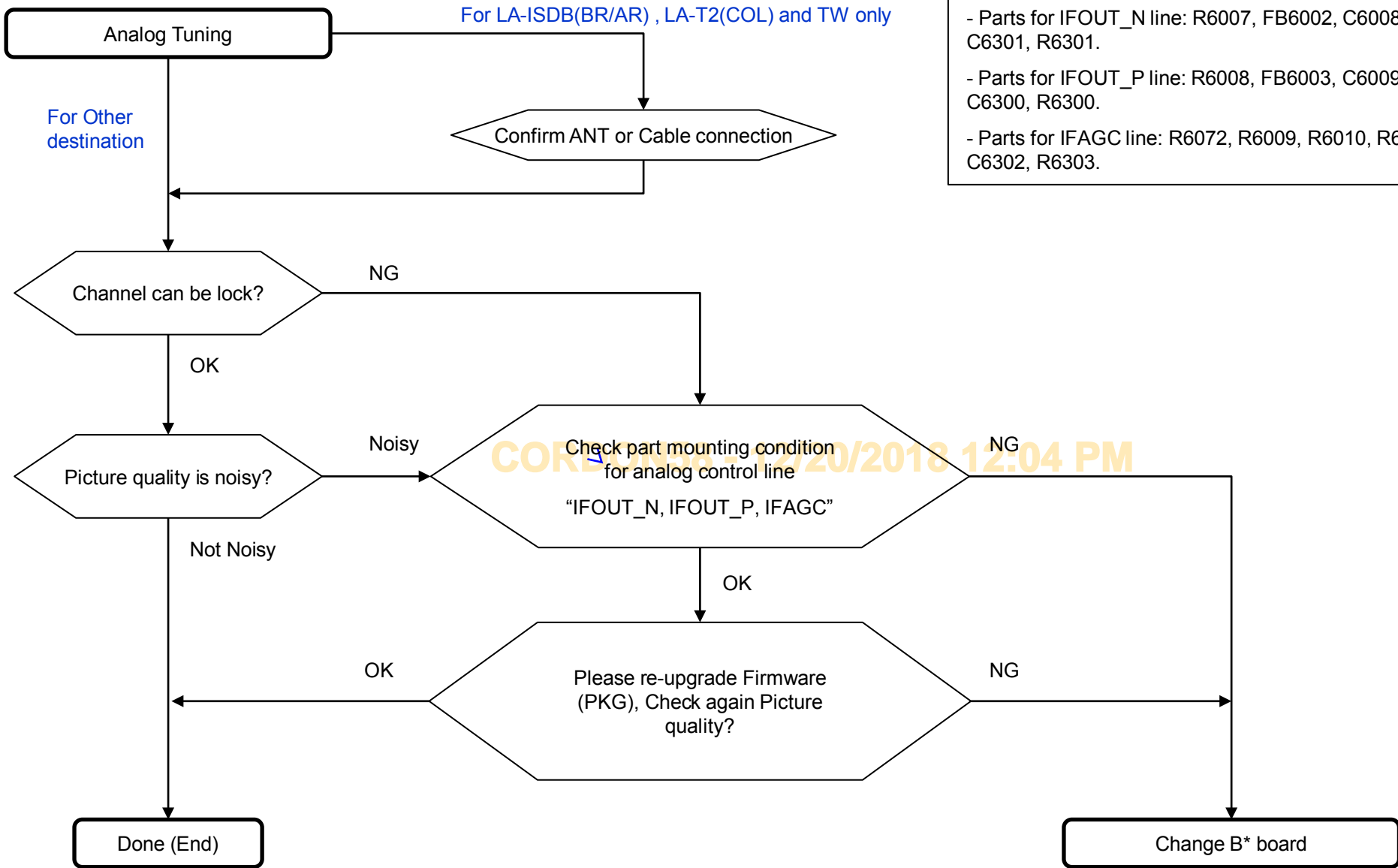

Notes:

- Parts for IFOUT\_N line: R6007, FB6002, C6008, R6327, C6301, R6301.
- Parts for IFOUT\_P line: R6008, FB6003, C6009, R6326, C6300, R6300.
- Parts for IFAGC line: R6072, R6009, R6010, R6069, C6302, R6303.

**Note: Board Details refer Section 3 main page.**

BMX BOARD (A Side)

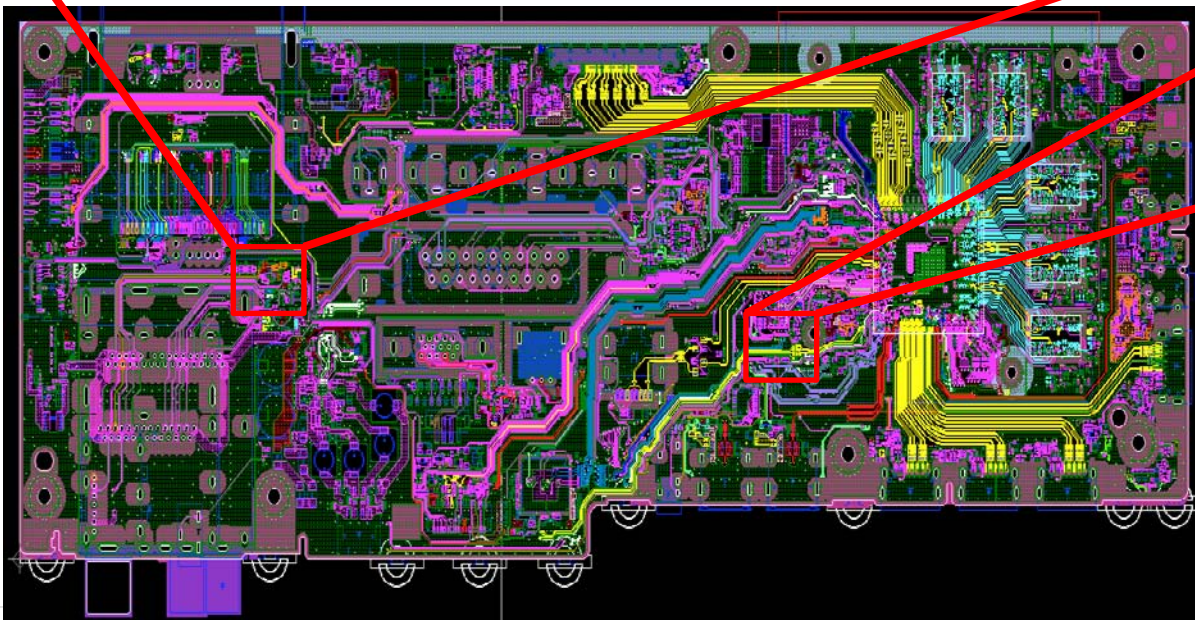
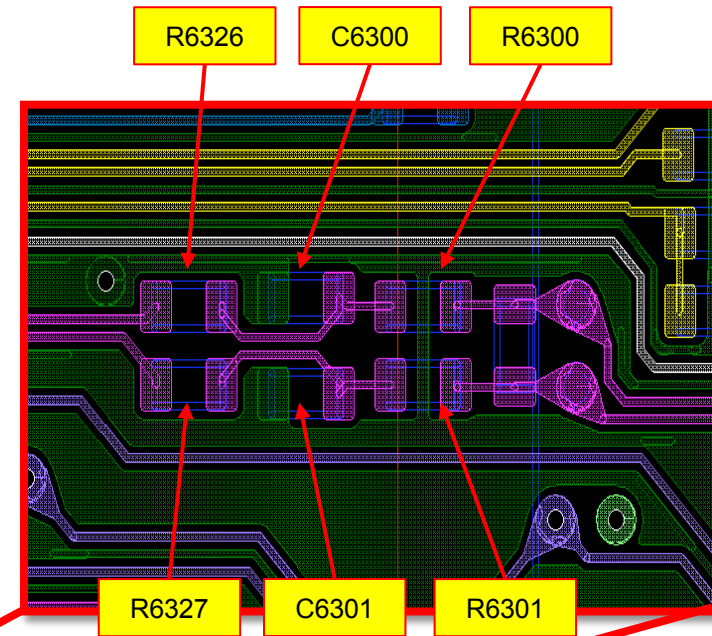
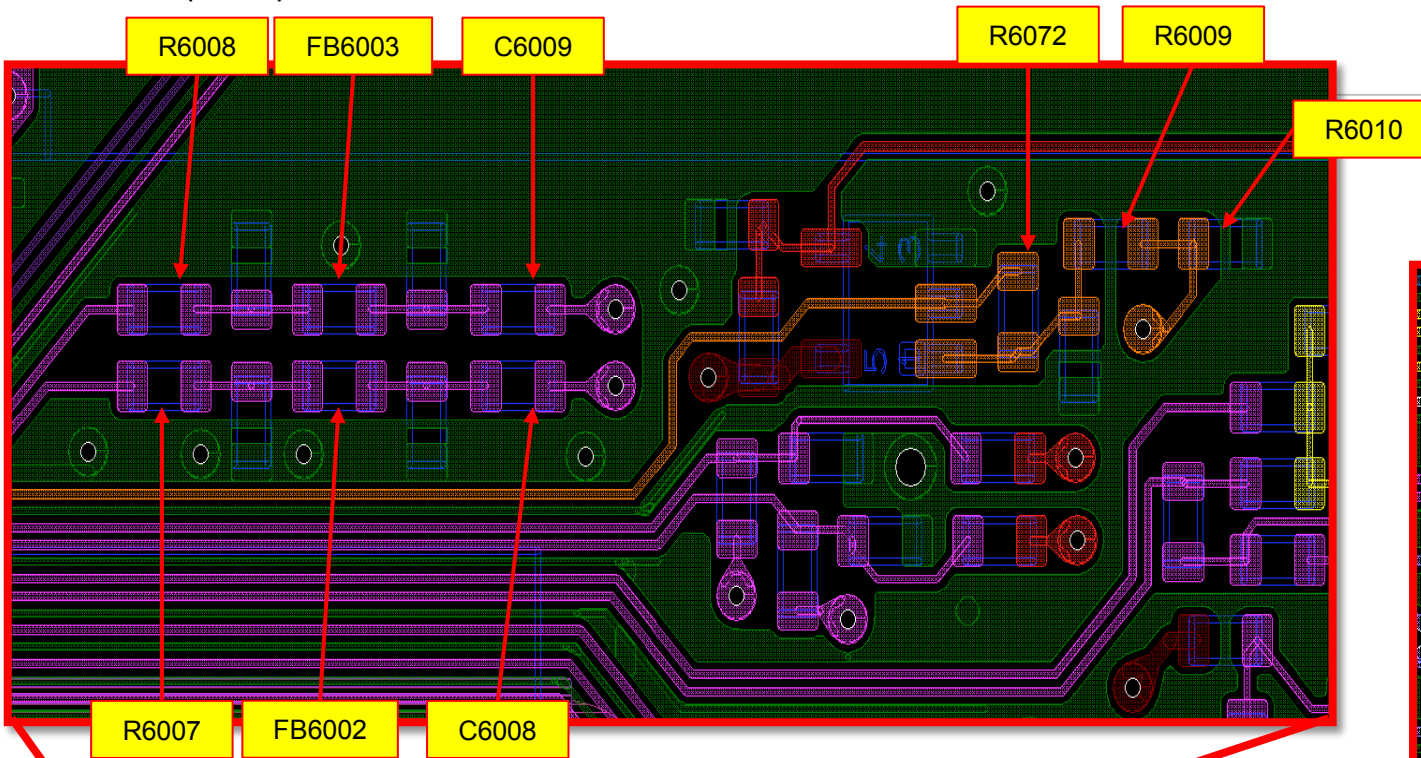



BMX BOARD (A Side)

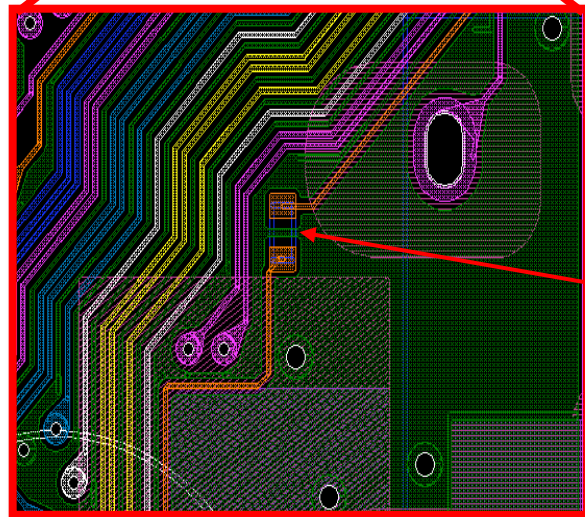
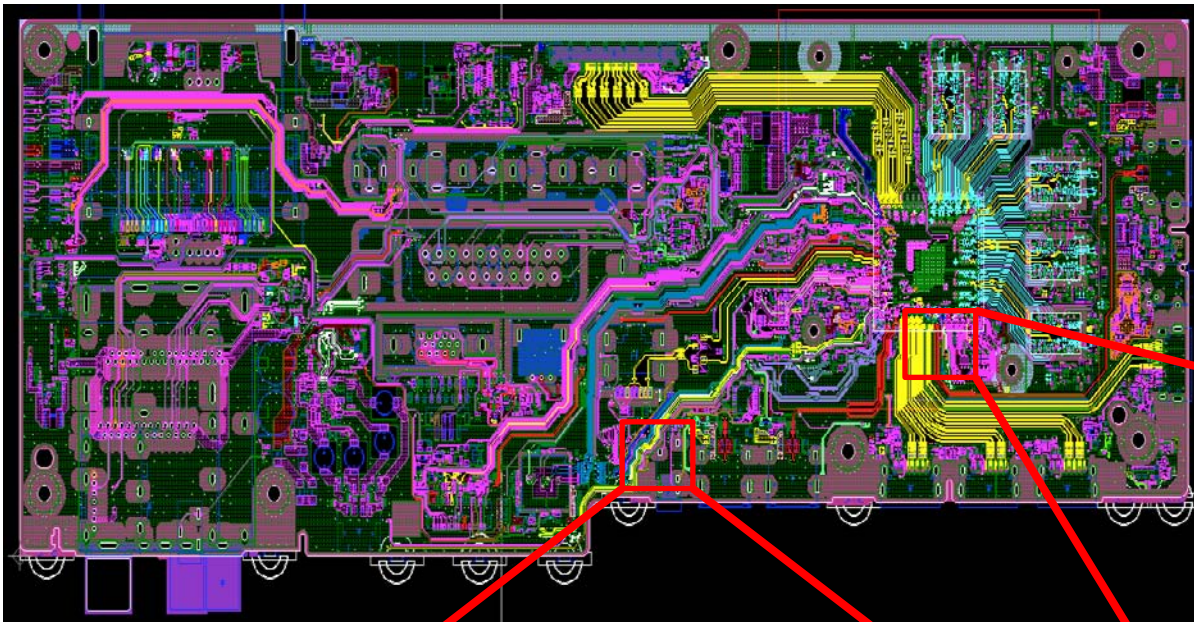

R6069

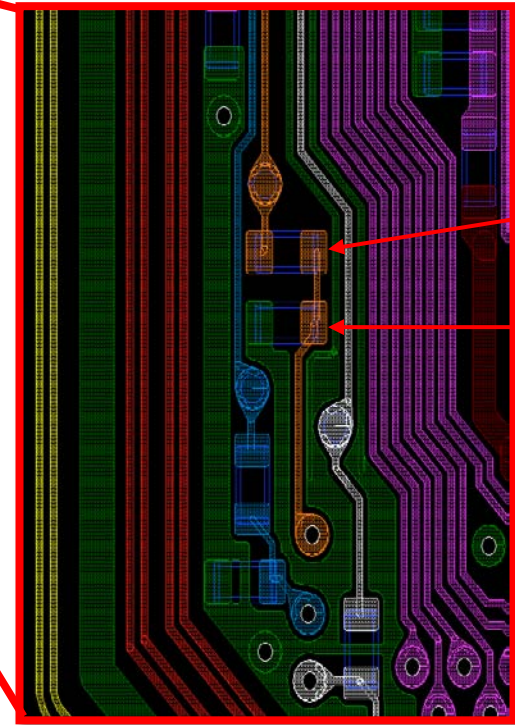

R6303

C6302

### 3-4-3.FOR DIGITAL TUNING 1: @ TW and LA-ATSC(MX/UC).

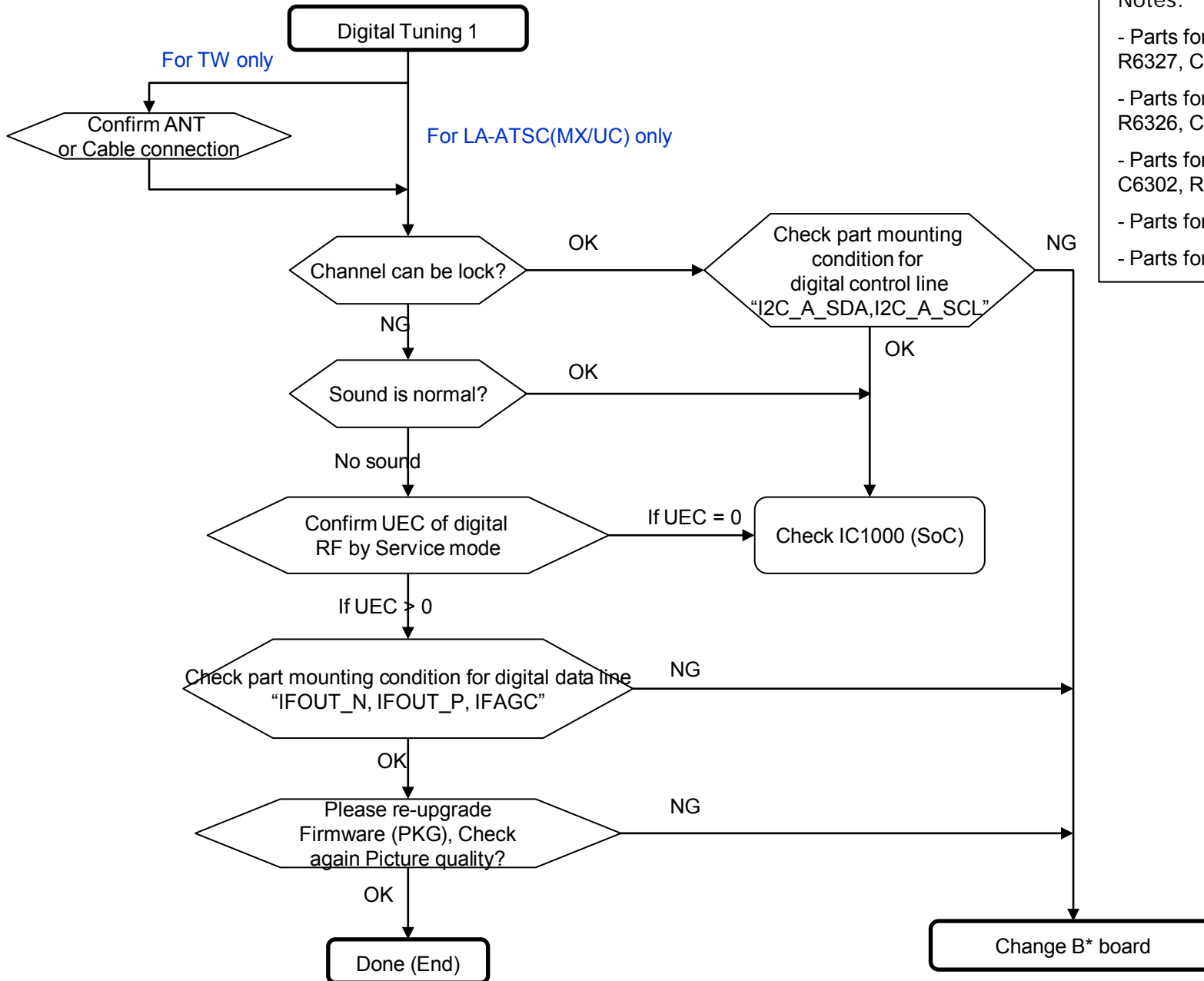

Notes:

- Parts for IFOUT\_N line: R6007, FB6002, C6008, R6327, C6301, R6301.
- Parts for IFOUT\_P line: R6008, FB6003, C6009, R6326, C6300, R6300.
- Parts for IFAGC line: R6072, R6009, R6010, R6069, C6302, R6303.
- Parts for I2C\_A\_SDA line: R6001, C6004.
- Parts for I2C\_A\_SCL line: R6002, C6005.



**BMX BOARD (A Side)**

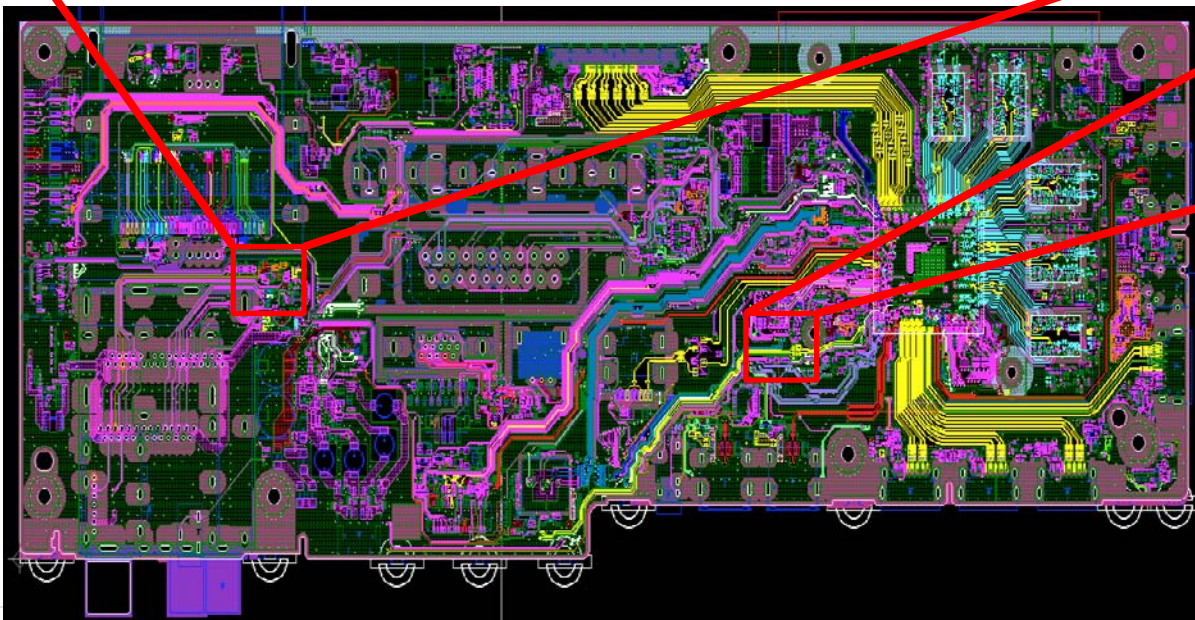
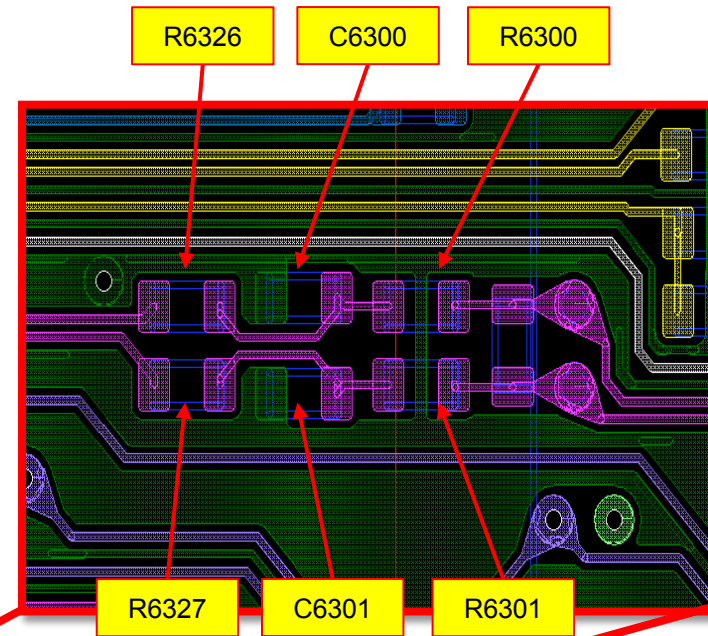
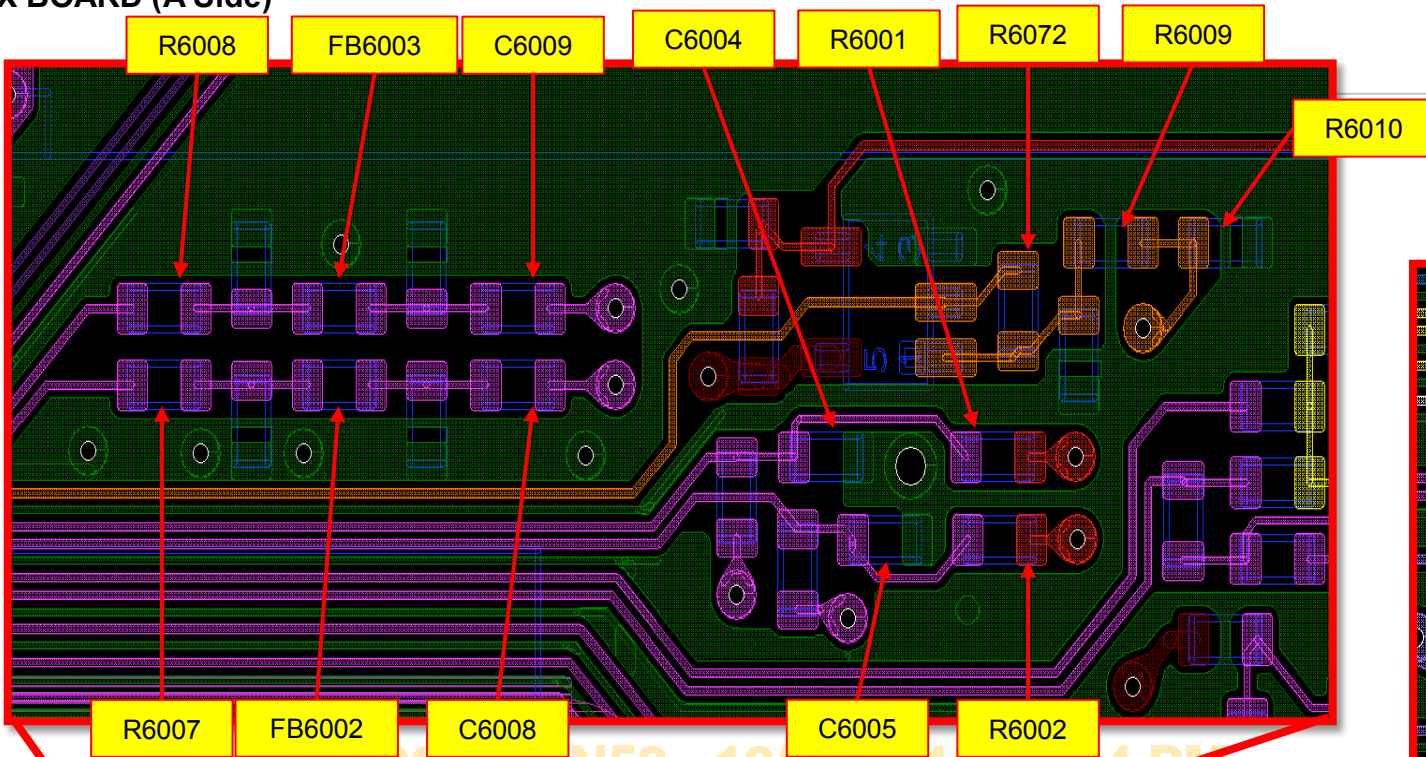

CORDON58 - 12/20/2018 12:04 PM



## BMX BOARD (A Side)

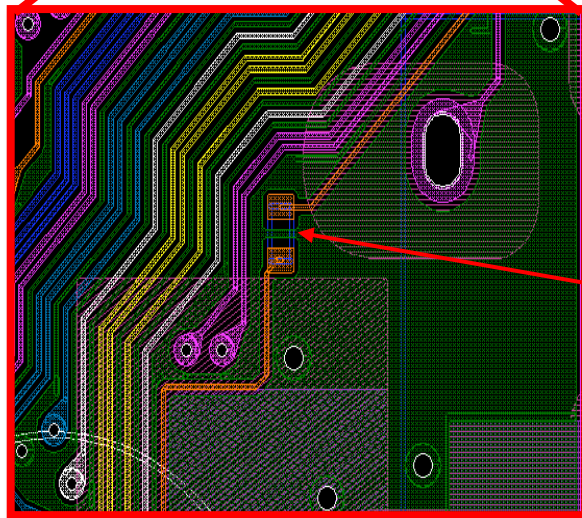
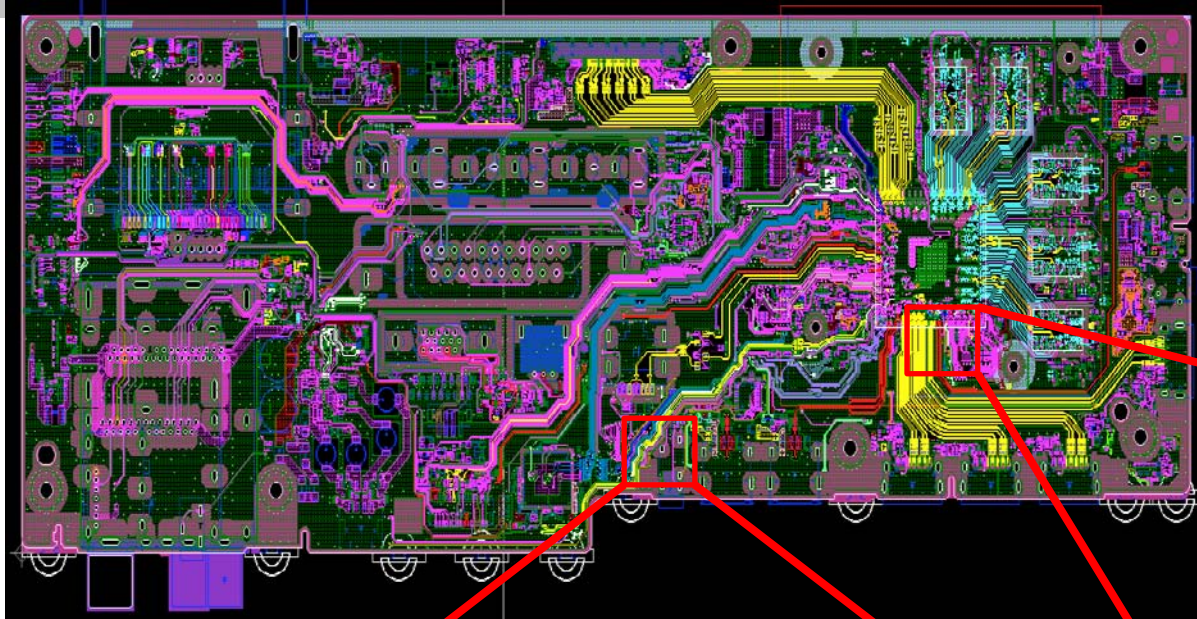

R6069

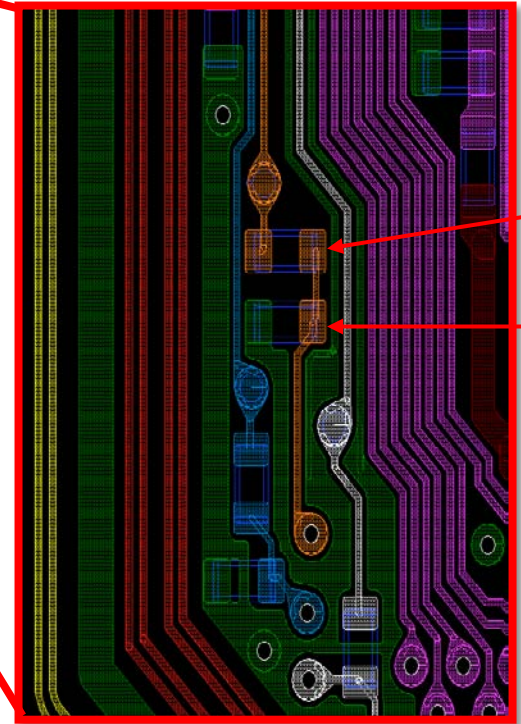

R6303

C6302



3-4-4.FOR DIGITAL TUNING 2: @ AEP-T2S2, JP, PA\_T2, CH/HK, LA-ISDB(BR/AR) and LA-T2(COL).

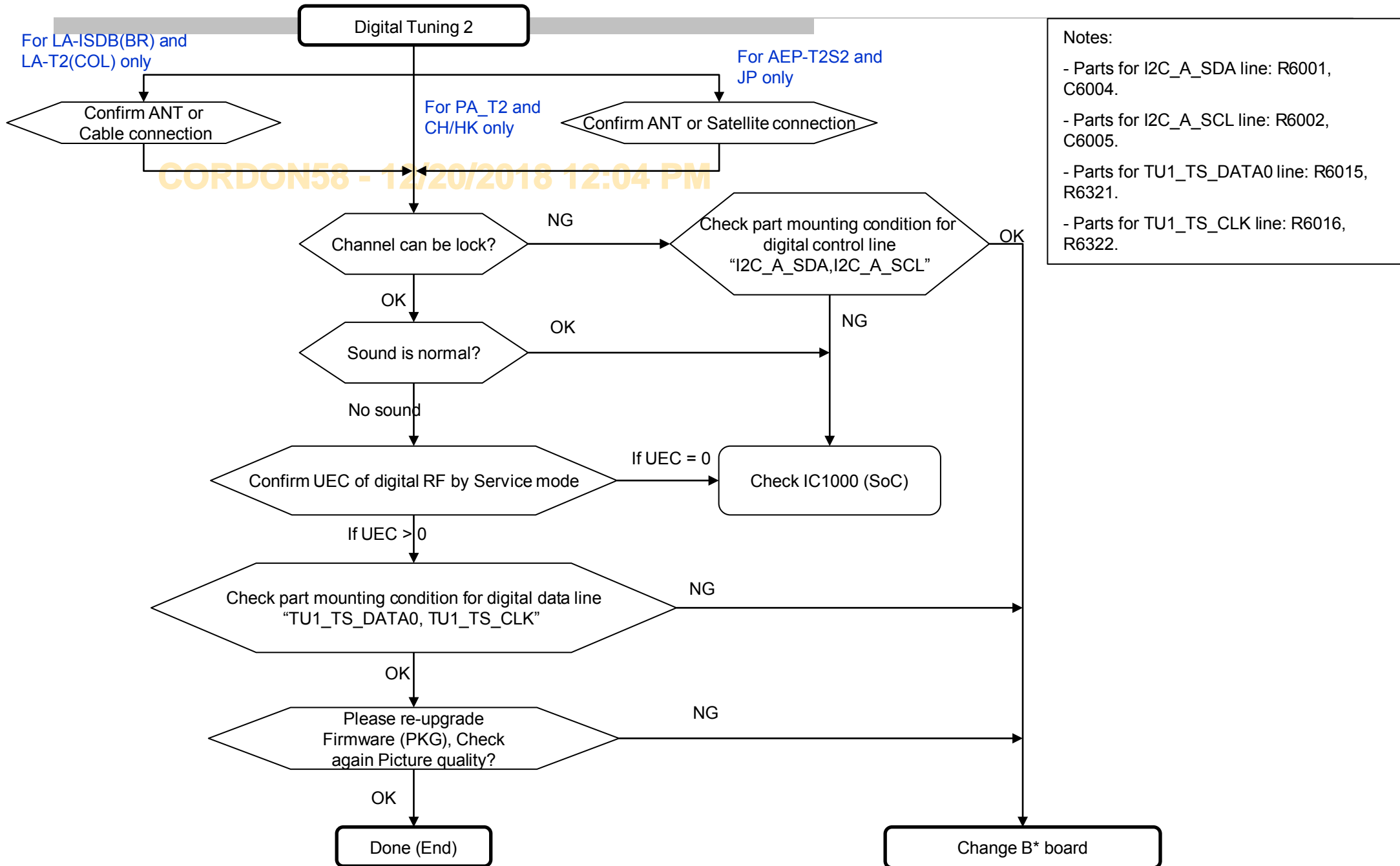

Notes:

- Parts for I2C\_A\_SDA line: R6001, C6004.
- Parts for I2C\_A\_SCL line: R6002, C6005.
- Parts for TU1\_TS\_DATA0 line: R6015, R6321.
- Parts for TU1\_TS\_CLK line: R6016, R6322.

CORDON58 - 12/20/2018 12:04 PM

BMX BOARD (A Side)

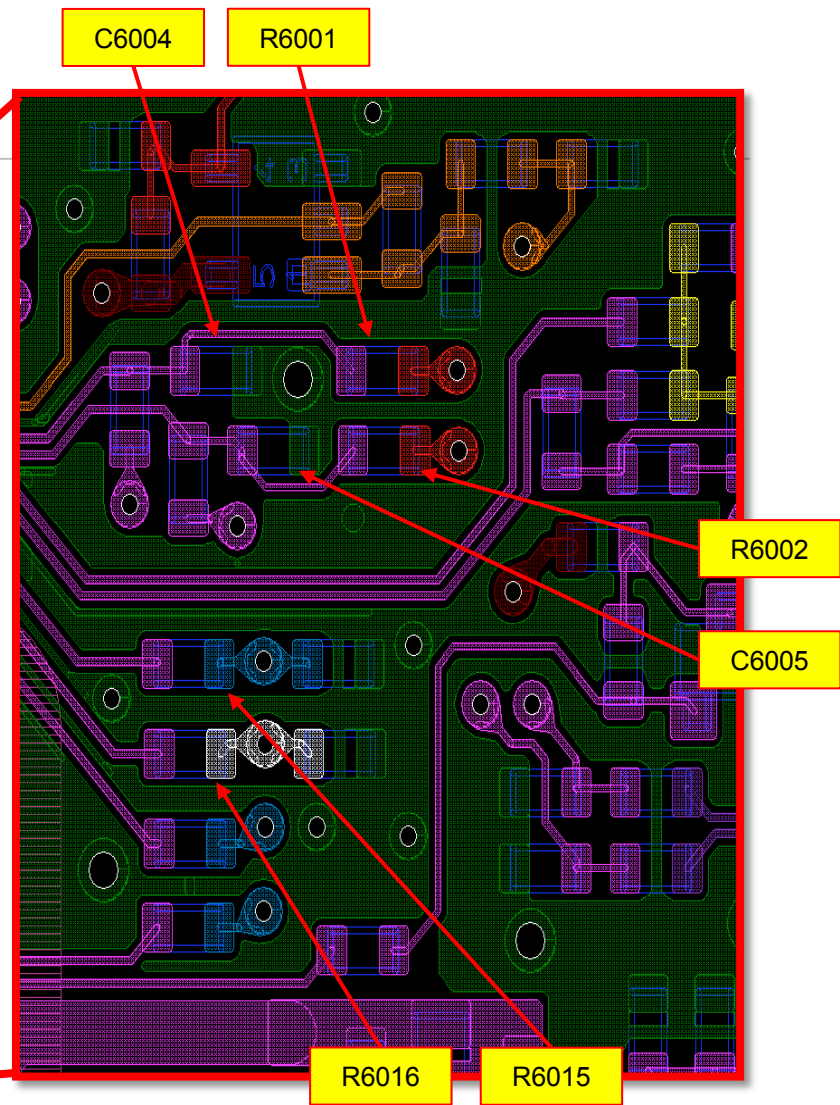
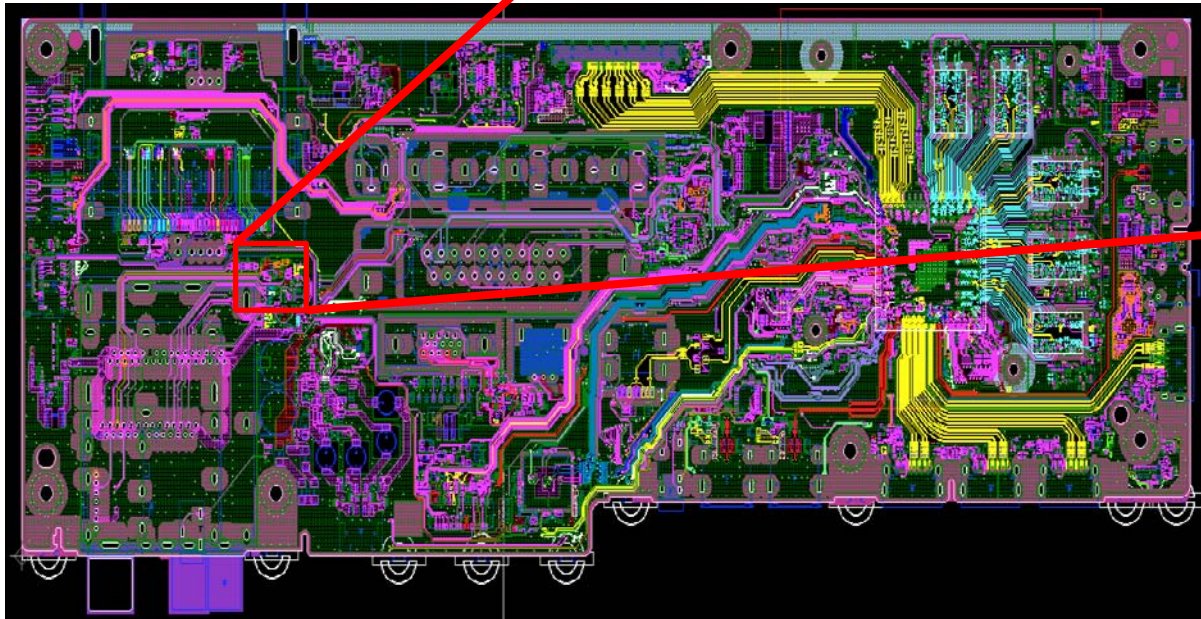



# BMX BOARD (A Side)

10/20/2018 12:04 PM

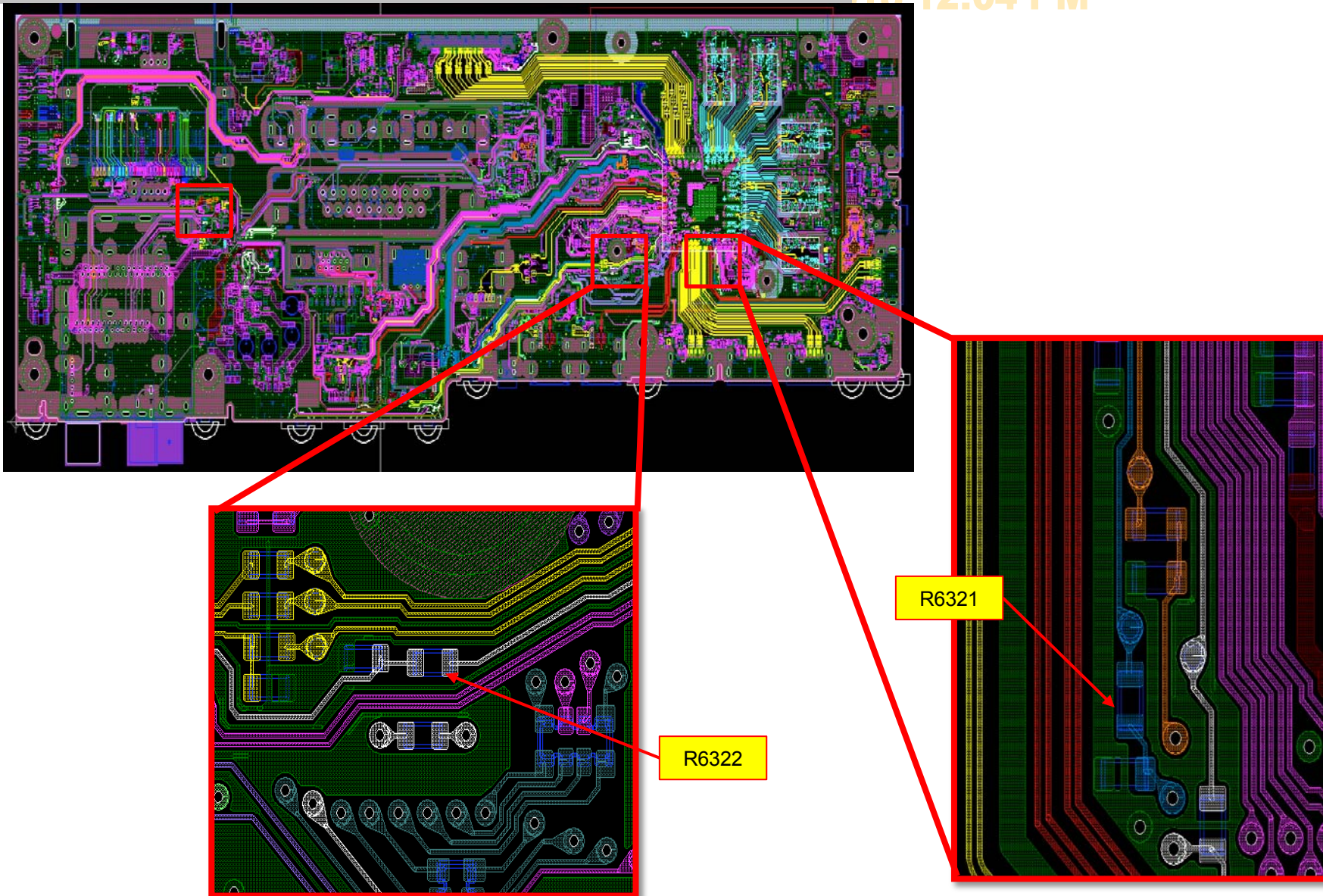

### 3-4-5. NO PICTURE: HDMI1

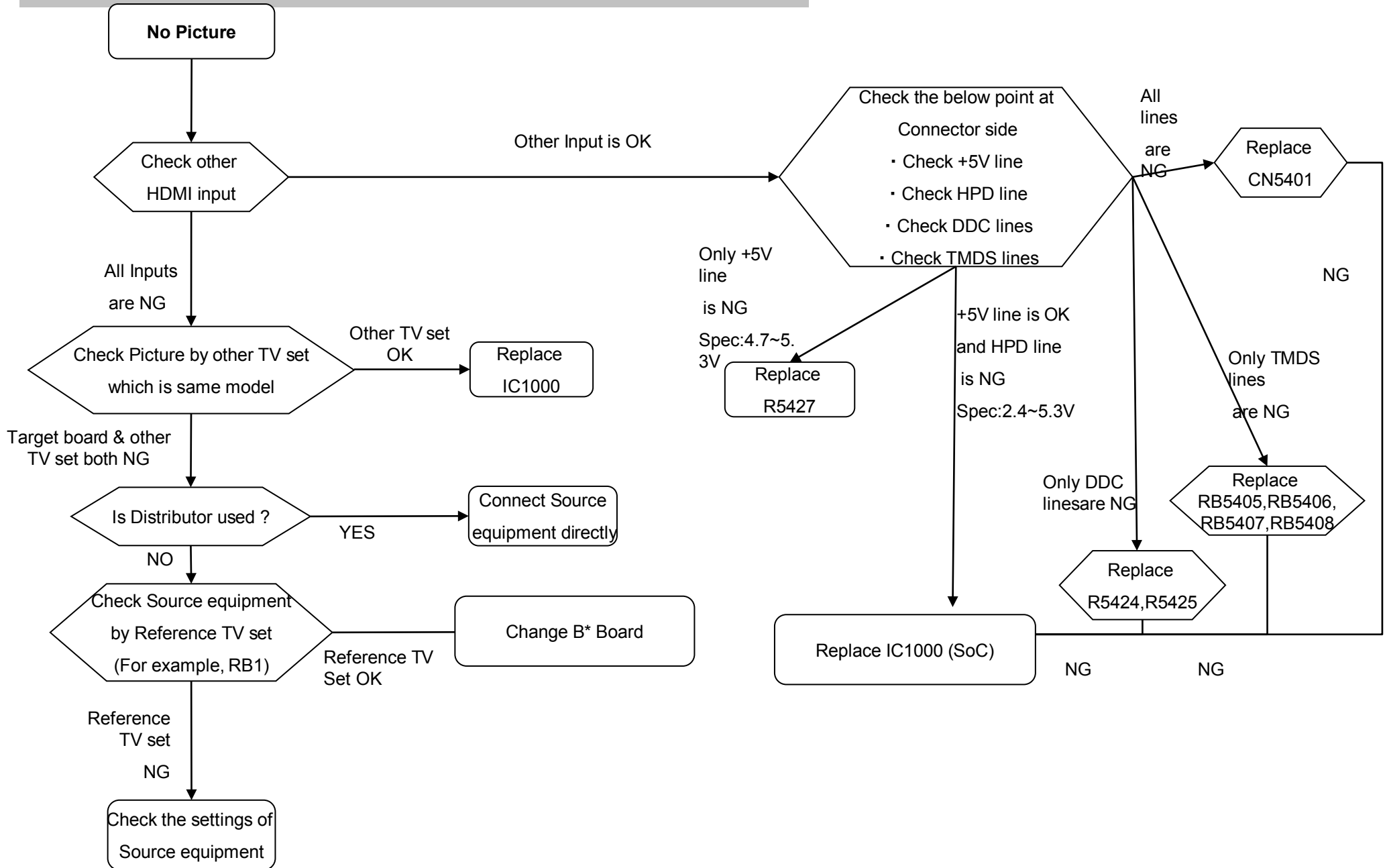



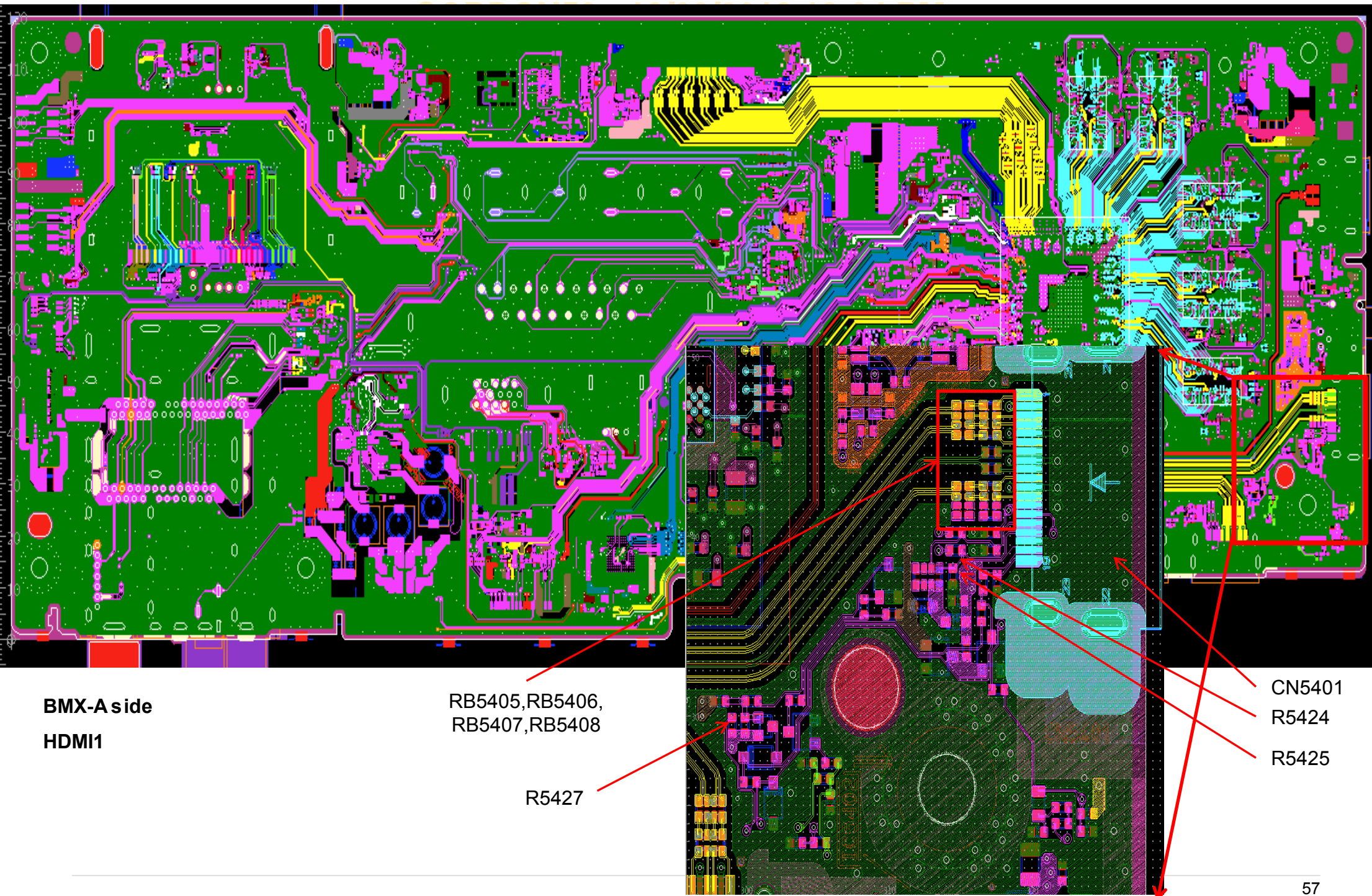

**BMX-A side**  
**HDMI1**

RB5405, RB5406,  
RB5407, RB5408

R5427

CN5401  
R5424  
R5425

### 3-4-6. NO PICTURE: HDMI2

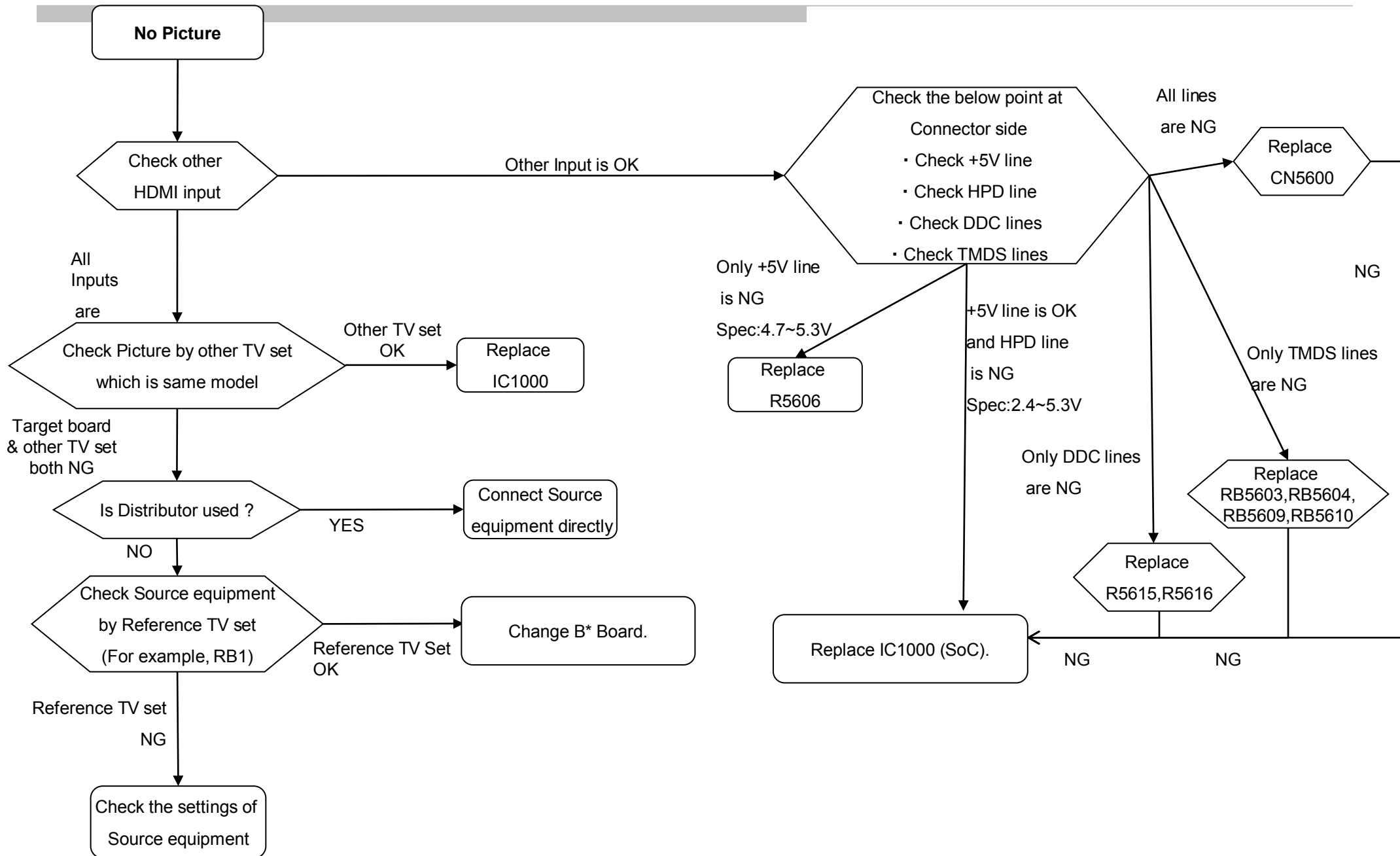



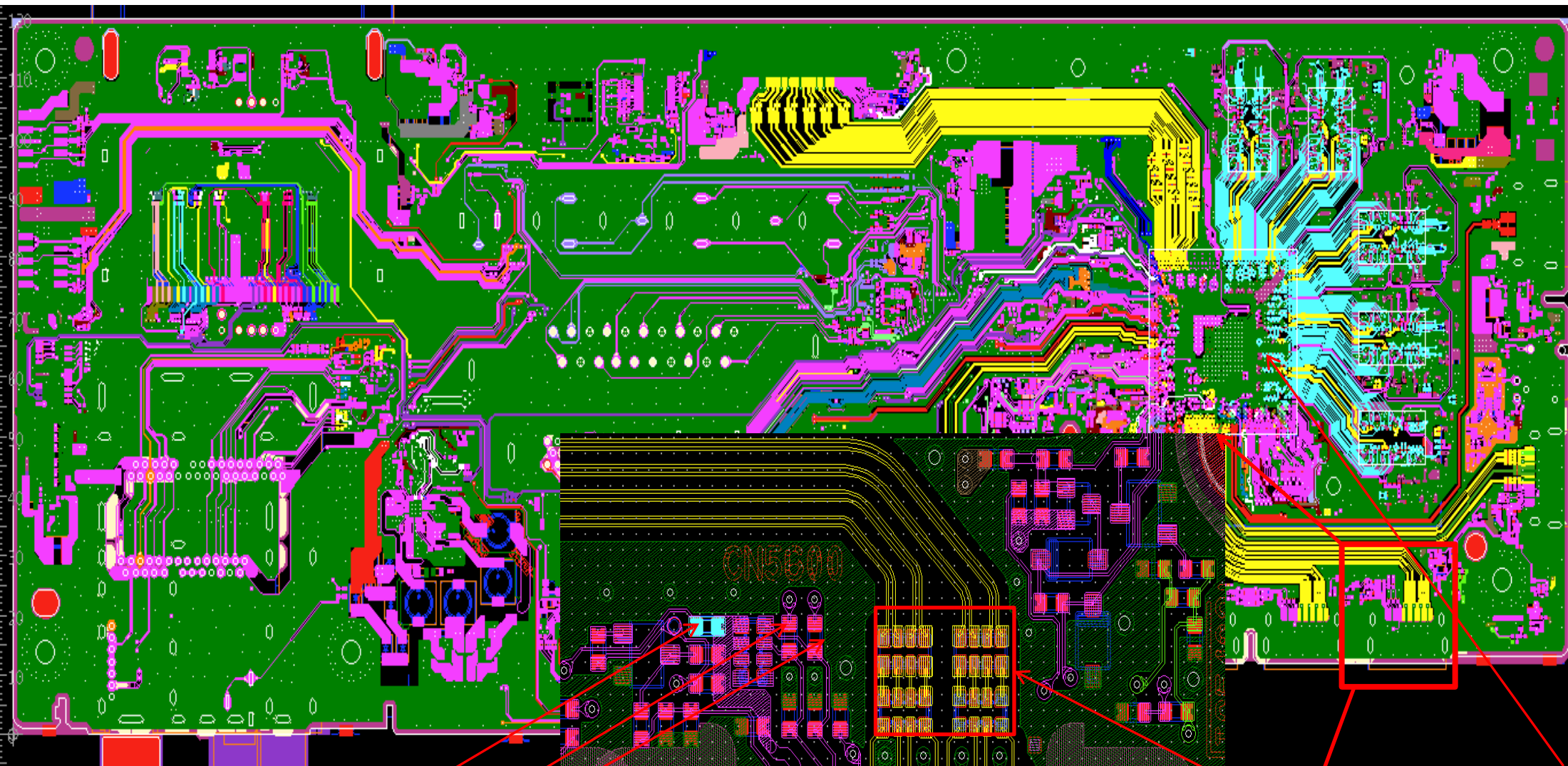

**BMX-A side**

**HDMI2**

R5606

R5616

R5615

CN5601

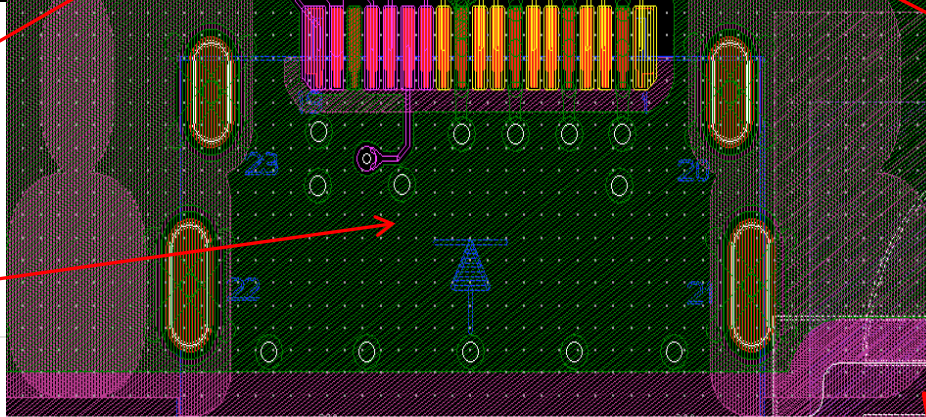

IC1000

RB5603, RB5604,  
RB5609, RB5610

### 3-4-7. NO PICTURE: HDMI3

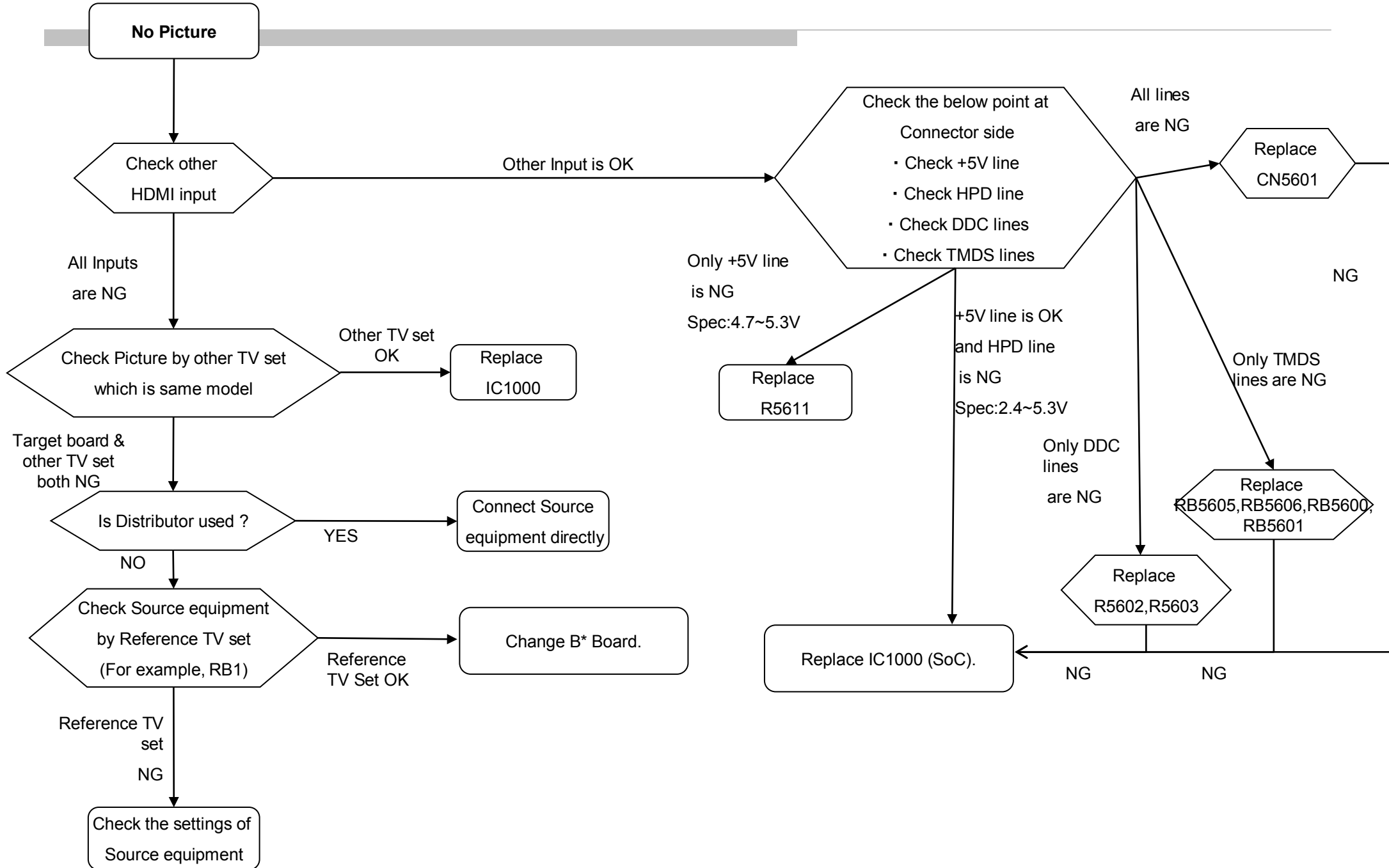



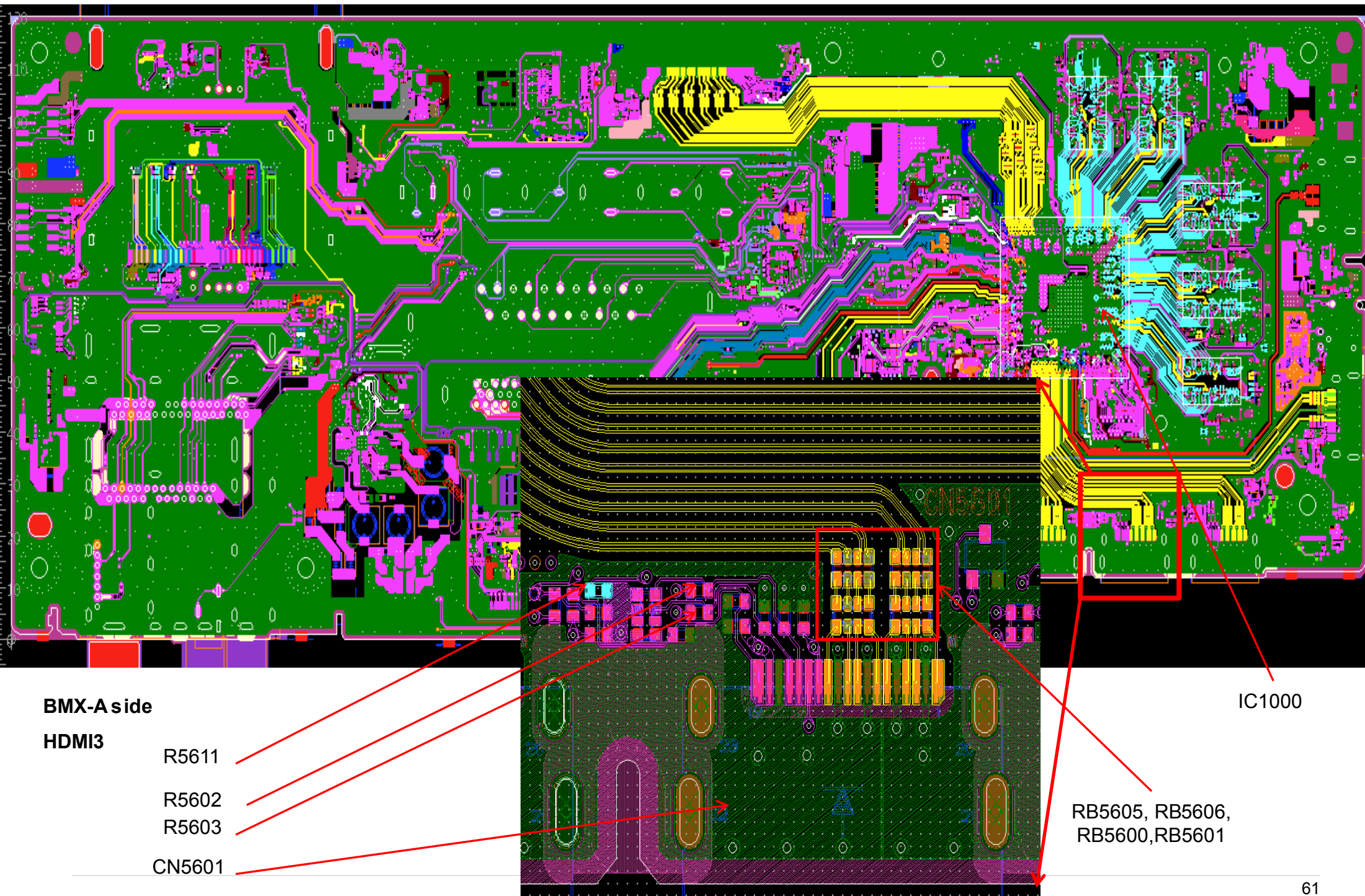

**BMX-A side**

**HDMI3**

R5611

R5602

R5603

CN5601

IC1000

RB5605, RB5606,  
RB5600, RB5601

### 3-4-8. NO PICTURE: HDMI4

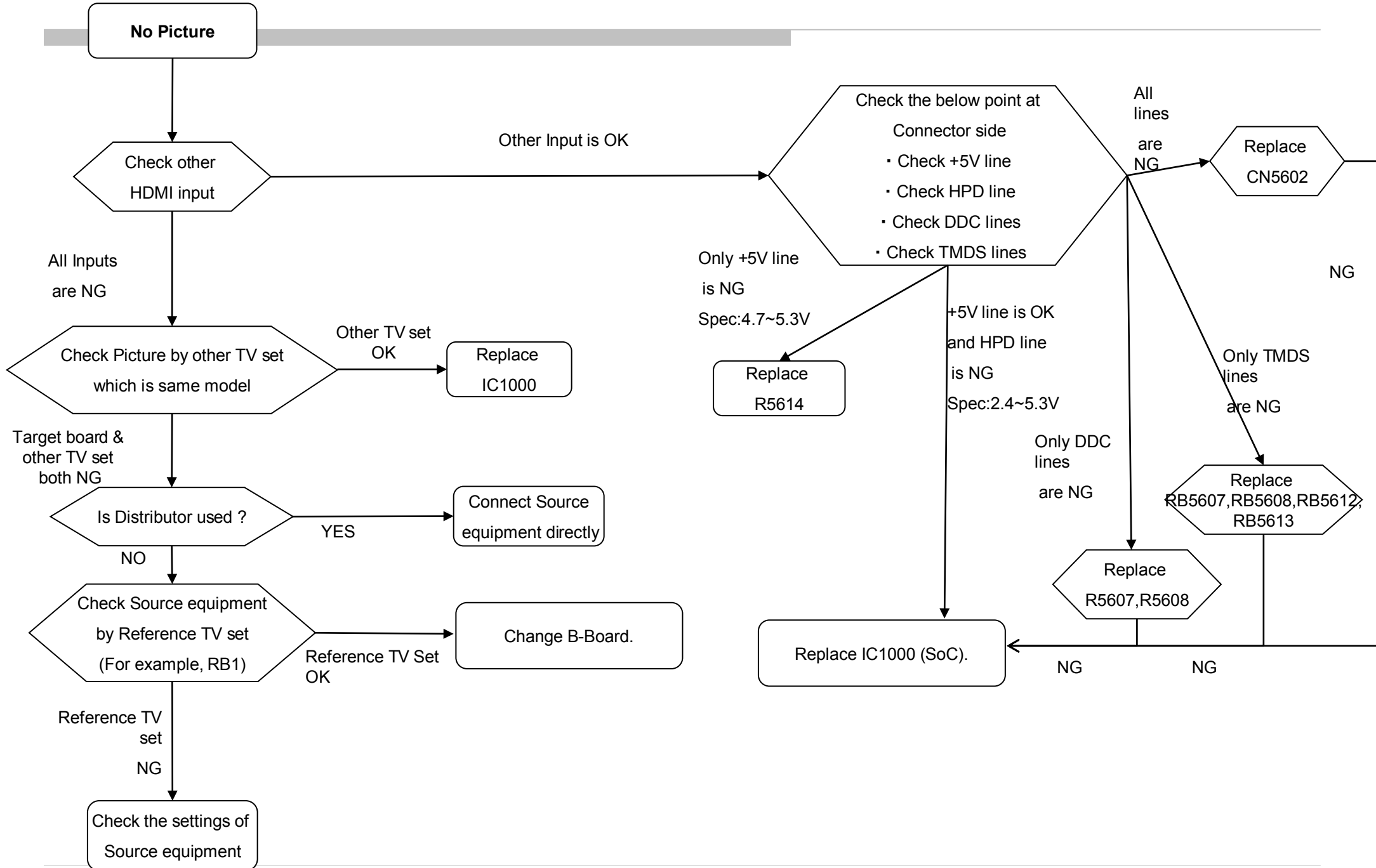



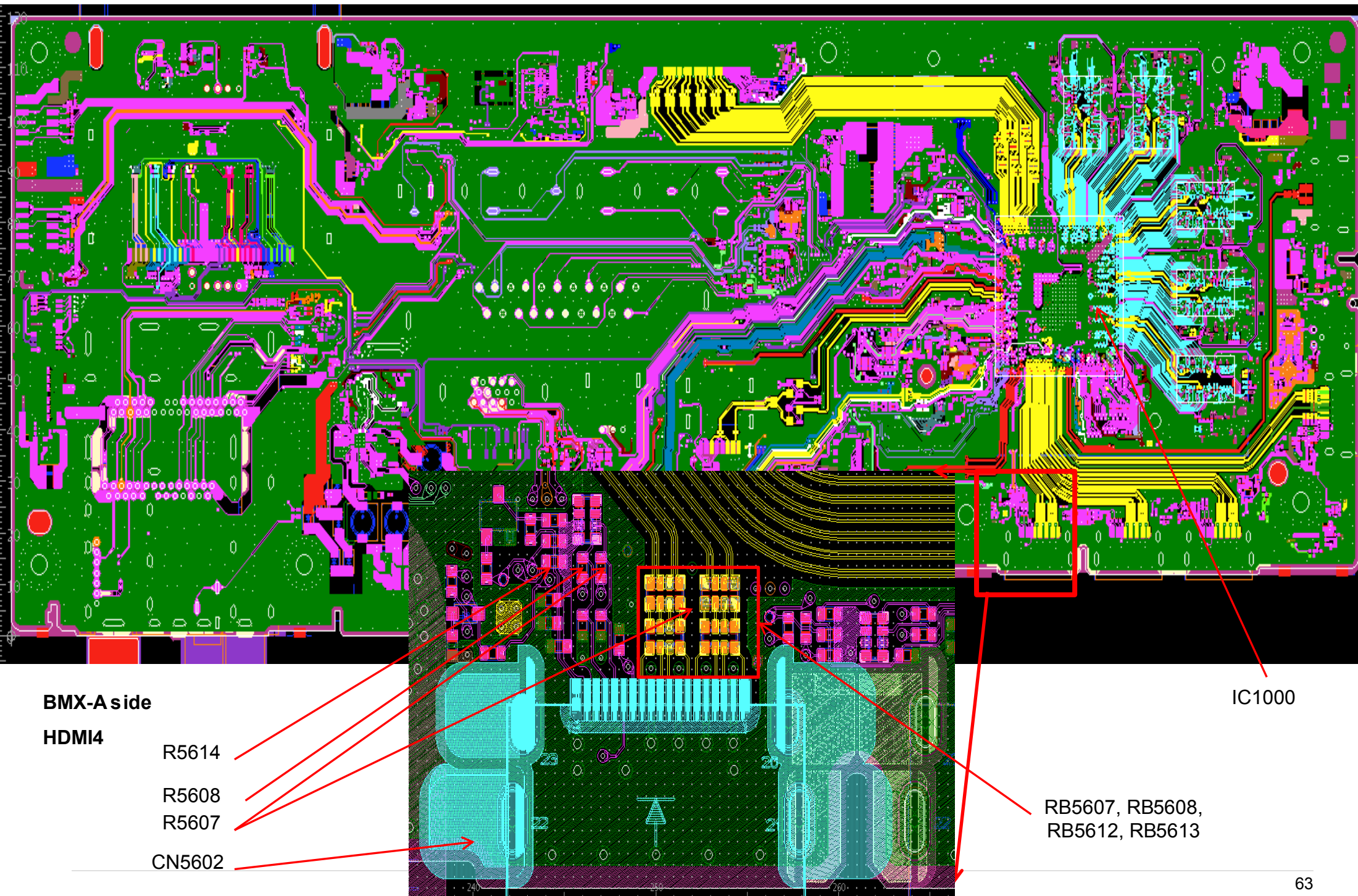

**BMX-A side**

**HDMI4**

R5614

R5608

R5607

CN5602

IC1000

RB5607, RB5608,  
RB5612, RB5613

### 3-4-9. NO PICTURE: MHL (BMX)

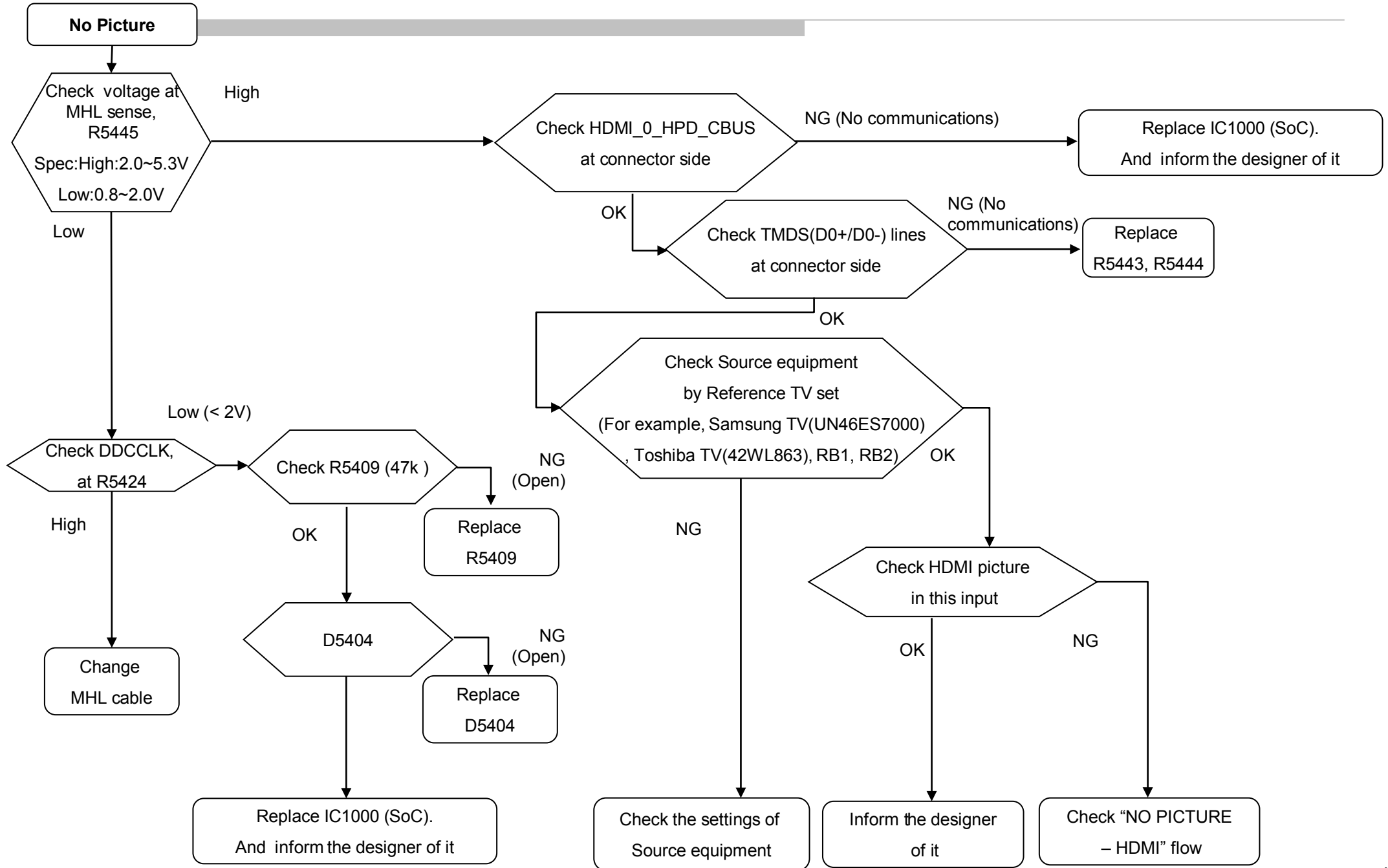



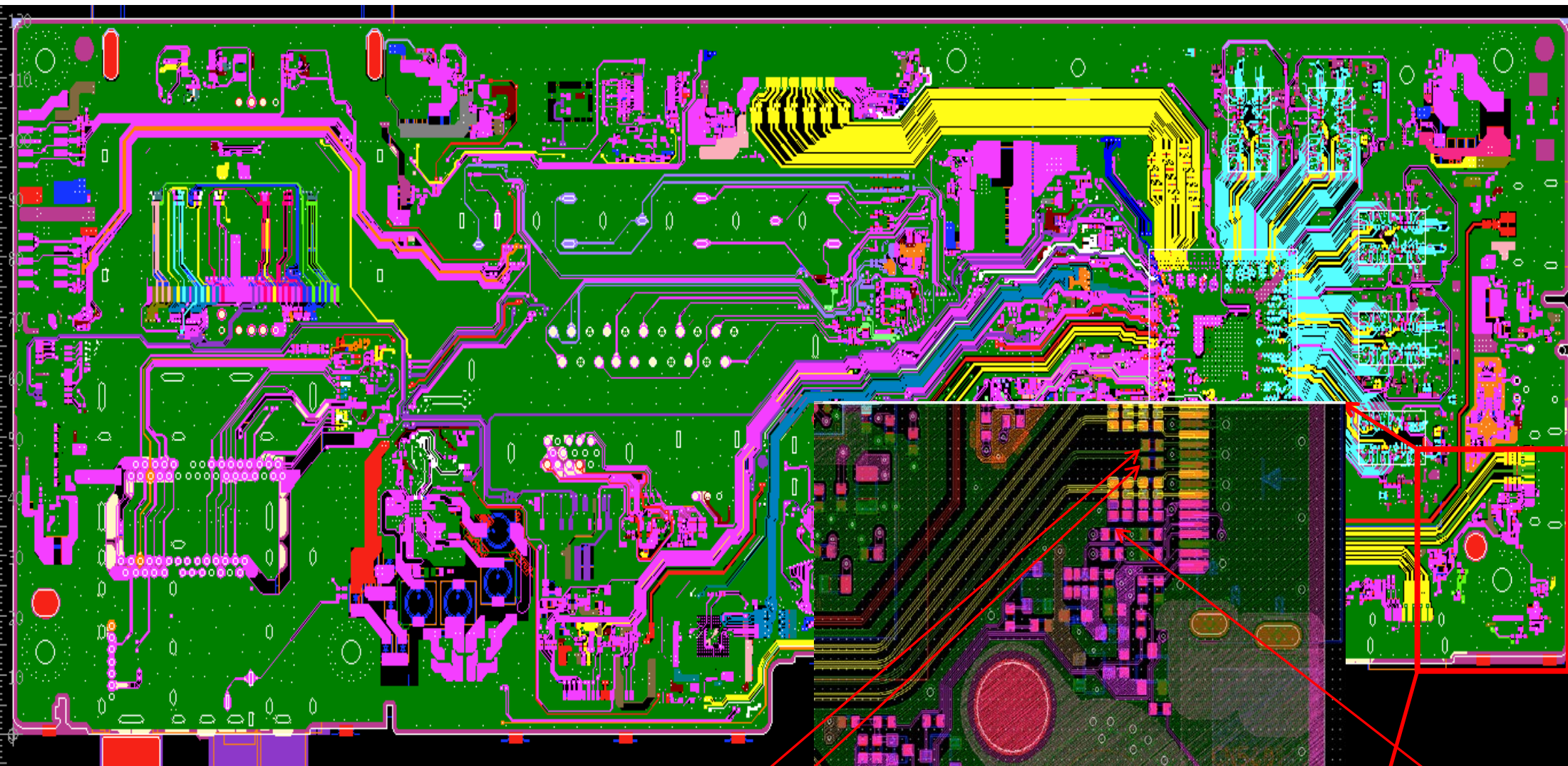

**BMX-A side**

R5443

R5444

R5445

R5424

### 3-5. SIDE BUTTONS MALFUNCTION

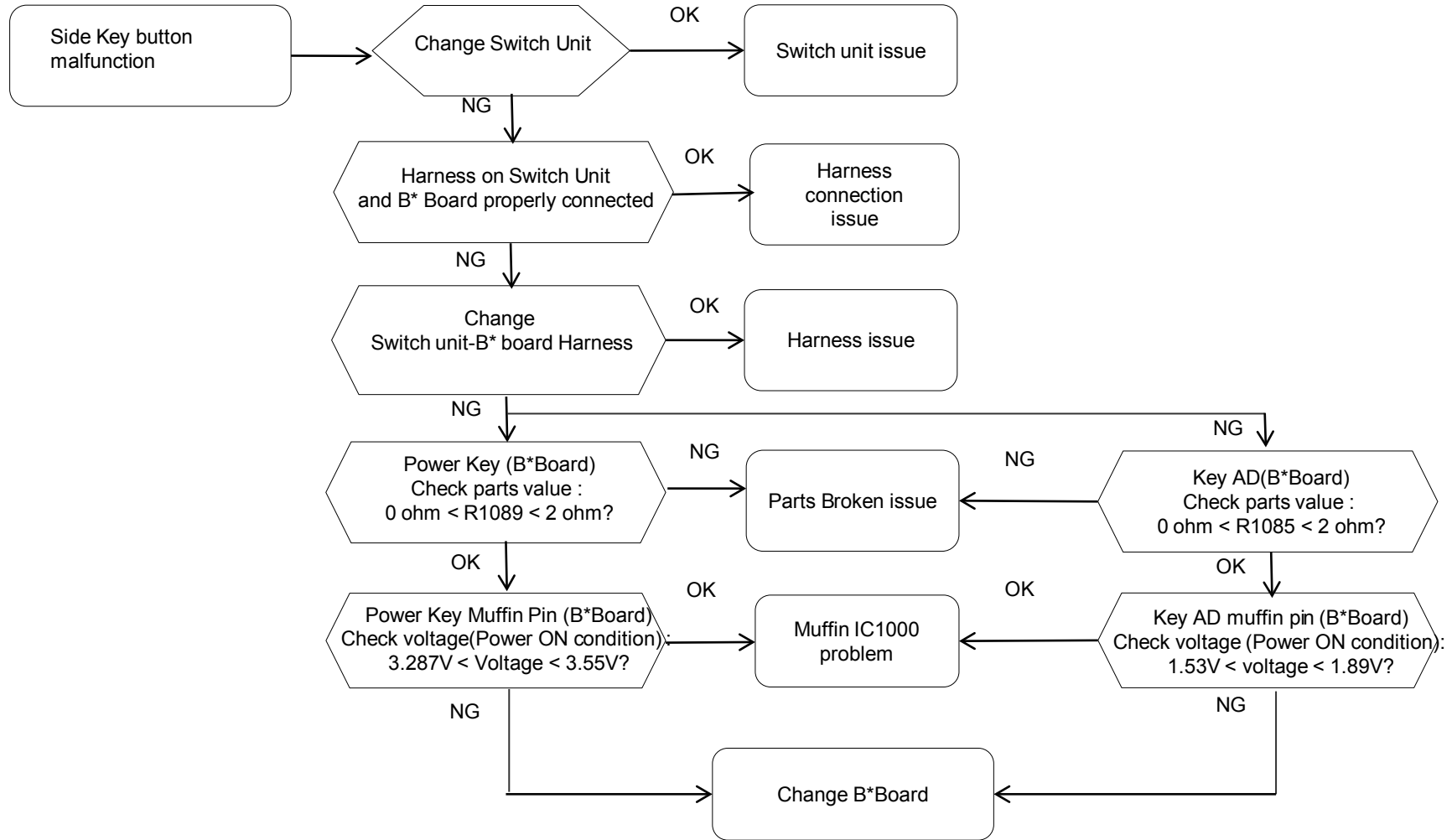



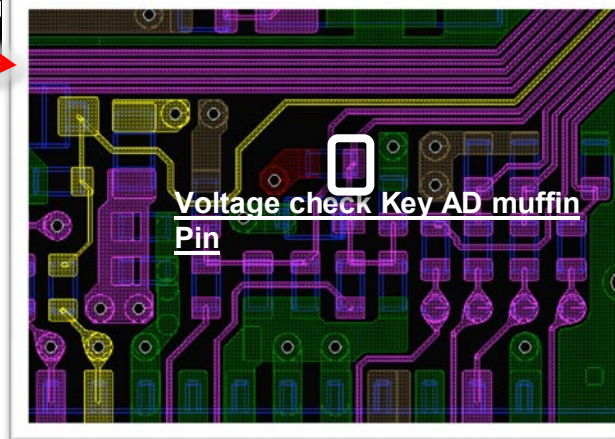
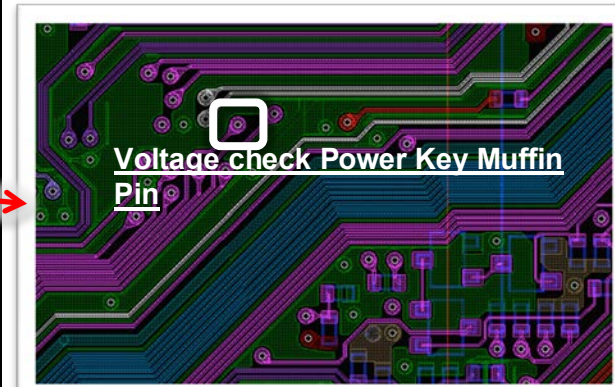
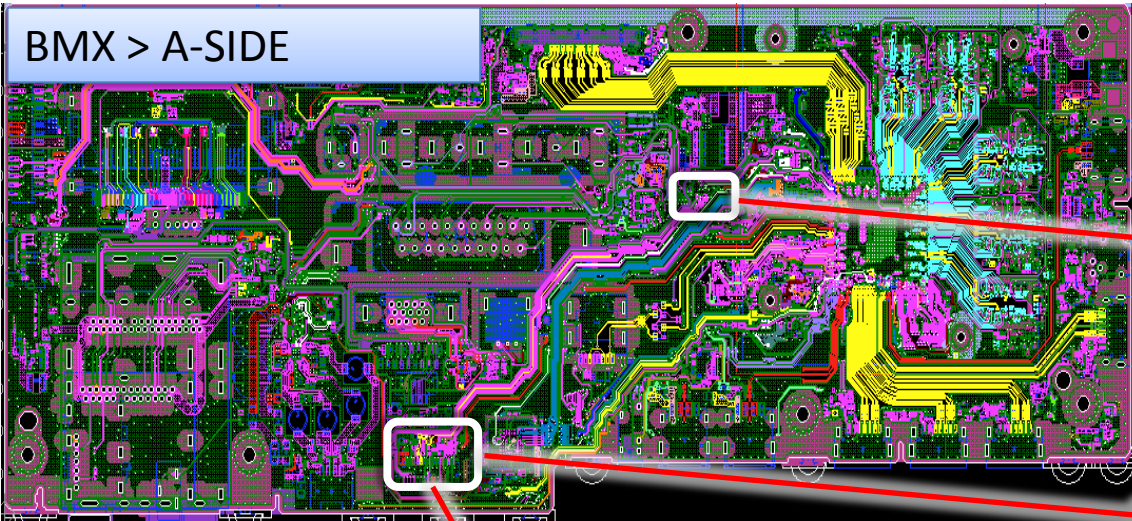

CORDON59 12/20/2018 12:04 PM

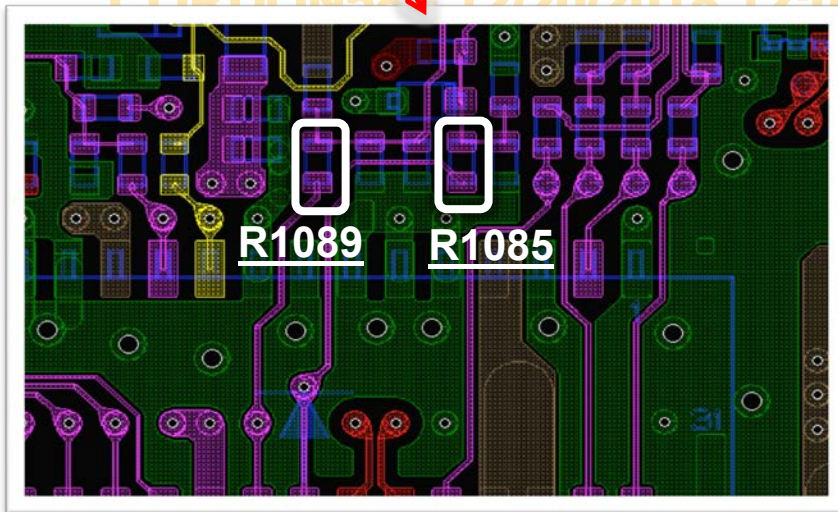

### 3-6. IR REMOTE COMMANDER MALFUNCTION

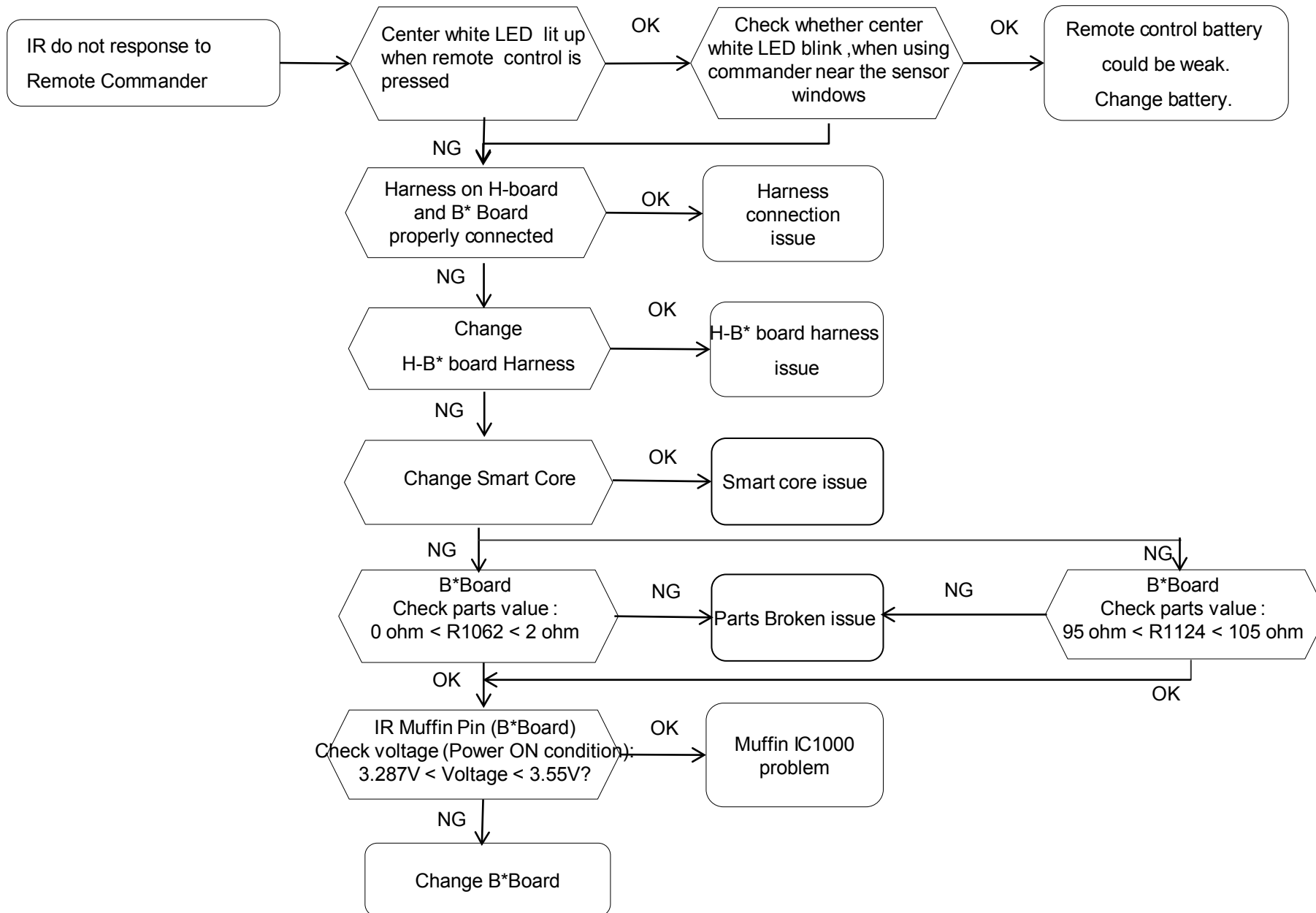



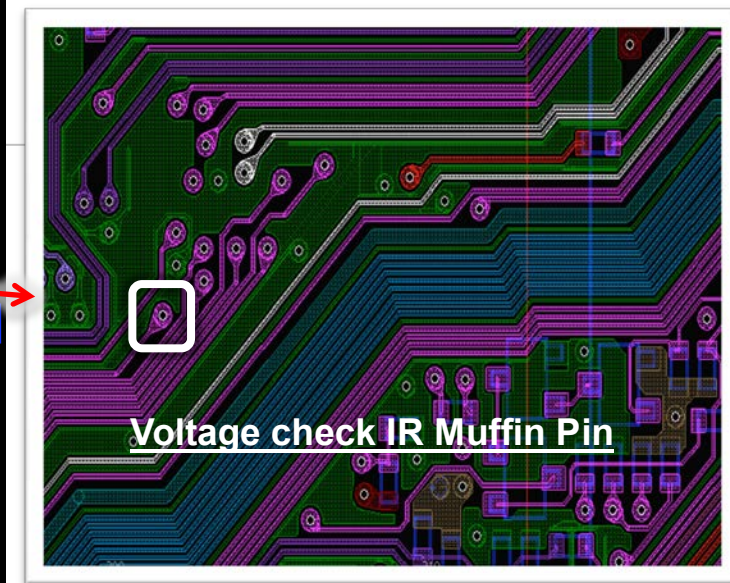
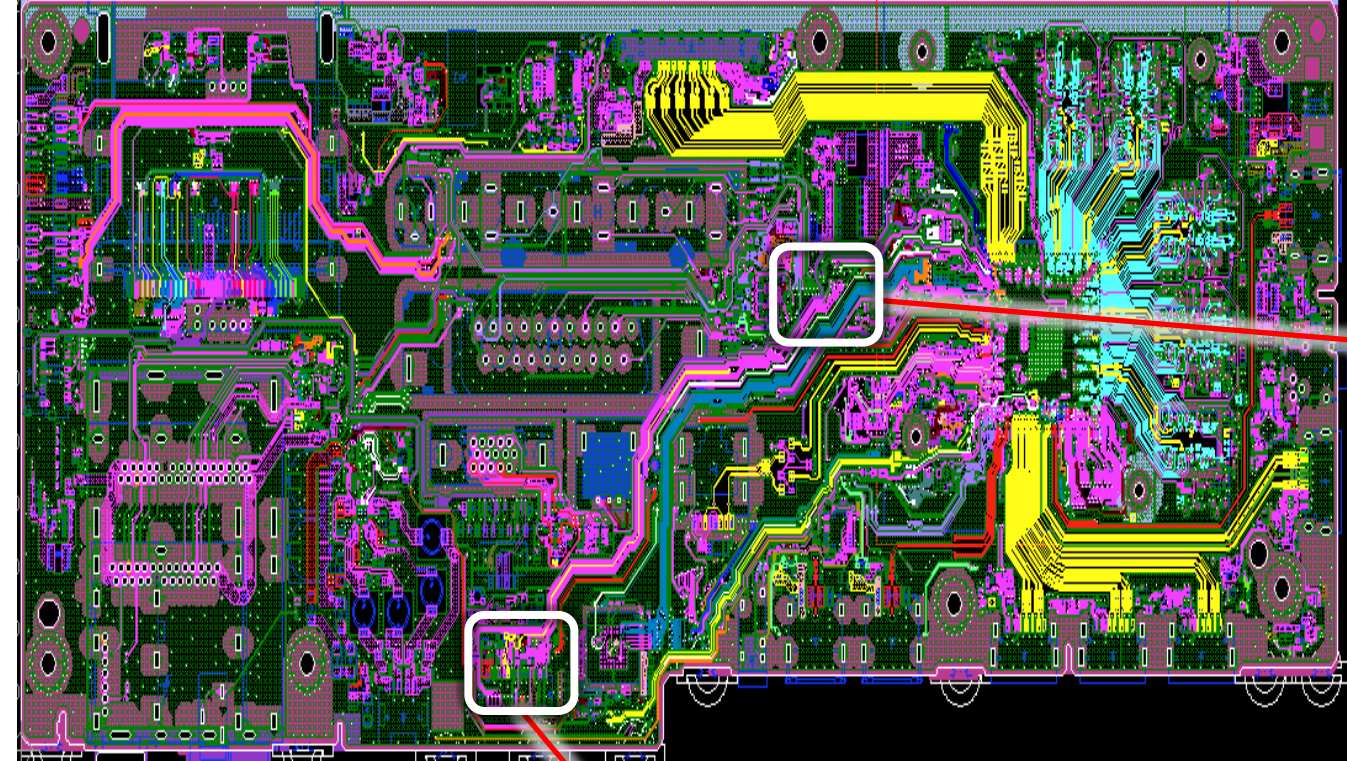

**BMX > A-SIDE**

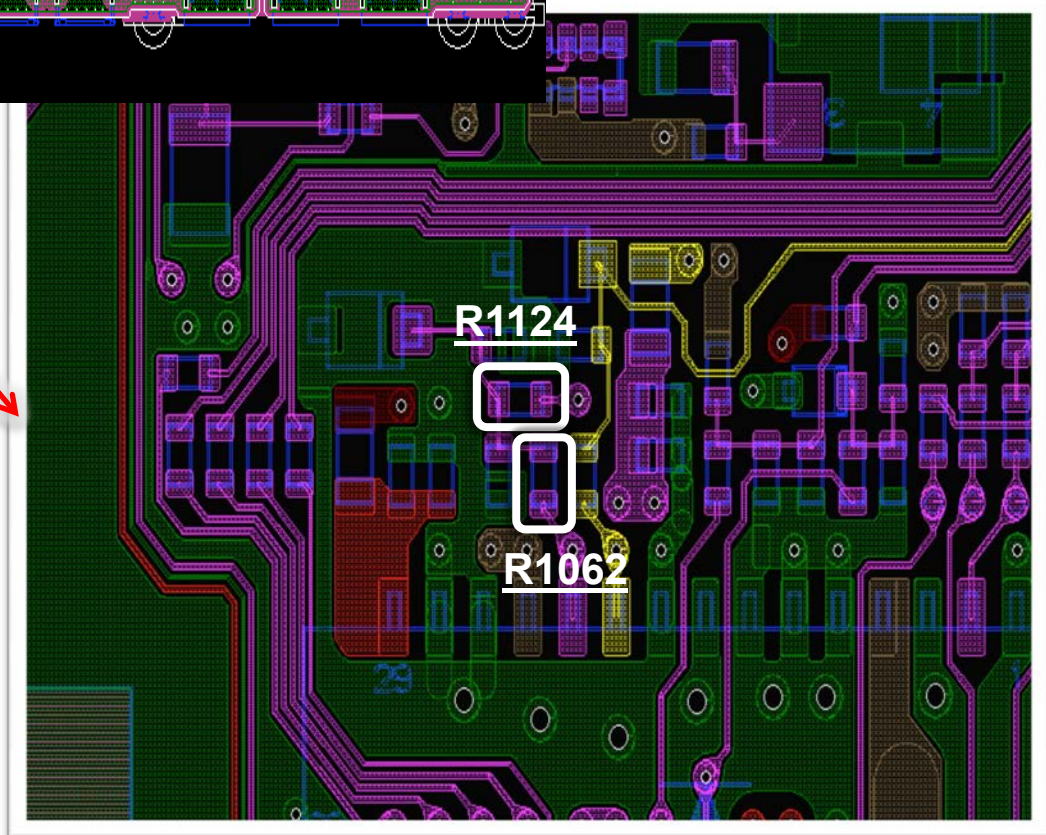

### 3-7. Light Sensor Error

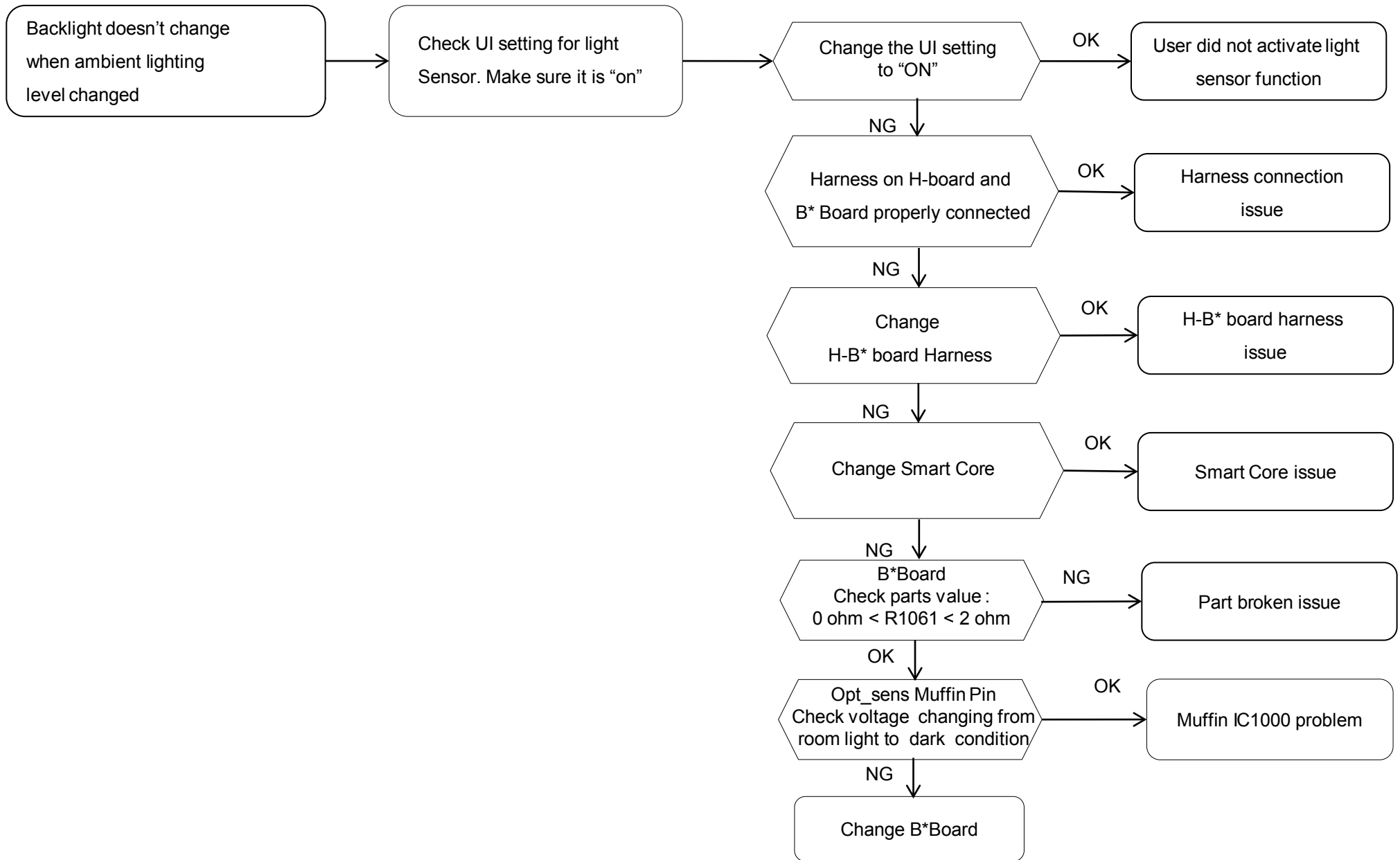



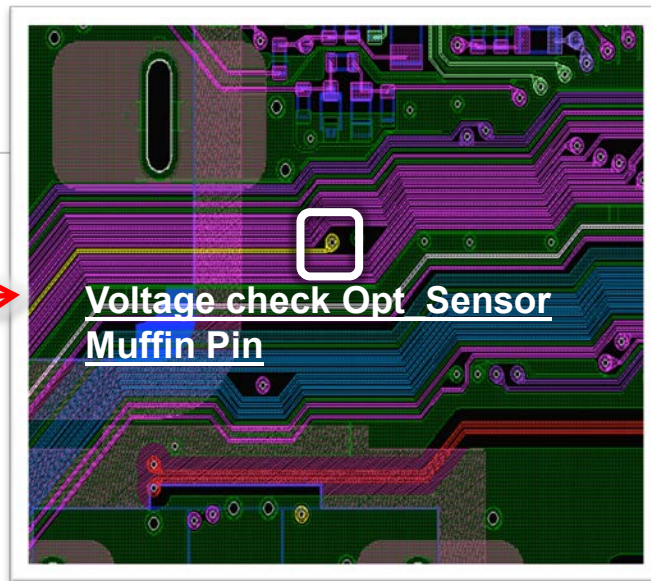
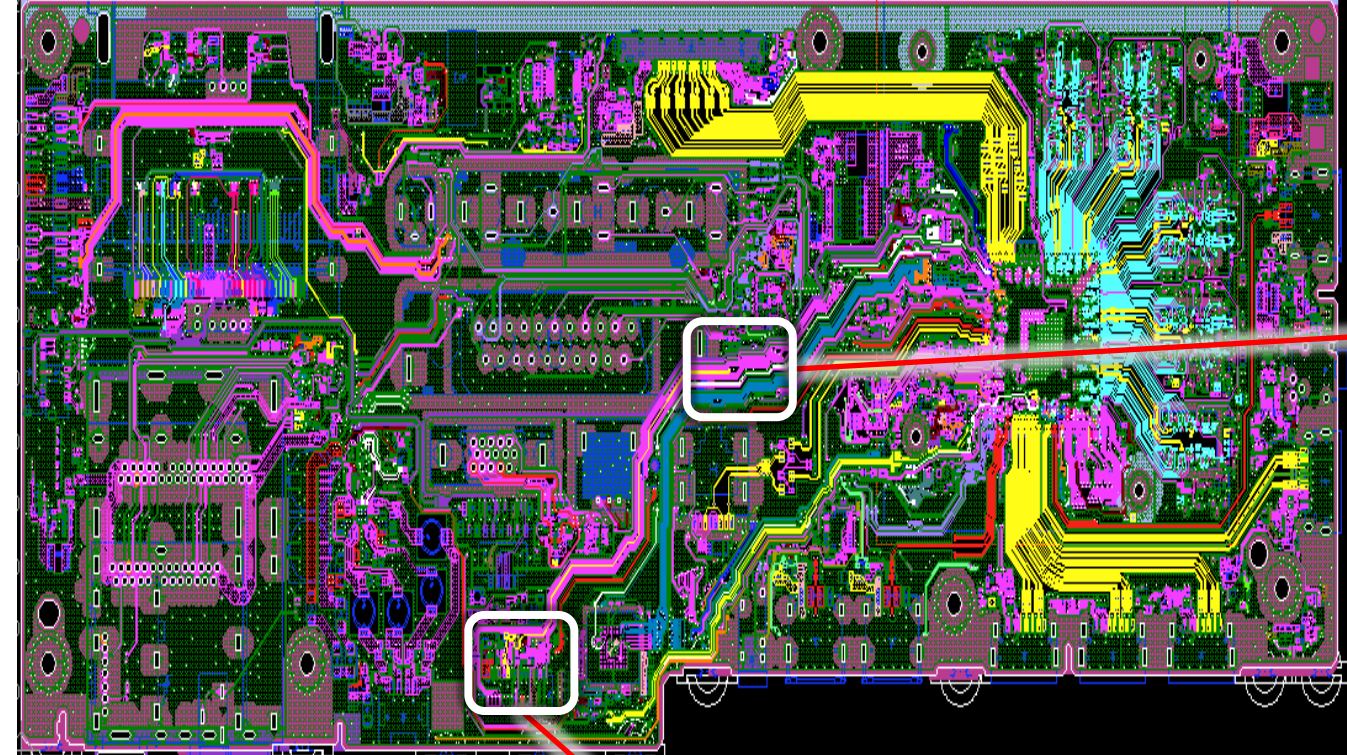

CORDON58 - 12/10/2018 12:04

BMX > A-SIDE

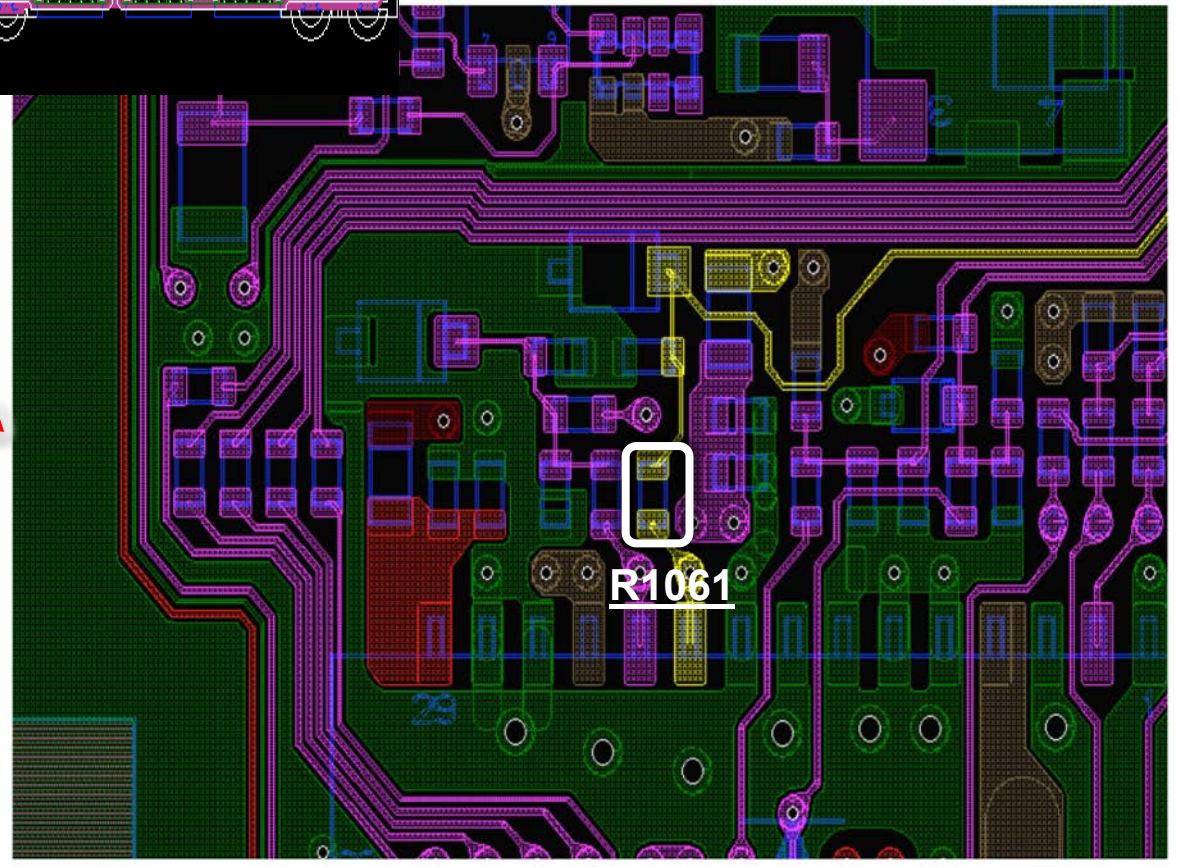

R1061

### 3-8. Network Malfunction: Ethernet (Wired)

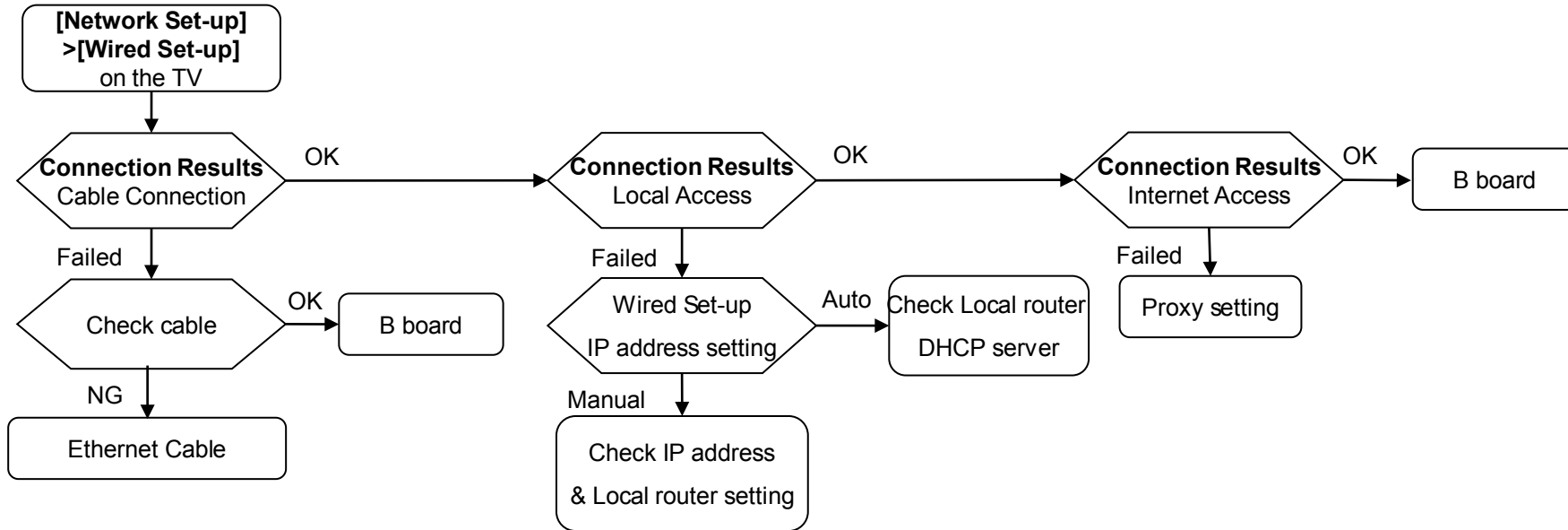



3-9. Wireless Network malfunction (a)

1) Internal Wireless Network malfunction

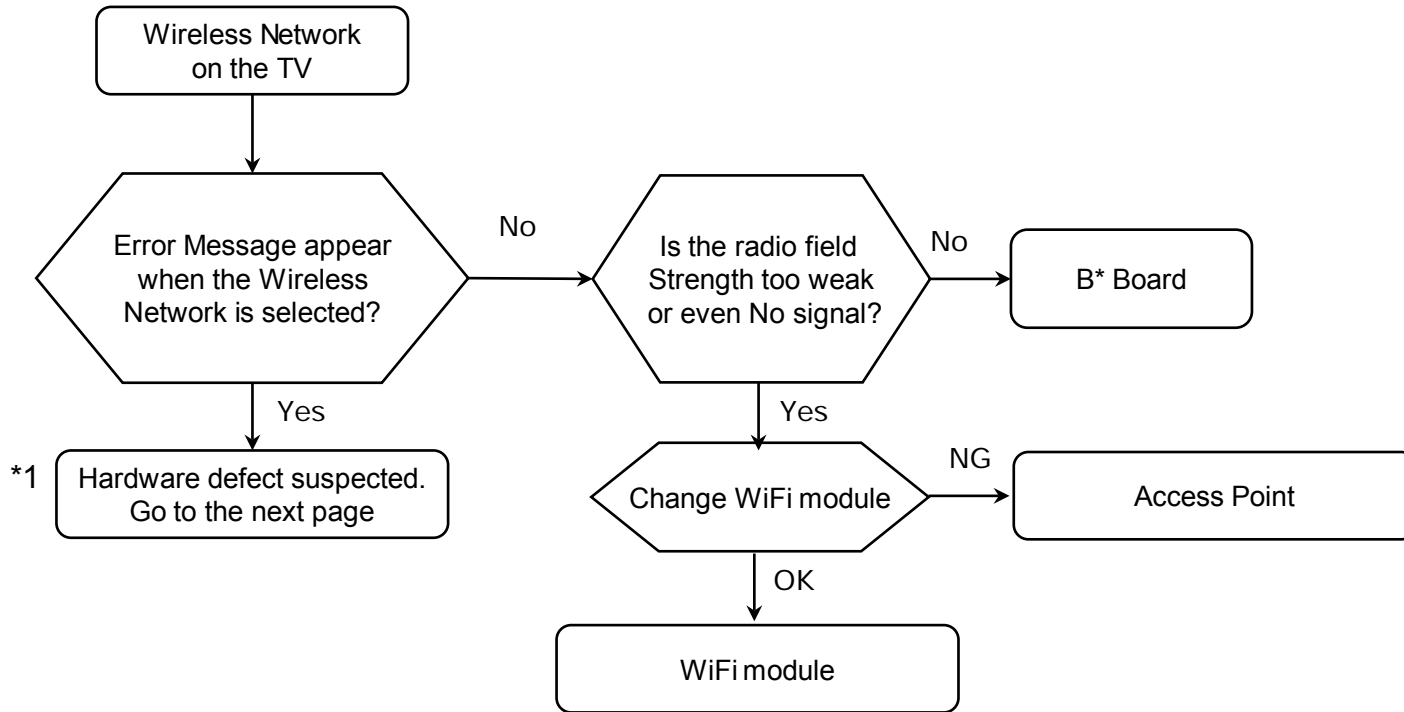

### 3-9. Wireless Network malfunction (b)

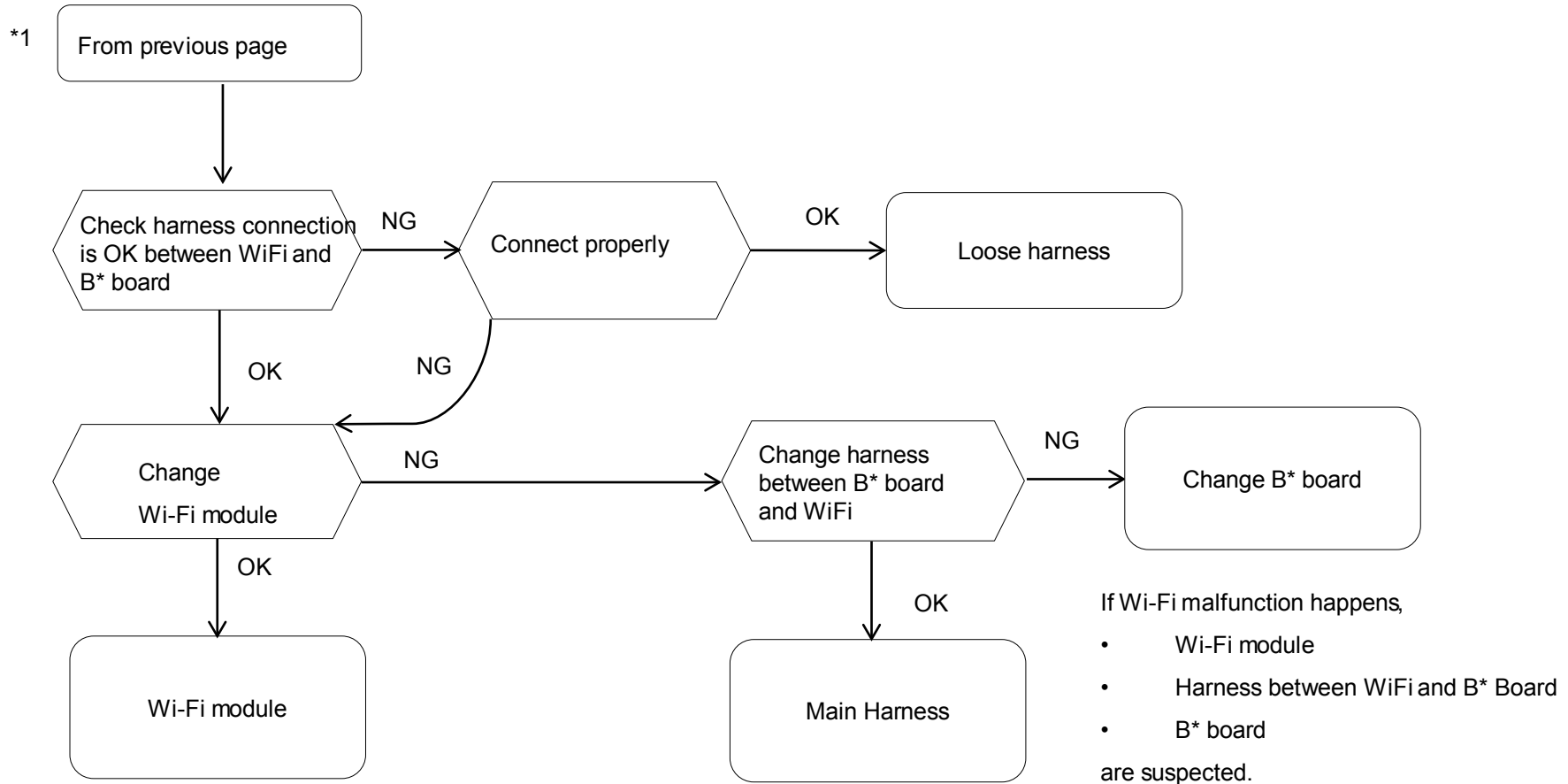

**Note: Board Details refer Section 3 main page.**

### 3-10. Bluetooth malfunction

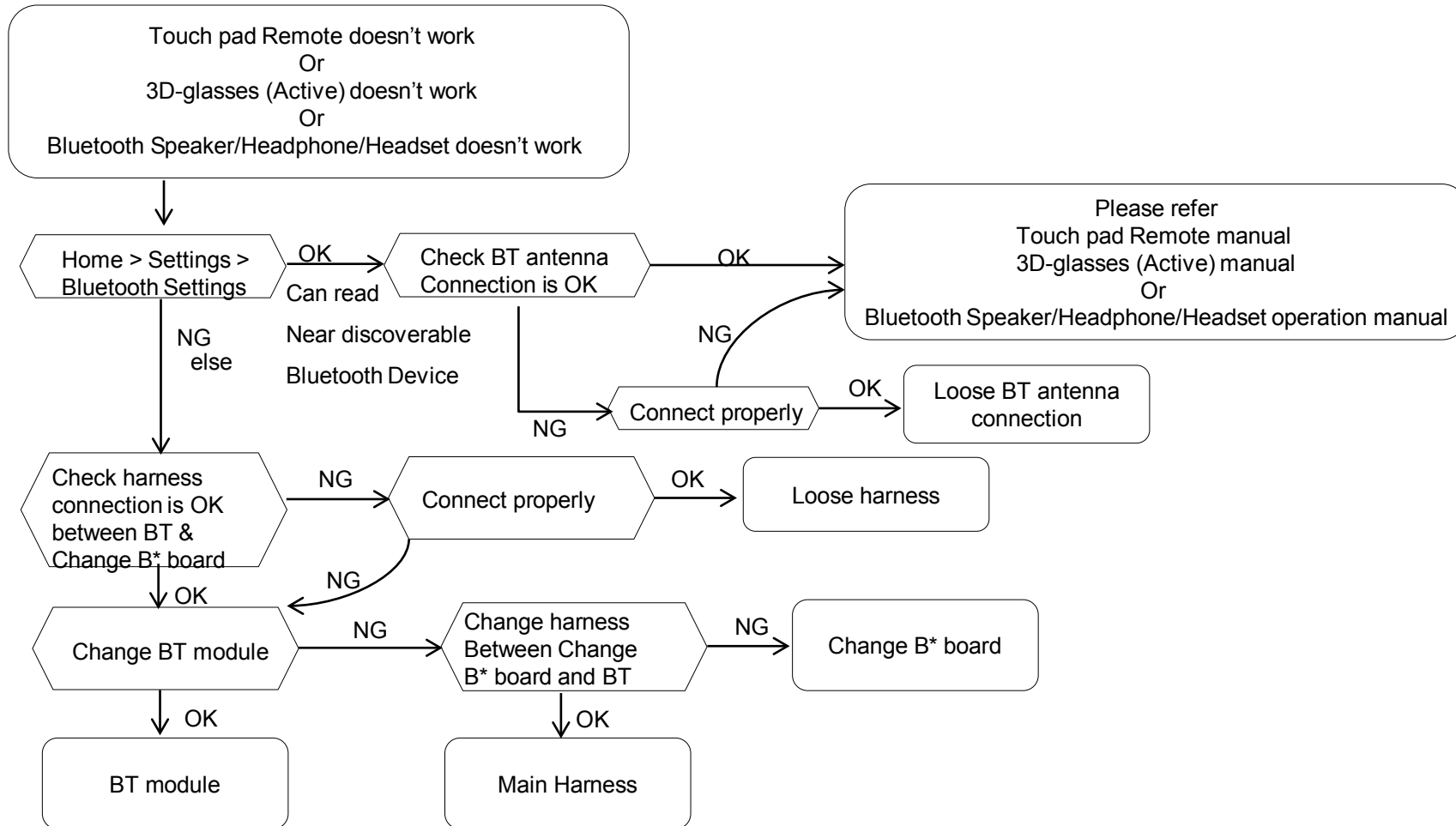



## SECTION 4 SERVICE ADJUSTMENTS

### Enter Service Mode

From Standby Mode

1. Go to TV standby condition by remote commander.
2. Press “i+ (info)/Display”, “5”, “Volume+” then “TV power” on remote.
3. You can see Service menu on display.

Remote Commander

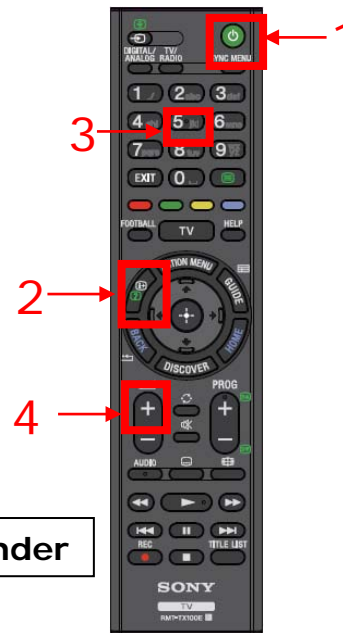

Service Mode

<b>Model Information</b>	>>
Self diagnosis History	>>
Video / Audio	>>
Panel / PQ	>>
General Setting	>>
Tuner	>>
Wifi / BT	>>
SDB Service Menu	>>

[</>] Set [Home]Exit

Service Menu

### Key Behavior Summary

Power	Power off (Stand by Mode)
Menu	Close service menu
Cursor/Enter	Return Previous page, Change portion of focus item, Enter next page of focus item, etc..
Return	Return to previous page, close service menu etc..

Note:

To completely exit Service Mode,

- 1) Press and hold “Power” key more than 5sec or
- 2) AC off/on

# Software Version

1) In Service Mode, select “Model Information”, press “Enter” or → button to enter **Status Information**

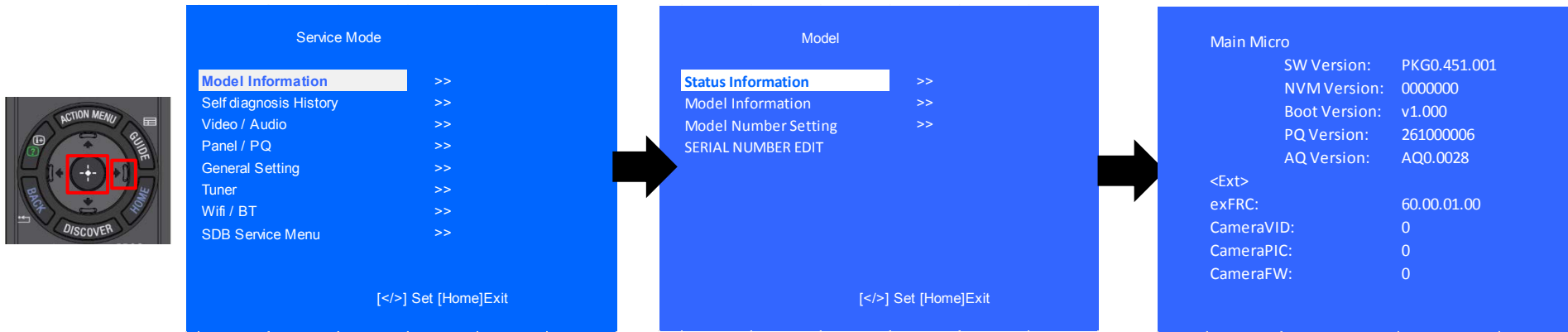

2) Press “Enter” or “Back” button to return to Service Mode

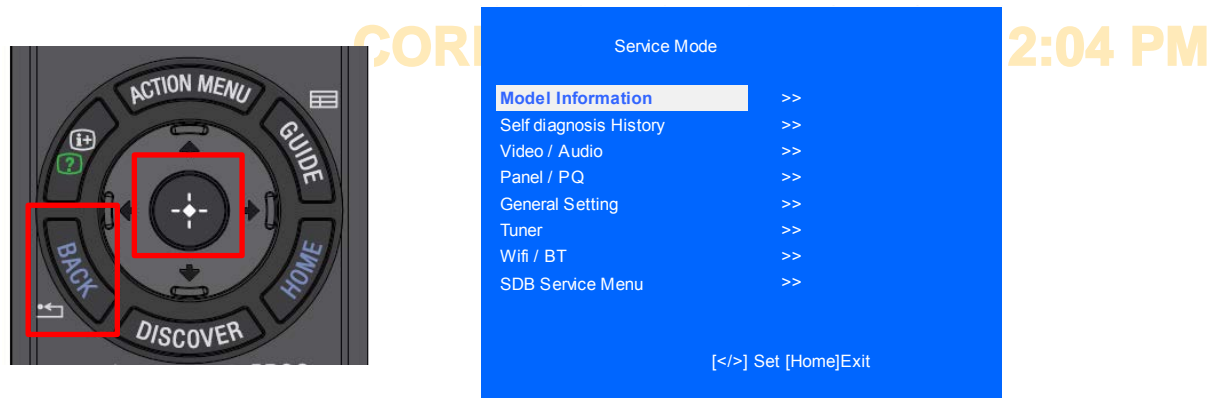

## Model Number Setting

- 1) In "Service Mode", select "Model Information" by pressing "→" or "Enter" button
- 2) Select "Model Number Setting" by pressing "→" or "Enter" button
- 3) Press "↑" or "↓" arrow key to scroll Product Name Candidate.
  - (e.g. KDL-40X500B CO1, KDL-40X500C BR6)
- 4) Select one Product Name from the list, press <Enter> and the cursor will move to "OK" button.
- 5) Press <Enter> if input data is correct. Model dependent settings will be overwritten into EEPROM.
- 6) Press "↑" to select again if input data is incorrect.

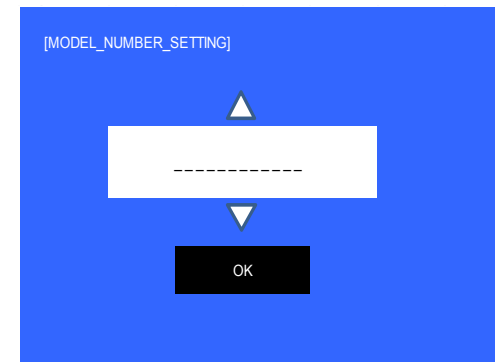
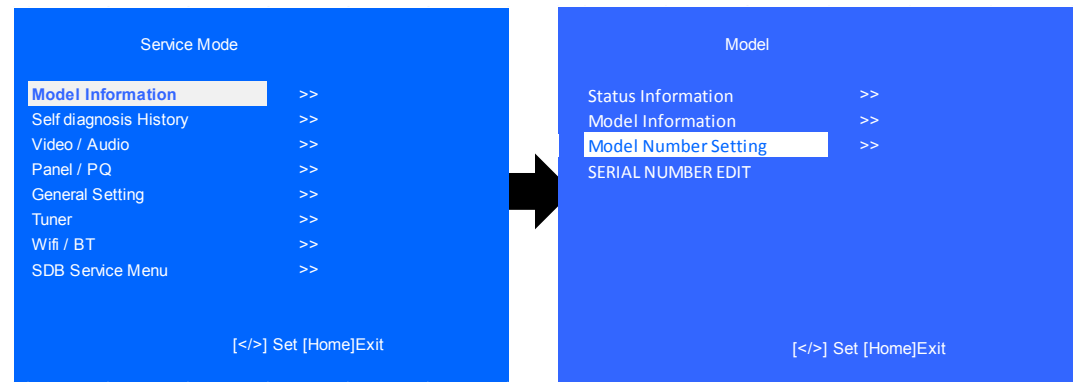



## Serial Number Edit (1)

- 1) In "Service Mode", select "Model Information" by pressing "→" button
- 2) Select "Serial Number Edit" by pressing "→" button
- 3) Press "↑" or "↓" to input numbers
- 4) After user input data , press <Enter>
  - Pop-up dialog appear to confirm input data correct
  - Serial Number can be set ONLY ONCE**
- 6) Press "→" or "←" button to select YES or NO. Select YES if input data is correct. Select NO if input data is incorrect. Press <Enter> to save answer.

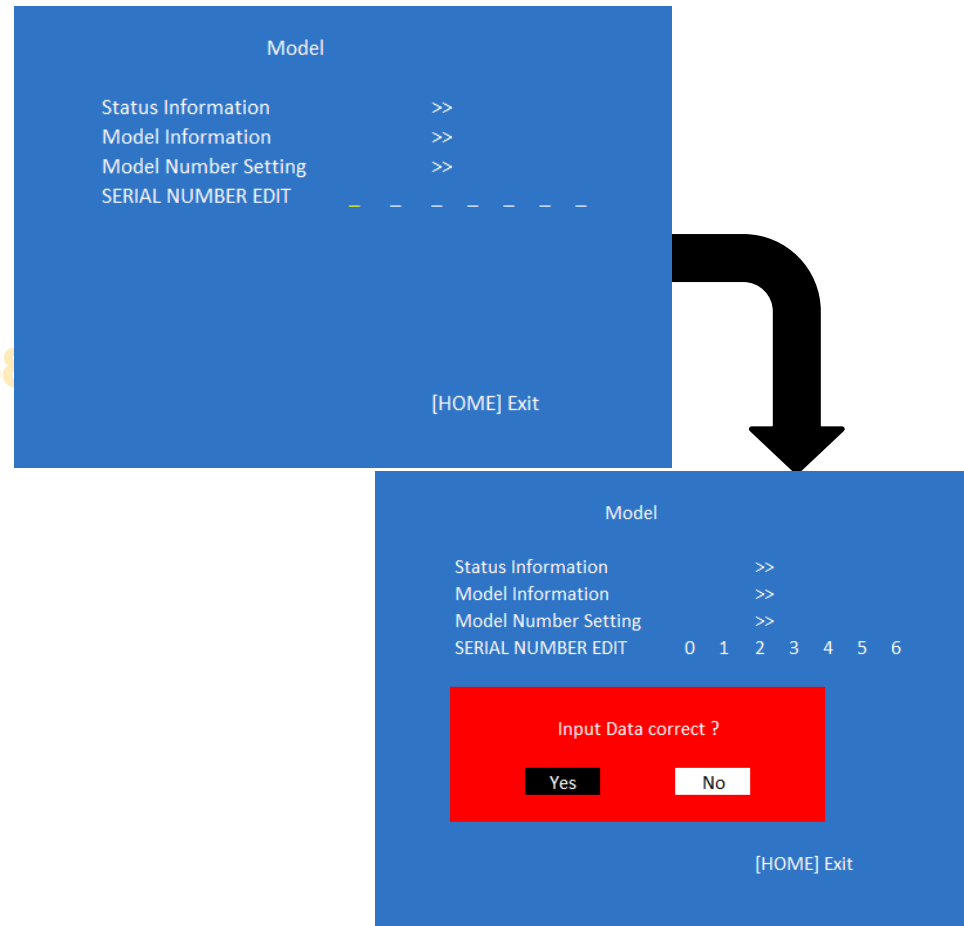

## Serial Number Edit (2)

- 5) If **YES is selected**, the input data is saved into EEPROM. SERIAL NUMBER EDIT is grayed out and the serial number that has been input is displayed. User will **not able to edit** anymore.
- 6) If **NO is selected**, the input data is not saved into EEPROM. The serial number that has been input is displayed. User can still edit the Serial Number.

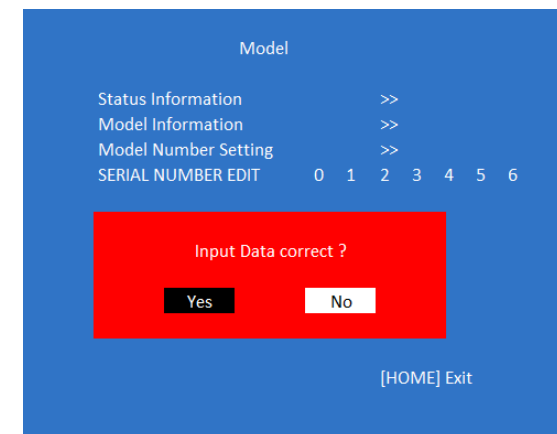
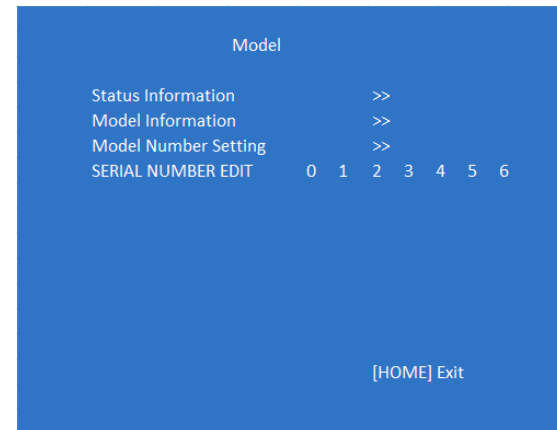

## HDD Performance Check

- 1) In "Service Mode", select "General Setting" by pressing "→" button
- 2) Select "HDD Performance check" by pressing "→" button
- 3) A message "Please wait ..." is displayed during performance check processing.
- 4) Result **OK** or **NG** will be displayed after performance of HDD is checked

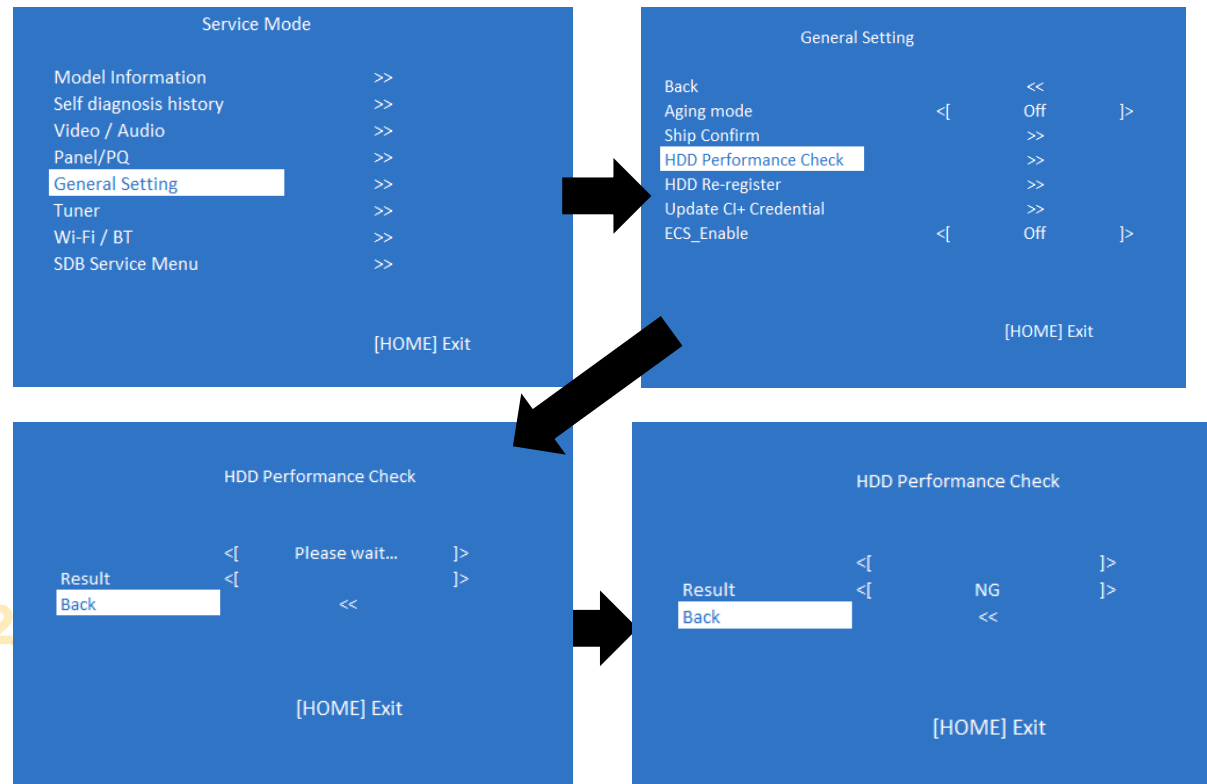

CORDON58 - 12

## HDD Re-Register

- 1) In “Service Mode”, select “General Setting” by pressing “→” button
- 2) Select “HDD Performance check” by pressing “→” button
- 3) Result **OK** or **NG** will be displayed after HDD re-registration is succeed/failed

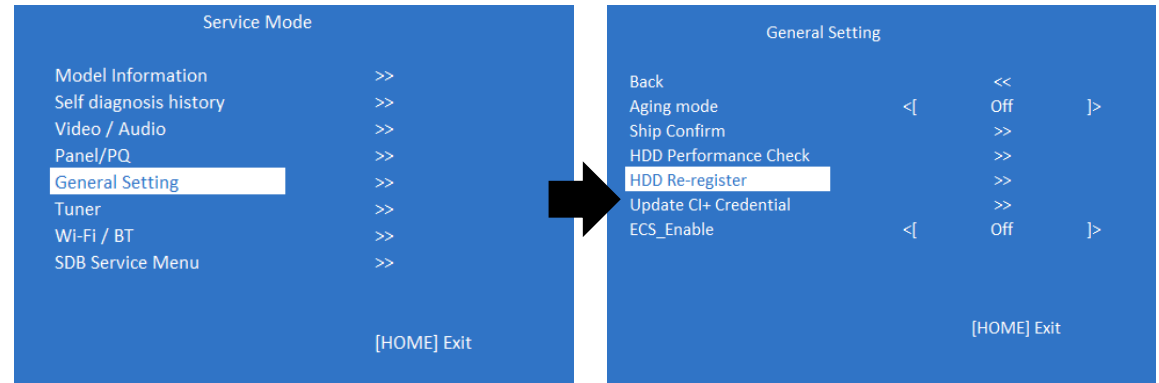



# WB Adjustment

Please apply Main board or panel is replaced.

ON58 - 12/20/2018 12:04 PM

1. In **“Panel/PQ”** service mode
  - a. Go to **“WB Adjustment”** category by “↑” or “↓”.
  - b. To select **“WB Adjustment”**, press → button.
  - c. To change data , press “←” or “→” on remote commander.



a.

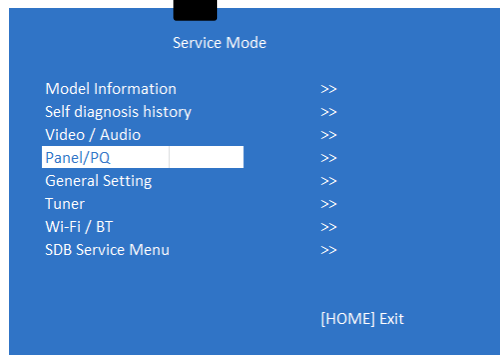

b.

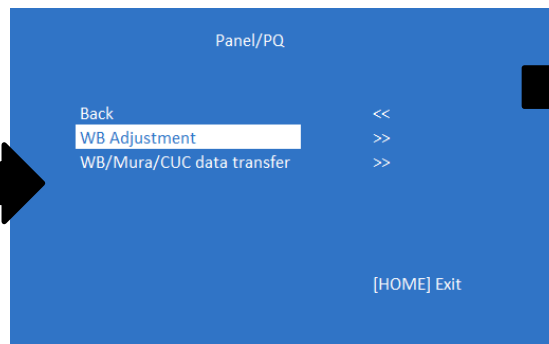

c.

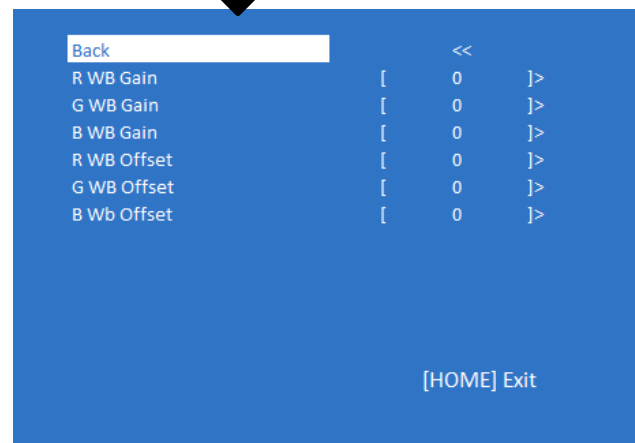

## WB/Mura/CUC data transfer

Please apply Main board or panel is replaced.

1. In “Panel/PQ” service mode
  - a. Go to “**WB/Mura/CUC data transfer**” category by “↑” or “↓”.
  - b. To select “**WB/Mura/CUC data transfer**”, press → button.
  - c. To change data , press “←” or “→” on remote commander.

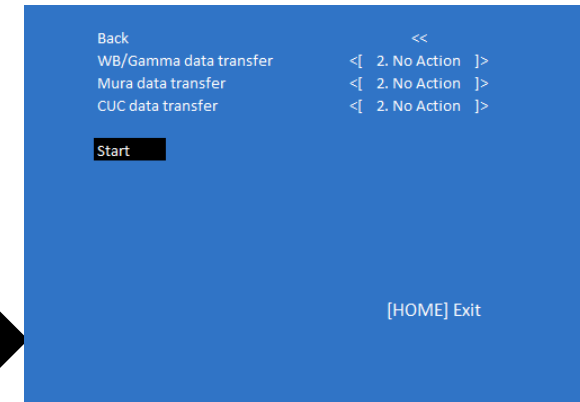
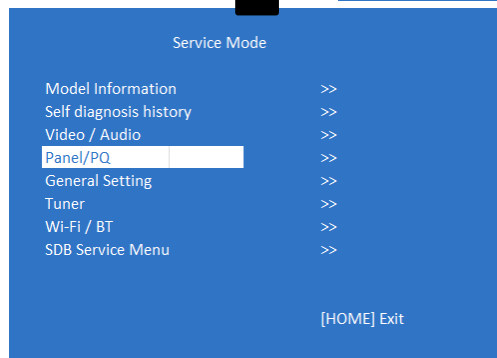
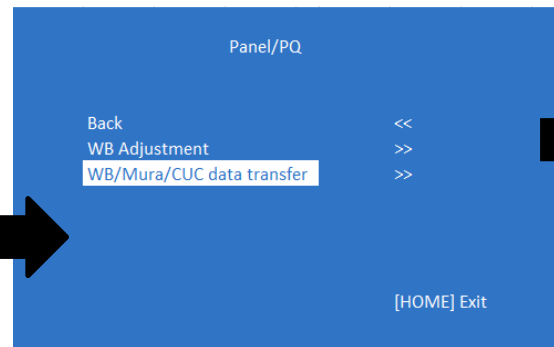

2. In “WB/Mura/CUC data transfer”

- a. Select “**WB/Gamma data transfer**” by pressing “↑” or “↓” on remote commander until cursor is on “**WB/Gamma data transfer**”.

Selectable items are:

- 0. SoC to T-con
- 1. T-con to SoC
- 2. No Action

- b. To change the items, press “←” or “→” on remote commander.
- c. Select “[start]” and press “Enter” button to start transfer.

## Summary of Service Control

Function	The flow of control
Service mode on	<Display> <5> <Vol Up> <Power>
Service mode off	<MENU>/<HOME>
Item up / down	<↑>/ <↓>
Execute (実行)	<Enter>

### Note:

To completely exit Service Mode,

- 1) Press and hold "Power" key more than 5sec or
- 2) AC off/on

## How to Enter Self Diagnosis Display

### Go to Self diagnosis history through Service Mode

1. Go to TV standby condition by remote commander.
2. Press “i+ (info)”, “5”, “Volume+” then “TV power” on remote.
3. Select “Self diagnosis history” by pressing “→” button
4. You can see Self Check.

The left screenshot shows the 'Service Mode' menu with the following options:

- Model Information >>
- Self diagnosis History >>
- Video / Audio >>
- Panel / PQ >>
- General Setting >>
- Tuner >>
- Wifi / BT >>
- SDB Service Menu >>

The right screenshot shows the 'SELF CHECK' screen with the following data:

Item	Count 1	Count 2	Count 3	Count 4
002 MAIN_POWER	000000000000	000000000000	000000000000	000
003 DC_ALERT	000000000000	000000000000	000000000000	000
003 AUD_ERR	000000000000	000000000000	000000000000	000
003 HDMI_EQ	000000000000	000000000000	000000000000	000
003 TU_DEMOD	000000000000	000000000000	000000000000	000
004 LD_ERR	000000000000	000000000000	000000000000	000
004 BCM_ERR	000000000000	000000000000	000000000000	000
005 TCON_ERR	000000000000	000000000000	000000000000	000
005 P_ID_ERR	000000000000	000000000000	000000000000	000
005 FRCTC_I2C	000000000000	000000000000	000000000000	000
006 BACKLIGHT_ERR	000000000000	000000000000	000000000000	000
007 TEMP_ERR	000000000000	000000000000	000000000000	000
007 4KBE_ERR	000000000000	000000000000	000000000000	000
008 SW_ERR	000000000000	000000000000	000000000000	000

At the bottom of the SELF CHECK screen, it displays: 00000 00000 00000 [Home]Exit

\*\* There will be no Self Diagnosis function for TU\_DEMOD. However, TU\_DEMOD item will remain in Self Diagnosis Display, the value count will not increase.



# SECTION 5 DIAGRAMS

CORDON58 - 12/20/2018 12:04 PM

## 5-1.CIRCUIT BOARD LOCATION

5-1-1. 65"

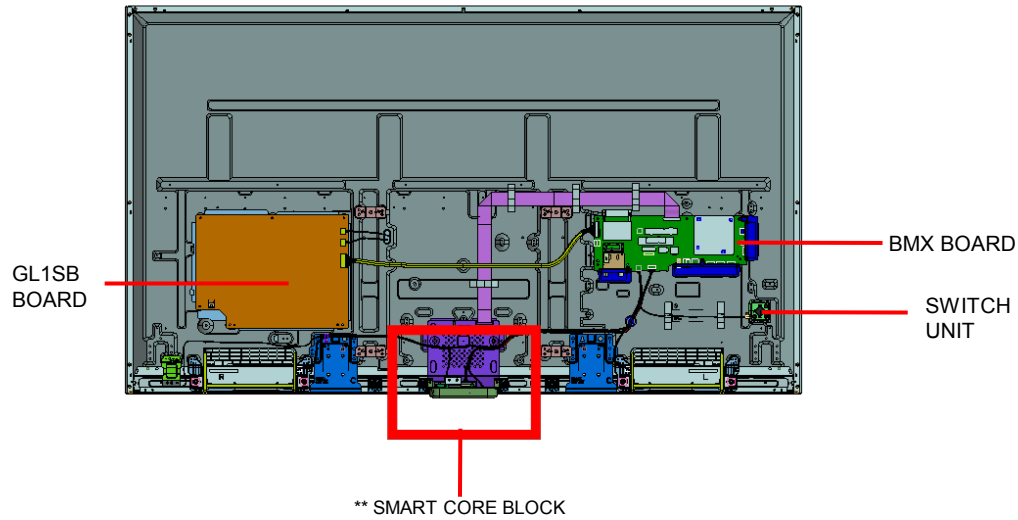

5-1-2. 75"

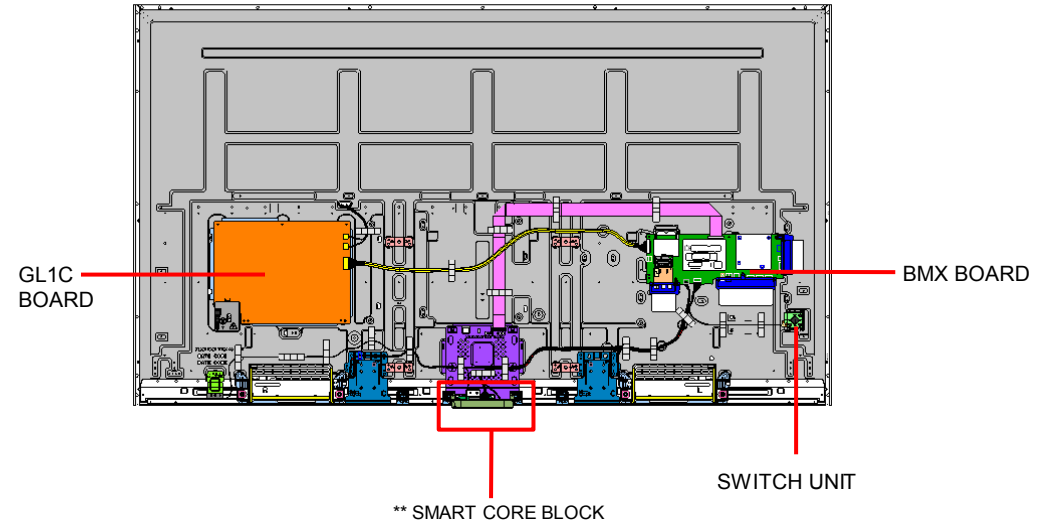

<\*\* SMART CORE BLOCK >

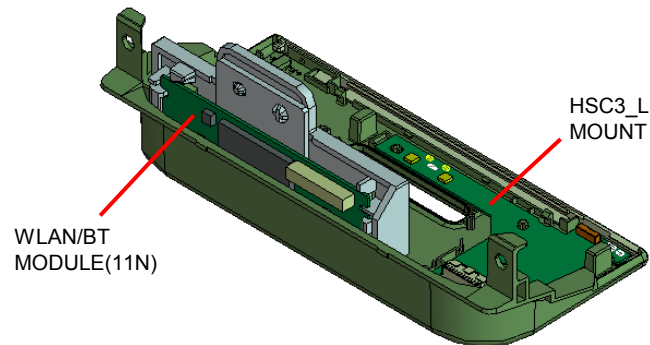

## 5-2. Block Diagram

### 5-2-1. XM-H model (AEP based)

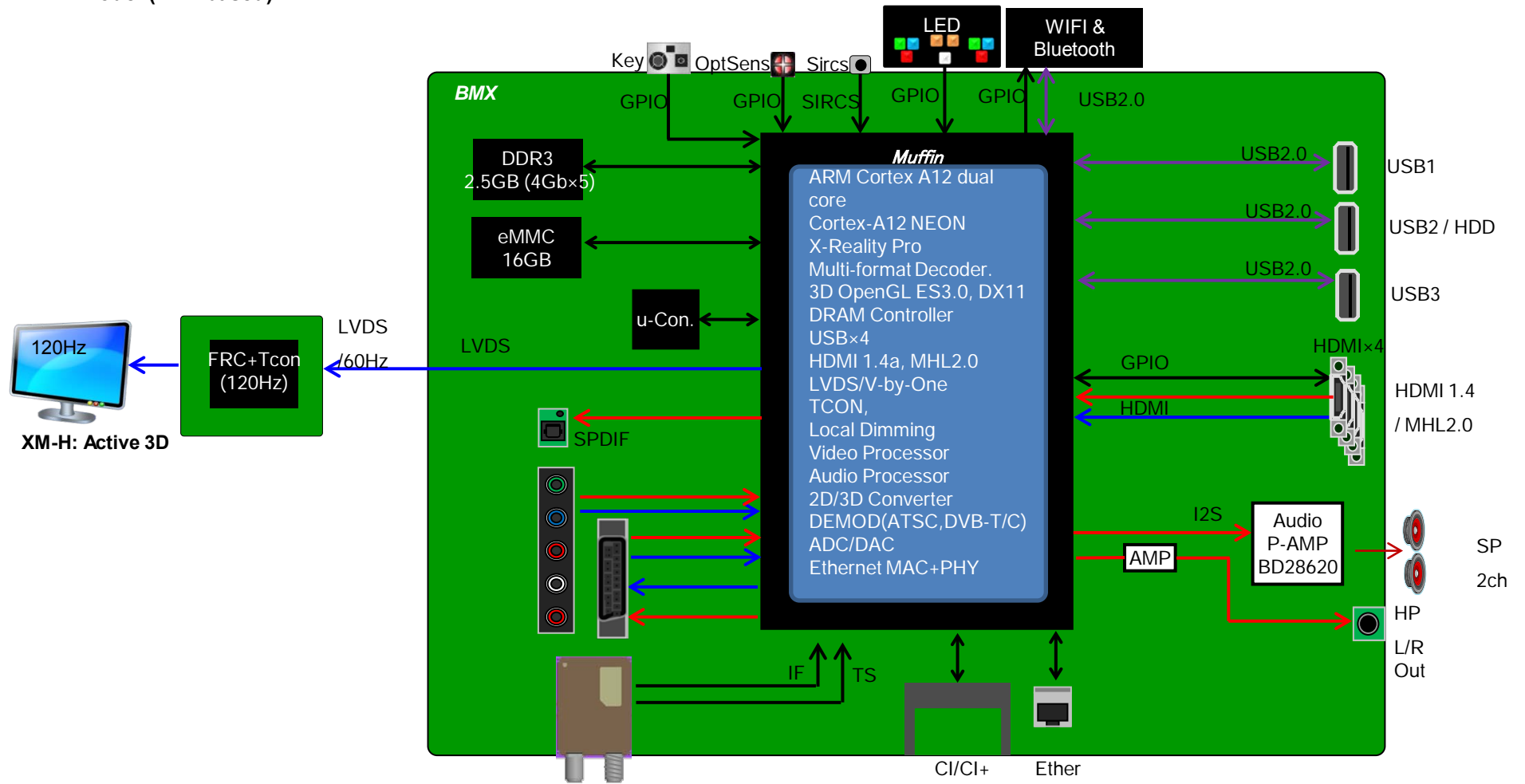

## 5-2. Block Diagram

### 5-2-2. XM-H model (BR,AR,LA\_ISDB)

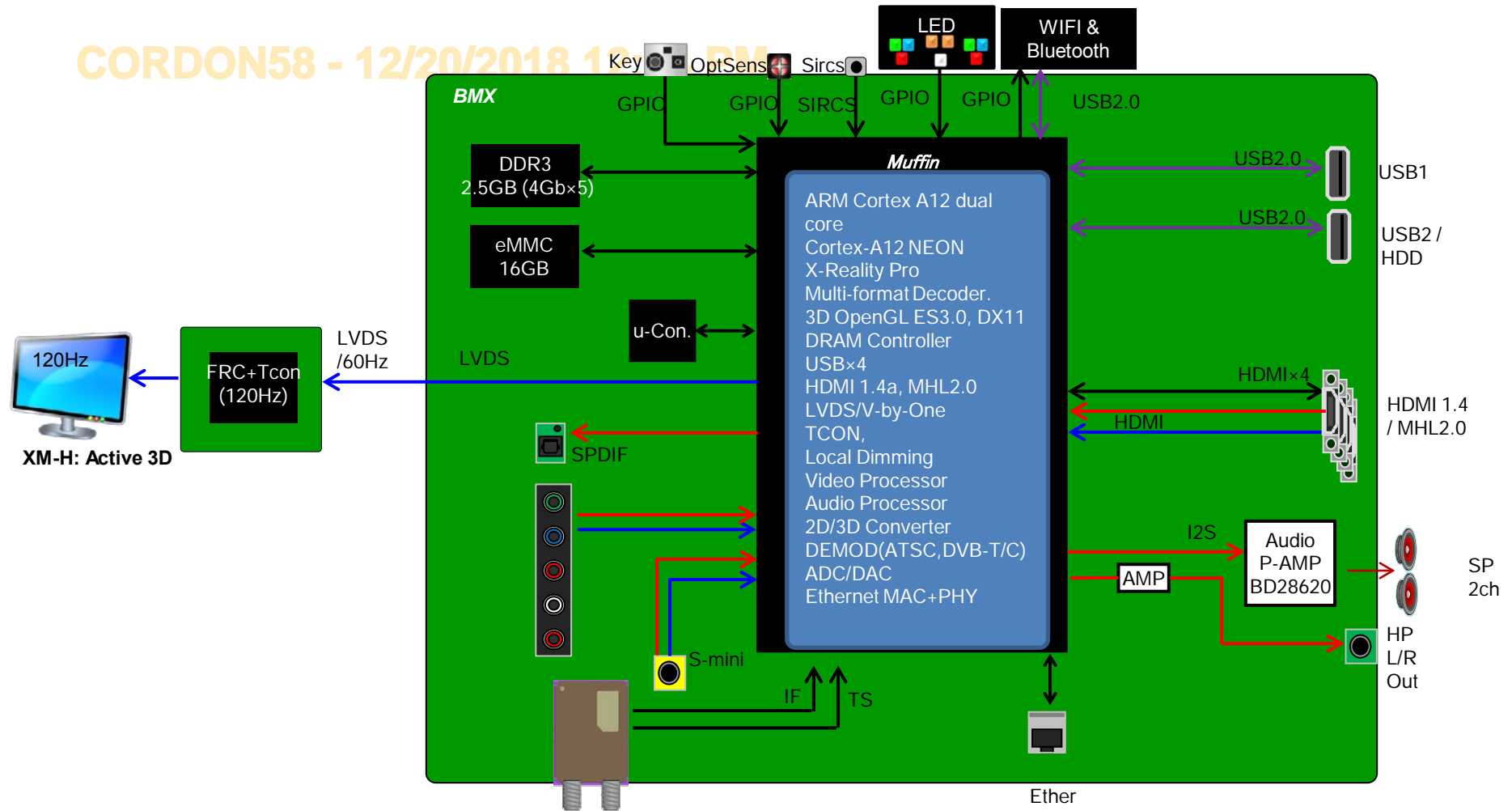

## 5-2. Block Diagram

### 5-2-3. XM-H model (PA,CH)

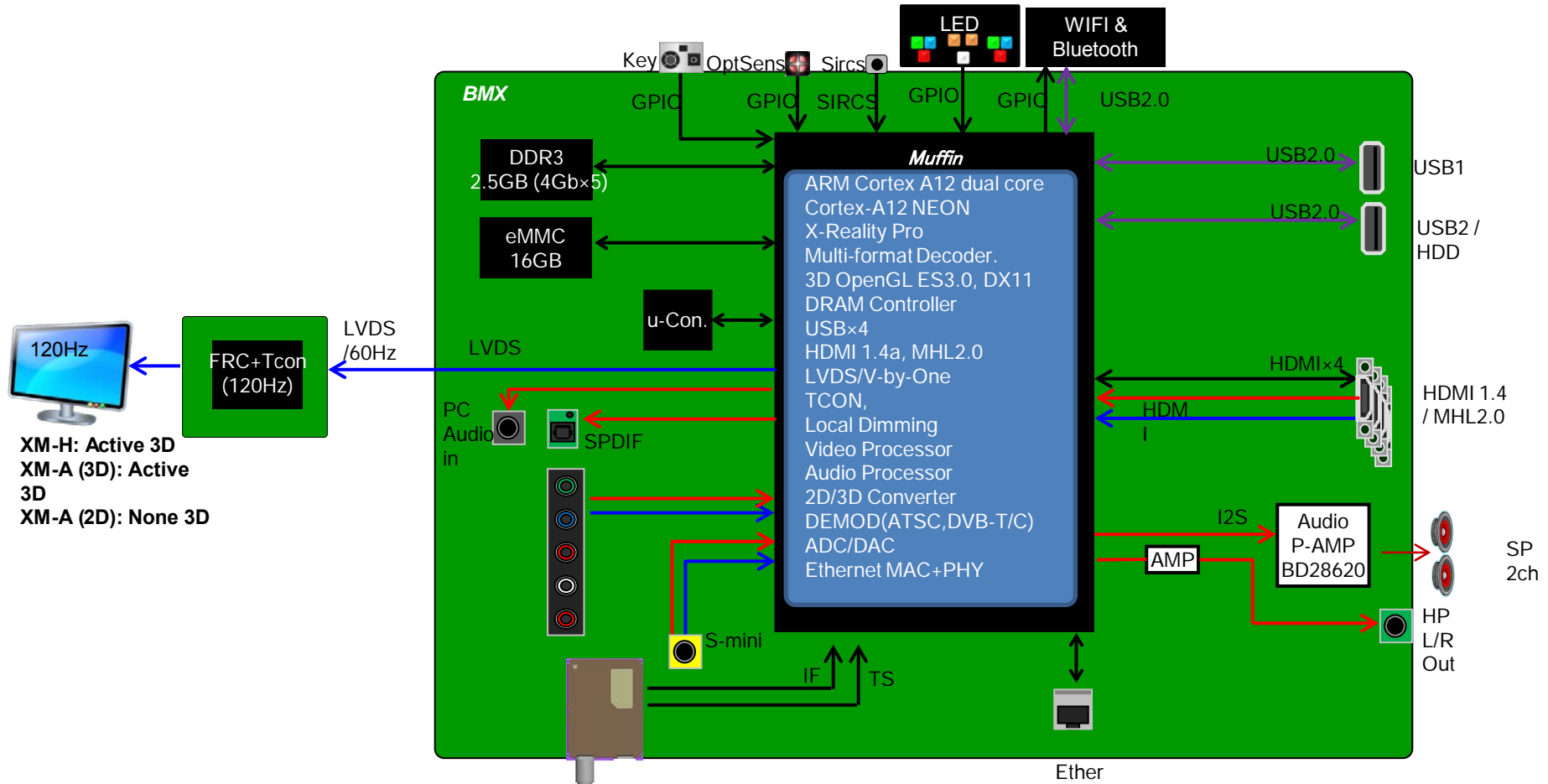



## 5-2. Block Diagram

### 5-2-4. XM-H model (HK,TW)

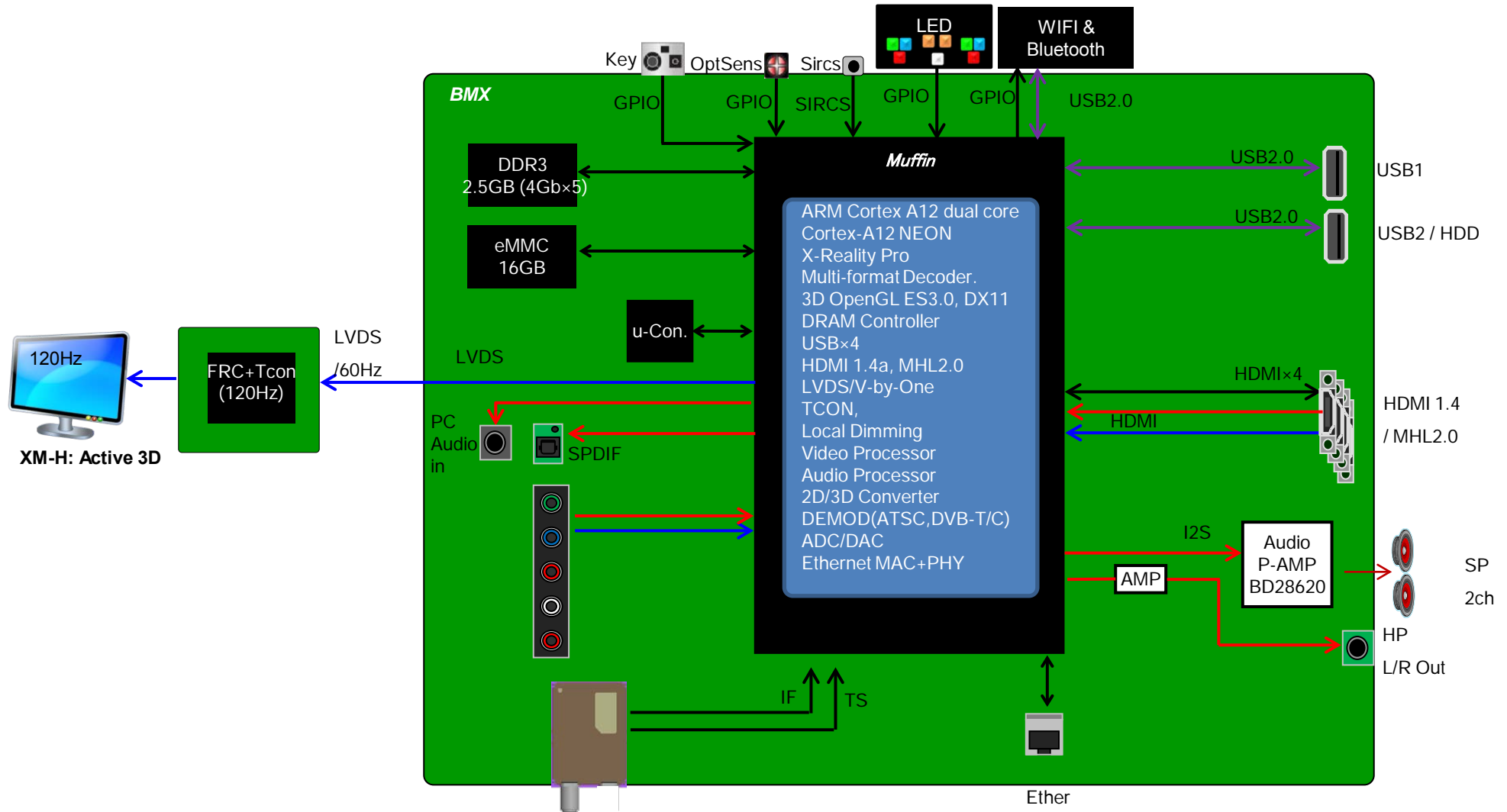

**5-2. Block Diagram**  
**5-2-5 XM-H model (JP)**

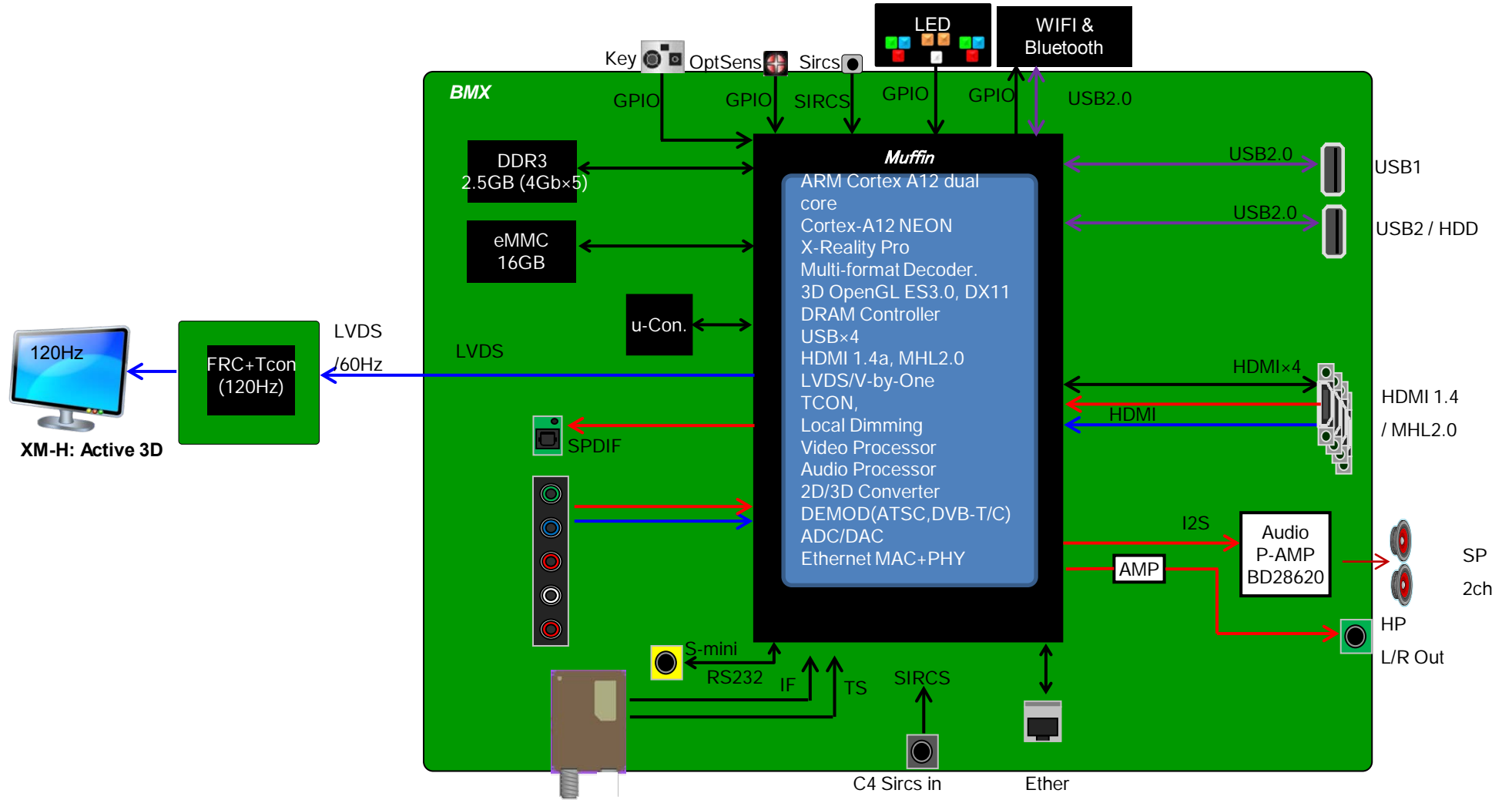

5-2. Block Diagram

5-2-6 XM-H model (UC)

CARDON58 - 12/20/2

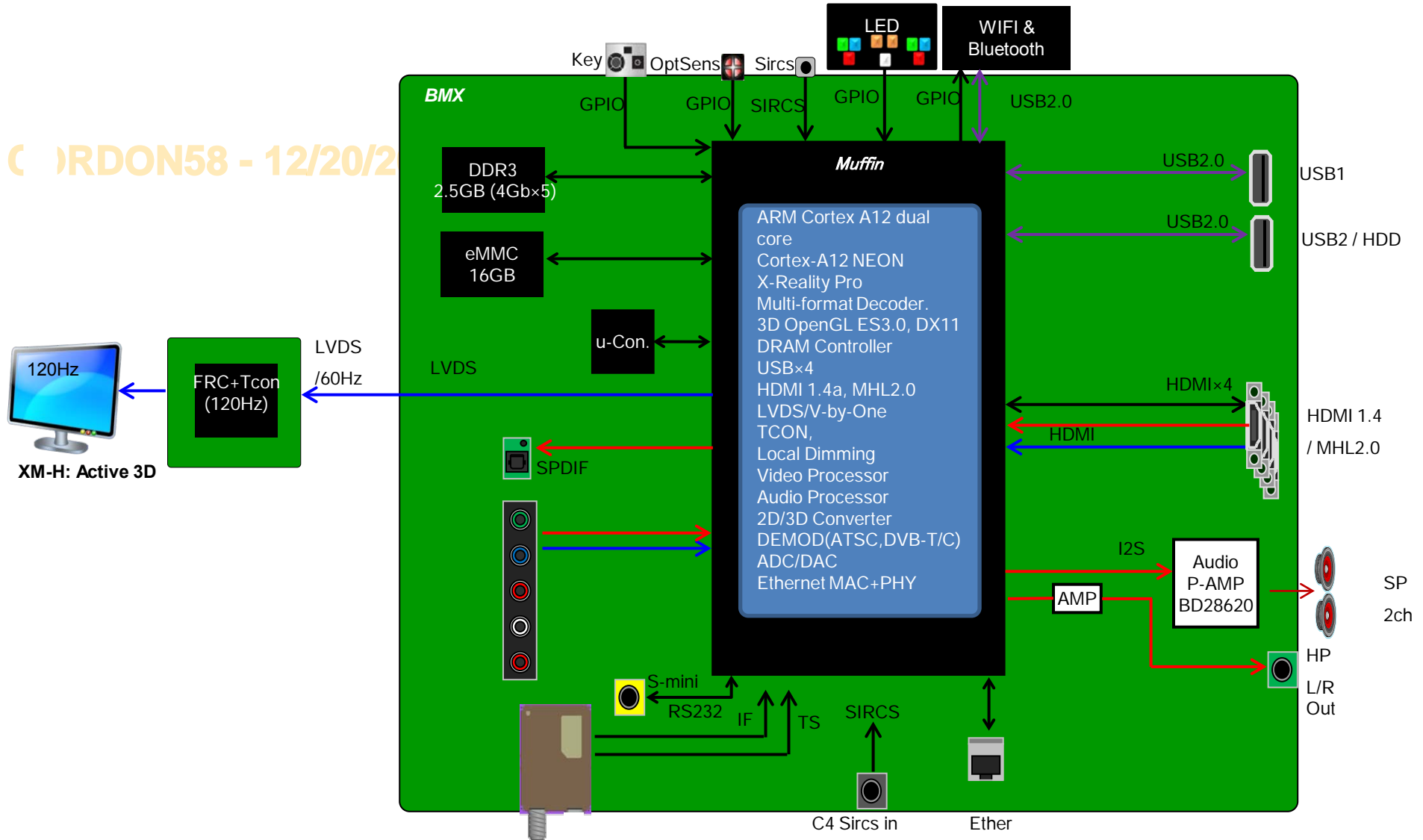

### 5-3. Connector Diagram

#### 5-3-1. 65"

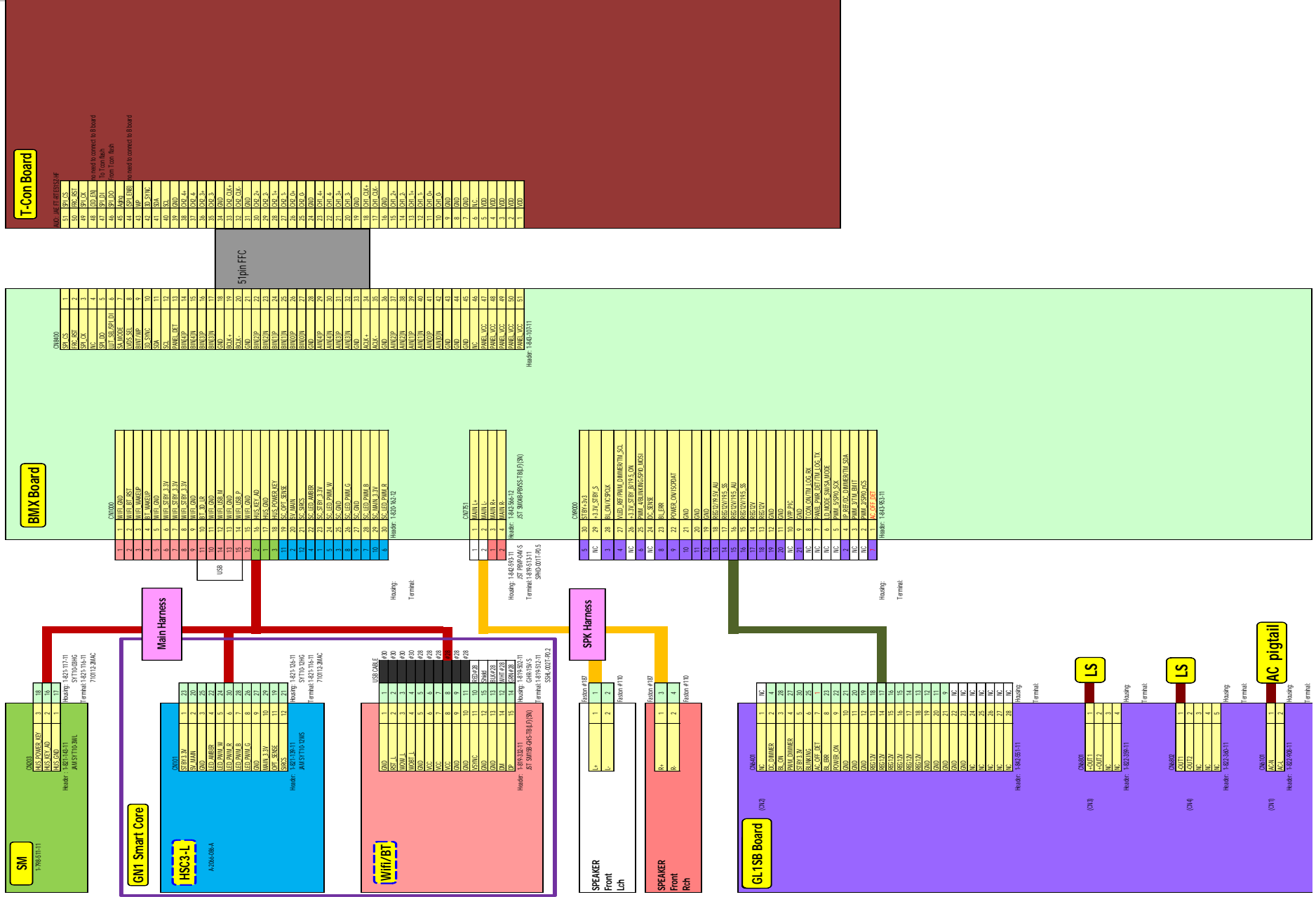



### 5-3. Connector Diagram 5-3-2. 75"

