

AV3 AV32

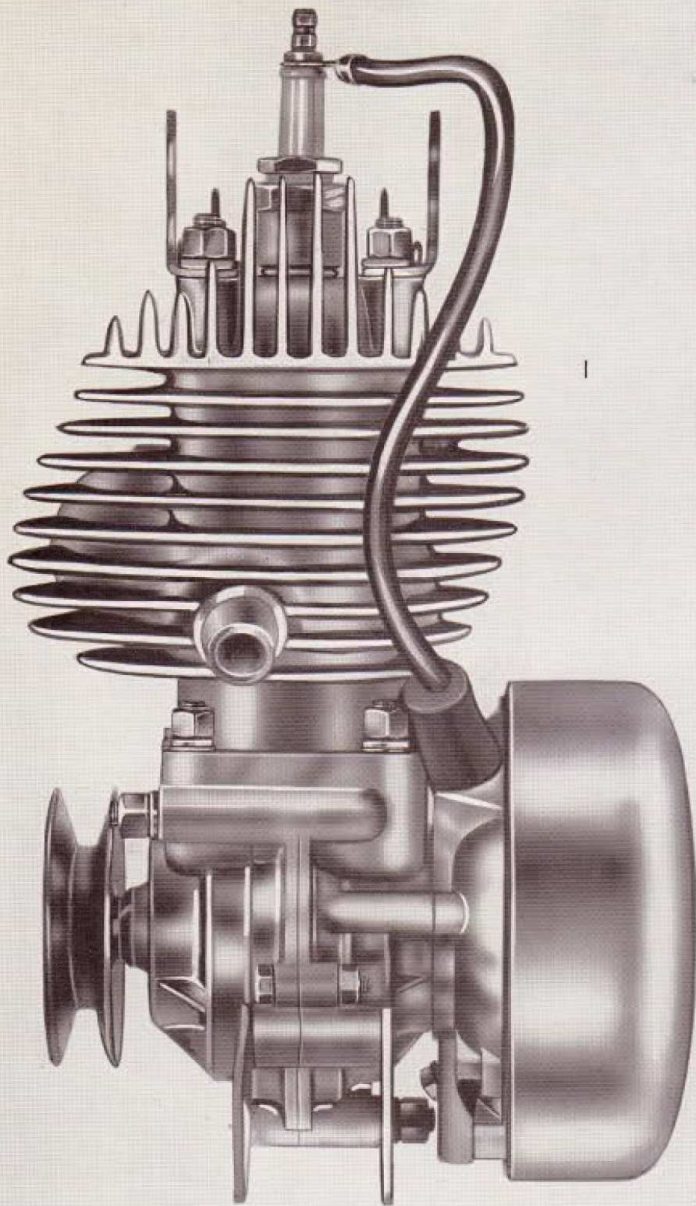

1

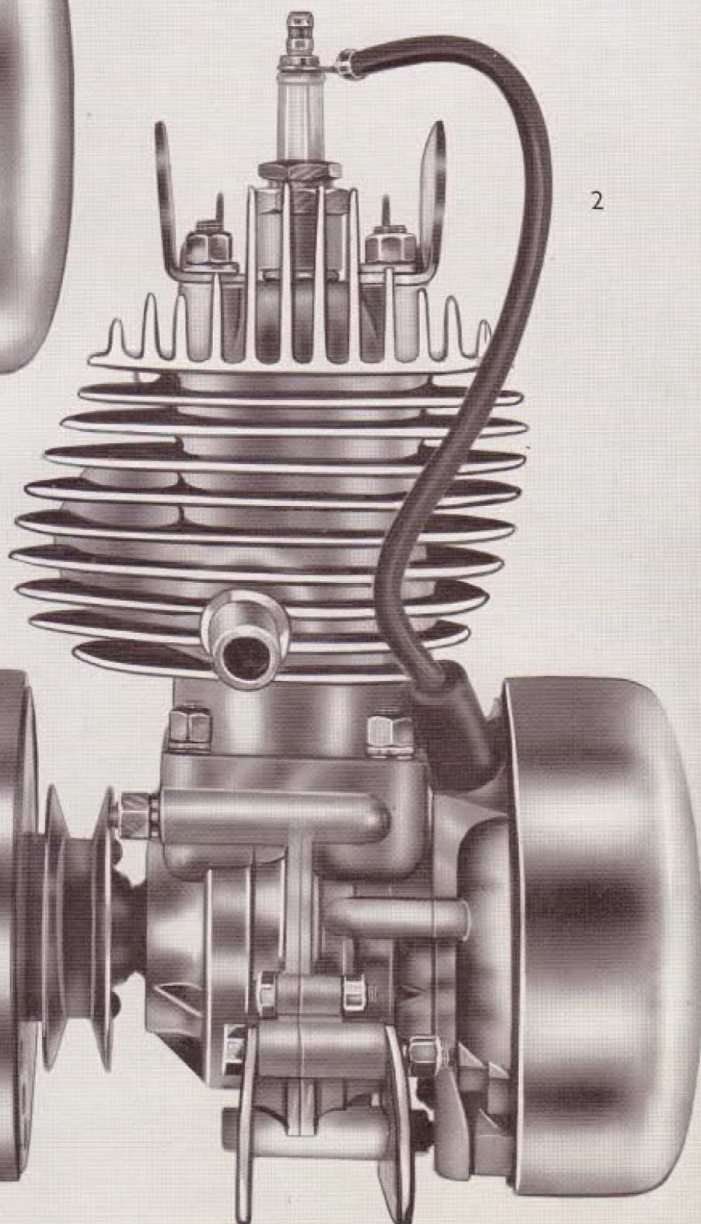

2

AV31



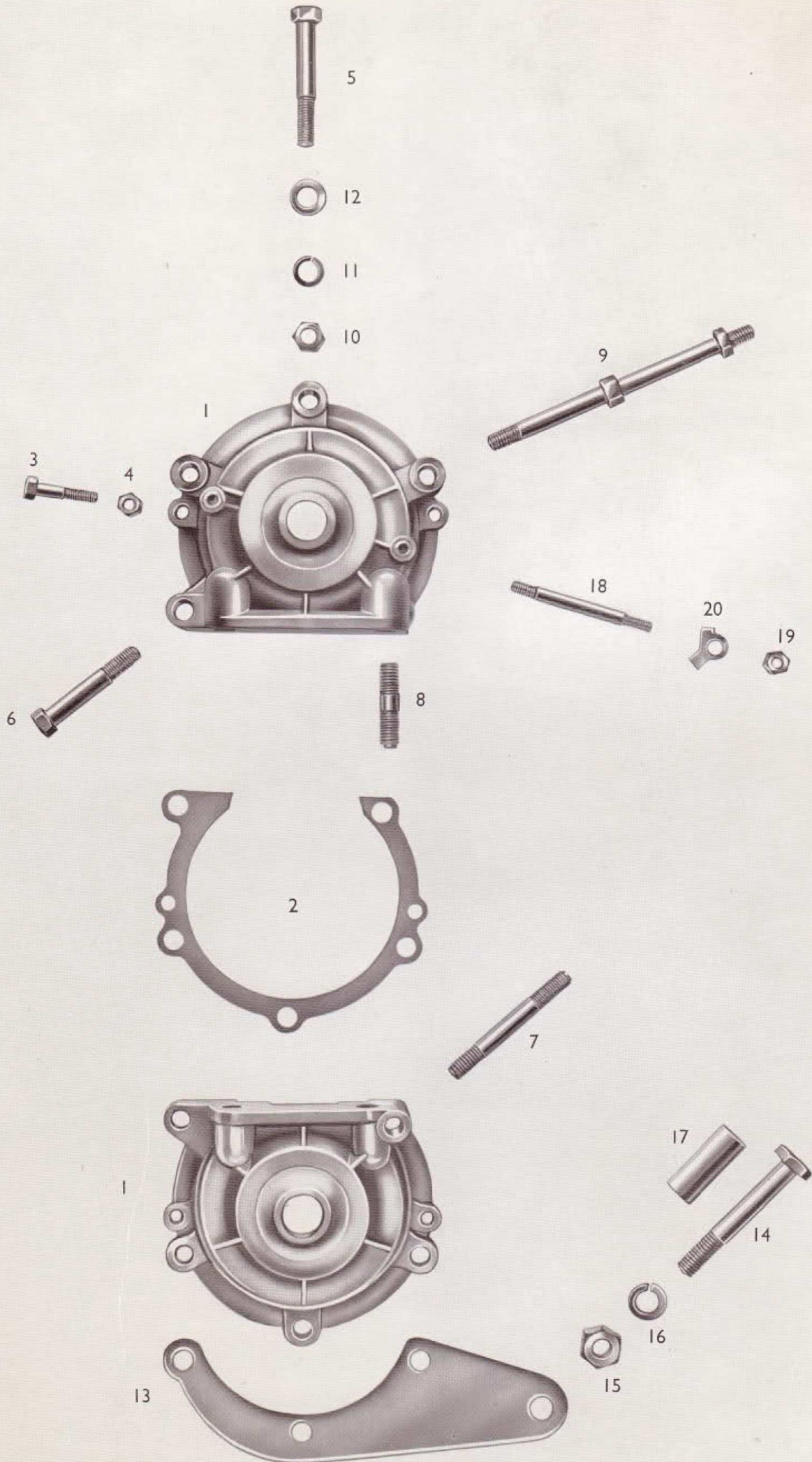



AV3 AV32

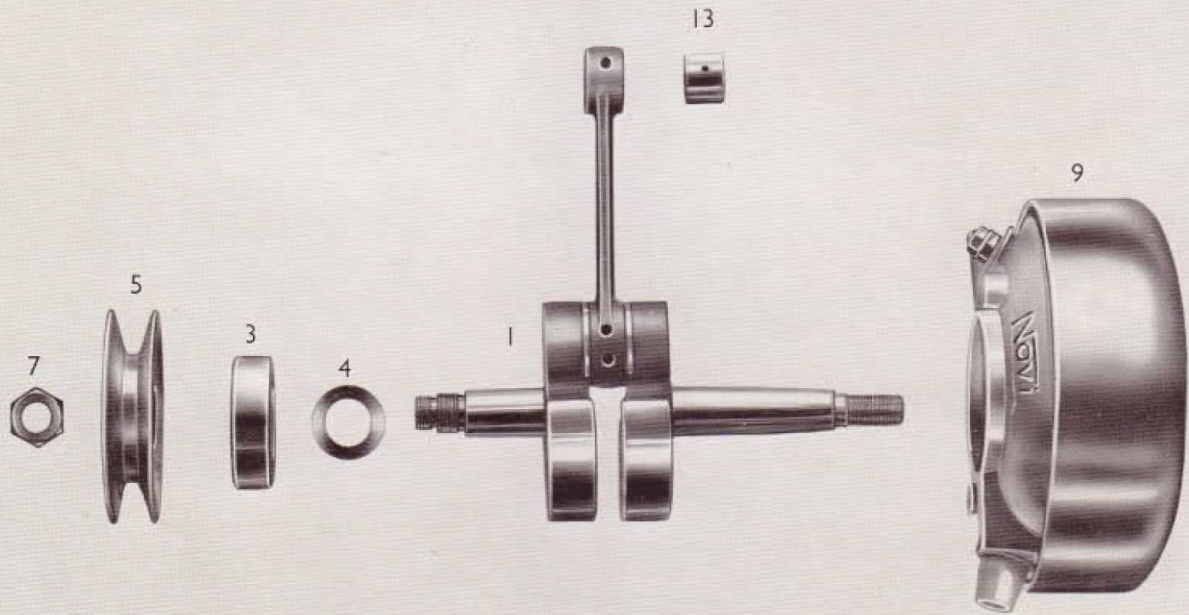
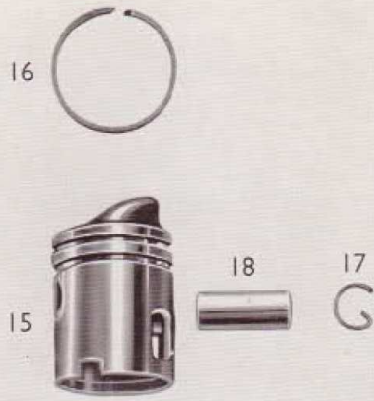

AV31

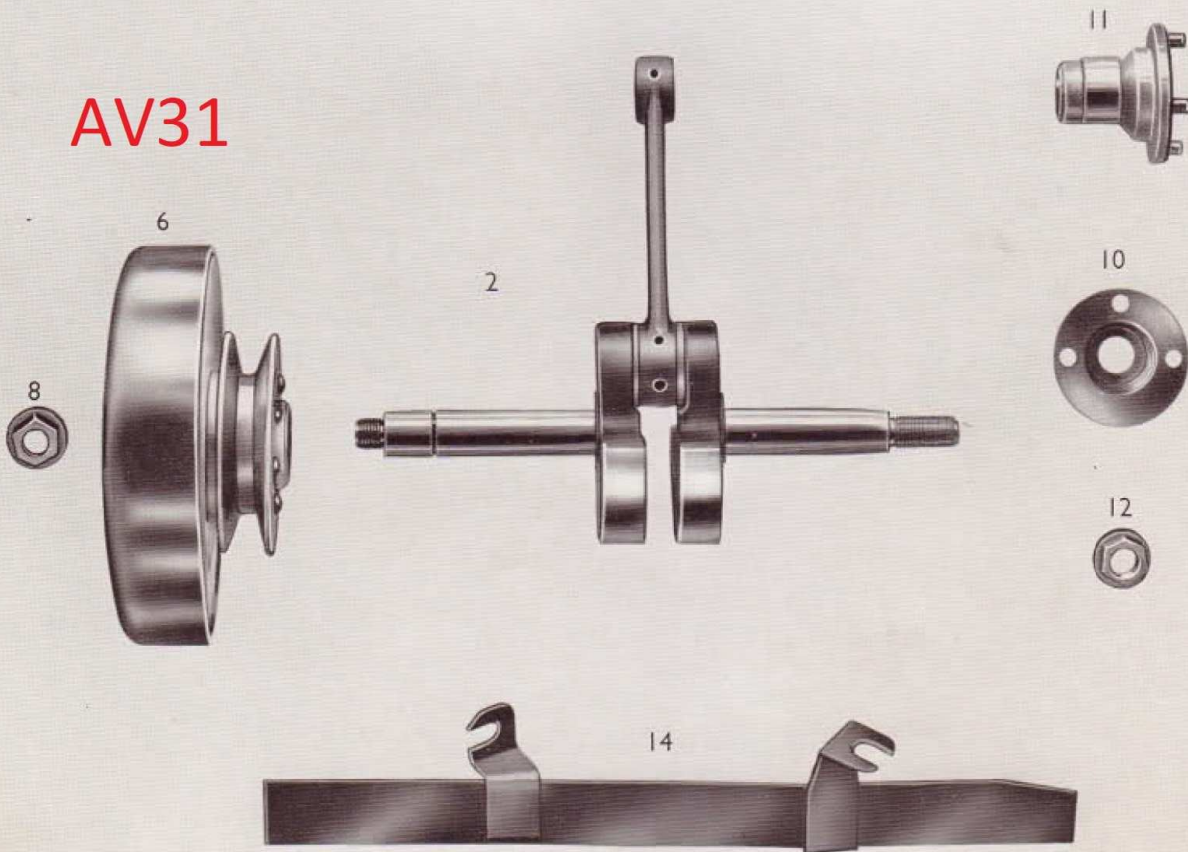



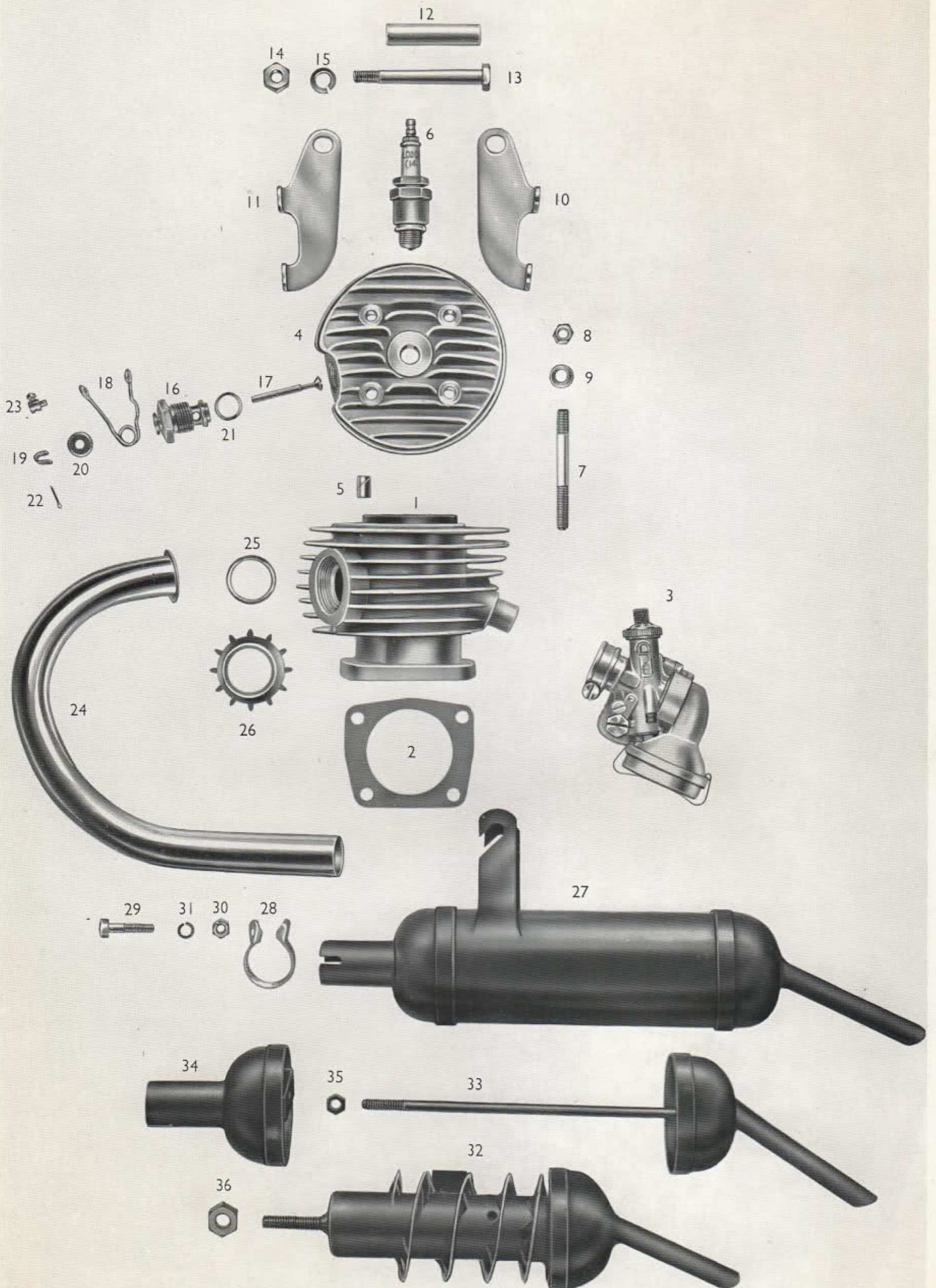



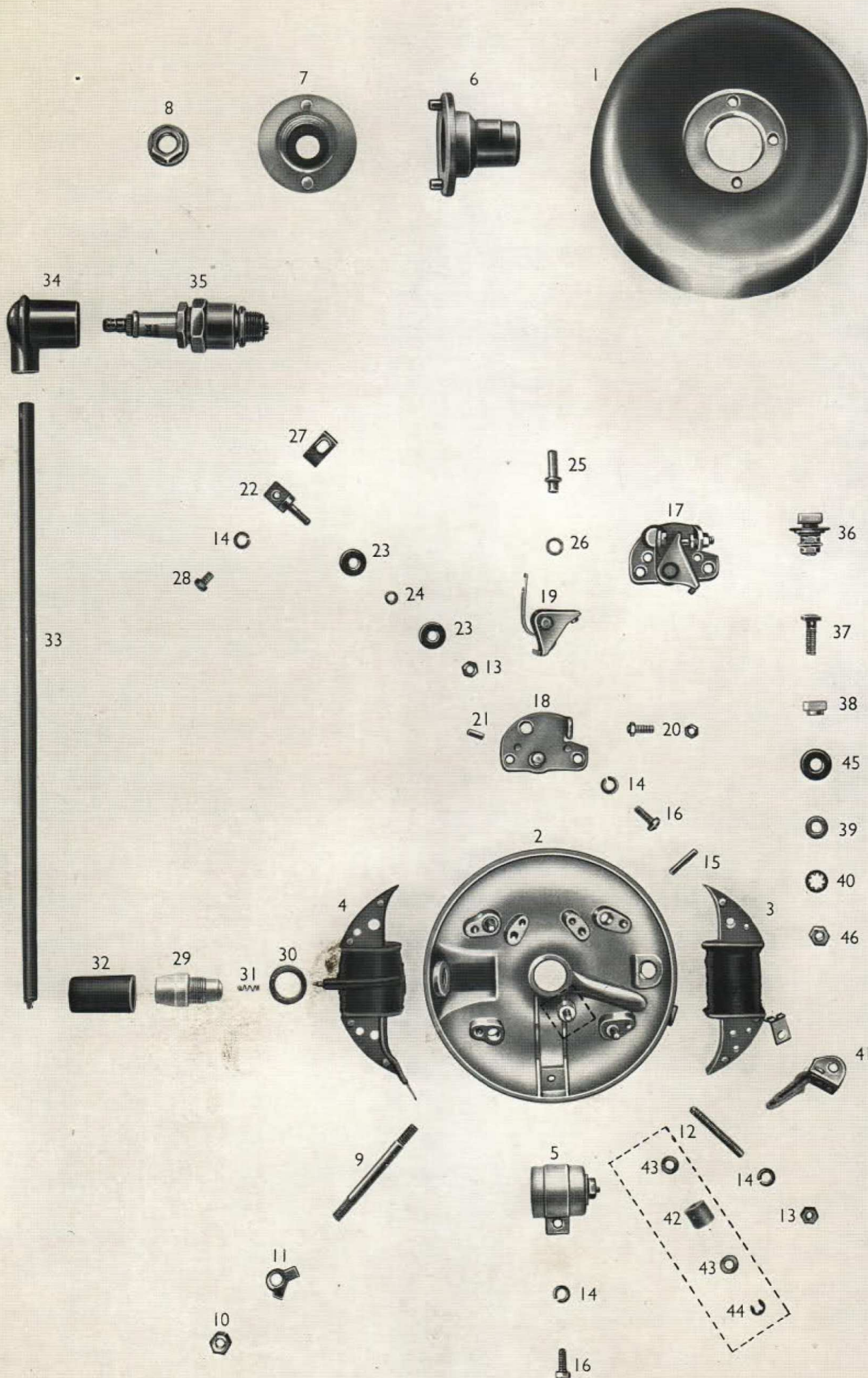



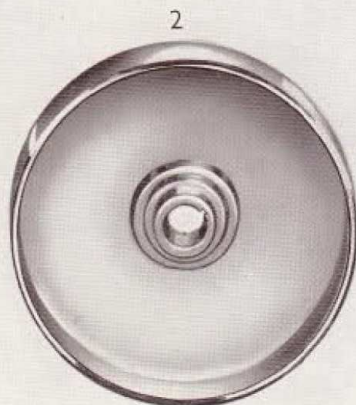
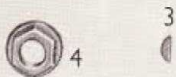
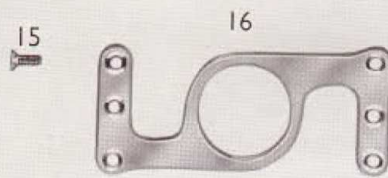
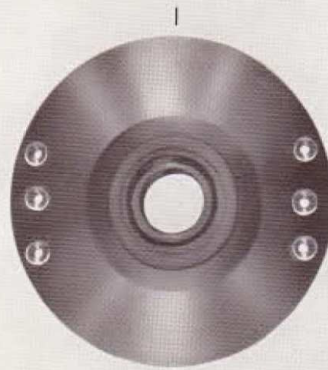
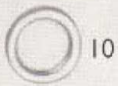
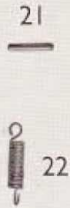
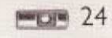
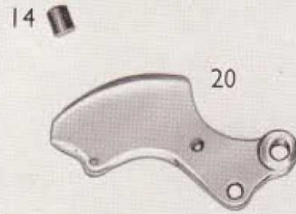
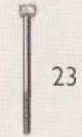



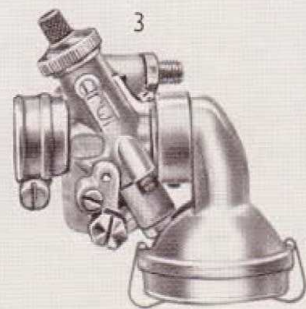
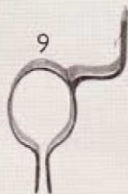
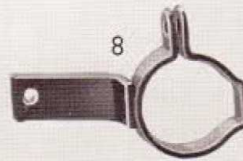
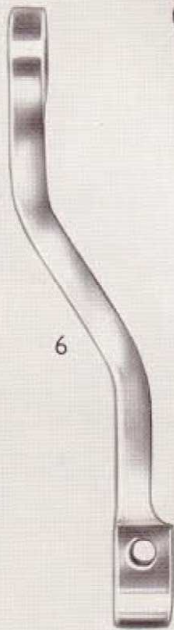
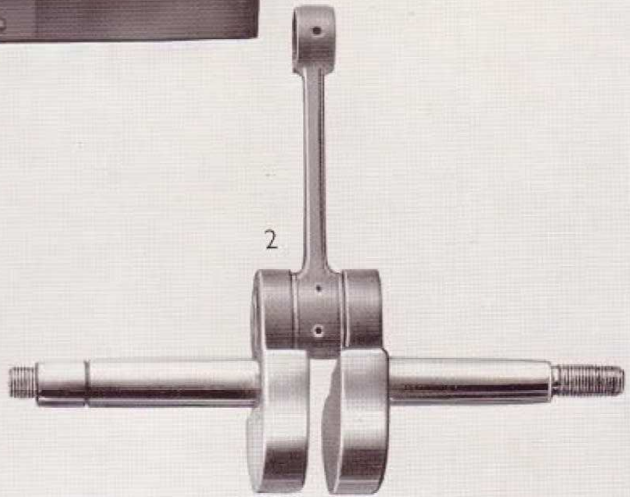
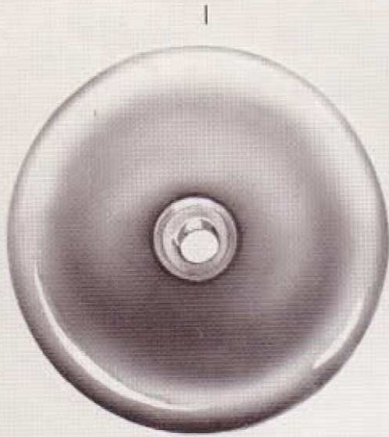

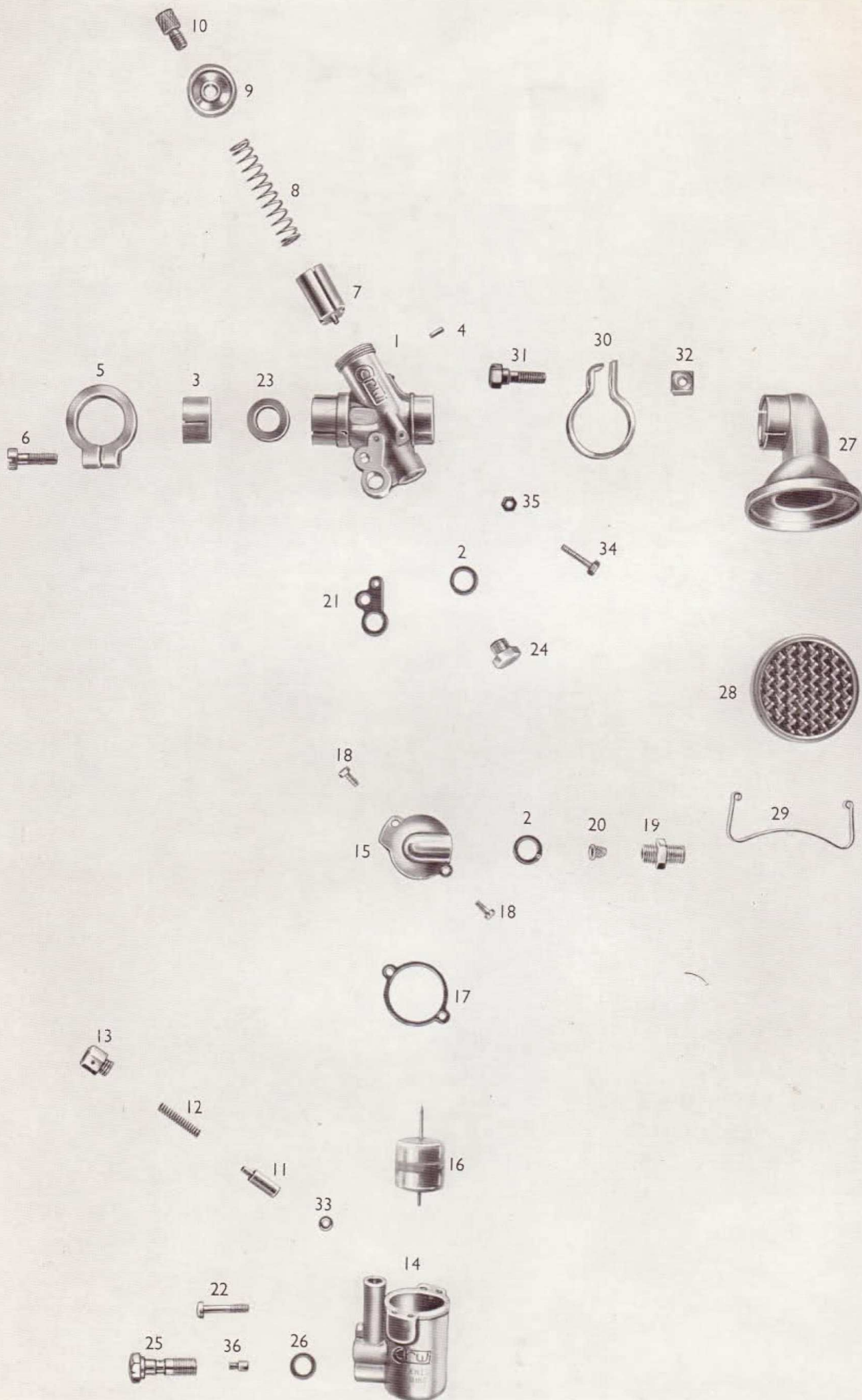



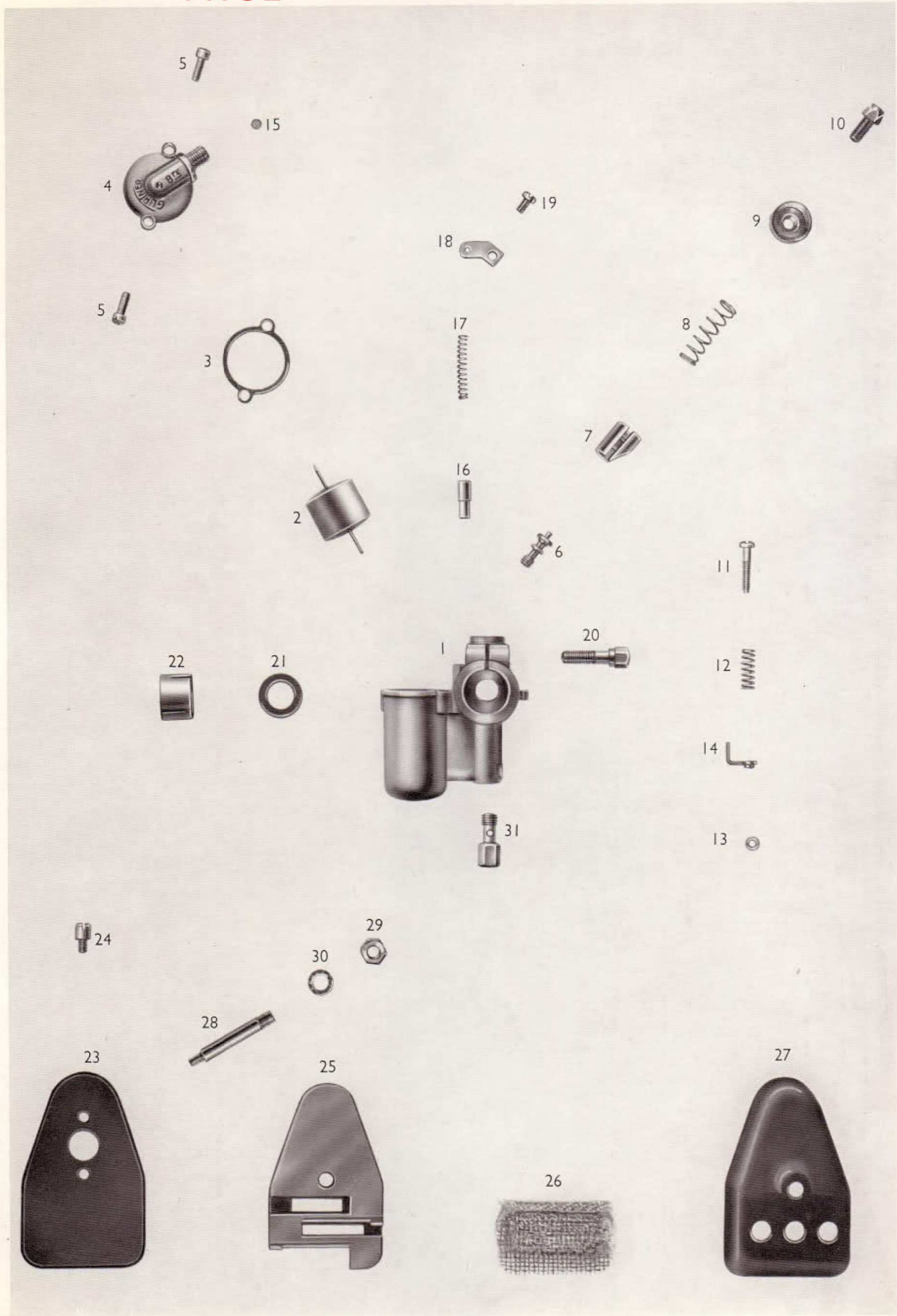



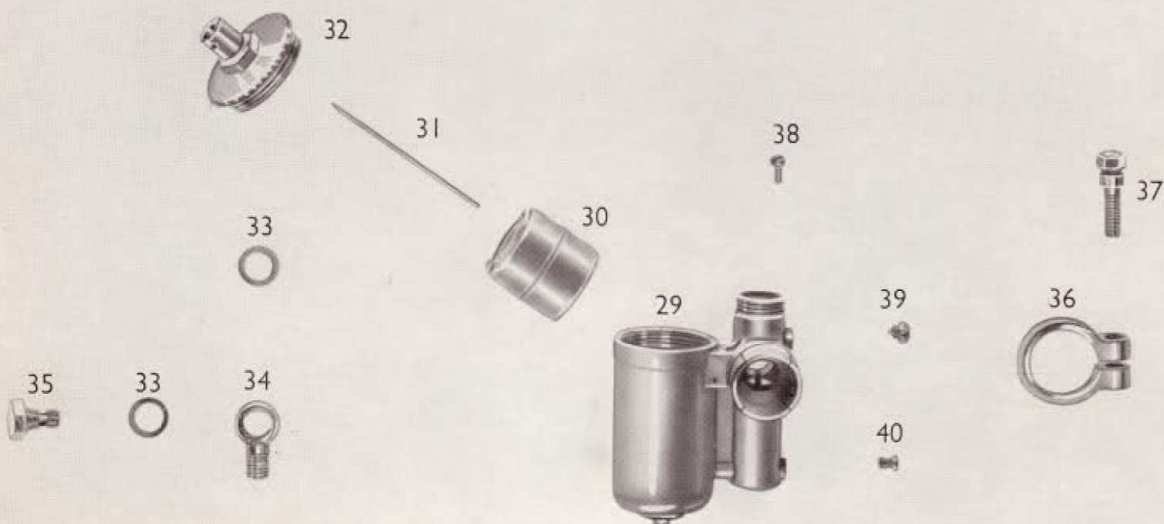
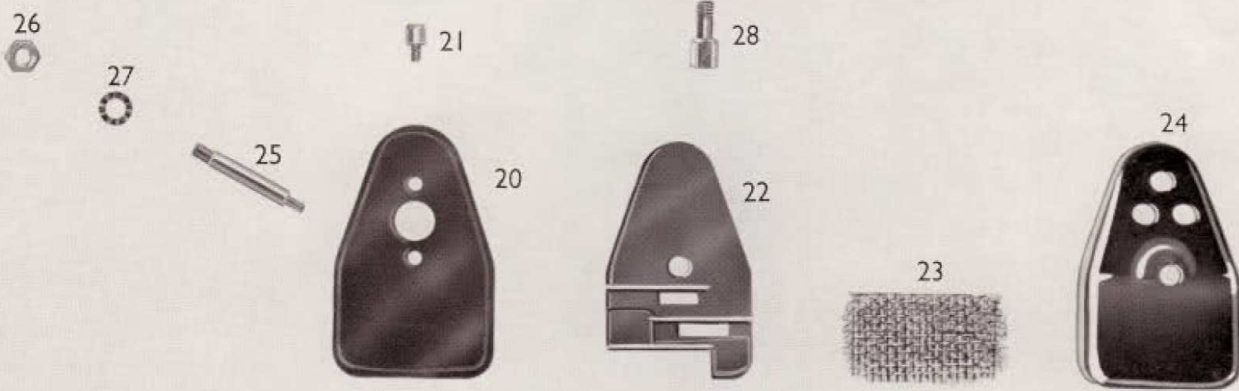
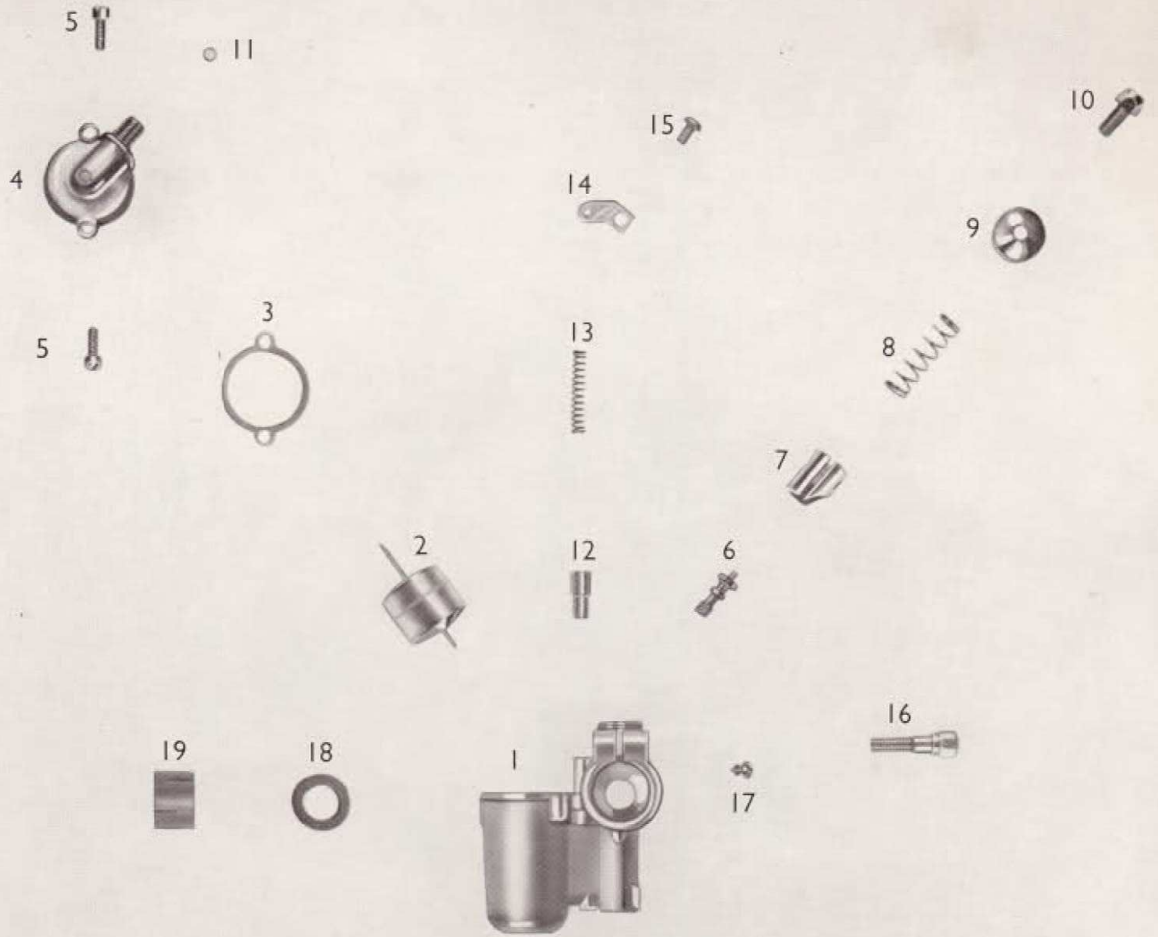



AV3 AV31

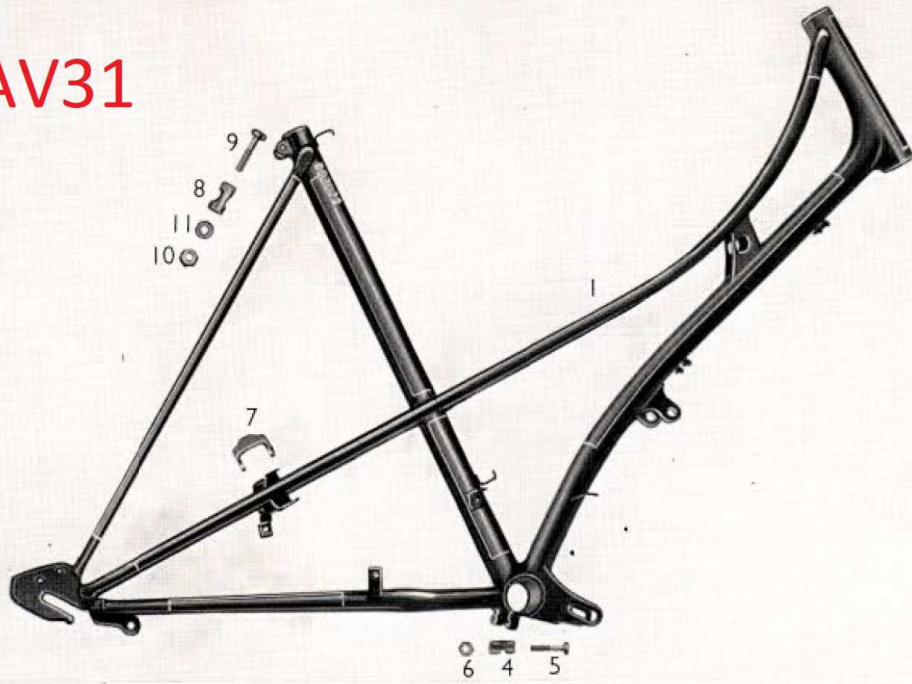

AV32

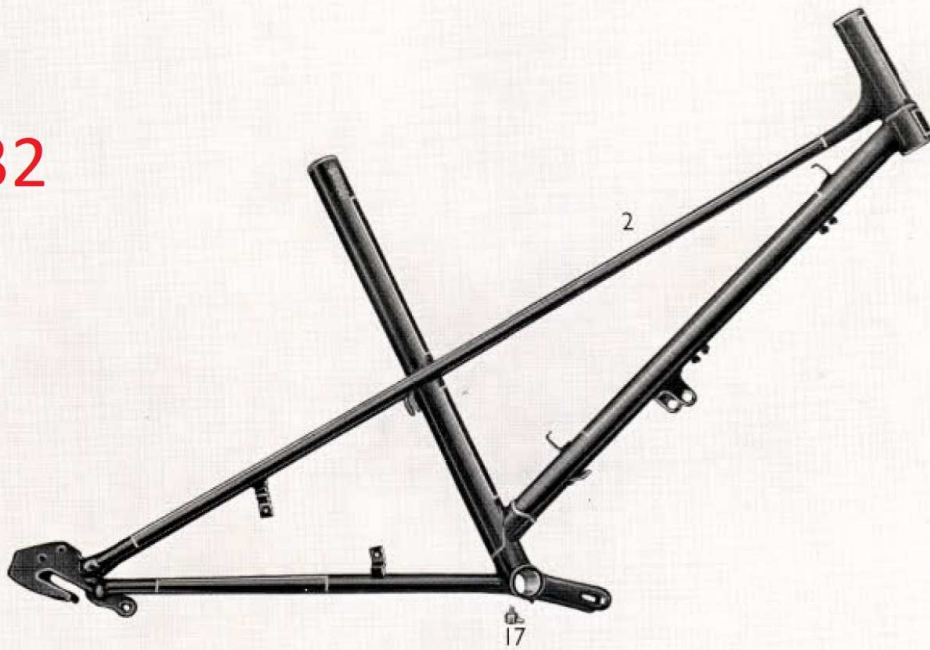

Transporter

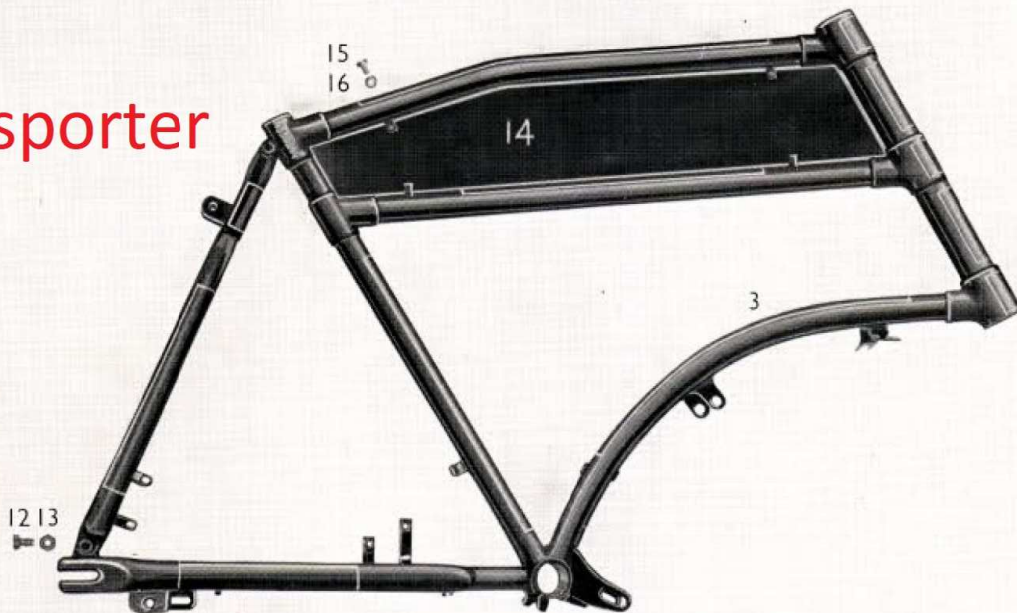



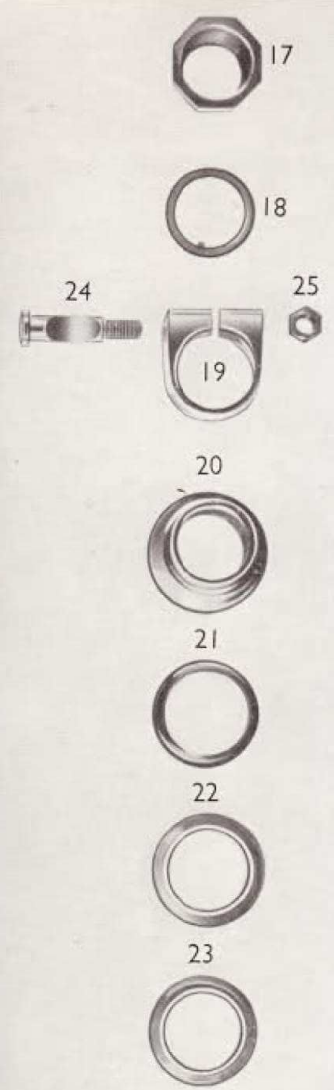
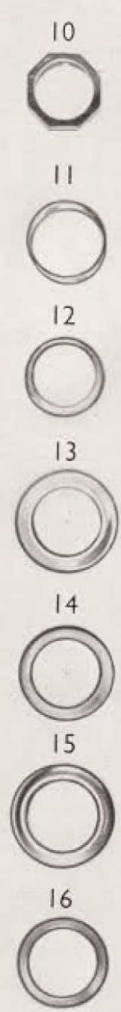
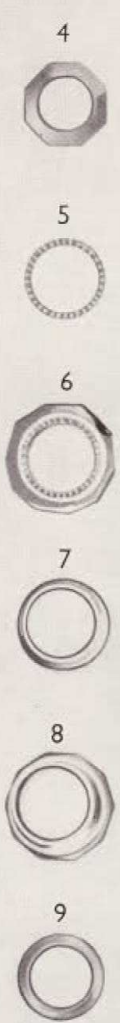

AV3  
AV32

3

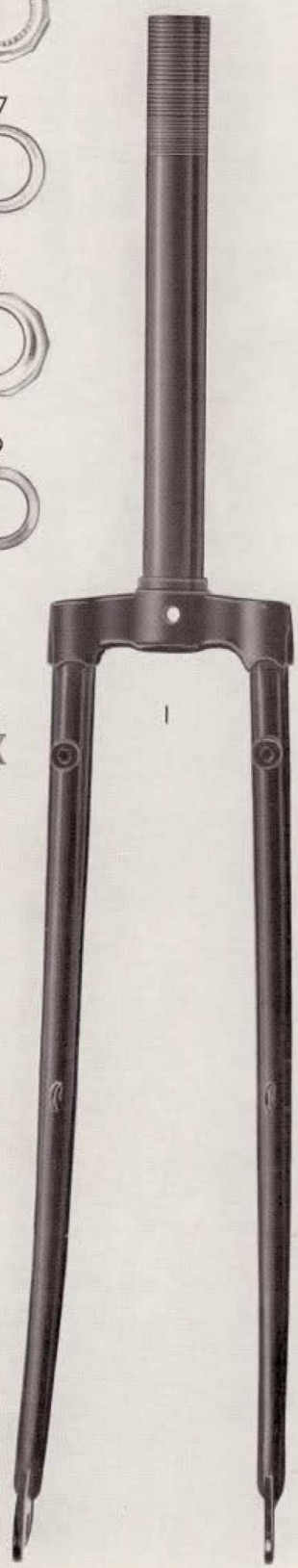

1

2



transporter



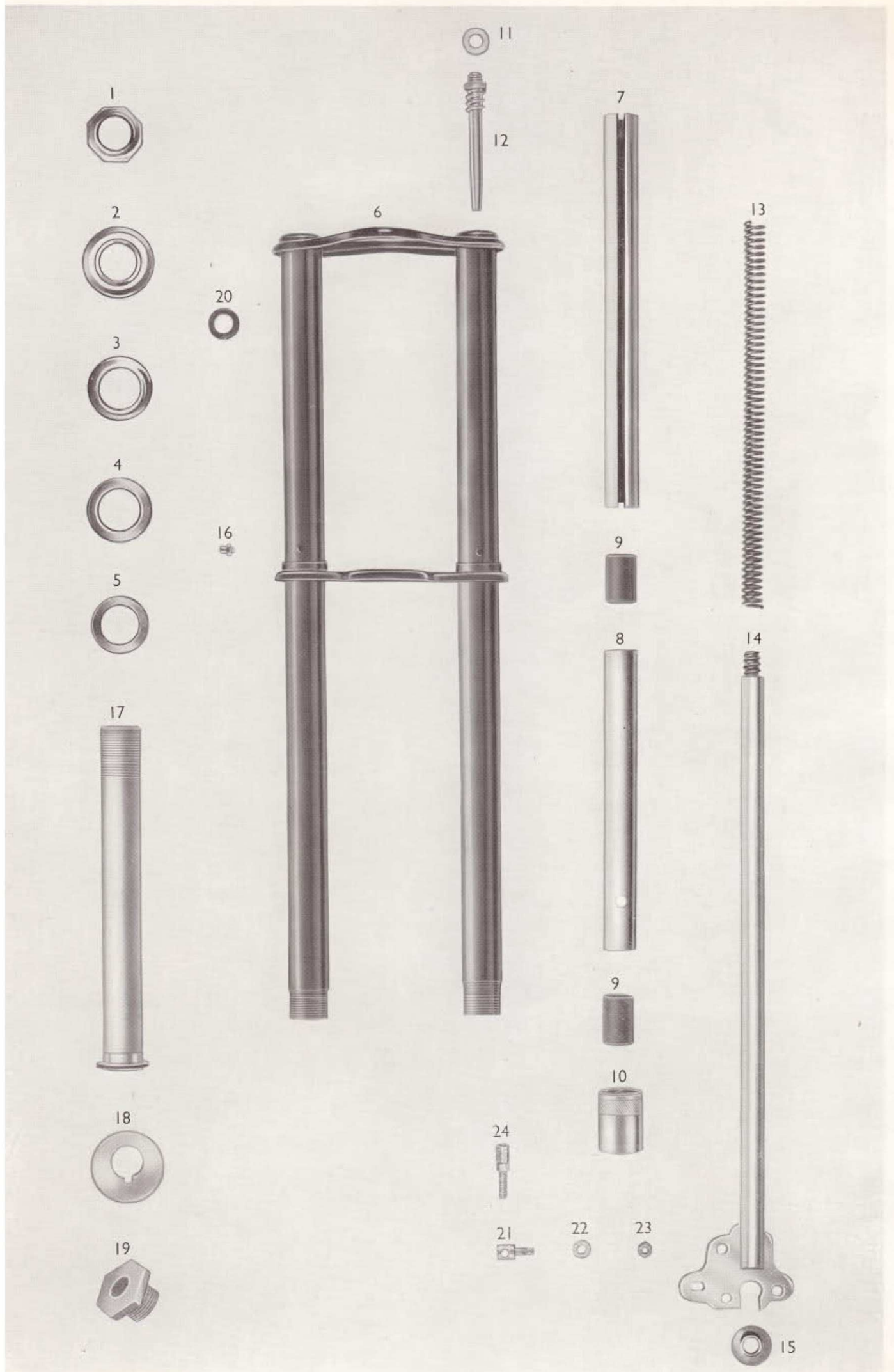



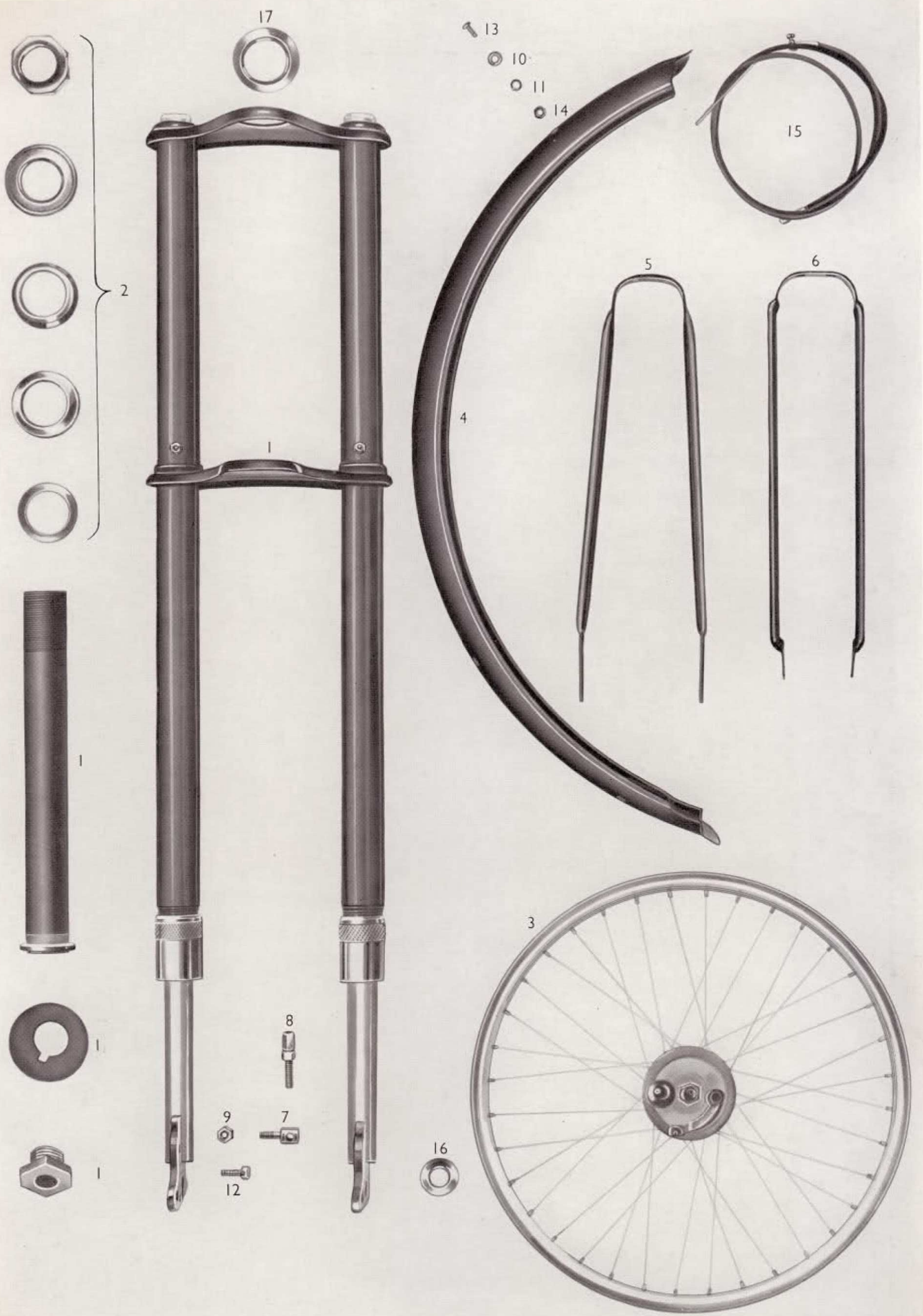

modele 50/53

modele 54

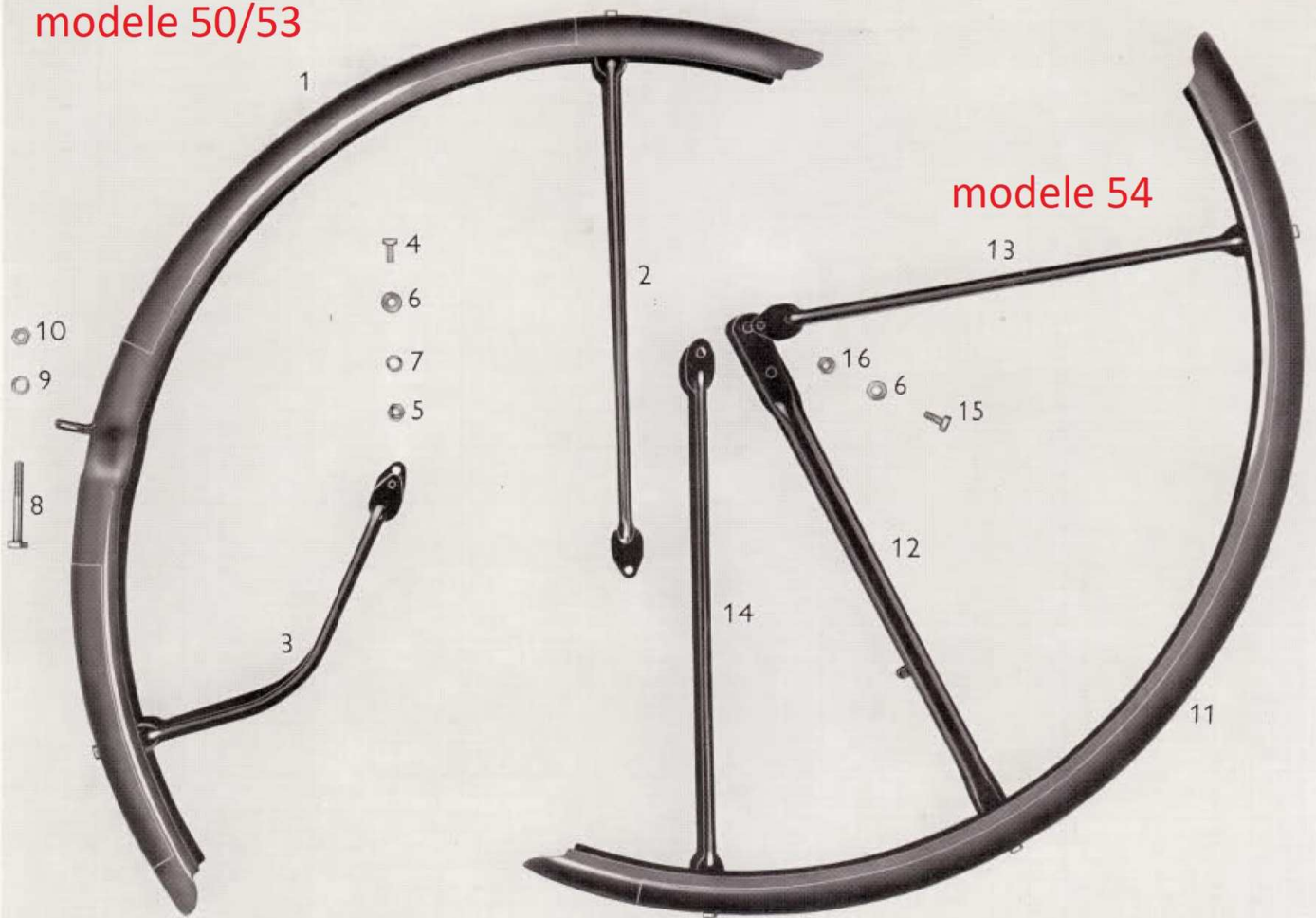

Transporter

AV31

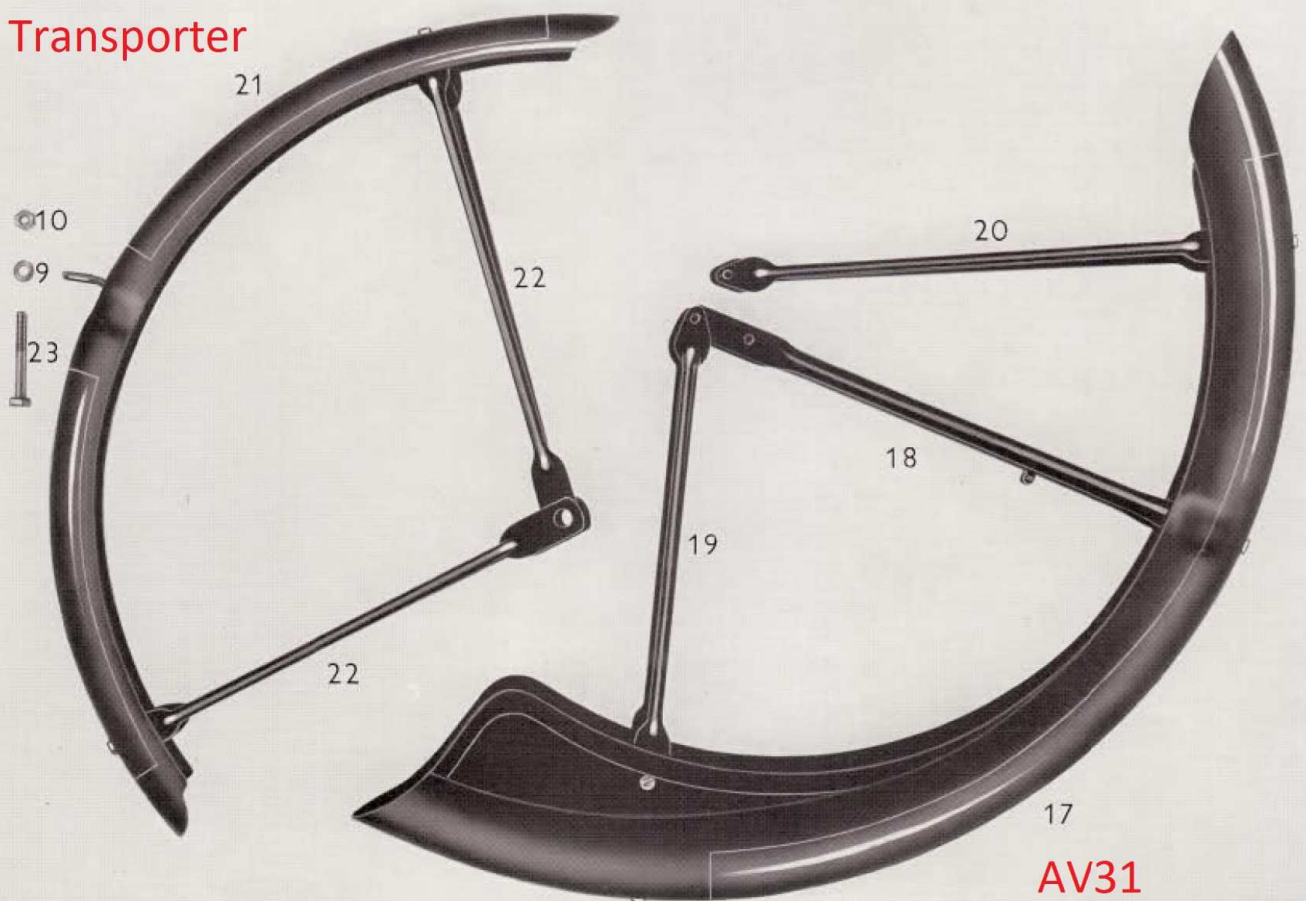



AV3 AV31

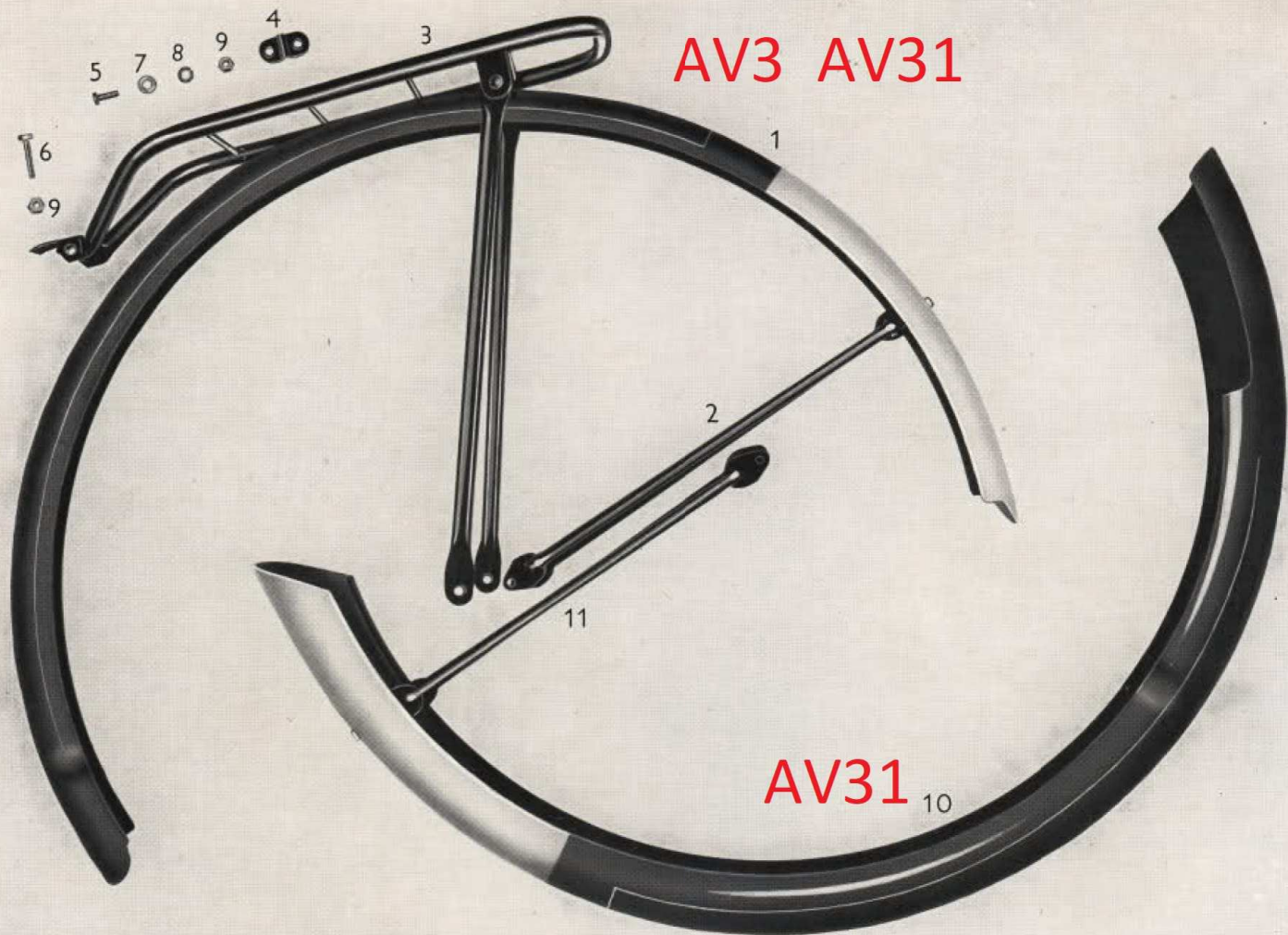

Transporter

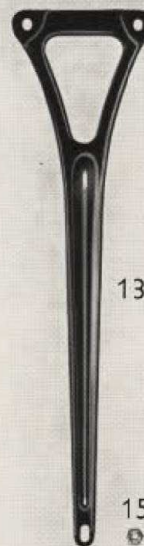
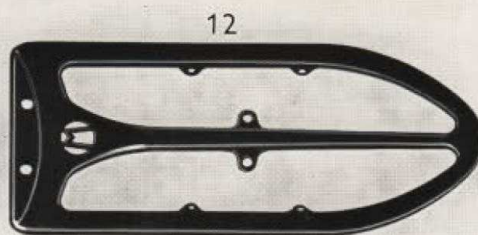

17 16

AV32

13

15 14



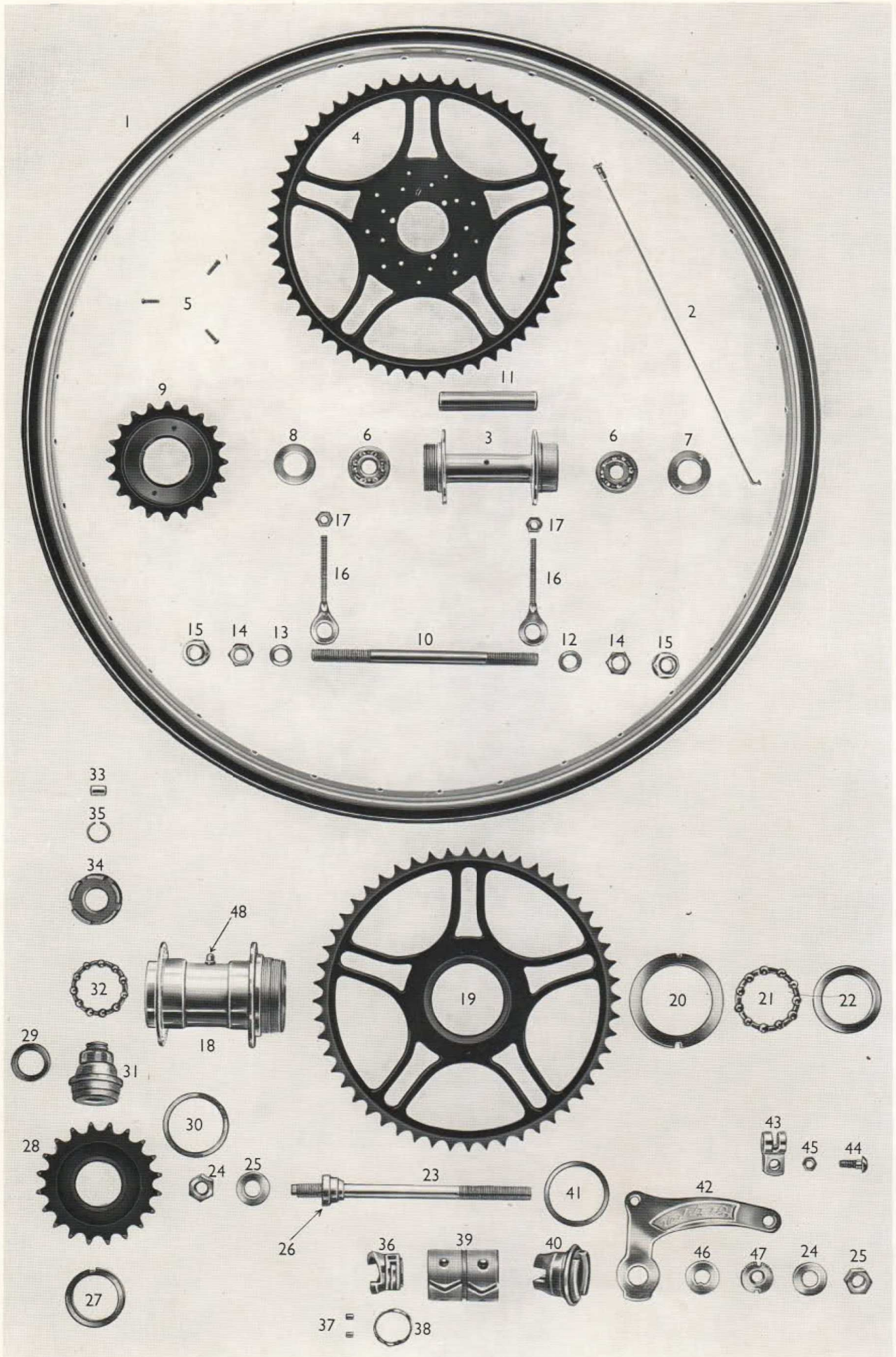



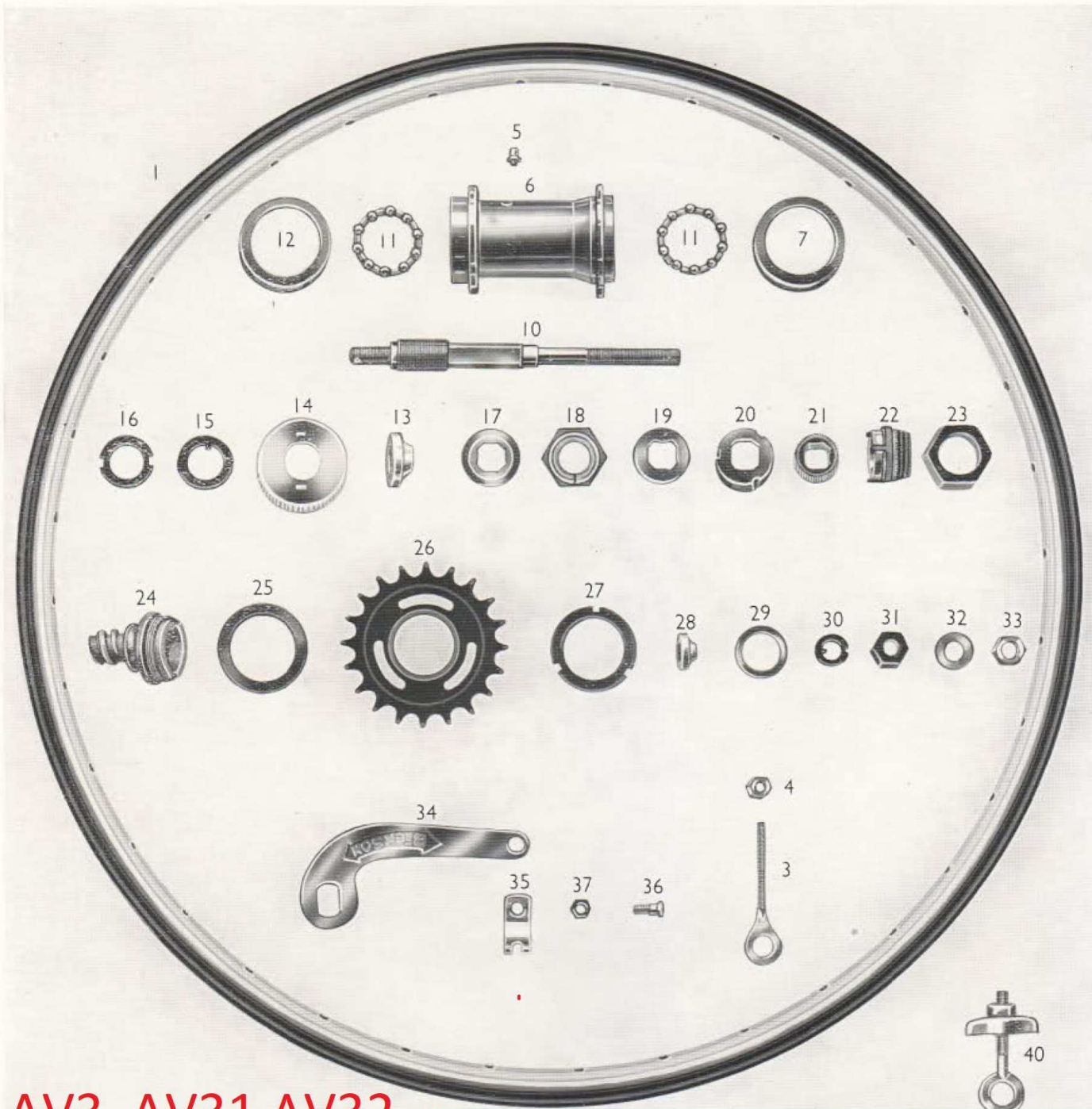

AV3 AV31 AV32

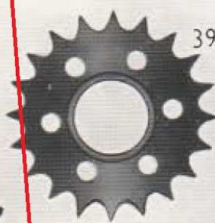
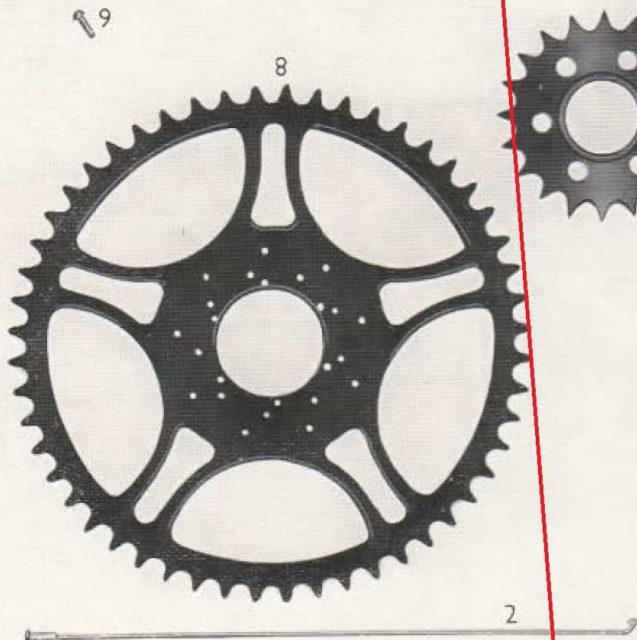

Transporter



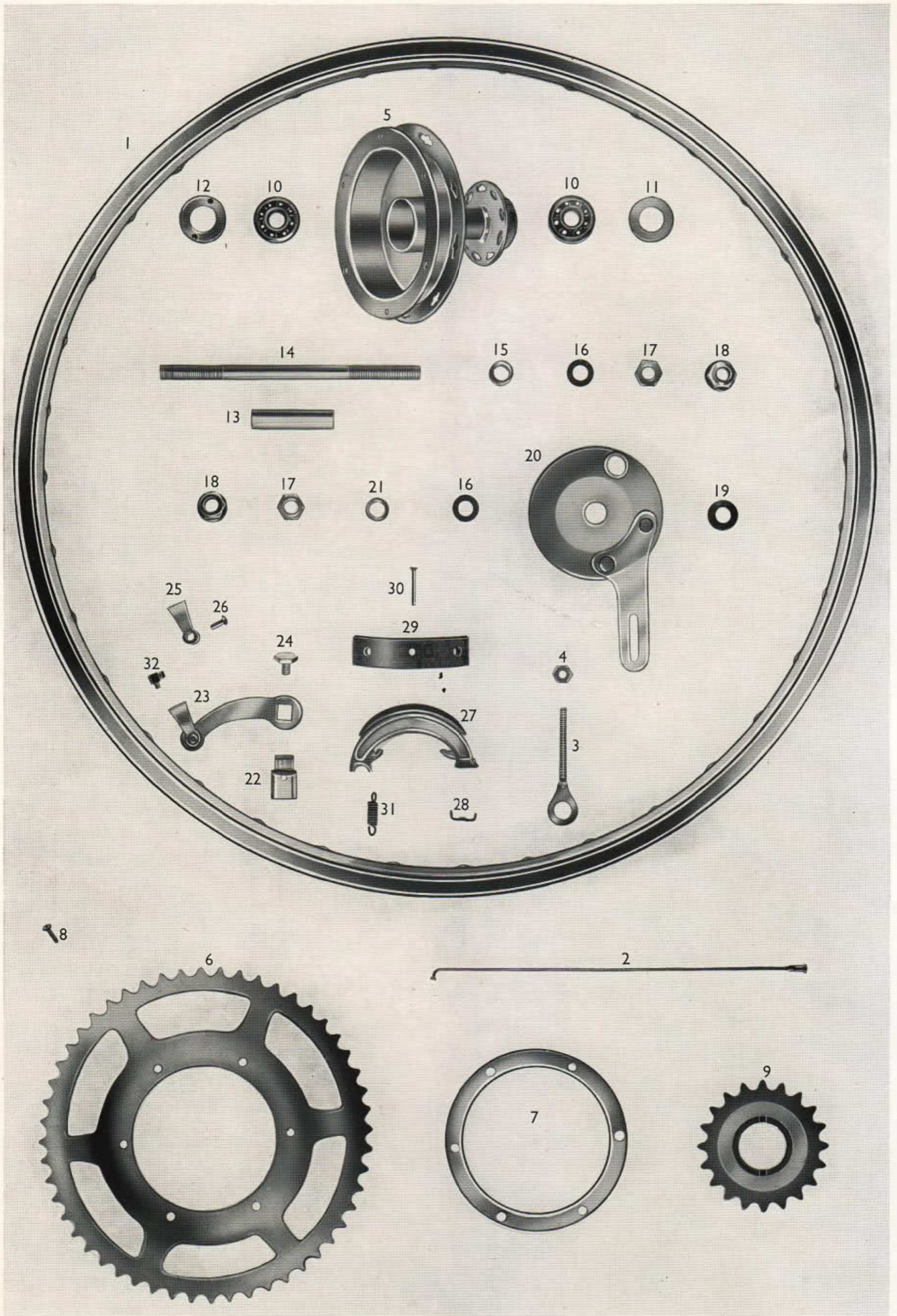



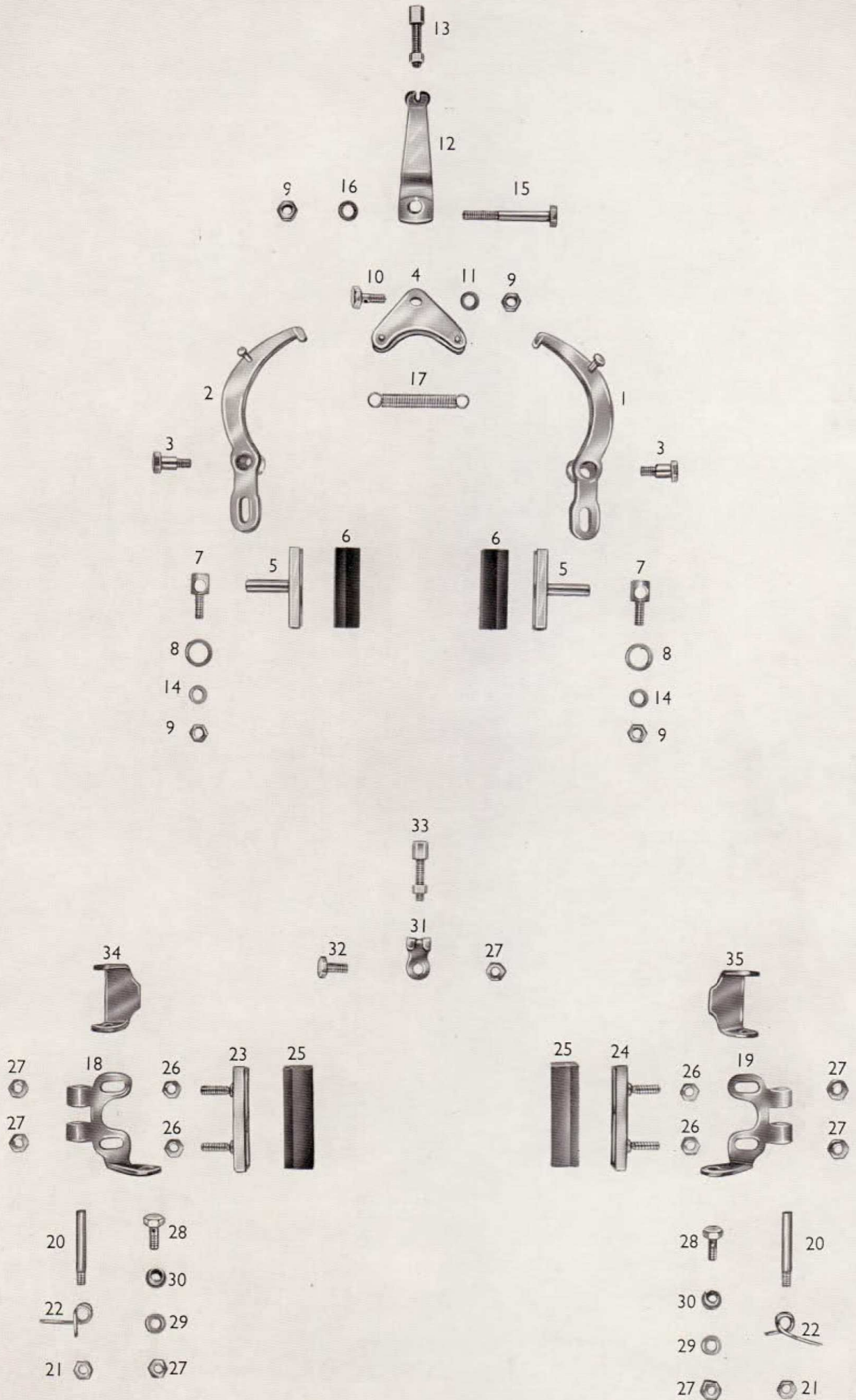

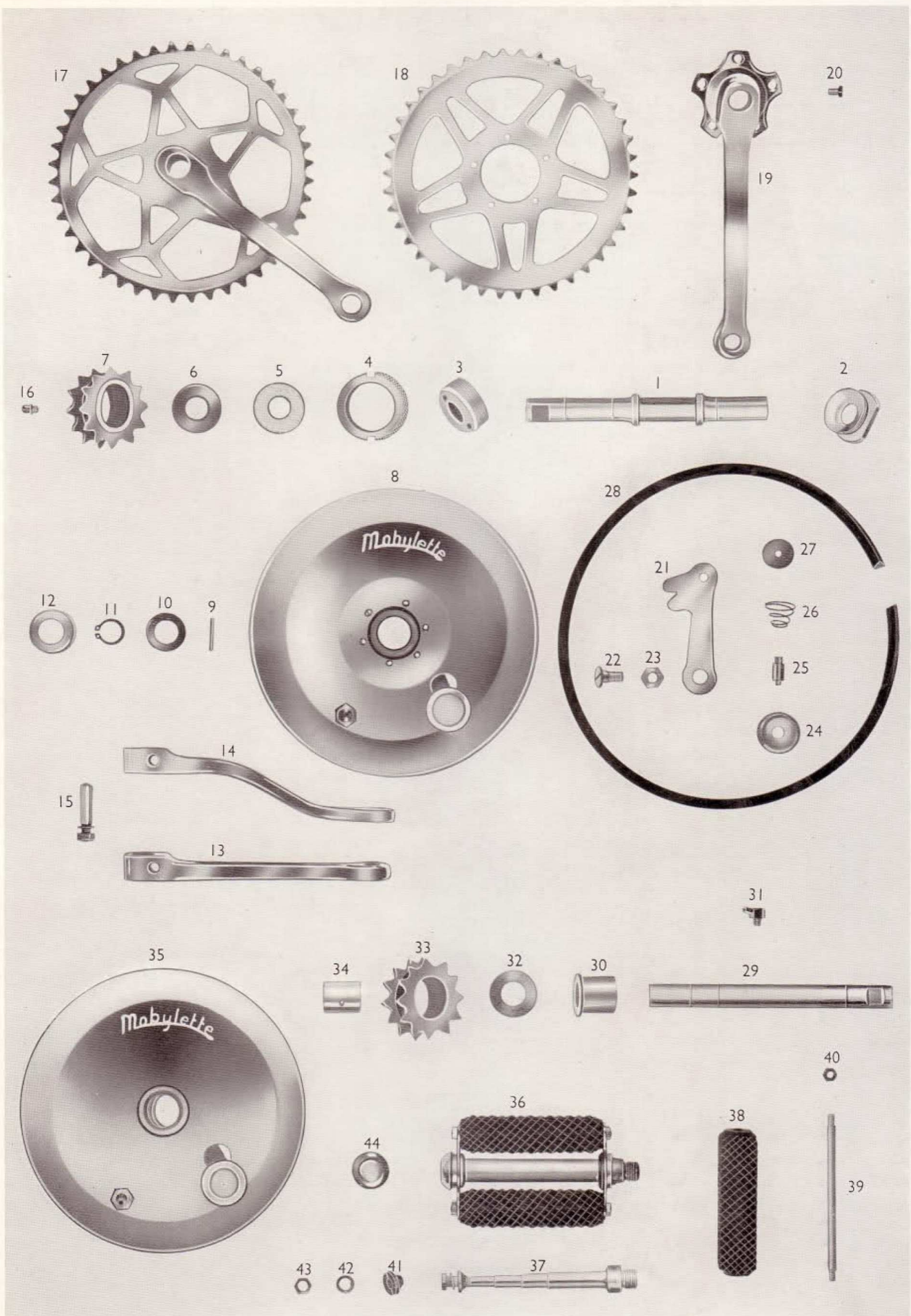



GROEP 27

KETTINGSCHEMEN - V-SNAARBESCHERMER - KETTINGEN - KETTINGSPANBOUT EN KETTINGSPANNER

