



# LG

Life's Good

North/Latin America  
Europe/Africa  
Asia/Oceania

Internal Use Only

<http://aic.lgservice.com>  
<http://eic.lgservice.com>  
<http://biz.lgservice.com>

# LED TV

# SERVICE MANUAL

CHASSIS : LC43B

MODEL: 47LB5610 47LB5610-CD

## CAUTION

BEFORE SERVICING THE CHASSIS,  
READ THE SAFETY PRECAUTIONS IN THIS MANUAL.

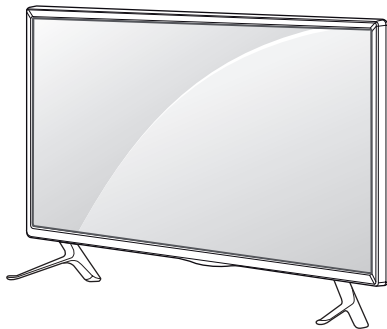

# CONTENTS

<b>CONTENTS .....</b>	<b>2</b>
<b>SAFETY PRECAUTIONS .....</b>	<b>3</b>
<b>SERVICING PRECAUTIONS .....</b>	<b>4</b>
<b>SPECIFICATION .....</b>	<b>6</b>
<b>ADJUSTMENT INSTRUCTION .....</b>	<b>8</b>
<b>BLOCK DIAGRAM.....</b>	<b>15</b>
<b>EXPLODED VIEW .....</b>	<b>16</b>
<b>SCHEMATIC CIRCUIT DIAGRAM .....</b>	

# SAFETY PRECAUTIONS

## IMPORTANT SAFETY NOTICE

Many electrical and mechanical parts in this chassis have special safety-related characteristics. These parts are identified by  $\triangle$  in the Schematic Diagram and Exploded View.

It is essential that these special safety parts should be replaced with the same components as recommended in this manual to prevent Shock, Fire, or other Hazards.

Do not modify the original design without permission of manufacturer.

### General Guidance

An **isolation Transformer should always be used** during the servicing of a receiver whose chassis is not isolated from the AC power line. Use a transformer of adequate power rating as this protects the technician from accidents resulting in personal injury from electrical shocks.

It will also protect the receiver and its components from being damaged by accidental shorts of the circuitry that may be inadvertently introduced during the service operation.

If any fuse (or Fusible Resistor) in this TV receiver is blown, replace it with the specified.

When replacing a high wattage resistor (Oxide Metal Film Resistor, over 1 W), keep the resistor 10 mm away from PCB.

Keep wires away from high voltage or high temperature parts.

### Before returning the receiver to the customer,

always perform an **AC leakage current check** on the exposed metallic parts of the cabinet, such as antennas, terminals, etc., to be sure the set is safe to operate without damage of electrical shock.

### Leakage Current Cold Check(Antenna Cold Check)

With the instrument AC plug removed from AC source, connect an electrical jumper across the two AC plug prongs. Place the AC switch in the on position, connect one lead of ohm-meter to the AC plug prongs tied together and touch other ohm-meter lead in turn to each exposed metallic parts such as antenna terminals, phone jacks, etc.

If the exposed metallic part has a return path to the chassis, the measured resistance should be between 1 M $\Omega$  and 5.2 M $\Omega$ .

When the exposed metal has no return path to the chassis the reading must be infinite.

An other abnormality exists that must be corrected before the receiver is returned to the customer.

### Leakage Current Hot Check (See below Figure)

Plug the AC cord directly into the AC outlet.

### Do not use a line Isolation Transformer during this check.

Connect 1.5 K / 10 watt resistor in parallel with a 0.15 uF capacitor between a known good earth ground (Water Pipe, Conduit, etc.) and the exposed metallic parts.

Measure the AC voltage across the resistor using AC voltmeter with 1000 ohms/volt or more sensitivity.

Reverse plug the AC cord into the AC outlet and repeat AC voltage measurements for each exposed metallic part. Any voltage measured must not exceed 0.75 volt RMS which corresponds to 0.5 mA.

In case any measurement is out of the limits specified, there is possibility of shock hazard and the set must be checked and repaired before it is returned to the customer.

### Leakage Current Hot Check circuit

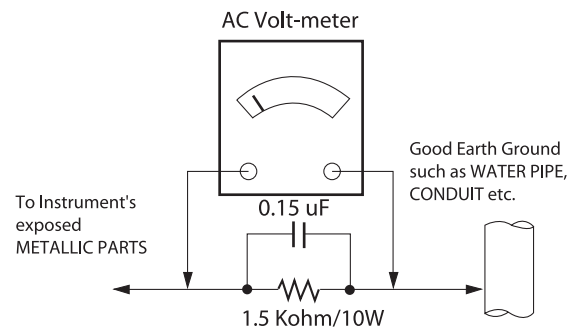

When 25A is impressed between Earth and 2nd Ground for 1 second, Resistance must be less than 0.1  $\Omega$

\*Base on Adjustment standard

# SERVICING PRECAUTIONS

**CAUTION:** Before servicing receivers covered by this service manual and its supplements and addenda, read and follow the **SAFETY PRECAUTIONS** on page 3 of this publication.

**NOTE:** If unforeseen circumstances create conflict between the following servicing precautions and any of the safety precautions on page 3 of this publication, always follow the safety precautions. Remember: Safety First.

## General Servicing Precautions

1. Always unplug the receiver AC power cord from the AC power source before;
  - a. Removing or reinstalling any component, circuit board module or any other receiver assembly.
  - b. Disconnecting or reconnecting any receiver electrical plug or other electrical connection.
  - c. Connecting a test substitute in parallel with an electrolytic capacitor in the receiver.  
**CAUTION:** A wrong part substitution or incorrect polarity installation of electrolytic capacitors may result in an explosion hazard.
2. Test high voltage only by measuring it with an appropriate high voltage meter or other voltage measuring device (DVM, FETVOM, etc) equipped with a suitable high voltage probe. Do not test high voltage by "drawing an arc".
3. Do not spray chemicals on or near this receiver or any of its assemblies.
4. Unless specified otherwise in this service manual, clean electrical contacts only by applying the following mixture to the contacts with a pipe cleaner, cotton-tipped stick or comparable non-abrasive applicator; 10 % (by volume) Acetone and 90 % (by volume) isopropyl alcohol (90 % - 99 % strength)  
**CAUTION:** This is a flammable mixture.  
Unless specified otherwise in this service manual, lubrication of contacts is not required.
5. Do not defeat any plug/socket B+ voltage interlocks with which receivers covered by this service manual might be equipped.
6. Do not apply AC power to this instrument and/or any of its electrical assemblies unless all solid-state device heat sinks are correctly installed.
7. Always connect the test receiver ground lead to the receiver chassis ground before connecting the test receiver positive lead.  
Always remove the test receiver ground lead last.
8. Use with this receiver only the test fixtures specified in this service manual.  
**CAUTION:** Do not connect the test fixture ground strap to any heat sink in this receiver.

## Electrostatically Sensitive (ES) Devices

Some semiconductor (solid-state) devices can be damaged easily by static electricity. Such components commonly are called Electrostatically Sensitive (ES) Devices. Examples of typical ES devices are integrated circuits and some field-effect transistors and semiconductor "chip" components. The following techniques should be used to help reduce the incidence of component damage caused by static by static electricity.

1. Immediately before handling any semiconductor component or semiconductor-equipped assembly, drain off any electrostatic charge on your body by touching a known earth ground. Alternatively, obtain and wear a commercially available discharging wrist strap device, which should be removed to prevent potential shock reasons prior to applying power to the unit under test.

2. After removing an electrical assembly equipped with ES devices, place the assembly on a conductive surface such as aluminum foil, to prevent electrostatic charge buildup or exposure of the assembly.
3. Use only a grounded-tip soldering iron to solder or unsolder ES devices.
4. Use only an anti-static type solder removal device. Some solder removal devices not classified as "anti-static" can generate electrical charges sufficient to damage ES devices.
5. Do not use freon-propelled chemicals. These can generate electrical charges sufficient to damage ES devices.
6. Do not remove a replacement ES device from its protective package until immediately before you are ready to install it. (Most replacement ES devices are packaged with leads electrically shorted together by conductive foam, aluminum foil or comparable conductive material).
7. Immediately before removing the protective material from the leads of a replacement ES device, touch the protective material to the chassis or circuit assembly into which the device will be installed.  
**CAUTION:** Be sure no power is applied to the chassis or circuit, and observe all other safety precautions.
8. Minimize bodily motions when handling unpackaged replacement ES devices. (Otherwise harmless motion such as the brushing together of your clothes fabric or the lifting of your foot from a carpeted floor can generate static electricity sufficient to damage an ES device.)

## General Soldering Guidelines

1. Use a grounded-tip, low-wattage soldering iron and appropriate tip size and shape that will maintain tip temperature within the range of 500 °F to 600 °F.
2. Use an appropriate gauge of RMA resin-core solder composed of 60 parts tin/40 parts lead.
3. Keep the soldering iron tip clean and well tinned.
4. Thoroughly clean the surfaces to be soldered. Use a mall wire-bristle (0.5 inch, or 1.25 cm) brush with a metal handle. Do not use freon-propelled spray-on cleaners.
5. Use the following unsoldering technique
  - a. Allow the soldering iron tip to reach normal temperature. (500 °F to 600 °F)
  - b. Heat the component lead until the solder melts.
  - c. Quickly draw the melted solder with an anti-static, suction-type solder removal device or with solder braid.  
**CAUTION:** Work quickly to avoid overheating the circuit board printed foil.
6. Use the following soldering technique.
  - a. Allow the soldering iron tip to reach a normal temperature (500 °F to 600 °F)
  - b. First, hold the soldering iron tip and solder the strand against the component lead until the solder melts.
  - c. Quickly move the soldering iron tip to the junction of the component lead and the printed circuit foil, and hold it there only until the solder flows onto and around both the component lead and the foil.  
**CAUTION:** Work quickly to avoid overheating the circuit board printed foil.
  - d. Closely inspect the solder area and remove any excess or splashed solder with a small wire-bristle brush.

### IC Remove/Replacement

Some chassis circuit boards have slotted holes (oblong) through which the IC leads are inserted and then bent flat against the circuit foil. When holes are the slotted type, the following technique should be used to remove and replace the IC. When working with boards using the familiar round hole, use the standard technique as outlined in paragraphs 5 and 6 above.

#### Removal

1. Desolder and straighten each IC lead in one operation by gently prying up on the lead with the soldering iron tip as the solder melts.
2. Draw away the melted solder with an anti-static suction-type solder removal device (or with solder braid) before removing the IC.

#### Replacement

1. Carefully insert the replacement IC in the circuit board.
2. Carefully bend each IC lead against the circuit foil pad and solder it.
3. Clean the soldered areas with a small wire-bristle brush. (It is not necessary to reapply acrylic coating to the areas).

### "Small-Signal" Discrete Transistor Removal/Replacement

1. Remove the defective transistor by clipping its leads as close as possible to the component body.
2. Bend into a "U" shape the end of each of three leads remaining on the circuit board.
3. Bend into a "U" shape the replacement transistor leads.
4. Connect the replacement transistor leads to the corresponding leads extending from the circuit board and crimp the "U" with long nose pliers to insure metal to metal contact then solder each connection.

#### Power Output, Transistor Device

##### Removal/Replacement

1. Heat and remove all solder from around the transistor leads.
2. Remove the heat sink mounting screw (if so equipped).
3. Carefully remove the transistor from the heat sink of the circuit board.
4. Insert new transistor in the circuit board.
5. Solder each transistor lead, and clip off excess lead.
6. Replace heat sink.

#### Diode Removal/Replacement

1. Remove defective diode by clipping its leads as close as possible to diode body.
2. Bend the two remaining leads perpendicular y to the circuit board.
3. Observing diode polarity, wrap each lead of the new diode around the corresponding lead on the circuit board.
4. Securely crimp each connection and solder it.
5. Inspect (on the circuit board copper side) the solder joints of the two "original" leads. If they are not shiny, reheat them and if necessary, apply additional solder.

#### Fuse and Conventional Resistor

##### Removal/Replacement

1. Clip each fuse or resistor lead at top of the circuit board hollow stake.
2. Securely crimp the leads of replacement component around notch at stake top.

3. Solder the connections.

**CAUTION:** Maintain original spacing between the replaced component and adjacent components and the circuit board to prevent excessive component temperatures.

### Circuit Board Foil Repair

Excessive heat applied to the copper foil of any printed circuit board will weaken the adhesive that bonds the foil to the circuit board causing the foil to separate from or "lift-off" the board. The following guidelines and procedures should be followed whenever this condition is encountered.

#### At IC Connections

To repair a defective copper pattern at IC connections use the following procedure to install a jumper wire on the copper pattern side of the circuit board. (Use this technique only on IC connections).

1. Carefully remove the damaged copper pattern with a sharp knife. (Remove only as much copper as absolutely necessary).
2. Carefully scratch away the solder resist and acrylic coating (if used) from the end of the remaining copper pattern.
3. Bend a small "U" in one end of a small gauge jumper wire and carefully crimp it around the IC pin. Solder the IC connection.
4. Route the jumper wire along the path of the out-away copper pattern and let it overlap the previously scraped end of the good copper pattern. Solder the overlapped area and clip off any excess jumper wire.

#### At Other Connections

Use the following technique to repair the defective copper pattern at connections other than IC Pins. This technique involves the installation of a jumper wire on the component side of the circuit board.

1. Remove the defective copper pattern with a sharp knife. Remove at least 1/4 inch of copper, to ensure that a hazardous condition will not exist if the jumper wire opens.
2. Trace along the copper pattern from both sides of the pattern break and locate the nearest component that is directly connected to the affected copper pattern.
3. Connect insulated 20-gauge jumper wire from the lead of the nearest component on one side of the pattern break to the lead of the nearest component on the other side. Carefully crimp and solder the connections.

**CAUTION:** Be sure the insulated jumper wire is dressed so the it does not touch components or sharp edges.

# SPECIFICATION

NOTE : Specifications and others are subject to change without notice for improvement.

## 1. Application range

This specification is applied to the LED TV used LC43B chassis.

## 2. Requirement for Test

Each part is tested as below without special appointment.

- 1) Temperature: 25 °C ± 5 °C(77 °F ± 9 °F), CST: 40 °C ± 5 °C
- 2) Relative Humidity: 65 % ± 10 %
- 3) Power Voltage  
: Standard input voltage (AC 100-240 V~, 50/60 Hz)  
\* Standard Voltage of each products is marked by models.
- 4) Specification and performance of each parts are followed each drawing and specification by part number in accordance with BOM.
- 5) The receiver must be operated for about 5 minutes prior to the adjustment.

## 3. Test method

- 1) Performance: LGE TV test method followed
- 2) Demanded other specification
  - Safety : CE, IEC specification
  - EMC : CE, IEC

## 4. Model General Specification

No.	Item	Specification	Remarks
1.	Market	Hong Kong	
2.	Broadcasting system	1) PAL-DK 2) PAL-I 3) NTSC-M 4) DTMB 5) DVB-C	DTMB : DMB-T + ADTB-T
3.	Channel Storage	1500EA	Maximum number of storable program for ATV /DTV
4.	Channel Coverage		Digital TV DTMB : 21~69 DVB-C : 52.5 MHz ~866MHz Analogue TV PAL D/K : VHF/UHF 1 ~ 69, Cable 1 ~ 47 PAL I : VHF/UHF 1 ~ 69, Cable 1 ~ 47 NTSC M : VHF/UHF 2 ~ 78, Cable 1 ~ 71
5.	Receiving system	Analog : Upper Heterodyne Digital : COFDM, QAM	▶ DTMB (Carrier, Code Rate, Constellation, Frame Header, Interleaving) MODE : 3780, 0.4/0.6, 4/16/64QAM, PN945, 720 QPSK : 1/2, 2/3, 3/4, 5/6, 7/8 16-QAM : 1/2, 2/3, 3/4, 5/6, 7/8 64-QAM : 1/2, 2/3, 3/4, 5/6, 7/8  ▶ DVB-C - Symbolrate : 4.0Msymbols/s to 7.2Msymbols/s - Modulation : 16QAM, 64-QAM, 128-QAM and 256-QAM
6.	Video(Composite) Input	PAL, SECAM, NTSC	Rear 1EA
7.	Component Input	Y/Cb/Cr, Y/Pb/Pr	Rear 1EA
8.	HDMI Input	HDMI1-DTV/DVI HDMI2-DTV	PC(HDMI version 1.4), Support HDCP
9.	Audio Input	Component, AV	L/R Input
10.	USB	For My Media(Movie/Photo/Music List) and SVC	1EA(JPEG, MP3, DivX HD)

## 5. Component Video Input (Y, PB, PR)

No.	Specification	H-freq(kHz)	V-freq(Hz)	Proposed
	Resolution	H-freq(kHz)	V-freq(Hz)	
1.	720×480	15.73	60.00	SDTV, DVD 480i
2.	720×480	15.63	59.94	SDTV, DVD 480i
3.	720×480	31.47	59.94	480p
4.	720×480	31.50	60.00	480p
5.	720×576	15.625	50.00	SDTV, DVD 625 Line
6.	720×576	31.25	50.00	HDTV 576p
7.	1280×720	45.00	50.00	HDTV 720p
8.	1280×720	44.96	59.94	HDTV 720p
9.	1280×720	45.00	60.00	HDTV 720p
10.	1920×1080	28.125	50.00	HDTV 1080i
11.	1920×1080	33.75	60.00	HDTV 1080i
12.	1920×1080	33.72	59.94	HDTV 1080i
13.	1920×1080	26.97	23.976	HDTV 1080p
14.	1920×1080	27.00	24	HDTV 1080p
15.	1920×1080	33.71	29.97	HDTV 1080p
16.	1920×1080	33.75	30	HDTV 1080p
17.	1920×1080	56.25	50	HDTV 1080p
18.	1920×1080	67.432	59.94	HDTV 1080p
19.	1920×1080	67.5	60	HDTV 1080p

## 6. HDMI Input

### 6.1. DTV mode

No.	Resolution	H-freq(kHz)	V-freq.(kHz)	Pixel clock(MHz)	Proposed
1.	720*480	31.469 / 31.5	59.94 / 60	27.00/27.03	SDTV 480P
2.	720*576	31.25	50	54	SDTV 576P
3.	1280*720	37.500	50	74.25	HDTV 720P
4.	1280*720	44.96 / 45	59.94 / 60	74.17/74.25	HDTV 720P
5.	1920*1080	33.72 / 33.75	59.94 / 60	74.17/74.25	HDTV 1080I
6.	1920*1080	28.125	50.00	74.25	HDTV 1080I
7.	1920*1080	26.97 / 27	23.97 / 24	74.17/74.25	HDTV 1080P
8.	1920*1080	33.716/33.75	29.976/30.00	74.25	HDTV 1080P
9.	1920*1080	56.250	50	148.5	HDTV 1080P
10.	1920*1080	67.43 / 67.5	59.94 / 60	148.35/148.50	HDTV 1080P

### 6.2. PC mode

No.	Resolution	H-freq(kHz)	V-freq.(Hz)	Pixel clock(MHz)	Proposed	Remark
1.	640*350 @70Hz	31.468	70.09	25.17	EGA	
2.	720*400 @70Hz	31.469	70.08	28.321	DOS	
3.	640*480 @60Hz	31.469	59.940	25.175	VESA(VGA)	
4.	800*600 @60Hz	37.879	60.31	40.000	VESA(SVGA)	
5.	1024*768 @60Hz	48.363	60.00	65.000	VESA(XGA)	
6.	1152*864 @60Hz	54.348	60.053	80.002	VESA	
7.	1280*1024 @60Hz	63.981	60.020	108	VESA(SXGA)	FHD only
8.	1360*768 @60Hz	47.712	60.015	85.5	VESA(WXGA)	
9.	1920*1080 @60Hz	67.5	60.0	148.5	WUXGA (Reduced blanking)	FHD only

# ADJUSTMENT INSTRUCTION

## 1. Application Range

This specification sheet is applied to all of the LED TV with LC43B chassis.

## 2. Designation

- (1) The adjustment is according to the order which is designated and which must be followed, according to the plan which can be changed only on agreeing.
- (2) Power adjustment : Free Voltage.
- (3) Magnetic Field Condition: Nil.
- (4) Input signal Unit: Product Specification Standard.
- (5) Reserve after operation: Above 5 Minutes (Heat Run)  
Temperature : at 25 °C ± 5 °C  
Relative humidity : 65 ± 10 %  
Input voltage : 220 V~, 60 Hz
- (6) Adjustment equipments  
: Color Analyzer(CA-210 or CA-110), Service remote control.
- (7) Push the "IN STOP" key - For memory initialization.

Case1 : Software version up

1. After downloading S/W by USB , TV set will reboot automatically.
2. Push "In-stop" key.
3. Push "Power on" key.
4. Function inspection
5. After function inspection, Push "In-stop" key.

Case2 : Function check at the assembly line

1. When TV set is entering on the assembly line, Push "In-stop" key at first.
2. Push "Power on" key for turning it on.  
→ If you push "Power on" key, TV set will recover channel information by itself.
3. After function inspection, Push "In-stop" key.

## 3. Main PCB check process

- APC - After Manual-Insert, executing APC

### \* Boot file Download

- (1) Execute ISP program "Mstar ISP Utility" and then click "Config" tab.
- (2) Set as below, and then click "Auto Detect" and check "OK" message.  
If "Error" is displayed, check connection between computer, jig, and set.
- (3) Click "Read" tab, and then load download file(XXXX.bin) by clicking "Read"

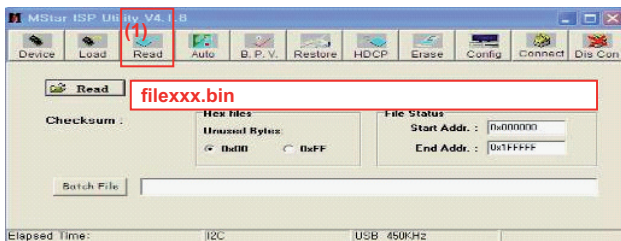

- (4) Click "Connect" tab. If "Can't" is displayed, check connection between computer, jig and set.

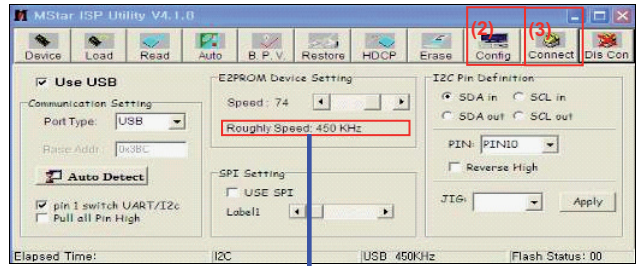

Please Check the Speed :  
To use speed between  
from 200KHz to 400KHz

- (5) Click "Auto" tab and set as below.
- (6) Click "Run".
- (7) After downloading, check "OK" message.

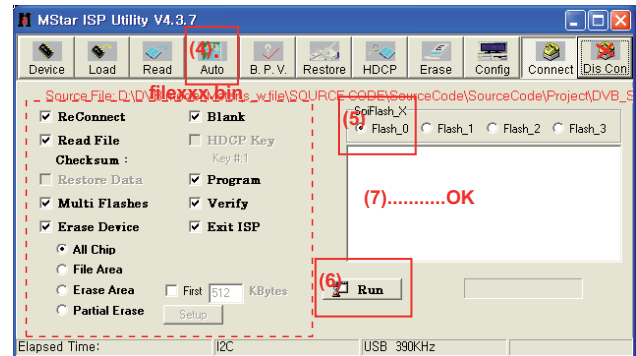

### \* USB DOWNLOAD(\*.epk file download)

- (1) Put the USB Stick to the USB socket.
- (2) Automatically detecting update file in USB Stick.  
- If version of update file in USB Stick is lower, it will not work. But version of update file is higher, USB data will be detected automatically.

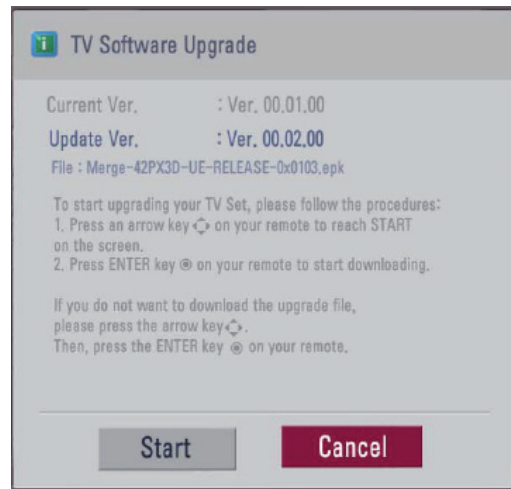



(3) Show the message "Copying files from memory".



(4) Updating is starting.

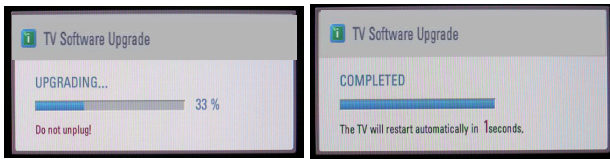

(5) Updating Completed, The TV will restart automatically.

(6) If your TV is turned on, check your updated version and Tool option. (explain the Tool option, next stage)

\* If updated version is higher than what TV has, the TV can lose all channel data. In this case, you have to channel recover. If all channel data is cleared, you didn't have a DTV/ATV test on production line.

\* After downloading, have to adjust Tool Option again.

- (1) Push "IN-START" key in service remote control.
- (2) Select "Tool Option 1" and push "OK" key.
- (3) Punch in the number. (Each model has their number)
- (4) Completed selecting Tool option.

## 4. ADC Process

### 4.1. ADC

- Enter Service Mode by pushing "ADJ" key,
- Enter Internal ADC mode by pushing "▶" key at "8. ADC Calibration".

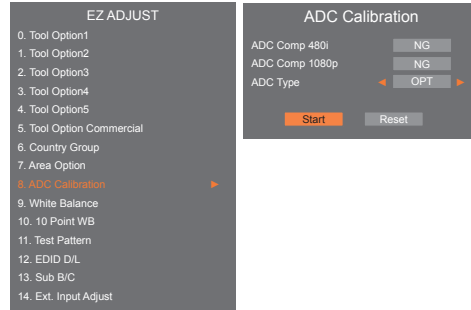

<Caution> Using "P-ONLY" key of the Adjustment remote control, power on TV.

\* ADC Calibration Protocol (RS232)

NO	Item	CMD 1	CMD 2	Data 0	
Enter Adjust MODE	Adjust 'Mode In'	A	A	0 0	When transfer the 'Mode In', Carry the command.
ADC adjust	ADC Adjust	A	D	1 0	Automatically adjustment (The use of a internal pattern)

Adjust Sequence

- aa 00 00 [Enter Adjust Mode]
- xb 00 40 [Component1 Input (480i)]
- ad 00 10 [Adjust 480i Comp1]
- xb 00 60 [RGB Input (1024\*768)]
- ad 00 10 [Adjust 1024\*768 RGB]
- aa 00 90 End Adjust mode

\* Required equipment : Adjustment remote control.

### 4.2. Function Check

#### 4.2.1. Check display and sound

- Check Input and Signal items.

- (1) TV
- (2) AV (CVBS)
- (3) COMPONENT (480i)
- (4) HDMI

\* Display and Sound check is executed by Remote control.

<Caution> Not to push the "INSTOP" key after completion if the function inspection.

## 5. Total Assembly line process

### 5.1. Adjustment Preparation

- W/B Equipment condition  
CA210: LED → CH14, Test signal: Inner pattern(80IRE)
- Above 5 minutes H/run in the inner pattern. ("power on" key of Adjustment remote control)

\* The spec of color temperature and coordinate.

#### 5.1.1. W/B adj. Objective & How-it-works

- Objective: To reduce each Panel's W/B deviation
- How-it-works: When R/G/B gain in the OSD is at 192, it means the panel is at its Full Dynamic Range.  
In order to prevent saturation of Full Dynamic range and data, one of R/G/B is fixed at 192, and the other two is lowered to find the desired value.
- Adj. condition: normal temperature
  - Surrounding Temperature:  $25 \pm 5$  °C
  - Warm-up time: About 5 Min
  - Surrounding Humidity: 20% ~ 80%
  - Before White balance adjustment, Keep power on status, don't power off

\* If Model is POLA model

Case : Cool Mode

- Purpose : Adjust the color temperature to reduce the deviation of the module color temperature.
- Principle : To adjust the white balance without the saturation, Fix the G gain to 172 (default data) and change the others ( R/B Gain ).
- Adjustment mode : mode - Cool

Case : Medium / Warm Mode

- Purpose : Adjust the color temperature to reduce the deviation of the module color temperature.
- Principle : To adjust the white balance without the saturation, Fix the one of R/G/B gain to 192 (default data) and decrease the others.
- Adjustment mode : Two modes - Medium / Warm

Mode	Color Temp	Color coordinate	Remark
Cool (C50)	13,000 K	X=0.271 ( $\pm 0.002$ ) Y=0.270 ( $\pm 0.002$ )	<Test Signal> - Inner pattern for W/B adjust - External white pattern(80IRE, 204gray)
Medium(0)	9,300 K	X=0.286 ( $\pm 0.002$ ) Y=0.289 ( $\pm 0.002$ )	
Warm(W50)	6,500 K	X=0.313 ( $\pm 0.002$ ) Y=0.329 ( $\pm 0.002$ )	

\* W/B Table( Netcast4.0 Model)

CA210 : CH 14, Test signal : Inner pattern (80IRE)

Normal line - Standard color coordinate and temperature using CA-1000(by H/R time)

NC4.0	Aging time (Min)	Cool		Medium		Warm	
		x	y	x	y	x	y
		271	270	286	289	313	329
1	0-2	282	289	297	308	324	348
2	3-5	281	287	296	306	323	346
3	6-9	279	284	294	303	321	343
4	10-19	277	280	292	299	319	339
5	20-35	275	277	290	296	317	336
6	36-49	274	274	289	293	316	333
7	50-79	273	272	288	291	315	331
8	80-119	272	271	287	290	314	330
9	Over 120	271	270	286	289	313	329

Aging chamber line - Standard color coordinate and temperature using CA-1000(by H/R time)

NC4.0	Aging time (Min)	Cool		Medium		Warm	
		x	y	x	y	x	y
		271	270	285	293	313	329
1	0-5	280	285	294	308	319	340
2	6-10	276	280	290	303	315	335
3	11-20	272	275	286	298	311	330
4	21-30	269	272	283	295	308	327
5	31-40	267	268	281	291	306	323
6	41-50	266	265	280	288	305	320
7	51-80	265	263	279	286	304	318
8	81-119	264	261	278	284	303	316
9	Over 120	264	260	278	283	303	315

\* When Model produce in Gumi Factory at Winter(Jan, Feb)  
Normal line

NC4.0	Aging time (Min)	Cool		Medium		Warm	
		x	y	x	y	x	y
		271	270	286	289	313	329
1	0-5	286	295	301	314	328	354
2	6-10	284	290	299	309	326	349
3	11-20	282	287	297	306	324	346
4	21-30	279	283	294	302	321	342
5	31-40	276	278	291	297	318	337
6	41-50	274	275	289	294	316	334
7	51-80	273	272	288	291	315	331
8	81-119	272	271	287	290	314	330
9	Over 120	271	270	286	289	313	329

\* AUO, Sharp, CSOT use Model(If Cool spec 13000K)

NC4.0	Cool		Medium		Warm	
	x	y	x	y	x	y
spec	271	270	286	289	313	329
target	278	280	293	299	320	339

\* Connecting picture of the measuring instrument  
(On Automatic control)  
Inside Pattern is used when W/B is controlled. Connect to auto controller or push Adjustment Remote control POWER ON → Enter the mode of White-Balance, the pattern will come out.

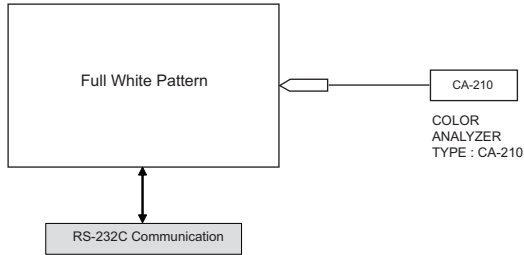

**\* Auto-control interface and directions**

- (1) Adjust in the place where the influx of light like floodlight around is blocked. (Illumination is less than 10 lux).
- (2) Adhere closely the Color analyzer(CA210) to the module less than 10 cm distance, keep it with the surface of the Module and Color analyzer's probe vertically.(90°(± 2.5°))
- (3) Aging time
  - After aging start, keep the power on (no suspension of power supply) and heat-run over 5 minutes.
  - Using 'no signal' or 'full white pattern' or the others, check the back light on.

▪ Auto adjustment Map(RS-232C)

RS-232C COMMAND

[CMD ID DATA]

Wb 00 00 White Balance Start  
Wb 00 ff White Balance End

	RS-232C COMMAND [CMD ID DATA]			MIN	CENTER (DEFAULT)			MAX
	Cool	Mid	Warm		Cool	Mid	Warm	
R Gain	jg	Ja	jd	00	172	192	192	192
G Gain	jh	Jb	je	00	172	192	192	192
B Gain	ji	Jc	jf	00	192	192	172	192
R Cut					64	64	64	128
G Cut					64	64	64	128
B Cut					64	64	64	128

**\* Manual W/B process using adjust Remote control.**

- Color Temperature : COOL, Medium, Warm
- One of R Gain/ G Gain/ B Gain should be kept on 0xC0, and adjust other two lower than C0. (when R/G/B Gain are all C0, it is the FULL Dynamic Range of Module)
- After enter Service Mode by pushing “ADJ” key,
- Enter White Balance by pushing “▶” key at “9. White Balance”.

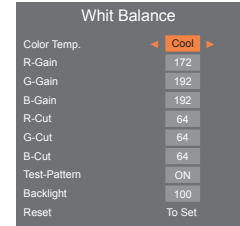
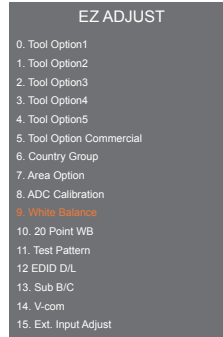

- For manual adjustment, it is also possible by the following sequence.

- (1) Set TV in Adj. mode using POWER ON
  - (2) Zero Calibrate the probe of Color Analyzer, then place it on the center of LCD module within 10cm of the surface
  - (3) Press ADJ key → EZ adjust using adj. R/C → 8. White-Balance then press the cursor to the right (KEY▶). When KEY(▶) is pressed 206 Gray internal pattern will be displayed.
  - (4) Adjust Cool modes
    - 1) Fix the one of R/G/B gain to 192 (default data) and decrease the others. (If G gain is adjusted over 172 and R and B gain less than 192, Adjust is O.K.)
    - 2) If G gain is less than 172, Increase G gain by up to 172, and then increase R gain and G gain same amount of increasing G gain.
    - 3) If R gain or B gain is over 255, readjust G gain less than 172, Conform to R gain is 255 or B gain is 255
  - (5) Adjust two modes (Medium/Warm) Fix the one of R/G/B gain to 192 (default data) and decrease the others.
  - (6) Adj. is completed, Exit adjust mode using “EXIT” key on Remote control.
- If internal pattern is not available, use RF input In EZ Adj. menu
9. White Balance, you can select one of 2 Test-pattern: ON, OFF. Default is inner (ON).  
By selecting OFF, you can adjust using RF signal in 206 Gray pattern.

**\* CASE Cool**

First adjust the coordinate far away from the target value(x, y).

- 1) x, y > target
  - i) Decrease the R, G.
- 2) x, y < target
  - i) First decrease the B gain,
  - ii) Decrease the one of the others.
- 3) x > target, y < target
  - i) First decrease B, so make y a little more than the target.
  - ii) Adjust x value by decreasing the R.
- 4) x < target, y > target
  - i) First decrease B, so make x a little more than the target.
  - ii) Adjust x value by decreasing the G.

How to adjust

- 1) If G gain is adjusted over 172 and R gain and B gain less than 192, Adjust is O.K.
- 2) If G gain is less than 172, increase G gain by up to 172, and then increase R gain and B gain same amount of increasing G gain.
- 3) If R gain or B gain is over 255, Readjust G gain less than 172, Conform to R gain is 255 or B gain is 255.

**\* CASE Medium / Warm**

First adjust the coordinate far away from the target value(x, y).

- 1) x, y > target
  - i) Decrease the R, G.
- 2) x, y < target
  - i) First decrease the B gain,
  - ii) Decrease the one of the others.
- 3) x > target, y < target
  - i) First decrease B, so make y a little more than the target.
  - ii) Adjust x value by decreasing the R
- 4) x < target, y > target
  - i) First decrease B, so make x a little more than the target.
  - ii) Adjust x value by decreasing the G

\* After You finish all adjustments, Press "In-start" button and compare Tool option and Area option value with its BOM, if it is correctly same then unplug the AC cable.

If it is not same, then correct it same with BOM and unplug AC cable.

For correct it to the model's module from factory JIG model.

\* Push the "IN-STOP KEY" after completing the function inspection.

**5.2. DDC EDID Write (RGB 128Byte)**

- Connect D-sub Signal Cable to D-Sub Jack.
  - Write EDID DATA to EEPROM(24C02) by using DDC2B protocol.
  - Check whether written EDID data is correct or not.
- \* For SVC main Assembly, EDID have to be downloaded to Insert Process in advance.

**5.3. DDC EDID Write (HDMI 256Byte)**

- Connect HDMI Signal Cable to HDMI Jack.
  - Write EDID DATA to EEPROM(24C02) by using DDC2B protocol.
  - Check whether written EDID data is correct or not.
- \* For SVC main Assembly, EDID have to be downloaded to Insert Process in advance.

**5.4. EDID DATA**

- 1) All Data : HEXA Value
- 2) Changeable Data :
  - \*: Serial No : Controlled / Data:01
  - \*\* : Month : Controlled / Data:00
  - \*\*\*: Year : Controlled
  - \*\*\*\*: Check sum

**- Auto Download**

- After enter Service Mode by pushing "ADJ" key,
  - Enter EDID D/L mode.
  - Enter "START" by pushing "OK" key.
- \* Caution : Never connect HDMI & D-sub Cable when EDID downloaded

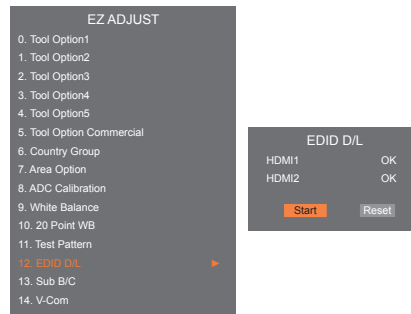

**\* Edid data and Model option download (RS232)**

NO	Item	CMD 1	CMD 2	Data 0	
Enter download Mode	Download 'Mode In'	A	A	0 0	When transfer the 'Mode In', Carry the command.
EDID data and Model option download	ADC Adjust	A	E	00 10	Automatically adjustment (The use of a internal pattern)

**- Manual Download**

[Caution]

- \* Use the proper signal cable for EDID Download
- Analog EDID : Pin3 exists
- Digital EDID : Pin3 exists
- Never connect HDMI & D-sub Cable at the same time.
- Use the proper cables below for EDID Writing.
- Download HDMI1/2/3 separately because each EDID data is different.



No.	Item	Condition	Hex Data
1	Manufacturer ID	GSM	1E6D
2	Version	Digital : 1	01
3	Revision	Digital : 3	03

(1) EDID Data  
- FHD 8BIT HDMI EDID DATA

0	1	2	3	4	5	6	7	8	9	A	B	C	D	E	F		
0	00	FF	FF	FF	FF	FF	FF	00	1E	6D	a			b			
10	c		01	03	80	A0	5A	78	0A	EE	91	A3	54	4C	99	26	
20	0F	50	54	A1	08	00	31	40	45	40	61	40	71	40	81	80	
30	01	01	01	01	01	01	02	3A	80	18	71	38	2D	40	58	2C	
40	45	00	A0	5A	00	00	00	1E	66	21	50	B0	51	00	1B	30	
50	40	70	36	00	A0	5A	00	00	00	1E	00	00	00	FD	00	3A	
60	3E	1E	53	10	00	0A	20	20	20	20	d			01	e		
70	d														01	e	
80	02	03	22	F1	4E	10	9F	04	13	05	14	03	02	12	20	21	
90	22	15	01	26	15	07	50	09	57	07	f						
A0	f		01	1D	80	18	71	1C	16	20	58	2C	25	00	20	C2	
B0	31	00	00	9E	01	1D	00	72	51	D0	1E	20	6E	28	55	00	
C0	20	C2	31	00	00	1E	02	3A	80	18	71	38	2D	40	58	2C	
D0	45	00	A0	5A	00	00	00	1E	01	1D	00	BC	52	D0	1E	20	
E0	B8	28	55	40	C4	8E	21	00	00	1E	00	00	00	00	00	00	
F0	00	00	00	00	00	00	00	00	00	00	00	00	00	00	00	e	

- HD HDMI EDID data (2D Model)

0	1	2	3	4	5	6	7	8	9	A	B	C	D	E	F		
0	00	FF	FF	FF	FF	FF	FF	00	1E	6D	a			b			
10	c		01	03	80	A0	5A	78	0A	EE	91	A3	54	4C	99	26	
20	0F	50	54	A1	08	00	31	40	45	40	61	40	71	40	01	01	
30	01	01	01	01	01	01	66	21	50	B0	51	00	1B	30	40	70	
40	36	00	40	84	63	00	00	1E	64	19	00	40	41	00	26	30	
50	18	88	03	06	40	84	63	00	00	18	00	00	00	FD	00	3A	
60	3E	1E	53	10	00	0A	20	20	20	20	d			01	e		
70	d														01	e	
80	02	03	22	F1	4E	10	1F	04	93	05	14	03	02	12	20	21	
90	22	15	01	26	15	07	50	09	57	07	f						
A0	80	1E	01	1D	80	18	71	1C	16	20	58	2C	25	00	A0	5A	
B0	00	00	00	9E	01	1D	00	72	51	D0	1E	20	6E	28	55	00	
C0	20	C2	31	00	00	1E	8C	0A	D0	8A	20	E0	2D	10	10	3E	
D0	96	00	A0	5A	00	00	00	18	02	3A	80	18	71	38	2D	40	
E0	58	2C	45	00	A0	5A	00	00	00	1E	00	00	00	00	00	00	
F0	00	00	00	00	00	00	00	00	00	00	00	00	00	00	00	e	

(2) Detail EDID Options are below

a. Product ID

Model Name	HEX	EDID Table	DDC Function
HD/FHD Model	0001	01 00	Analog/Digital

- b. Serial No: Controlled on production line.
- c. Month, Year: Controlled on production line:  
ex) Week : '01' -> '01'  
Year : '2012' -> '16' fix

d. Model Name(Hex):

cf) TV set's model name in EDID data is below.

MODEL NAME	MODEL NAME(HEX)
LG TV	00 00 00 FC 00 4C 47 20 54 56 0A 20 20 20 20 20 20 (LG TV)

e. Checksum: Changeable by total EDID data.

EDID C/S data		FHD-8BIT HDMI	FHD-10BIT HDMI	HD HDMI
Check Sum (Hex)	Block 0	41	41	75
	Block 1	25 (HDMI1) 15 (HDMI2)	DE (HDMI1) CE (HDMI2)	5B (HDMI1) 4B (HDMI2)

**5.5. Outgoing condition Configuration**

- When pressing IN-STOP key by Service remote control, Red LED are blinked alternatively. And then automatically turn off. (Must not AC power OFF during blinking)

**5.6. GND and HI-POT Test**

**5.5.1. GND & HI-POT auto-check preparation**

- (1) Check the POWER CABLE and SIGNAL CABLE insertion condition.

**5.6.2. GND & HI-POT auto-check**

- (1) Pallet moves in the station.(POWER CORD / AV CORD is tightly inserted)
- (2) Connect the AV JACK Tester.
- (3) Controller (GWS103-4) on.
- (4) GND Test (Auto)
  - If Test is failed, Buzzer operates.
  - If Test is passed, execute next process(Hi-pot test). (Remove A/V CORD from A/V JACK BOX)
- (5) HI-POT test (Auto)
  - If Test is failed, Buzzer operates.
  - If Test is passed, GOOD Lamp on and move to next process automatically.

**5.6.3. Checkpoint**

- (1) Test voltage
  - 1) 3 Poles
    - GND: 1.5 KV/min at 100 mA
    - SIGNAL: 3 KV/min at 100 mA
  - 2) 2 Poles
    - SIGNAL: 3 KV/min at 100 mA
- (2) TEST time: 1 second
- (3) TEST POINT
  - 1) 3 Poles
    - GND Test = POWER CORD GND and SIGNAL CABLE GND.
    - Hi-pot Test = POWER CORD GND and LIVE & NEUTRAL.
  - 2) 2 Poles
    - Hi-pot Test = Accessible Metal and LIVE & NEUTRAL.
- (4) LEAKAGE CURRENT: At 0.5 mArms

## 6. Model name & Serial No. download

- Press "Power on" key of service remote control (Baud rate : 115200 bps)
- Connect USB to RS232 cable at USB Jack.
- Write model name and serial number.
- Must check the model name and serial number at the Product/Service Info. (menu key → red key → select Product/Service info)



### 6.1. Signal TABLE

CMD	LENGTH	ADH	ADL	DATA_1	...	Data_n	CS	DELAY
-----	--------	-----	-----	--------	-----	--------	----	-------

CMD : A0h  
 LENGTH : 85~94h (1~16 bytes)  
 ADH : EEPROM Sub Address high (00~1F)  
 ADL : EEPROM Sub Address low (00~FF)  
 Data : Write data  
 CS : CMD + LENGTH + ADH + ADL + Data\_1 + ... + Data\_n  
 Delay : 20ms

### 6.2. Comand Set

Adjust mode	CMD(hex)	LENGTH(hex)	Description
EEPROM WRITE	A0h	84h+n	n-bytes Write (n = 1~16)

\* Description  
 FOS Default write : <7mode data> write  
 Vtotal, V\_Frequency, Sync\_Polarity, Htotal, Hstart, Vstart, 0, Phase  
 Data write : Model Name and Serial Number write in EEPROM,.

### 6.3. Method & notice

- (1) Serial number D/L is using of scan equipment.
- (2) Setting of scan equipment operated by Manufacturing Technology Group.
- (3) Serial number D/L must be conformed when it is produced in production line, because serial number D/L is mandatory by D-book 4.0.

\* Manual Download(Model Name and Serial Number)  
 If the TV set is downloaded by OTA or Service man, sometimes model name or serial number is initialized.(Not always)  
 There is impossible to download by bar code scan, so It need Manual download.

- 1) Press the "Instart" key of Adjustment remote control.
- 2) Go to the menu "6.Model Number D/L" like below photo.
- 3) Input the Factory model name or Serial number like photo.

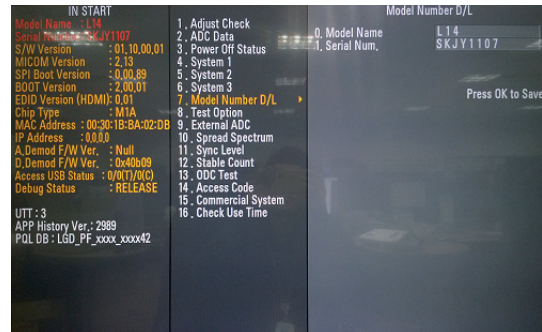

- 4) Check the model name Instart menu. → Factory name displayed.
- 5) Check the Product/Service Info.(Menu Key → Red Key → Select Product/Service Info.) → Buyer model displayed.

# BLOCK DIAGRAM

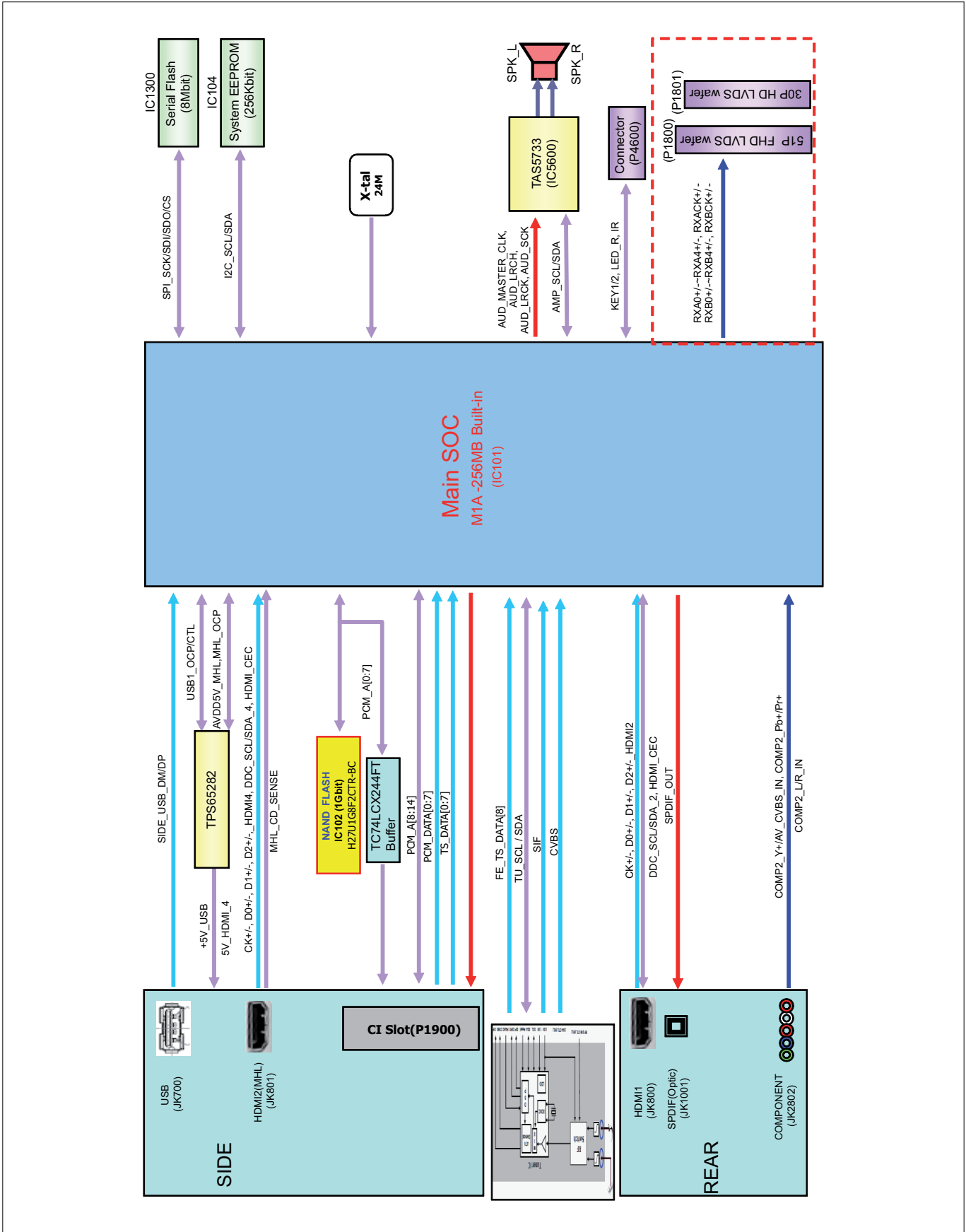

# EXPLODED VIEW

## IMPORTANT SAFETY NOTICE

Many electrical and mechanical parts in this chassis have special safety-related characteristics. These parts are identified by  $\Delta$  in the Schematic Diagram and EXPLODED VIEW. It is essential that these special safety parts should be replaced with the same components as recommended in this manual to prevent X-RADIATION, Shock, Fire, or other Hazards. Do not modify the original design without permission of manufacturer.

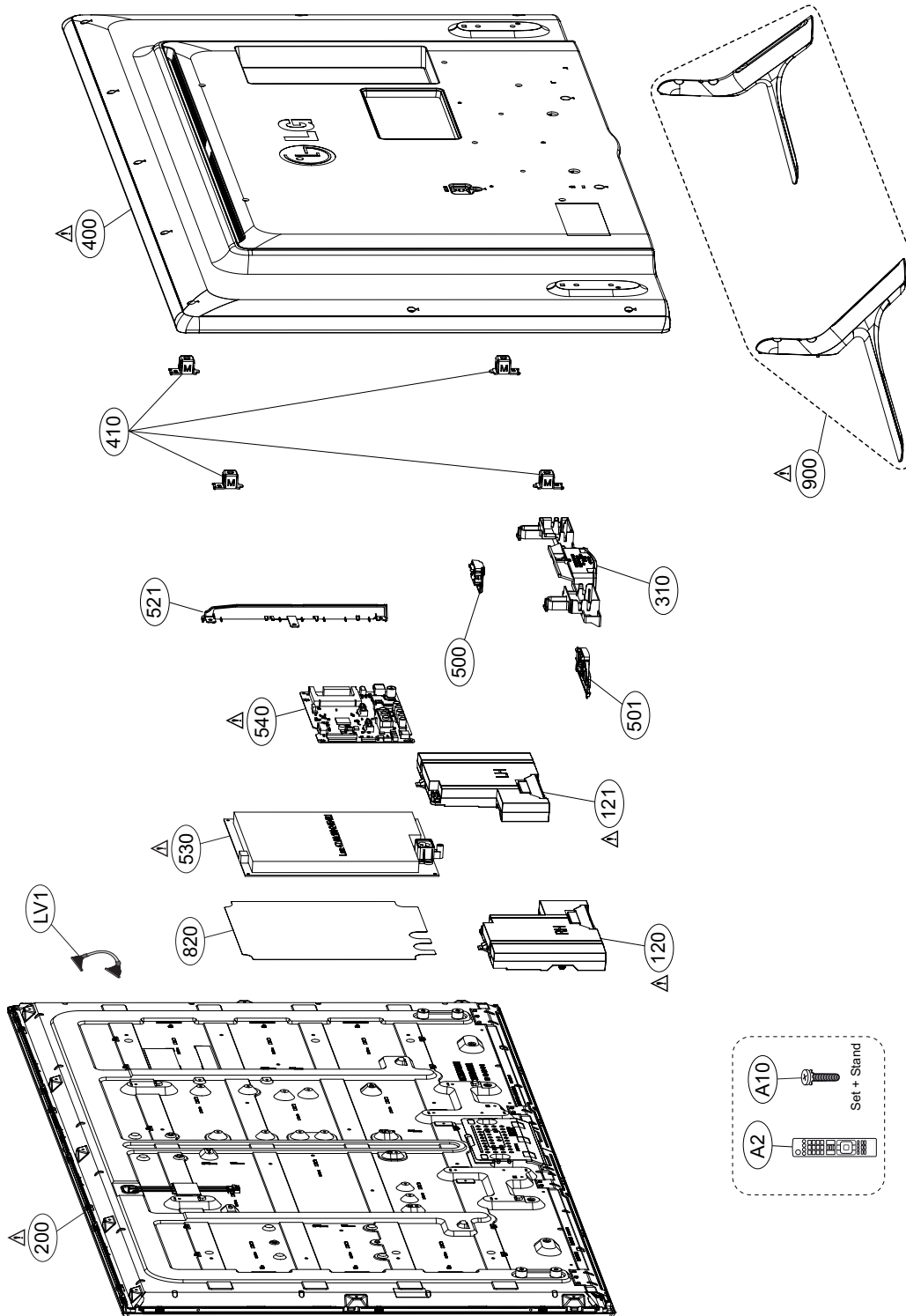



# L14 POWER BLOCK (POWER DETECT 2)

## FROM LIPS or POWER B/D

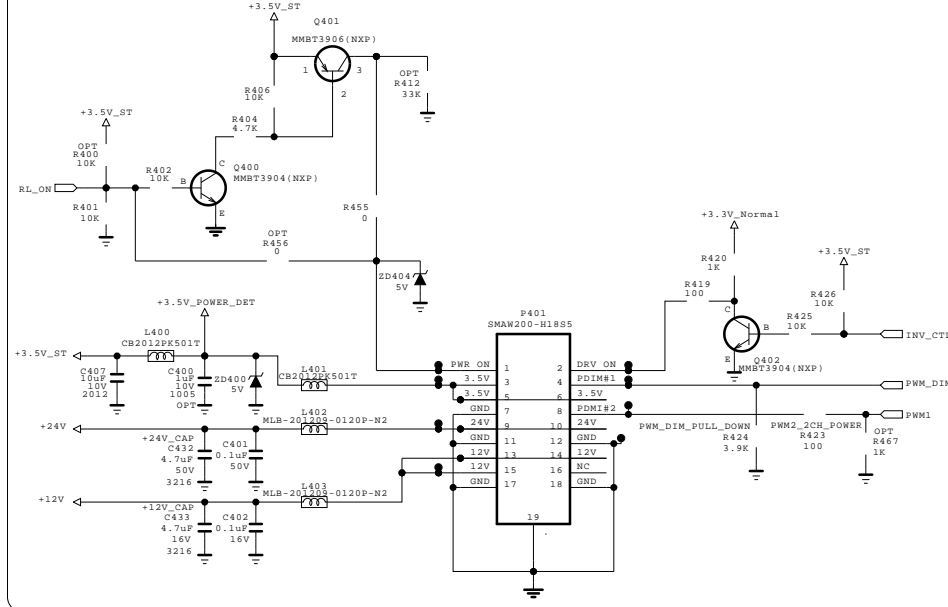

## +1.5V\_DDR

$$V_{out} = 1.25 * (1 + R2/R1) + I_{adj} * R2$$

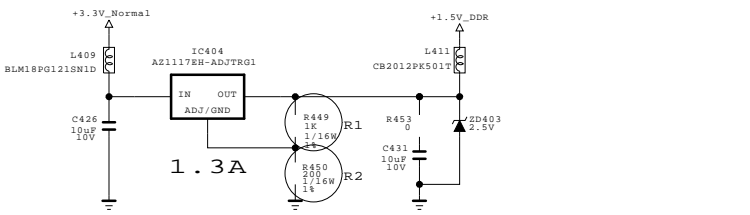

## +5V\_Normal & +5V\_USB with OCP

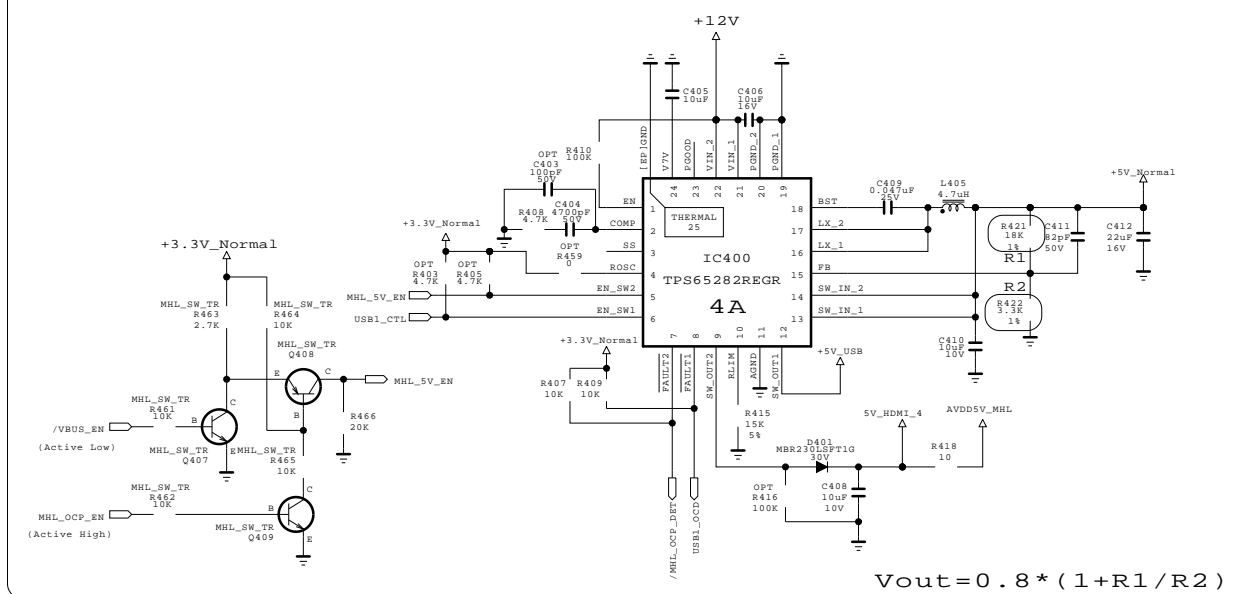

$$V_{out} = 0.8 * (1 + R1/R2)$$

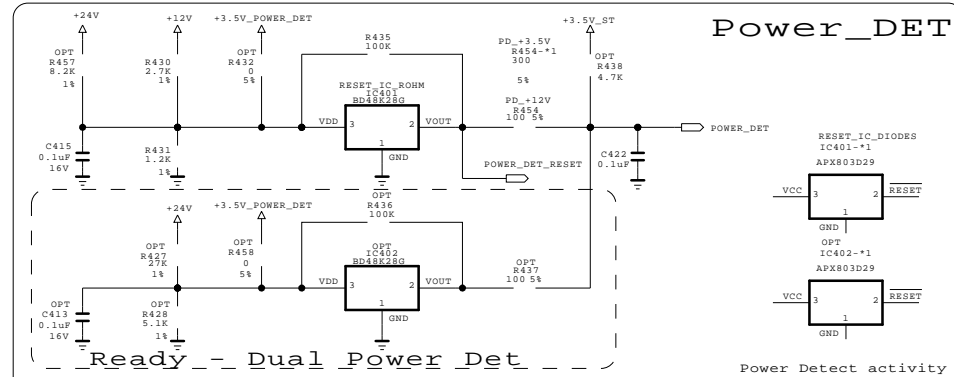

Detect Voltage	Now is	Use Circuit Designator
Power Detect +3.5V		R432, R454-*1, R438
Power Detect +12V	O	R430, R431, R454
Power Detect +24V		R457, R454

## +1.10V\_VDDC

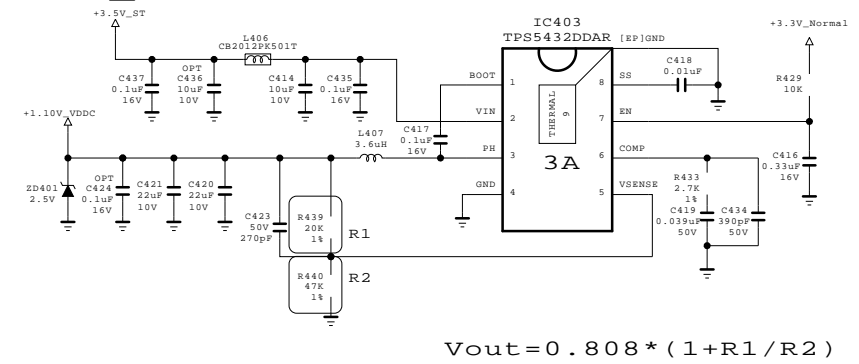

$$V_{out} = 0.808 * (1 + R1/R2)$$

## PANEL\_VCC

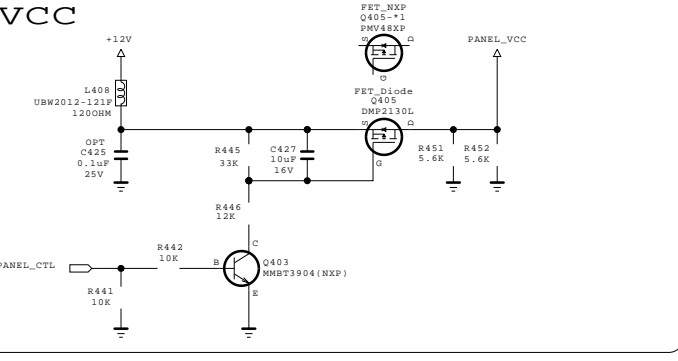

## +3.3V\_Normal

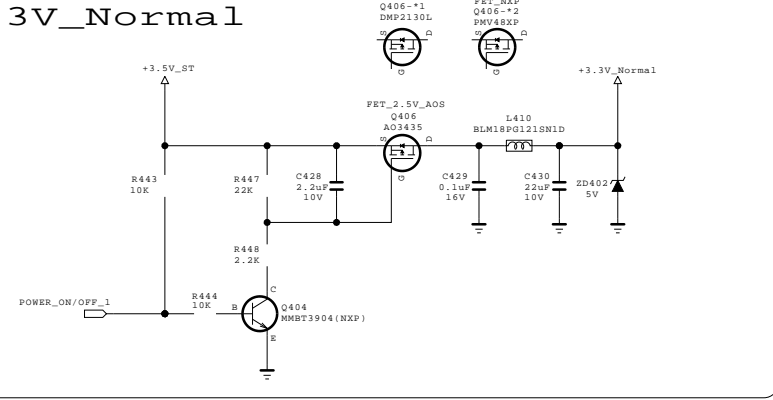

THE  $\Delta$  SYMBOL MARK OF THIS SCHEMATIC DIAGRAM INCORPORATES SPECIAL FEATURES IMPORTANT FOR PROTECTION FROM X-RADIATION. FIRE AND ELECTRICAL SHOCK HAZARDS, WHEN SERVICING IF IS ESSENTIAL THAT ONLY MANUFACTURERS SPECIFIED PARTS BE USED FOR THE CRITICAL COMPONENTS IN THE  $\Delta$  SYMBOL MARK OF THE SCHEMATIC.

**SECRET**  
LGElectronics



MODEL	L14_M1A	DATE	131123
BLOCK	Power_PD2	SHEET	4

# USB (SIDE)

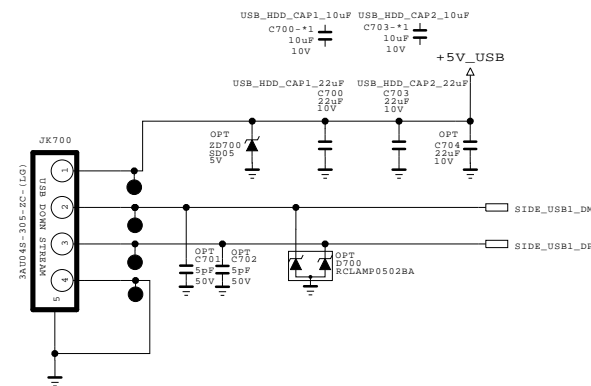

THE SYMBOL MARK OF THIS SCHEMATIC DIAGRAM INCORPORATES SPECIAL FEATURES IMPORTANT FOR PROTECTION FROM X-RADIATION. FIRE AND ELECTRICAL SHOCK HAZARDS, WHEN SERVICING IF IS ESSENTIAL THAT ONLY MANUFACTURERS SPECIFIED PARTS BE USED FOR THE CRITICAL COMPONENTS IN THE SYMBOL MARK OF THE SCHEMATIC.

SECRET  
 LGElectronics

LG ELECTRONICS

MODEL	L14_M1A	DATE	14/03/03
BLOCK	USB_S1	SHEET	7 /

# HDMI (REAR 1 / SIDE 1 MHL)

## HDMI\_1

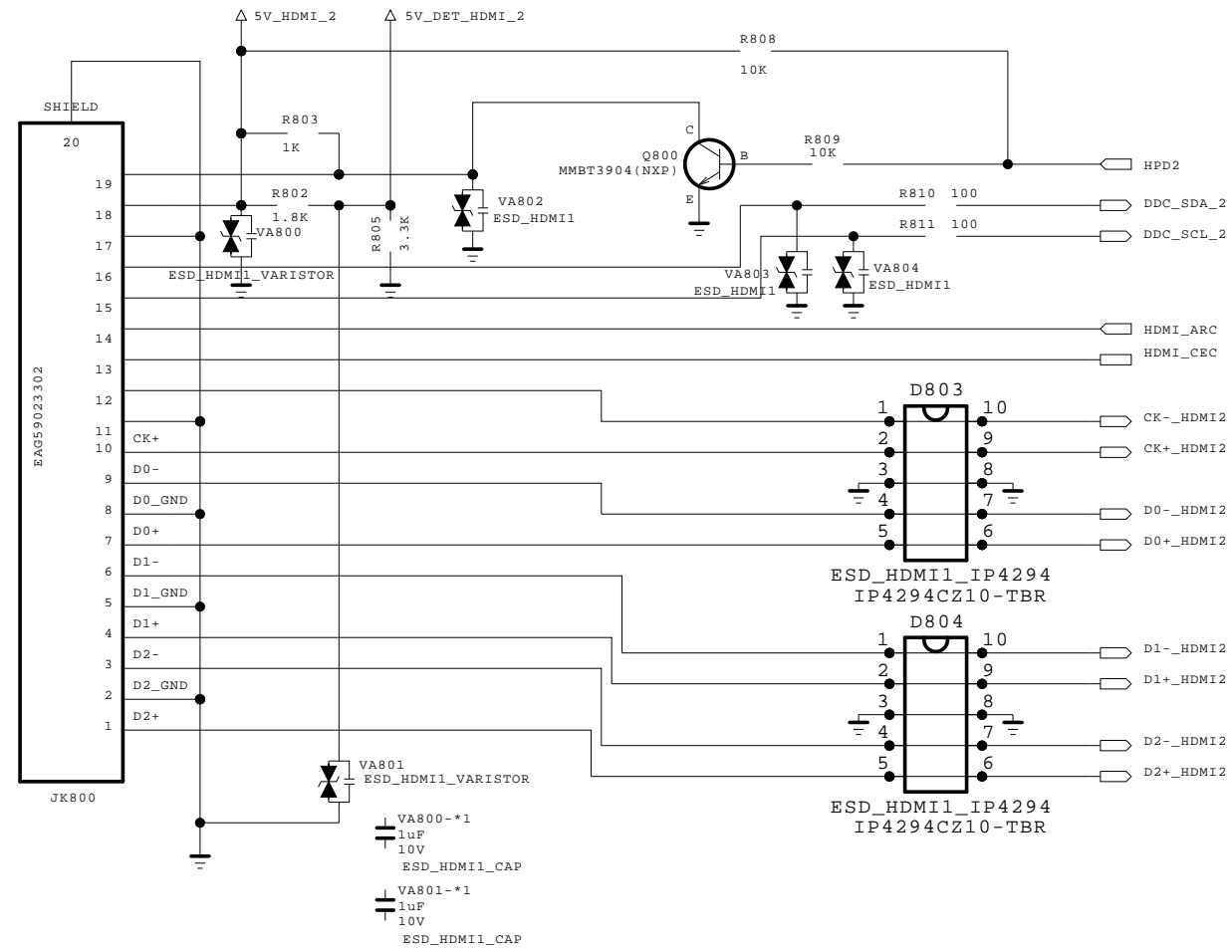

## HDMI\_2 MHL

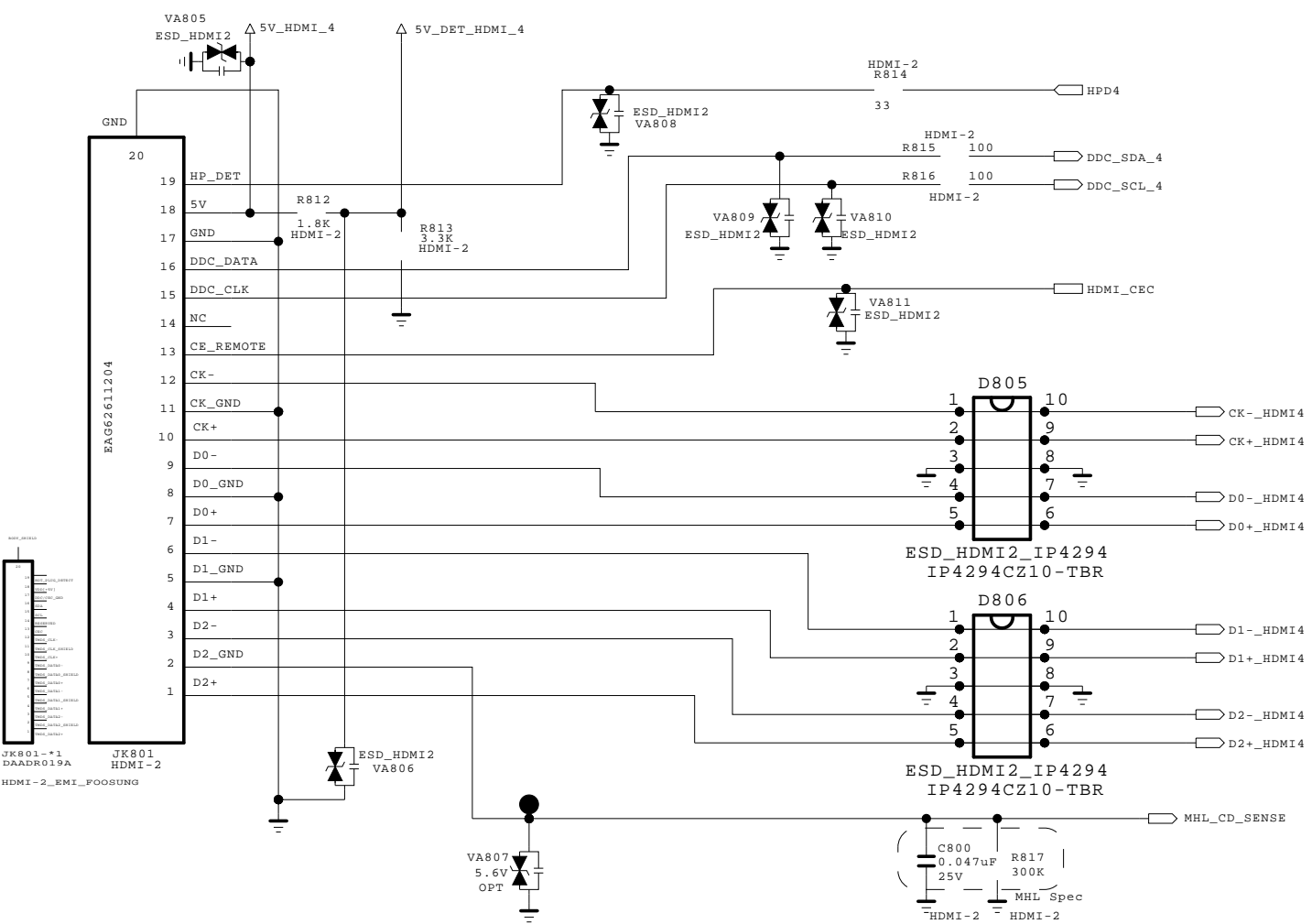

## CEC

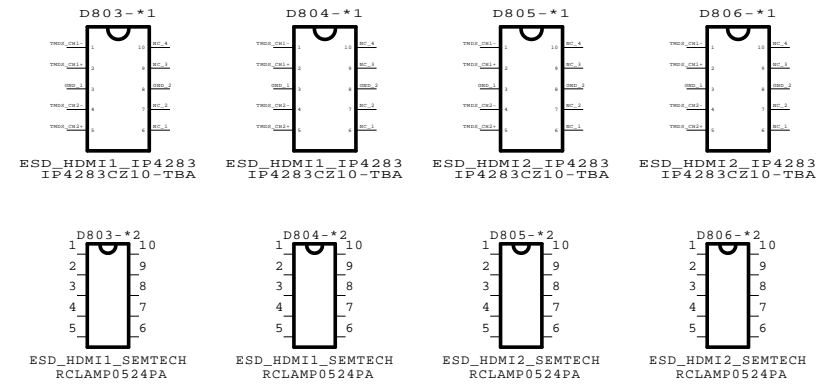
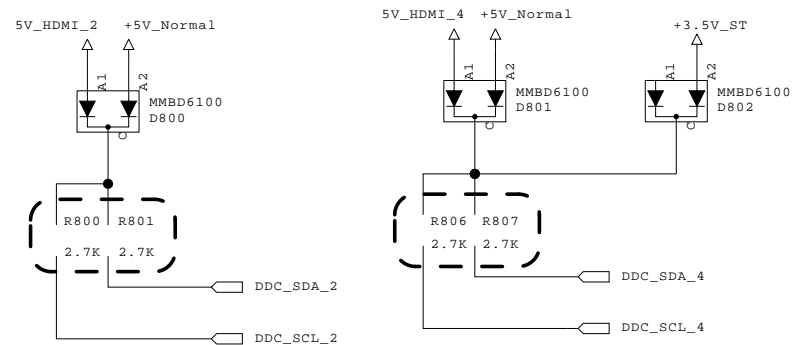

THE ⚠ SYMBOL MARK OF THIS SCHEMATIC DIAGRAM INCORPORATES SPECIAL FEATURES IMPORTANT FOR PROTECTION FROM X-RADIATION. FIRE AND ELECTRICAL SHOCK HAZARDS, WHEN SERVICING IF IS ESSENTIAL THAT ONLY MANUFACTURERS SPECIFIED PARTS BE USED FOR THE CRITICAL COMPONENTS IN THE ⚠ SYMBOL MARK OF THE SCHEMATIC.

**SECRET**  
LGElectronics



MODEL	L14_M1A	DATE	2013/08/15
BLOCK	HDMI_R1_S1	SHEET	8 /

# SPDIF

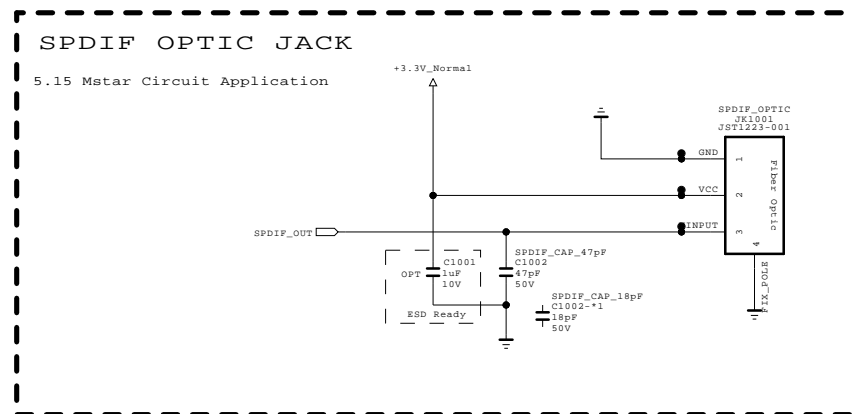

THE SYMBOL MARK OF THIS SCHEMATIC DIAGRAM INCORPORATES SPECIAL FEATURES IMPORTANT FOR PROTECTION FROM X-RADIATION. FIRE AND ELECTRICAL SHOCK HAZARDS, WHEN SERVICING IF IS ESSENTIAL THAT ONLY MANUFACTURERS SPECIFIED PARTS BE USED FOR THE CRITICAL COMPONENTS IN THE SYMBOL MARK OF THE SCHEMATIC.

SECRET  
LGElectronics

LG ELECTRONICS

MODEL	NC5_L14	DATE	2013/10/29
BLOCK	SPDIF	SHEET	10 /

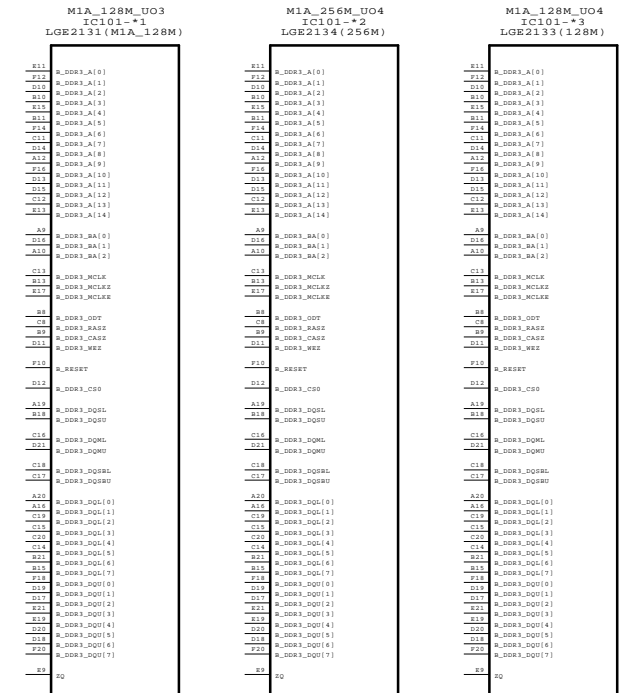
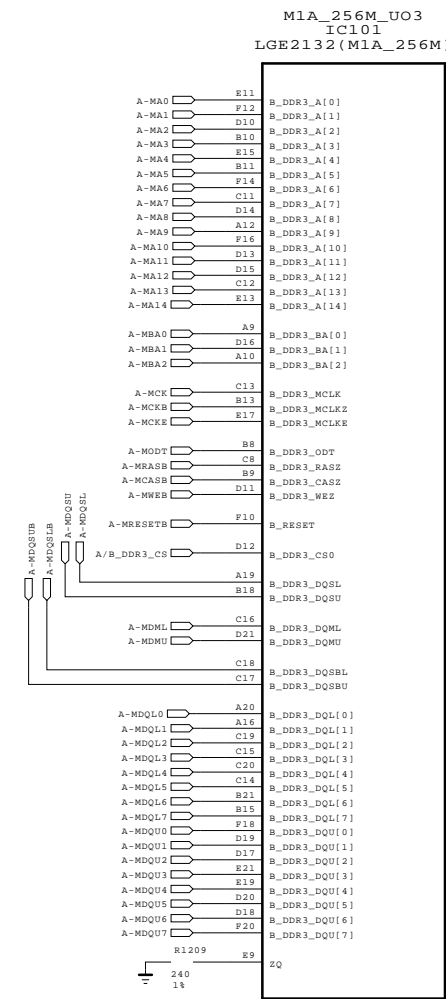
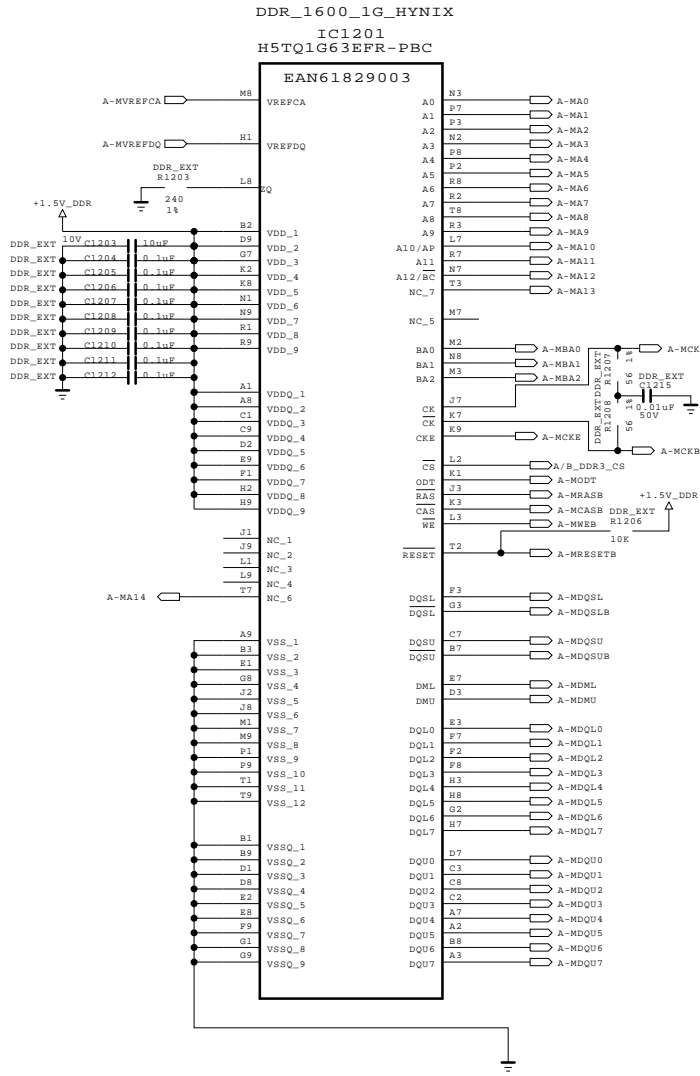
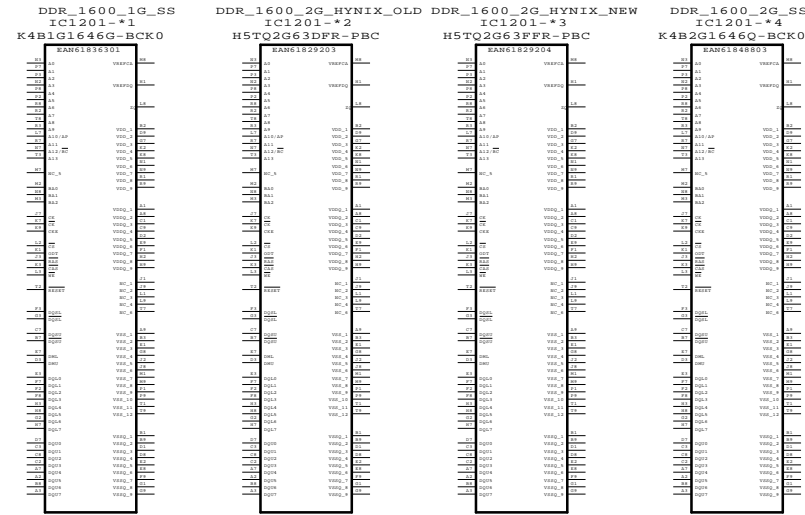
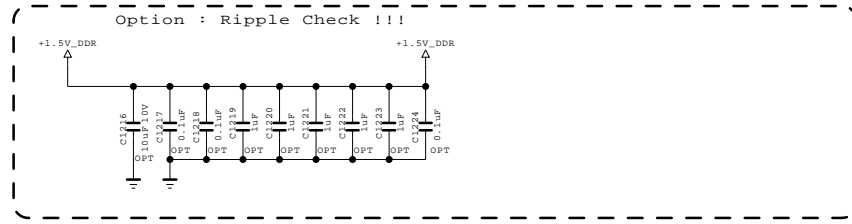
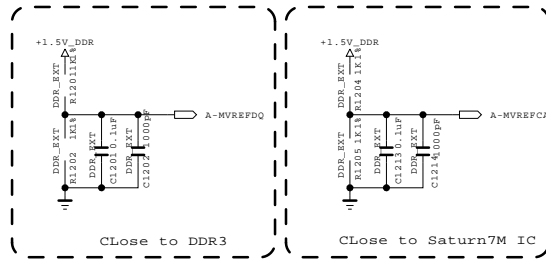

THE  $\Delta$  SYMBOL MARK OF THIS SCHEMATIC DIAGRAM INCORPORATES SPECIAL FEATURES IMPORTANT FOR PROTECTION FROM X-RADIATION. FIRE AND ELECTRICAL SHOCK HAZARDS, WHEN SERVICING IT IS ESSENTIAL THAT ONLY MANUFACTURERS SPECIFIED PARTS BE USED FOR THE CRITICAL COMPONENTS IN THE  $\Delta$  SYMBOL MARK OF THE SCHEMATIC.

SECRET  
LGElectronics



MODEL	NC5_S7LR(M1A)	DATE	2014/02/04
BLOCK	1_DDR	SHEET	12

# Serial Flash for SPI boot

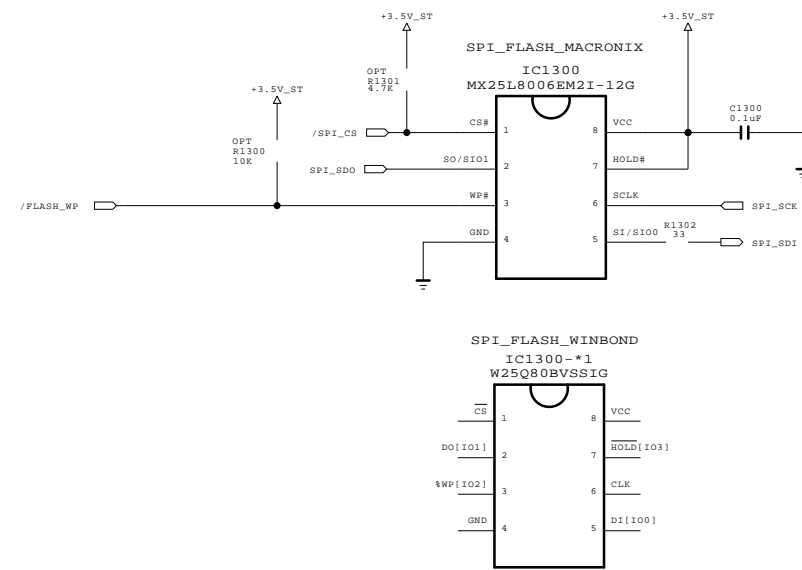

THE SYMBOL MARK OF THIS SCHEMATIC DIAGRAM INCORPORATES SPECIAL FEATURES IMPORTANT FOR PROTECTION FROM X-RADIATION. FIRE AND ELECTRICAL SHOCK HAZARDS, WHEN SERVICING IF IS ESSENTIAL THAT ONLY MANUFACTURES SPECIFIED PARTS BE USED FOR THE CRITICAL COMPONENTS IN THE SYMBOL MARK OF THE SCHEMATIC.

**SECRET**  
LGElectronics



MODEL	NC5_S7LR(M1A)	DATE	2013/04/29
BLOCK	S_FLASH	SHEET	13 /

# LVDS\_EU

[51Pin LVDS Connector]  
(For FHD 60Hz)

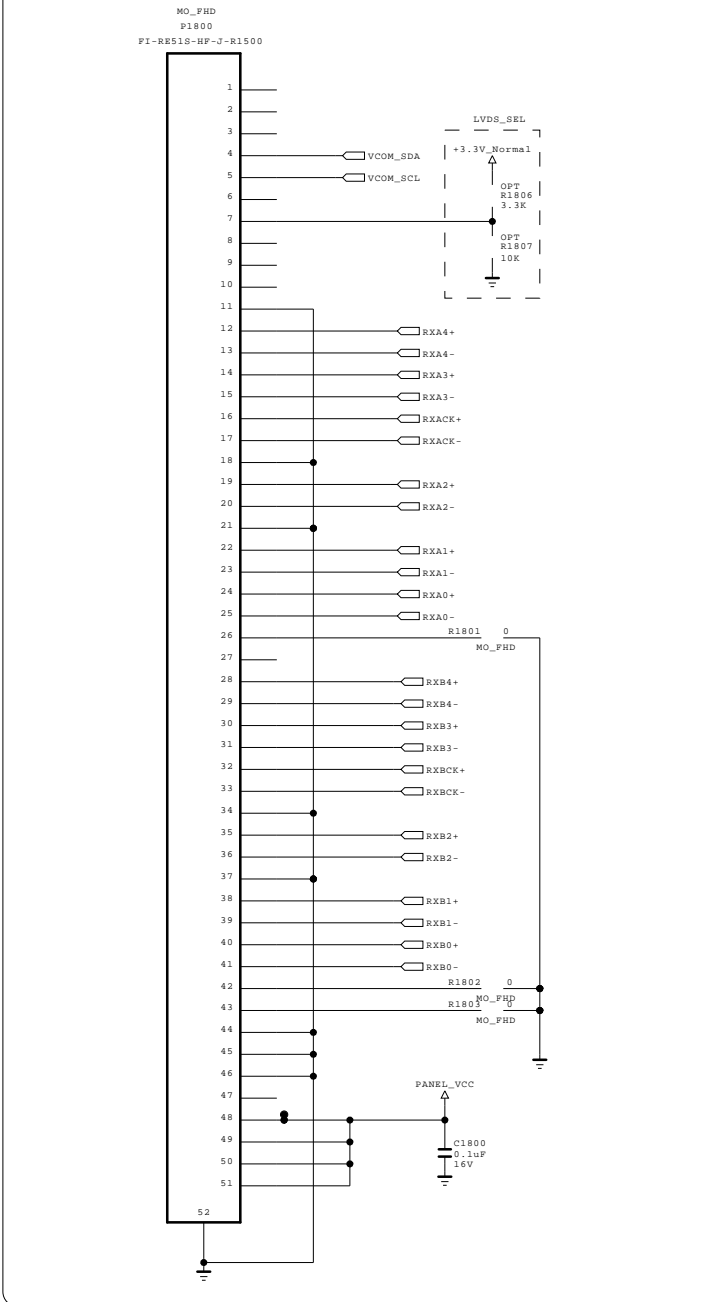

FOR FHD REVERSE(10bit)  
Change in S7LR

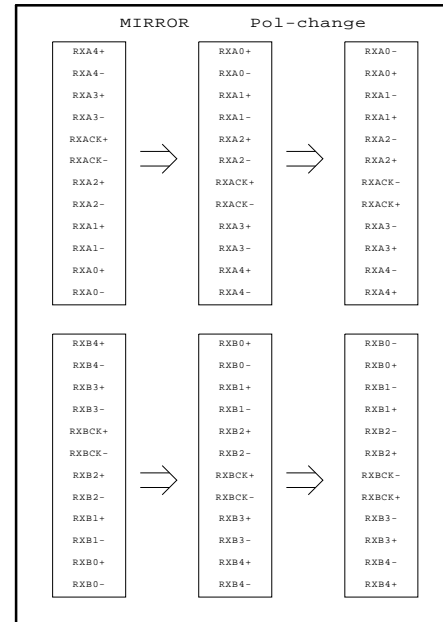

FOR FHD REVERSE(8bit)  
Change in S7LR

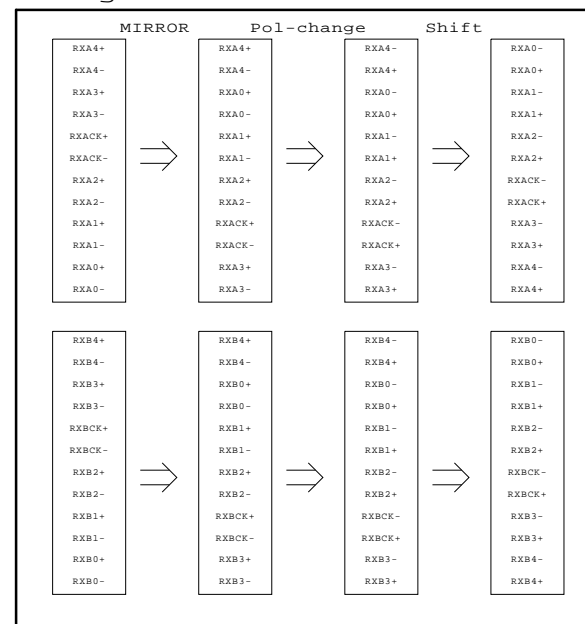

[30Pin LVDS Connector]  
(For HD 60Hz\_Normal)

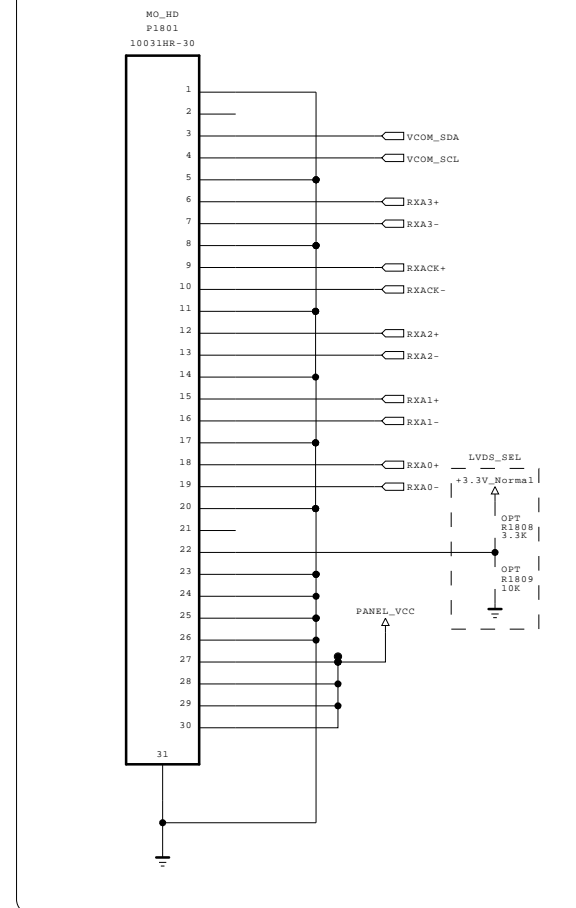

EU pin assign is different from NON EU.  
Because of position of HD wafer.

V-COM I2C

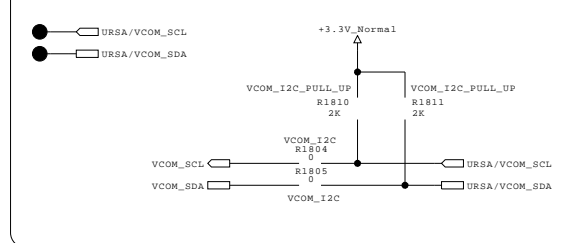

THE  $\Delta$  SYMBOL MARK OF THIS SCHEMATIC DIAGRAM INCORPORATES SPECIAL FEATURES IMPORTANT FOR PROTECTION FROM X-RADIATION. FIRE AND ELECTRICAL SHOCK HAZARDS, WHEN SERVICING IT IS ESSENTIAL THAT ONLY MANUFACTURERS SPECIFIED PARTS BE USED FOR THE CRITICAL COMPONENTS IN THE  $\Delta$  SYMBOL MARK OF THE SCHEMATIC.

SECRET  
LGElectronics

LG ELECTRONICS

MODEL	L14_M1A	DATE	2013.07.15
BLOCK	LVDS_EU	SHEET	18 /

# CI Region

\* Option name of this page : CI\_SLOT  
(because of Hong Kong)

## CI SLOT

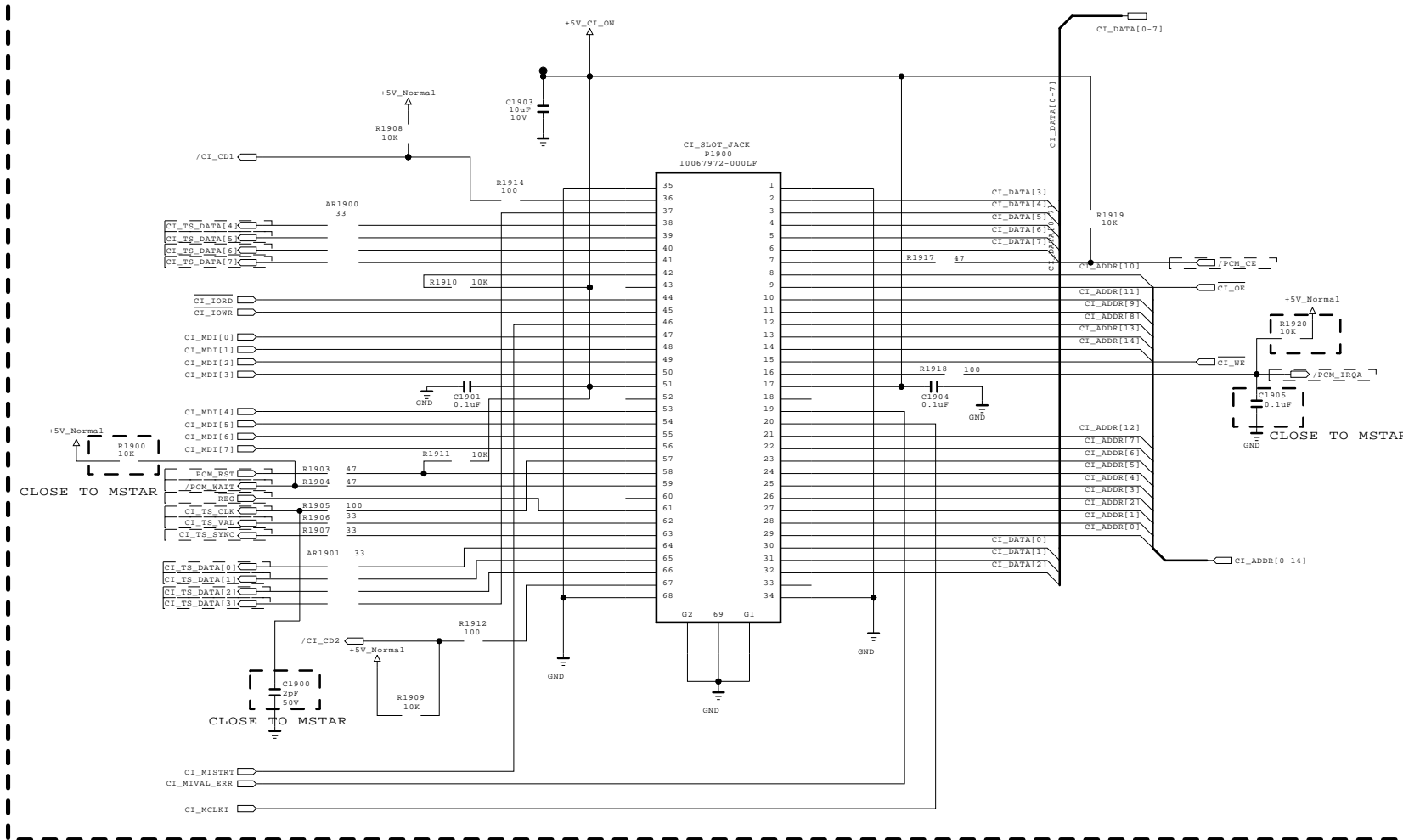

## CI TS INPUT

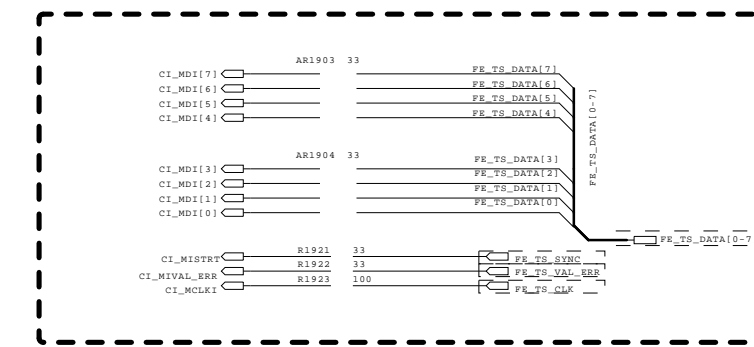

## CI HOST I/F

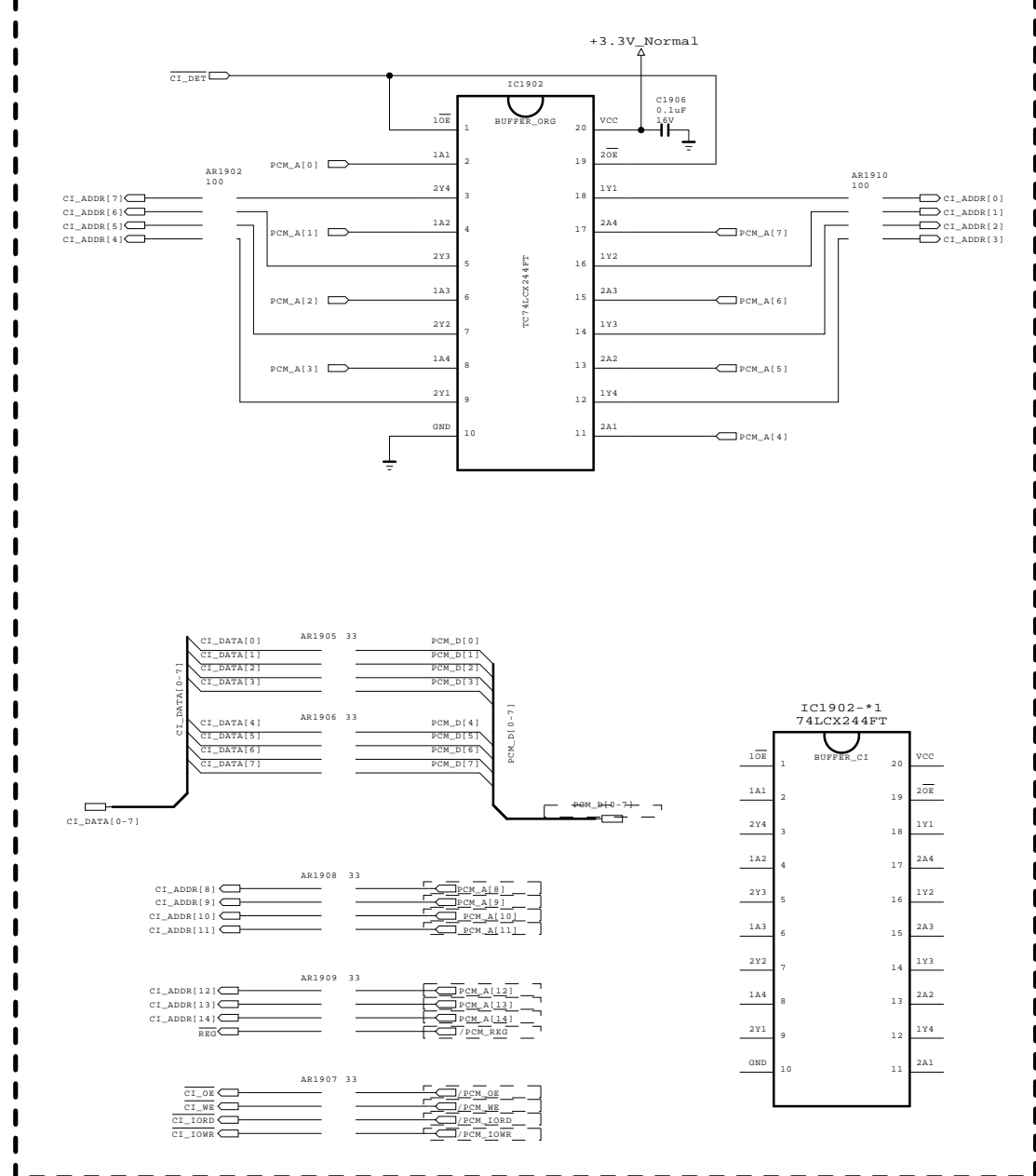

## CI DETECT

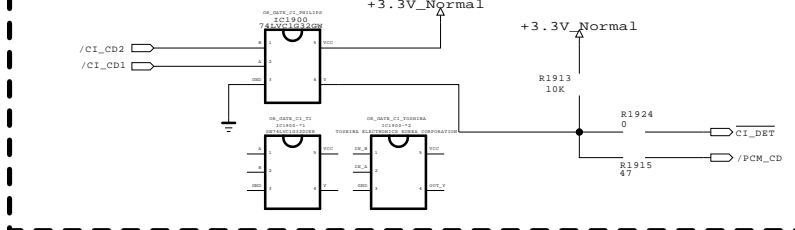

## CI POWER ENABLE CONTROL

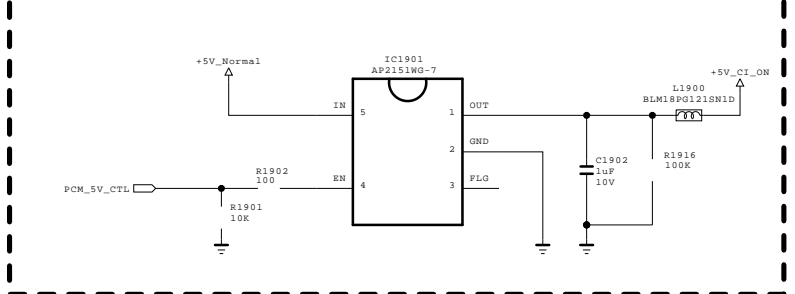

THE  $\Delta$  SYMBOL MARK OF THIS SCHEMATIC DIAGRAM INCORPORATES SPECIAL FEATURES IMPORTANT FOR PROTECTION FROM X-RADIATION. FIRE AND ELECTRICAL SHOCK HAZARDS, WHEN SERVICING IT IS ESSENTIAL THAT ONLY MANUFACTURERS SPECIFIED PARTS BE USED FOR THE CRITICAL COMPONENTS IN THE  $\Delta$  SYMBOL MARK OF THE SCHEMATIC.

SECRET  
LGElectronics



MODEL	NC5_M1A	DATE	2013.04.29
BLOCK	PCMCI	SHEET	19



# ETHERNET

\* H/W option : ETHERNET

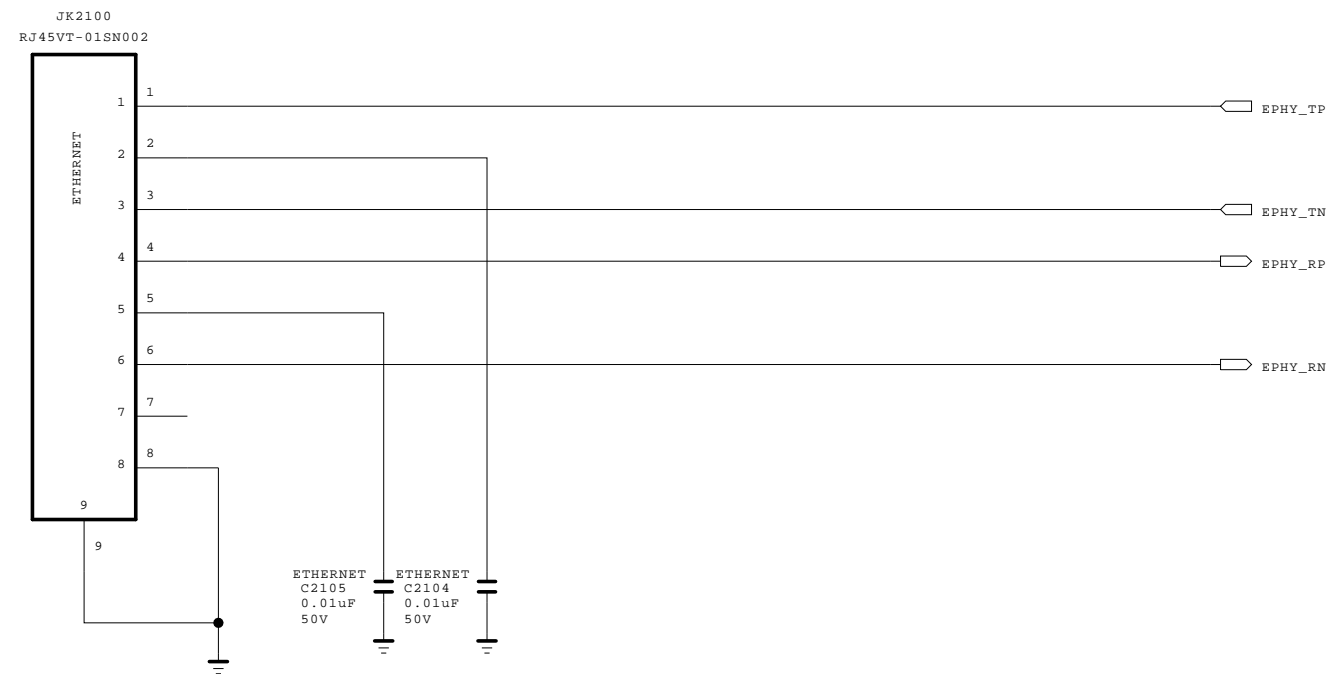

THE SYMBOL MARK OF THIS SCHEMATIC DIAGRAM INCORPORATES SPECIAL FEATURES IMPORTANT FOR PROTECTION FROM X-RADIATION. FIRE AND ELECTRICAL SHOCK HAZARDS, WHEN SERVICING IF IS ESSENTIAL THAT ONLY MANUFACTURERS SPECIFIED PARTS BE USED FOR THE CRITICAL COMPONENTS IN THE SYMBOL MARK OF THE SCHEMATIC.

**SECRET**  
LGElectronics

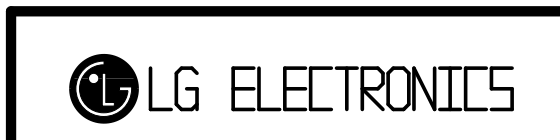

MODEL	NC5_M1A	DATE	2013.04.29
BLOCK	LAN	SHEET	21 /

# DVB-S2 LNB Part Allegro

(Option:LNB)

Input trace widths should be sized to conduct at least 3A  
Output trace widths should be sized to conduct at least 2A

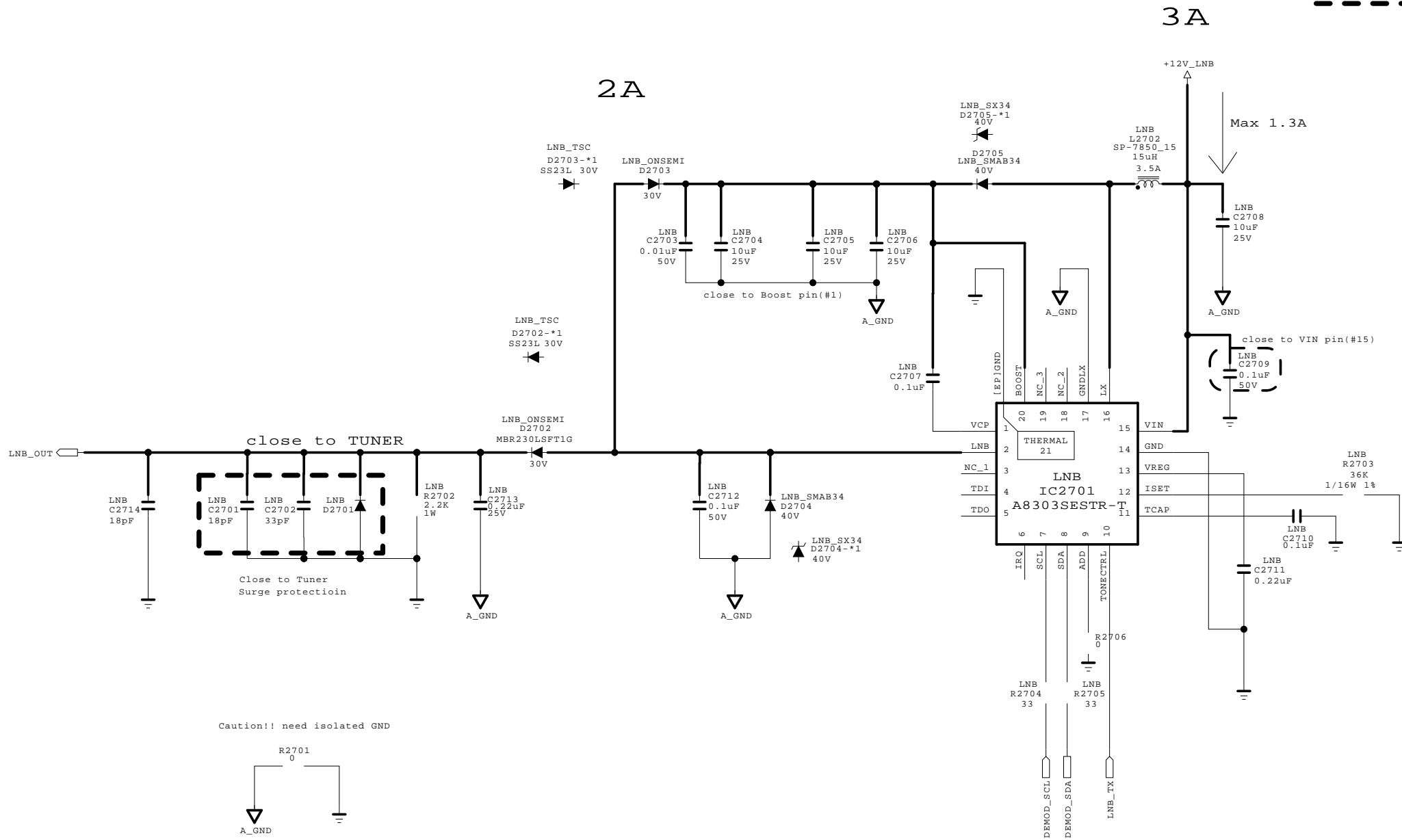

Caution!! need isolated GND

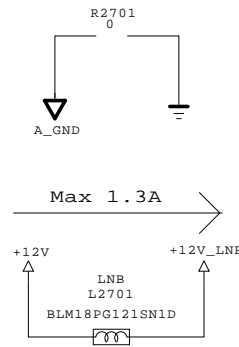

THE ⚠ SYMBOL MARK OF THIS SCHEMATIC DIAGRAM INCORPORATES SPECIAL FEATURES IMPORTANT FOR PROTECTION FROM X-RADIATION. FIRE AND ELECTRICAL SHOCK HAZARDS, WHEN SERVICING IF IS ESSENTIAL THAT ONLY MANUFACTURES SPECIFIED PARTS BE USED FOR THE CRITICAL COMPONENTS IN THE ⚠ SYMBOL MARK OF THE SCHEMATIC.

SECRET	LG ELECTRONICS
LGElectronics	

MODEL	NC5_M1A	DATE	2014.01.24
BLOCK	LNB	SHEET	27 /

# SCART\_COMPONENT

## COMPONENT

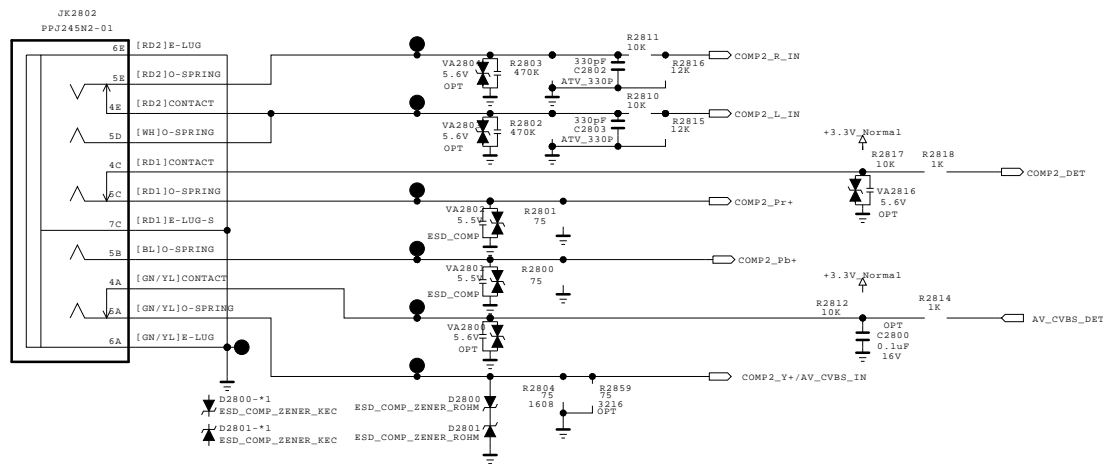

## SCART AMP

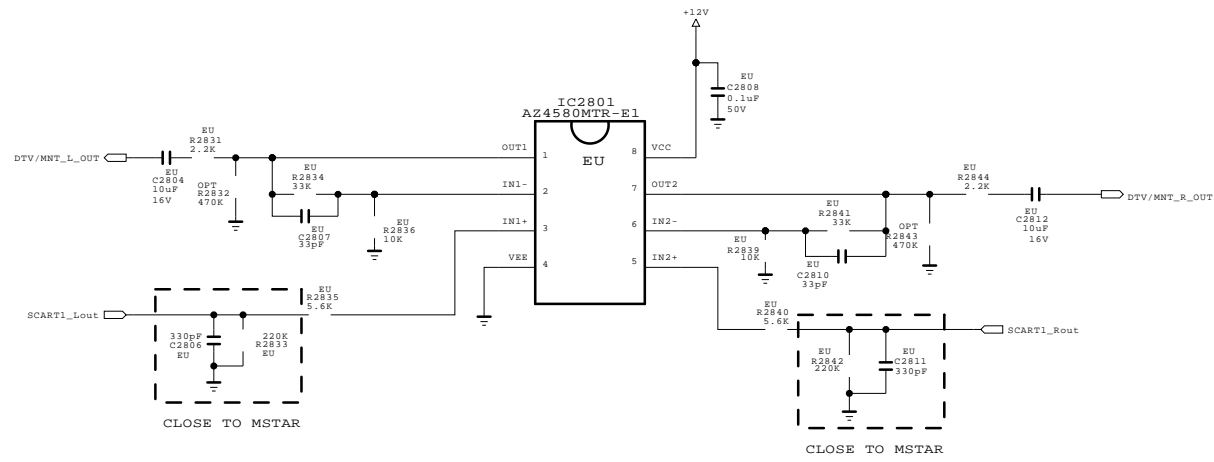

## FULL SCART

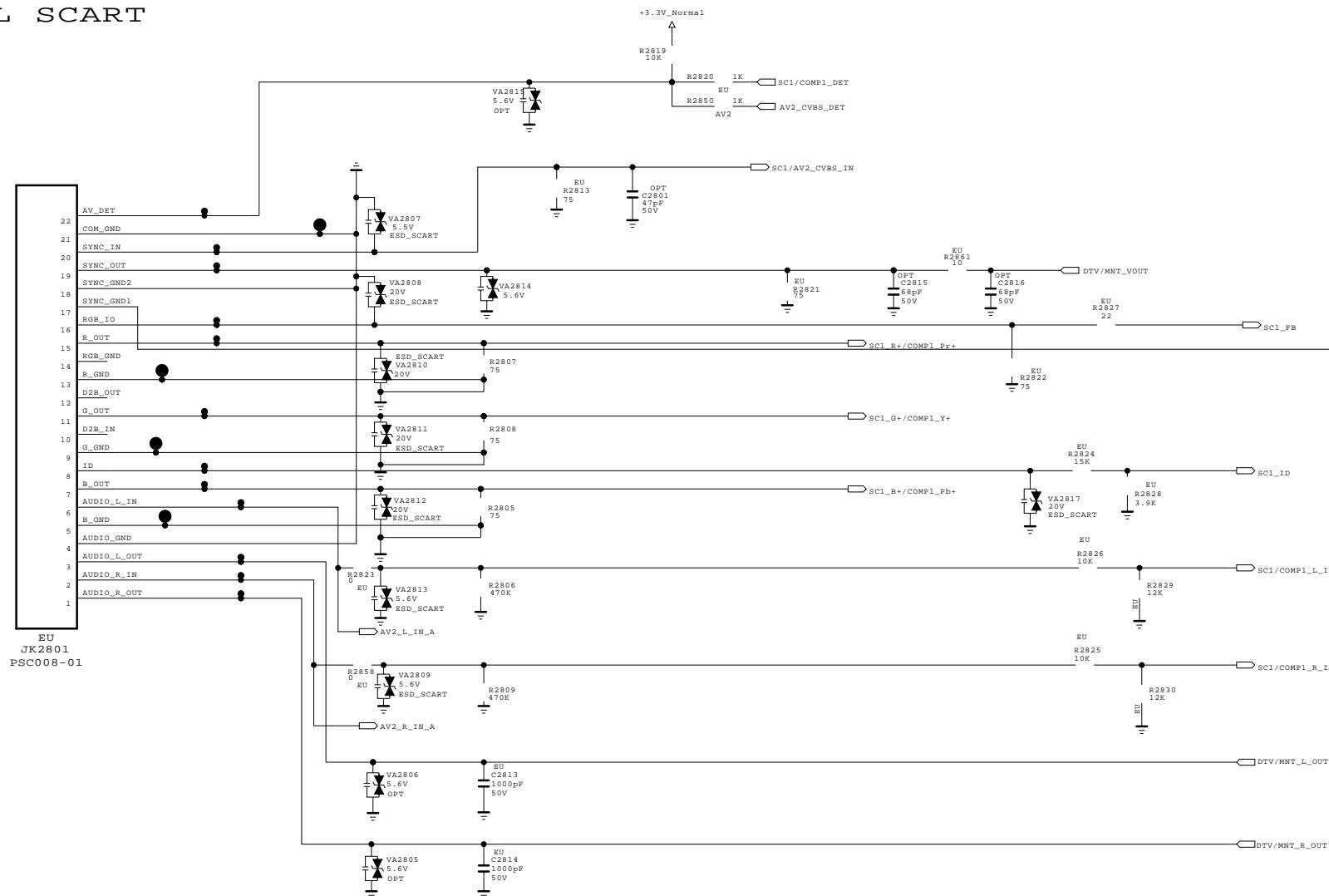

## [ SCART AUDIO MUTE ]

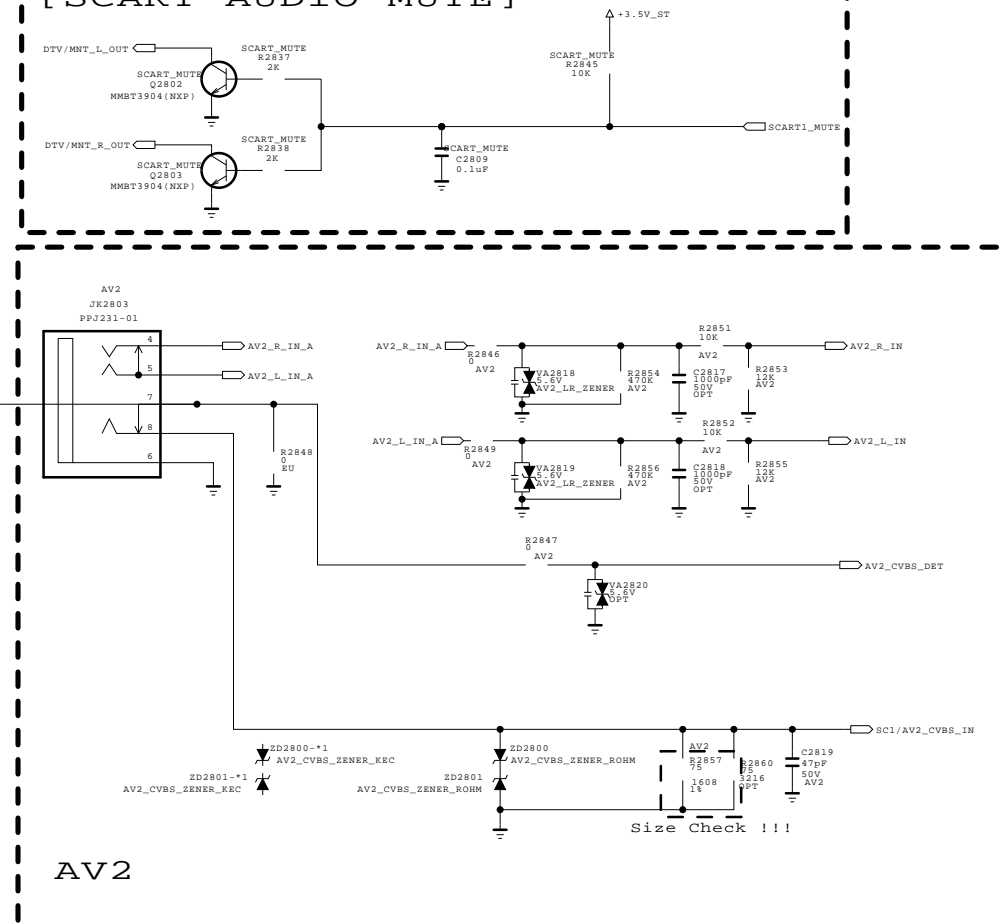

THE  $\Delta$  SYMBOL MARK OF THIS SCHEMATIC DIAGRAM INCORPORATES SPECIAL FEATURES IMPORTANT FOR PROTECTION FROM X-RADIATION. FIRE AND ELECTRICAL SHOCK HAZARDS, WHEN SERVICING IF IS ESSENTIAL THAT ONLY MANUFACTURERS SPECIFIED PARTS BE USED FOR THE CRITICAL COMPONENTS IN THE  $\Delta$  SYMBOL MARK OF THE SCHEMATIC.

**SECRET**  
LGElectronics





MODEL	L14_M1A	DATE	2013.07.24
BLOCK	SCART_COMPONENT	SHEET	28

# Headphone

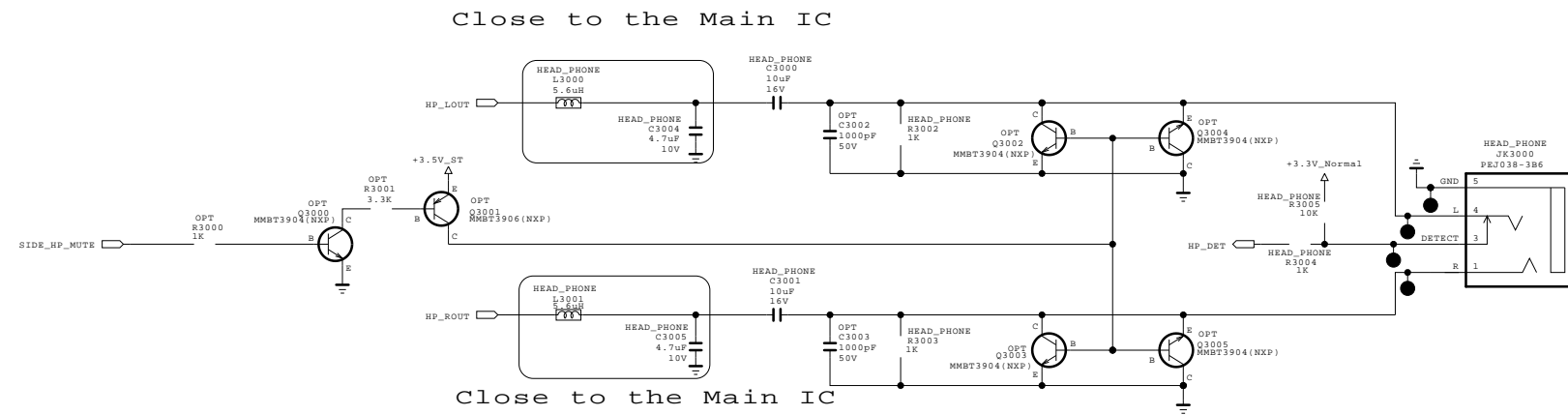
\*Option : HEAD\_PHONE\_EU



THE  SYMBOL MARK OF THIS SCHEMATIC DIAGRAM INCORPORATES SPECIAL FEATURES IMPORTANT FOR PROTECTION FROM X-RADIATION. FIRE AND ELECTRICAL SHOCK HAZARDS, WHEN SERVICING IT IS ESSENTIAL THAT ONLY MANUFACTURERS SPECIFIED PARTS BE USED FOR THE CRITICAL COMPONENTS IN THE  SYMBOL MARK OF THE SCHEMATIC.

SECRET  
LGElectronics



MODEL	NC5_M1A	DATE	2014.01.24
BLOCK	HEAD_PHONE_EU	SHEET	30 /

L14 TUNER\_EU T/C\_T2/C/S2\_CHINA

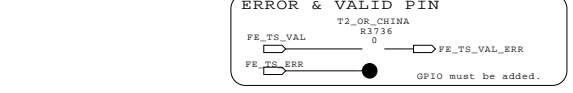
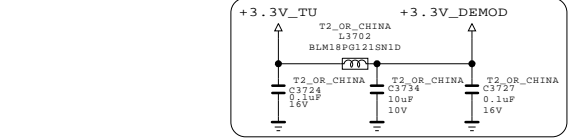
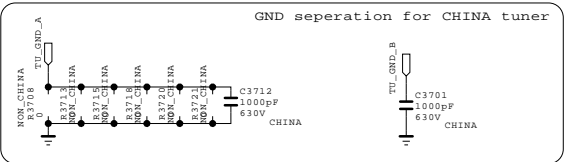
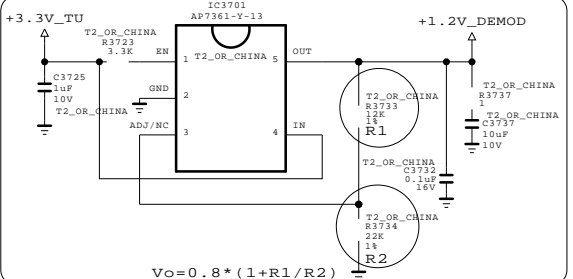
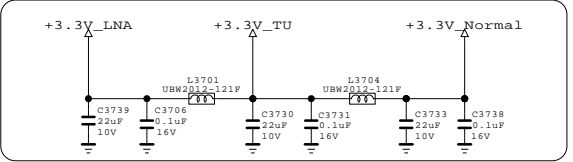
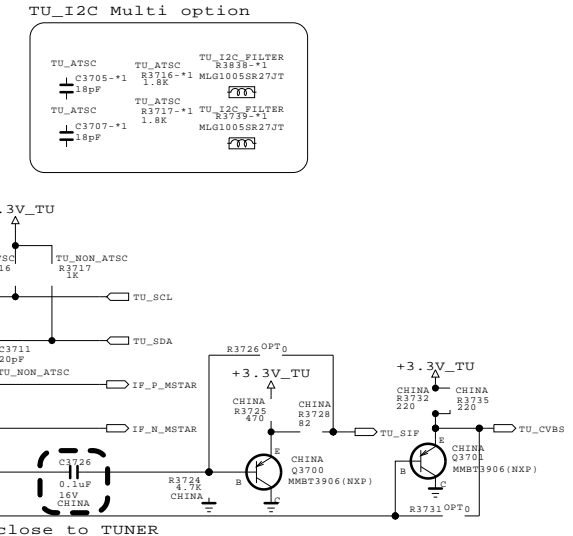
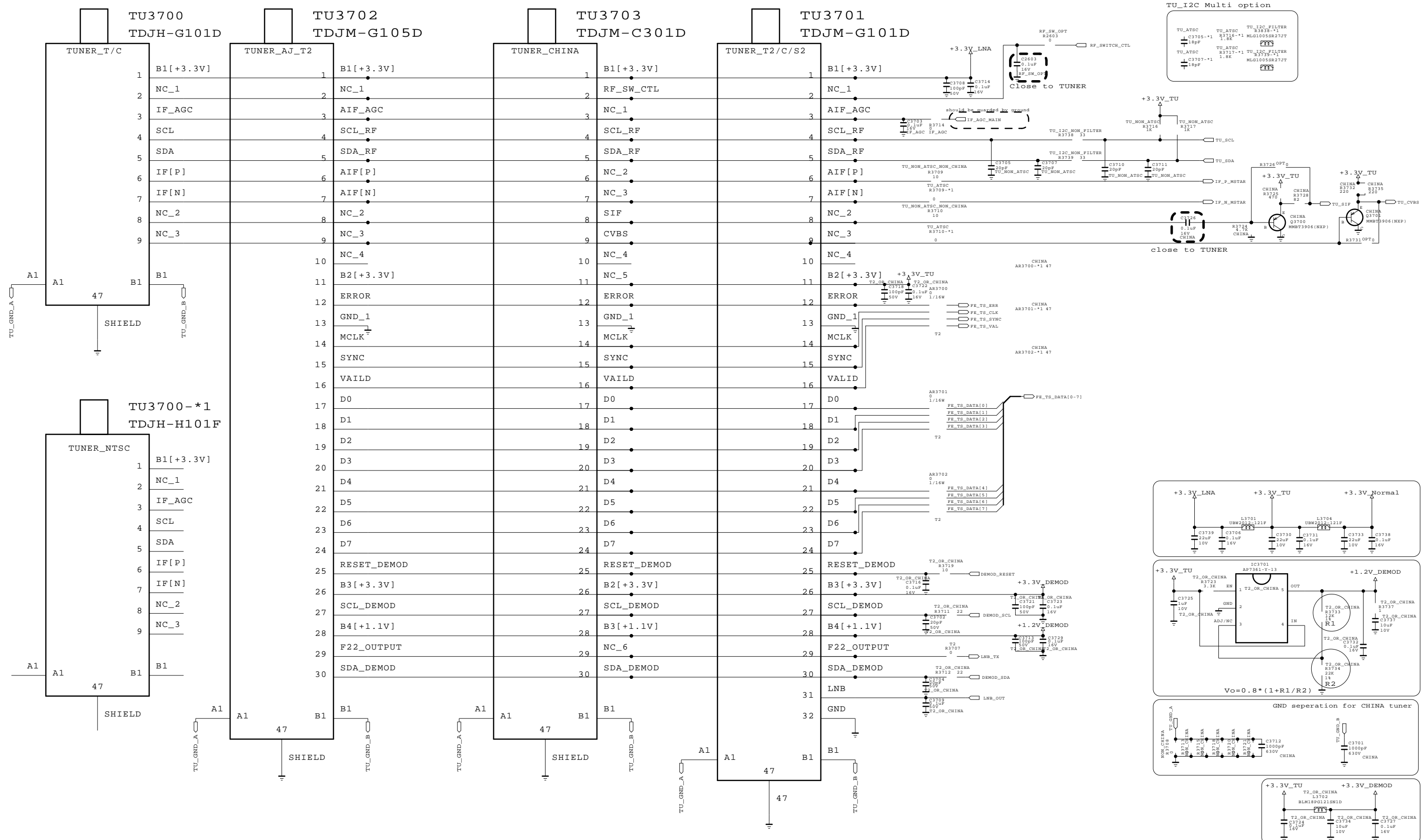

THE  $\Delta$  SYMBOL MARK OF THIS SCHEMATIC DIAGRAM INCORPORATES SPECIAL FEATURES IMPORTANT FOR PROTECTION FROM X-RADIATION. FIRE AND ELECTRICAL SHOCK HAZARDS, WHEN SERVICING IF IS ESSENTIAL THAT ONLY MANUFACTURERS SPECIFIED PARTS BE USED FOR THE CRITICAL COMPONENTS IN THE  $\Delta$  SYMBOL MARK OF THE SCHEMATIC.

**SECRET**  
LGElectronics



MODEL	L14_M1A	DATE	2013.08.27
BLOCK	TUNER_EU	SHEET	37

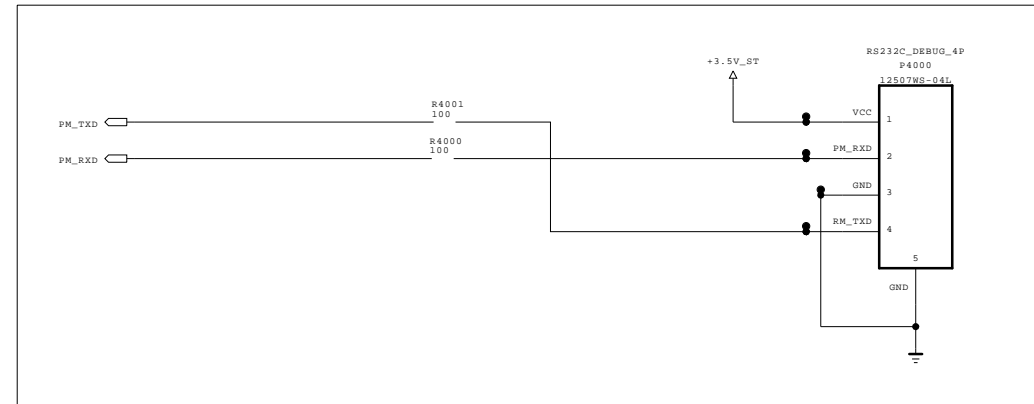

# RS-232C 4PIN & MSTAR DEBUG 4PIN

RS-232C 4PIN

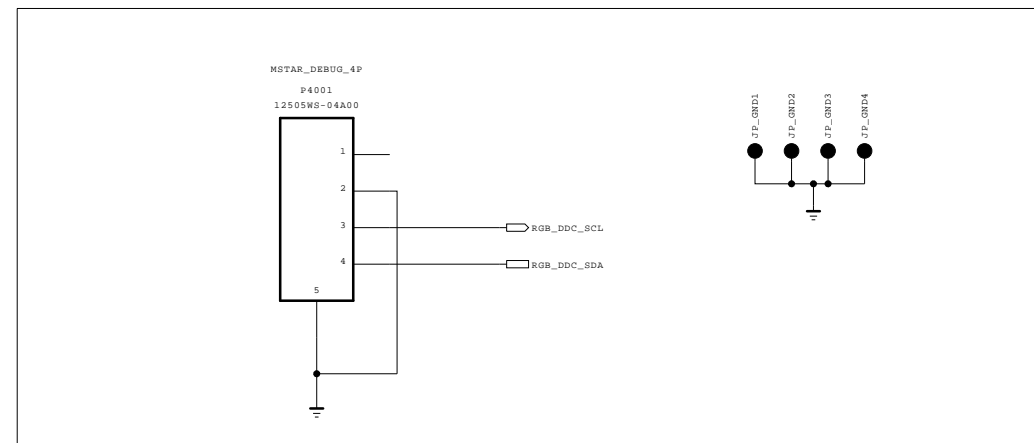

MSTAR DEBUG 4PIN



THE  SYMBOL MARK OF THIS SCHEMATIC DIAGRAM INCORPORATES SPECIAL FEATURES IMPORTANT FOR PROTECTION FROM X-RADIATION. FIRE AND ELECTRICAL SHOCK HAZARDS, WHEN SERVICING IF IS ESSENTIAL THAT ONLY MANUFACTURES SPECIFIED PARTS BE USED FOR THE CRITICAL COMPONENTS IN THE  SYMBOL MARK OF THE SCHEMATIC.

SECRET  
LGElectronics

 LG ELECTRONICS

MODEL	L14_S7LR(M1A)	DATE	2013/04/30
BLOCK	RS232C_MSTAR_DEBUG_4P	SHEET	40 /

# TP for EU

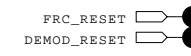
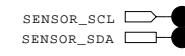
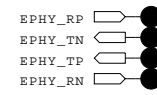
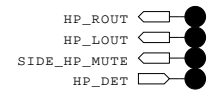
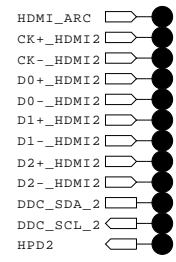
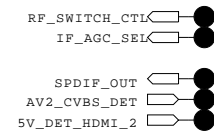

THE ⚠ SYMBOL MARK OF THIS SCHEMATIC DIAGRAM INCORPORATES SPECIAL FEATURES IMPORTANT FOR PROTECTION FROM X-RADIATION. FIRE AND ELECTRICAL SHOCK HAZARDS, WHEN SERVICING IF IS ESSENTIAL THAT ONLY MANUFACTURERS SPECIFIED PARTS BE USED FOR THE CRITICAL COMPONENTS IN THE ⚠ SYMBOL MARK OF THE SCHEMATIC.



SECRET  
LGElectronics

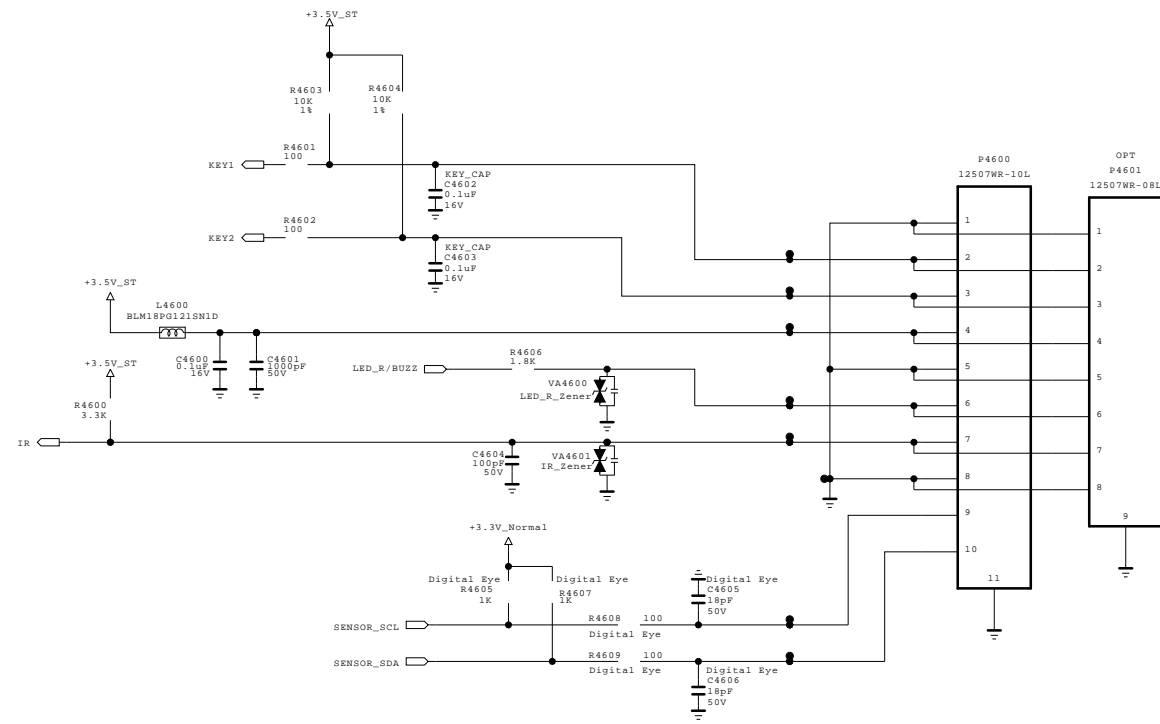

MODEL	NC5_M1A	DATE	2013/04/29
BLOCK	TP_EU	SHEET	41 /

# IR/LED + Digital Eye + Control



THE  SYMBOL MARK OF THIS SCHEMATIC DIAGRAM INCORPORATES SPECIAL FEATURES IMPORTANT FOR PROTECTION FROM X-RADIATION. FIRE AND ELECTRICAL SHOCK HAZARDS, WHEN SERVICING IT IS ESSENTIAL THAT ONLY MANUFACTURERS SPECIFIED PARTS BE USED FOR THE CRITICAL COMPONENTS IN THE  SYMBOL MARK OF THE SCHEMATIC.

**SECRET**  
LGElectronics



MODEL	L14_M1A	DATE	2013/09/03
BLOCK	IR_EYE_SENSOR	SHEET	46 /



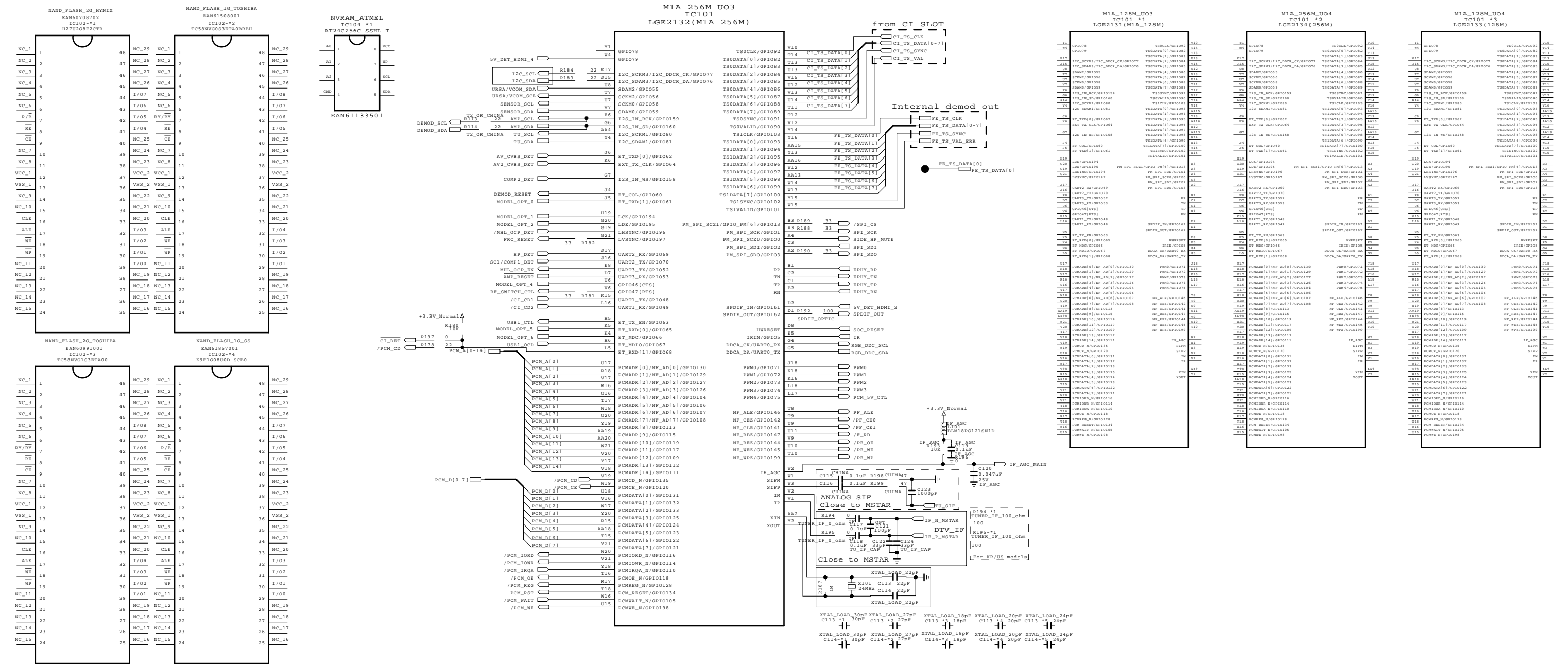
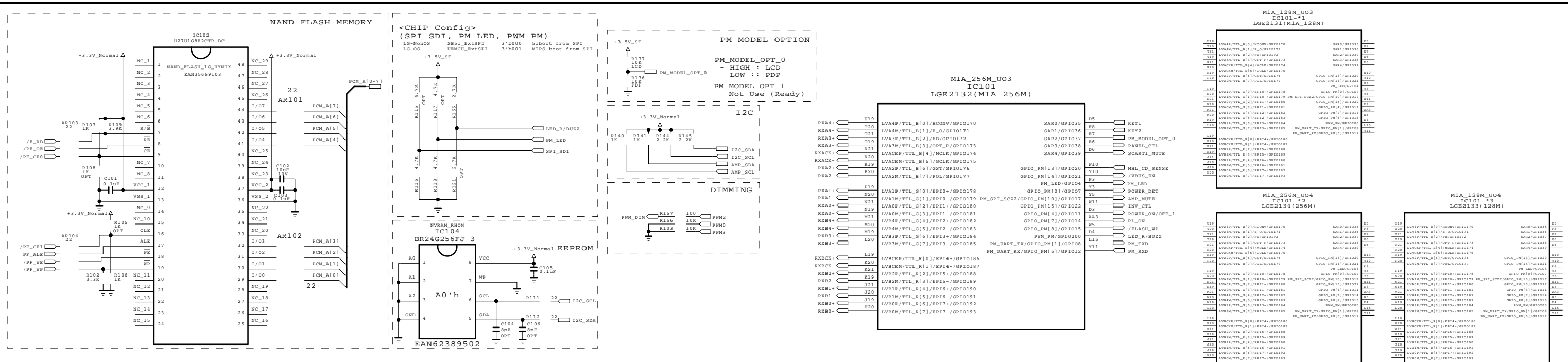

THE  $\Delta$  SYMBOL MARK OF THIS SCHEMATIC DIAGRAM INCORPORATES SPECIAL FEATURES IMPORTANT FOR PROTECTION FROM X-RADIATION. FIRE AND ELECTRICAL SHOCK HAZARDS, WHEN SERVICING IF IS ESSENTIAL THAT ONLY MANUFACTURES SPECIFIED PARTS BE USED FOR THE CRITICAL COMPONENTS IN THE  $\Delta$  SYMBOL MARK OF THE SCHEMATIC.

**SECRET**  
LGElectronics



**MODEL BLOCK** L14\_M1A MAIN1\_EU  
**DATE SHEET** 2014/02/04 1

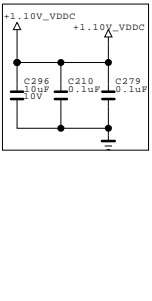
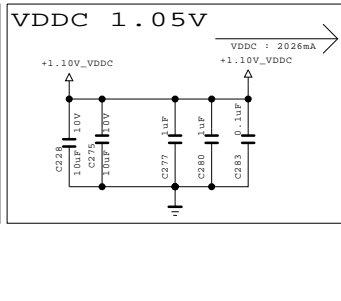
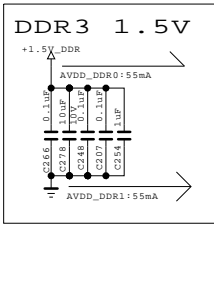
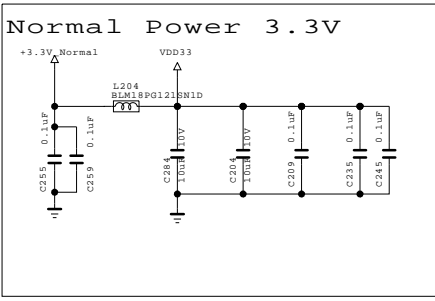
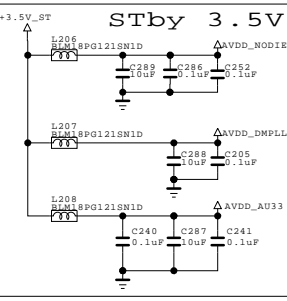
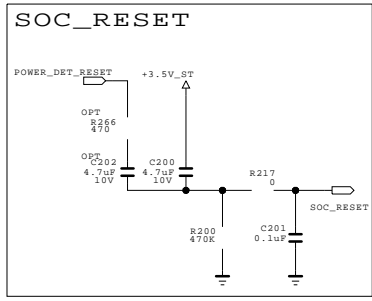
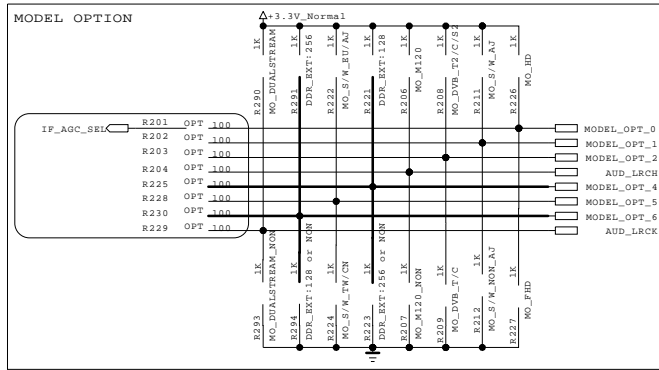

MODEL OPTION		LOW	HIGH
MODEL_OPT_0	J5	MO_FHD	MO_HD
MODEL_OPT_1	H19	MO_S/W_NON_AJ	MO_S/W_AJ
MODEL_OPT_2	G20	MO_DVB_T/C	MO_DVB_T2/C/S2
AUD_LRCH	G19	MO_M120_NON	MO_M120
MODEL_OPT_4	U6	DDR_EXT:256 or NON	DDR_EXT : 128
MODEL_OPT_5	K5	MO_S/W_TW/CN	MO_S/W_EU/AJ
MODEL_OPT_6	K4	DDR_EXT:128 or NON	DDR_EXT : 256
AUD_LRCK	L5	MO_DUALSTREAM_NON	MO_DUALSTREAM

\* Dual Stream is only Korea 3D spec

Memory INT+EXT	Auto Det	MODEL_OPT_4	MODEL_OPT_6
128M Only	0	0	0
256M Only	1	0	0
128M+128M	0	1	0
128M+256M	0	0	1
256M+256M	1	0	1

Country Option

	MODEL_OPT_1	MODEL_OPT_5
TW	0	0
EU	0	1
CN	1	0
AJ	1	1

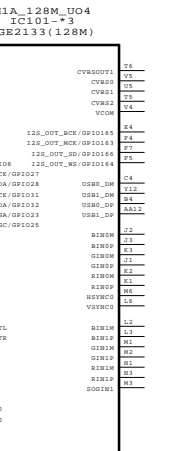
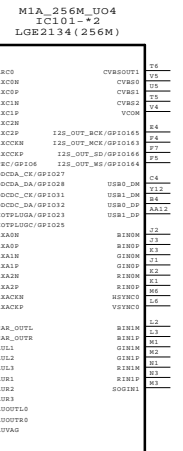
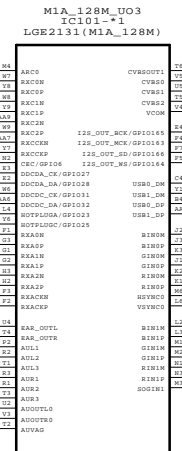

M1A\_256M\_U03 IC101 LGE2132 (M1A\_256M)

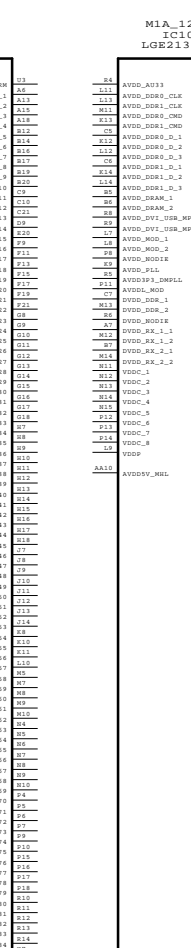
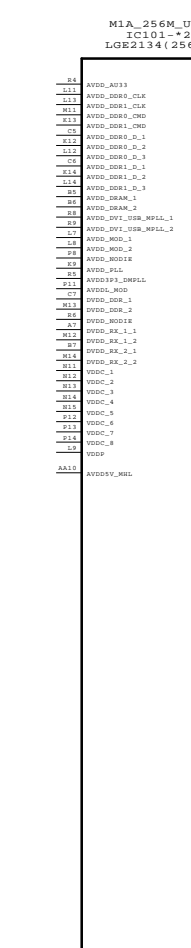
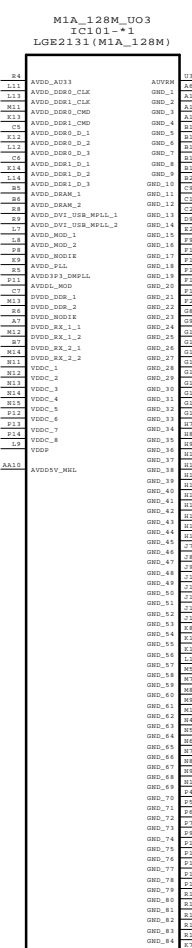
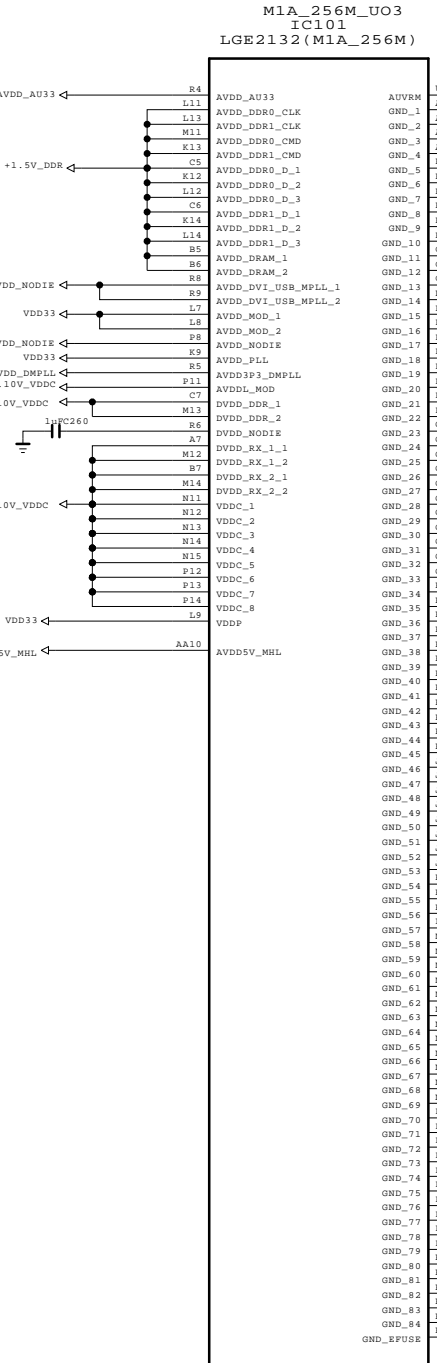
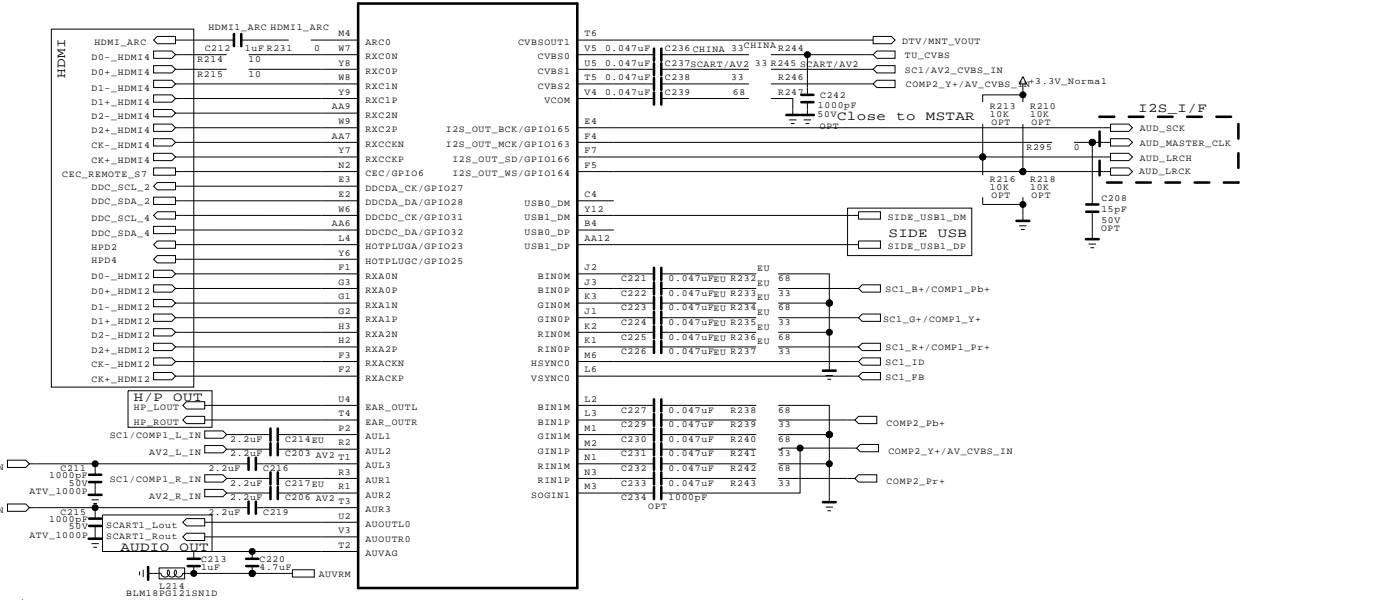

THE  $\Delta$  SYMBOL MARK OF THIS SCHEMATIC DIAGRAM INCORPORATES SPECIAL FEATURES IMPORTANT FOR PROTECTION FROM X-RADIATION. FIRE AND ELECTRICAL SHOCK HAZARDS, WHEN SERVICING IF IS ESSENTIAL THAT ONLY MANUFACTURERS SPECIFIED PARTS BE USED FOR THE CRITICAL COMPONENTS IN THE  $\Delta$  SYMBOL MARK OF THE SCHEMATIC.

SECRET  
LGElectronics



MODEL	L14_M1A	DATE	2014.02.04
BLOCK	MAIN2_EU	SHEET	2

# AUDIO AMP (TI)

This parts are Located on AVSS area.

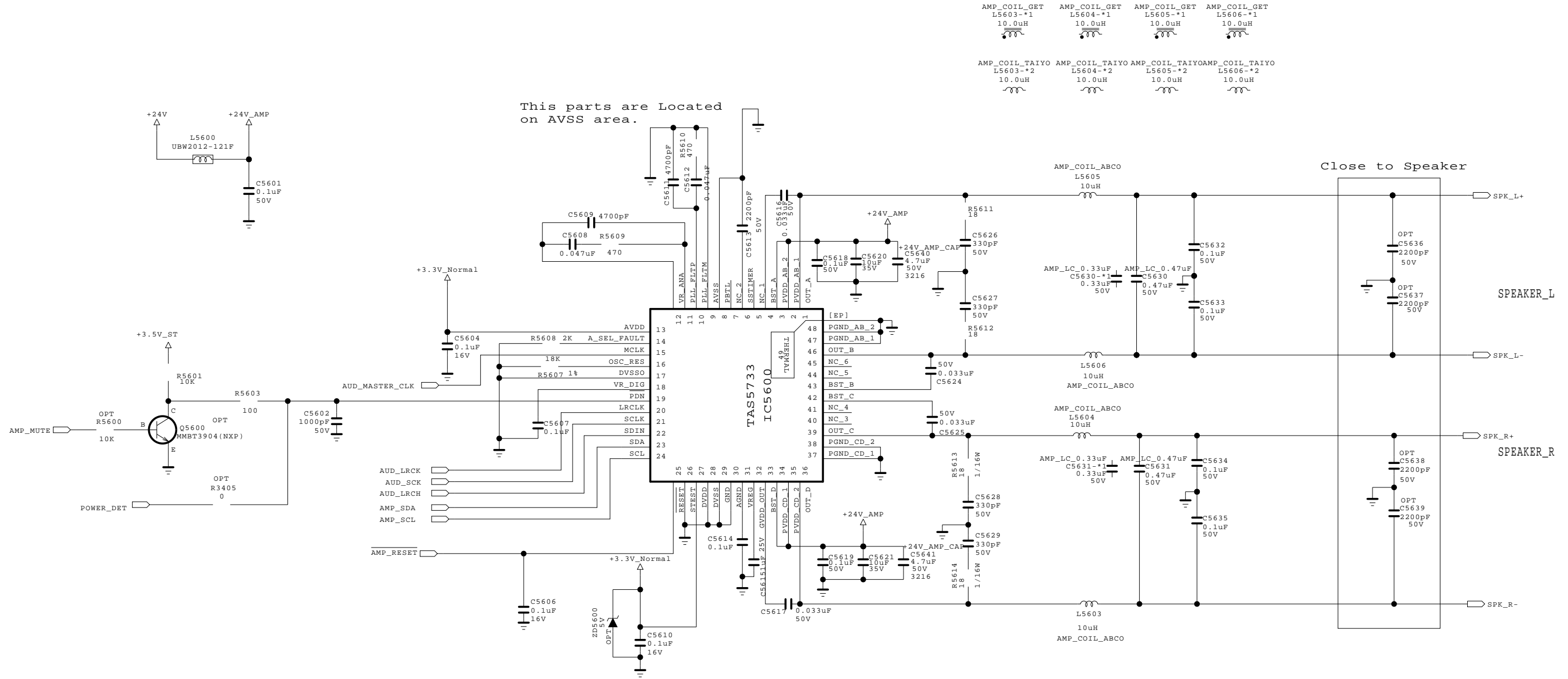

- AMP\_COIL\_GET L5603-\*1 10.0uH
- AMP\_COIL\_GET L5604-\*1 10.0uH
- AMP\_COIL\_GET L5605-\*1 10.0uH
- AMP\_COIL\_GET L5606-\*1 10.0uH
- AMP\_COIL\_TAIYO L5603-\*2 10.0uH
- AMP\_COIL\_TAIYO L5604-\*2 10.0uH
- AMP\_COIL\_TAIYO L5605-\*2 10.0uH
- AMP\_COIL\_TAIYO L5606-\*2 10.0uH

Close to Speaker

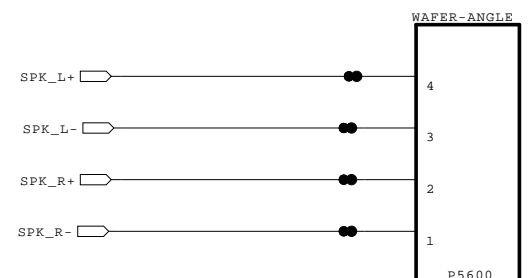

THE ⚠ SYMBOL MARK OF THIS SCHEMATIC DIAGRAM INCORPORATES SPECIAL FEATURES IMPORTANT FOR PROTECTION FROM X-RADIATION. FIRE AND ELECTRICAL SHOCK HAZARDS, WHEN SERVICING IF IS ESSENTIAL THAT ONLY MANUFACTURERS SPECIFIED PARTS BE USED FOR THE CRITICAL COMPONENTS IN THE ⚠ SYMBOL MARK OF THE SCHEMATIC.

**SECRET**  
LGElectronics



MODEL	L14	DATE	131116
BLOCK	AUDIO[TI]	SHEET	56

L14 MHL SW AND GATE

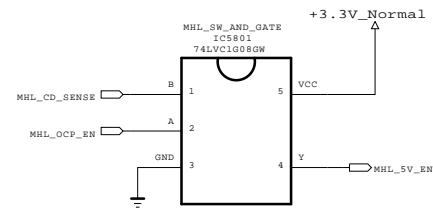

THE SYMBOL MARK OF THIS SCHEMATIC DIAGRAM INCORPORATES SPECIAL FEATURES IMPORTANT FOR PROTECTION FROM X-RADIATION. FIRE AND ELECTRICAL SHOCK HAZARDS, WHEN SERVICING IF IS ESSENTIAL THAT ONLY MANUFACTURERS SPECIFIED PARTS BE USED FOR THE CRITICAL COMPONENTS IN THE SYMBOL MARK OF THE SCHEMATIC.

**SECRET**  
LGElectronics



MODEL	L14_M1A	DATE	2013.09.01
BLOCK	MHL_SW_AND	SHEET	58 /



# L14 Repair Process

## Contents of LCD TV Standard Repair Process

No.	Error symptom (High category)	Error symptom (Mid category)	Page	Remarks
1	A. Video error	No video/Normal audio	1	
2		No video/No audio	2	
3		Tuning fail, Picture broken/ Freezing	3, 4	
4		Color error	5	
5		Vertical/Horizontal bar, residual image, light spot, external device color error	6	
6	B. Power error	No power	7	
7		Off when on, off while viewing, power auto on/off	8	
8	C. Audio error	No audio/Normal video	9	
9		Wrecked audio/discontinuation/noise	10	
10	D. Function error	Remote control & Local switch checking	11	
11		External device recognition error	12	
12	E. Noise	Circuit noise, mechanical noise	13	
13	F. Exterior error	Exterior defect	14	

**\* First of all, Check whether there is SVC Bulletin in GCSC System for these model.**

LCD TV	Error symptom	A. Video error	Established date	2012. 01 .14	
		No video/ Normal audio	Revised date		1/14

**First of all, Check whether all of cables between board is inserted properly or not.  
(Main B/D↔ Power B/D, LVDS Cable, Speaker Cable, IR B/D Cable,,)**

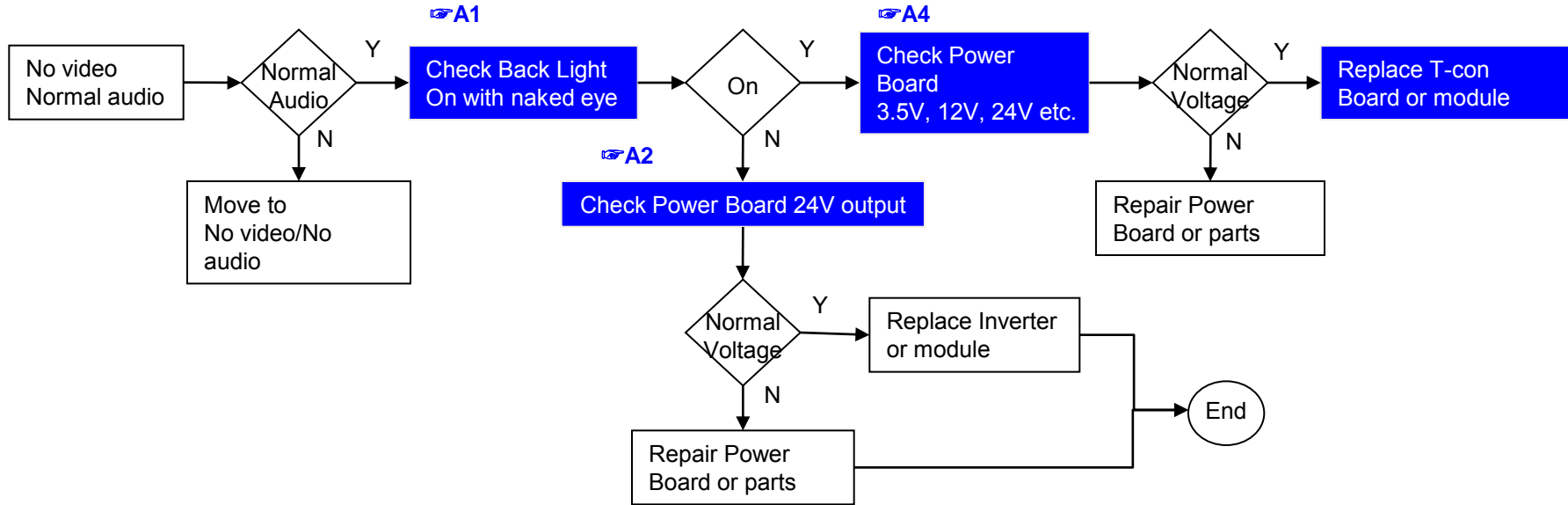

※Precaution A6 & A3

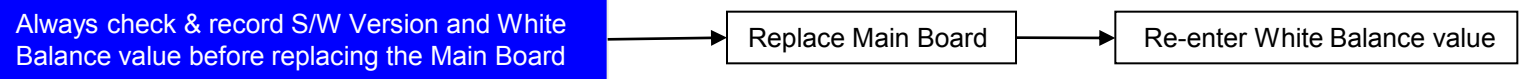



LCD TV	Error symptom	A. Video error	Established date	2012 . 01 .14	
		No video/ No audio	Revised date		2/14

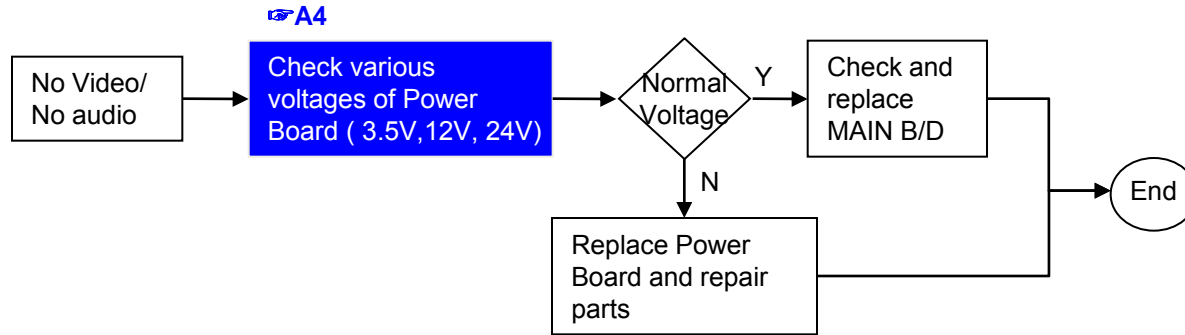

LCD TV	Error symptom	A. Video error	Established date	2012. 01 .14	
		Picture broken/ Freezing	Revised date		3/14

A5

Check RF Signal level

- . By using Digital signal level meter
- . By using Diagnostics menu on OSD ( Menu → Set up → Support → Signal Test )
  - Signal strength (Normal : over 50%)
  - Signal Quality (Normal: over 50%)

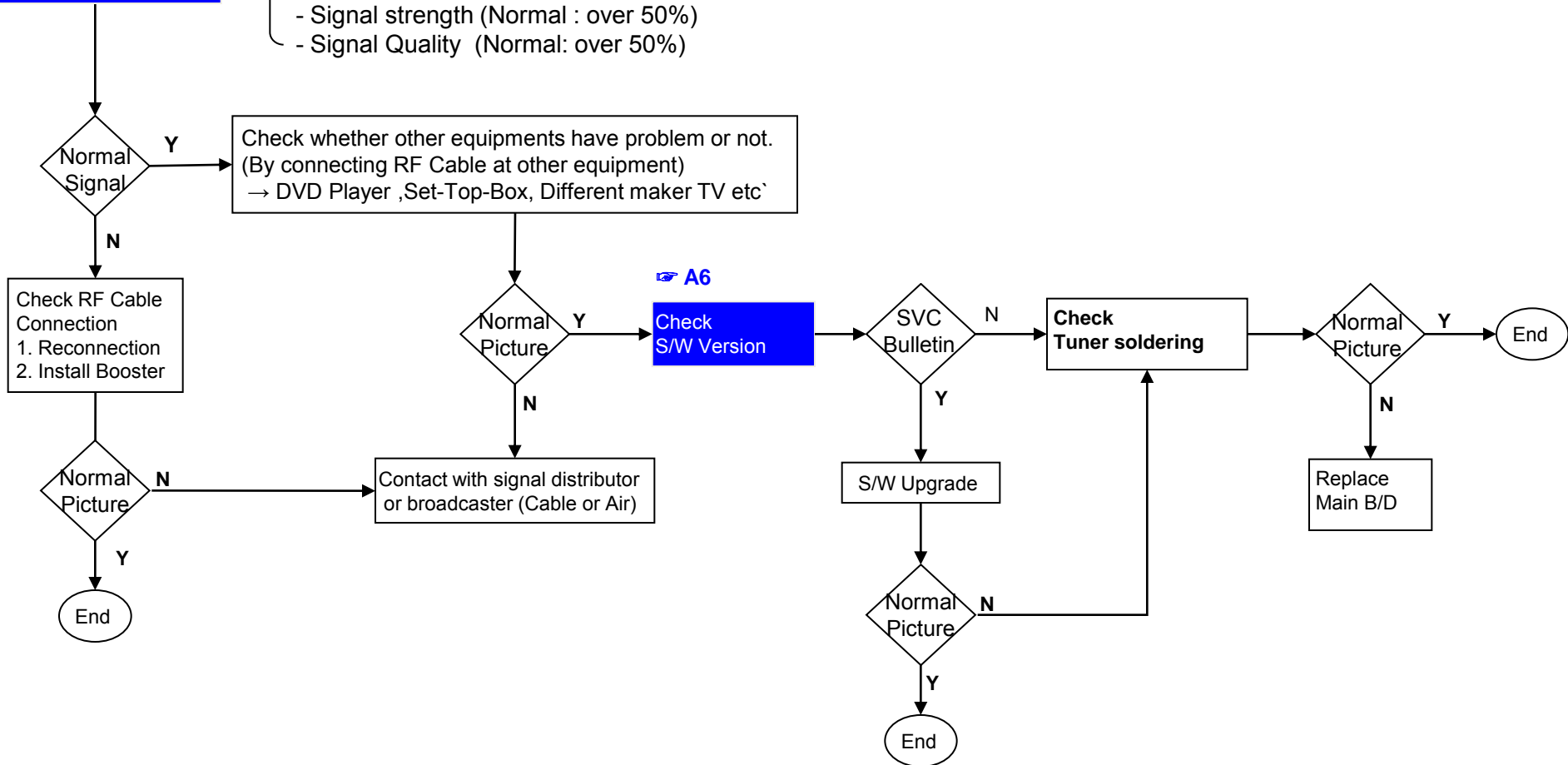

LCD TV	Error symptom	A. Video error	Established date	2012. 01 .14	
		Tuning fail, Picture broken/ Freezing	Revised date		4/14

A5

Check RF Signal level

Check RF signal cable (DVB satellite signal or not)  
 Check whether other equipments have problem or not.  
 (By connecting RF Cable at other equipment)  
 → Set-Top-Box, Different maker TV etc

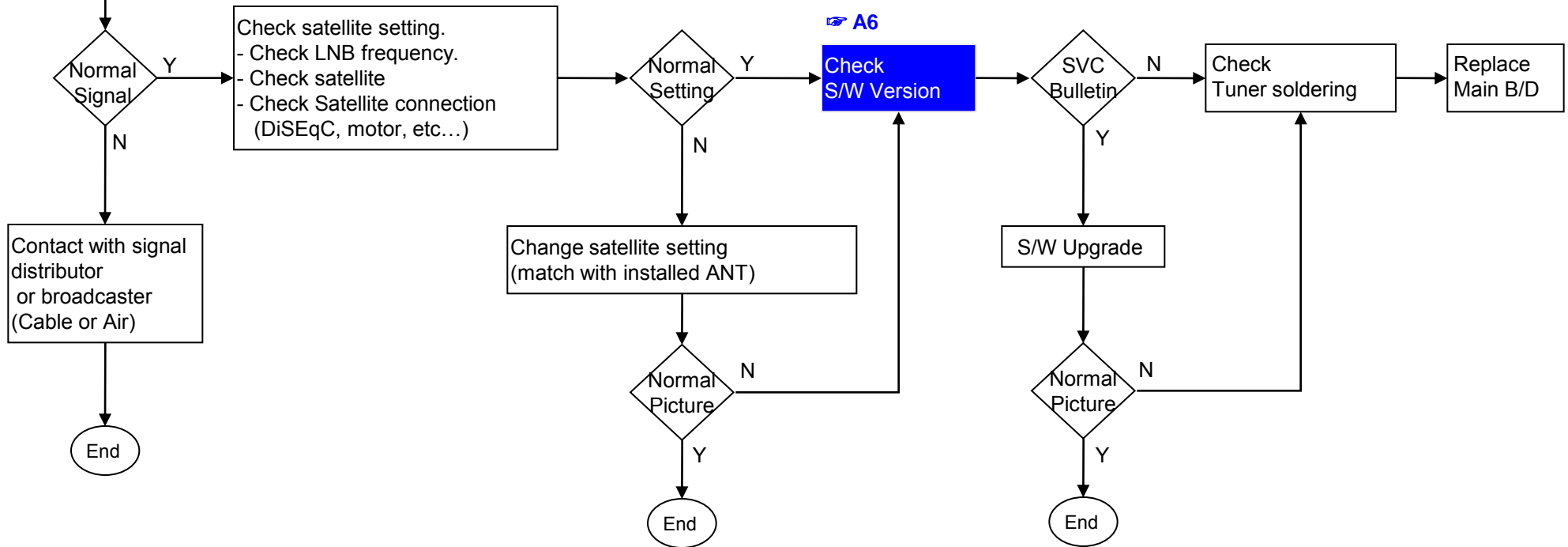

LCD TV	Error symptom	A. Video error	Established date	2012. 01 .14	
		Color error	Revised date		5/14

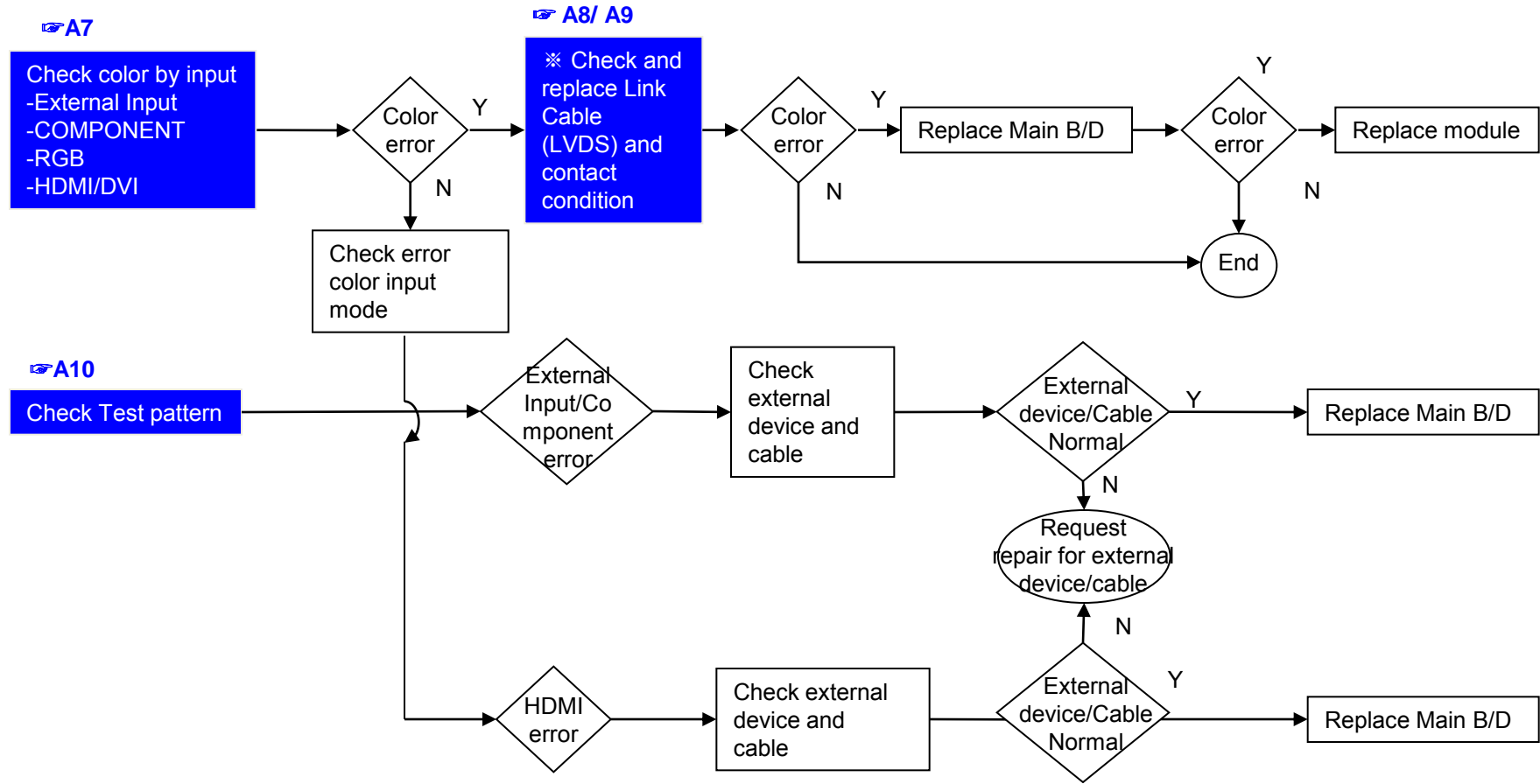

LCD TV	Error symptom	<b>A. Video error</b>	Established date	2012. 01 .14	
		Vertical / Horizontal bar, residual image, light spot, external device color error	Revised date		6/14

### Vertical/Horizontal bar, residual image, light spot

A7

Check color condition by input  
-External Input  
-Component/AV  
-HDMI

A10

Check Test pattern

A8/ A9

Check and replace Link Cable

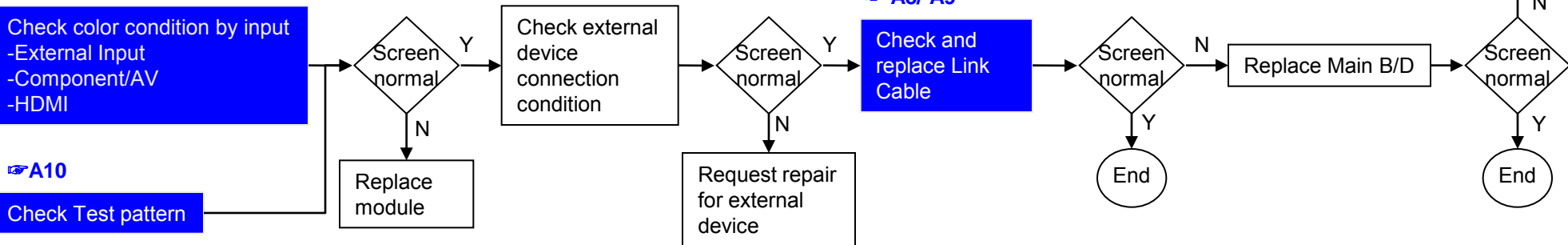

### External device screen error-Color error

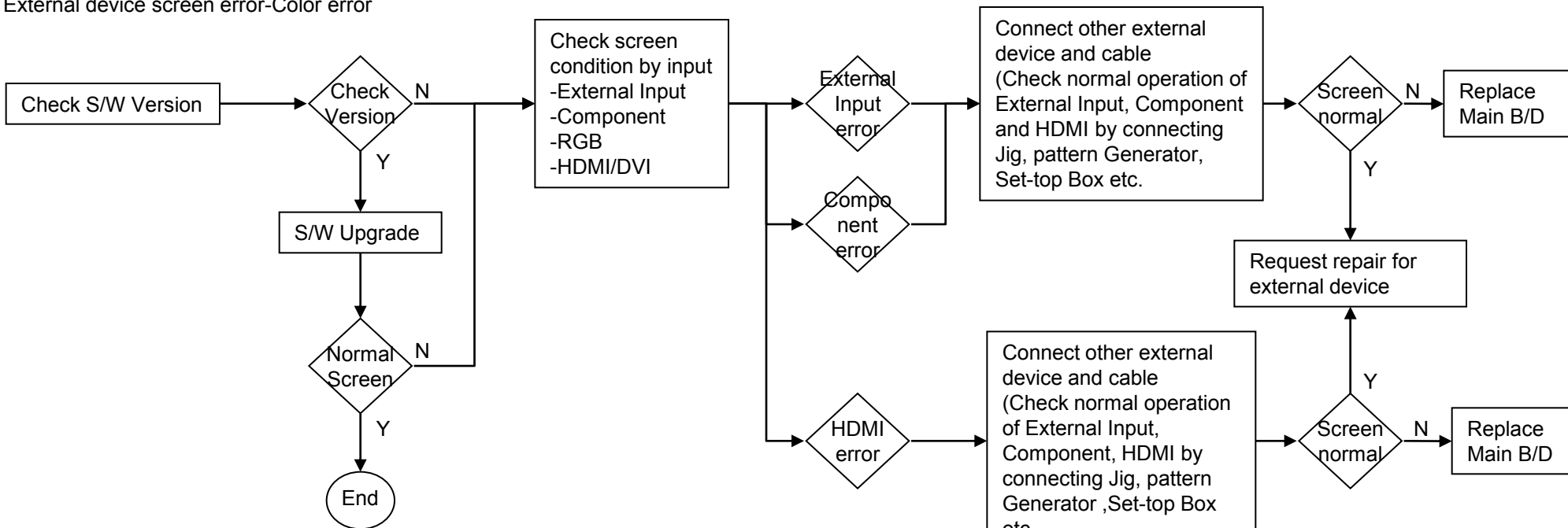

LCD TV	Error symptom	<b>B. Power error</b>	Established date	2012. 01 .14	
		No power	Revised date		7/14

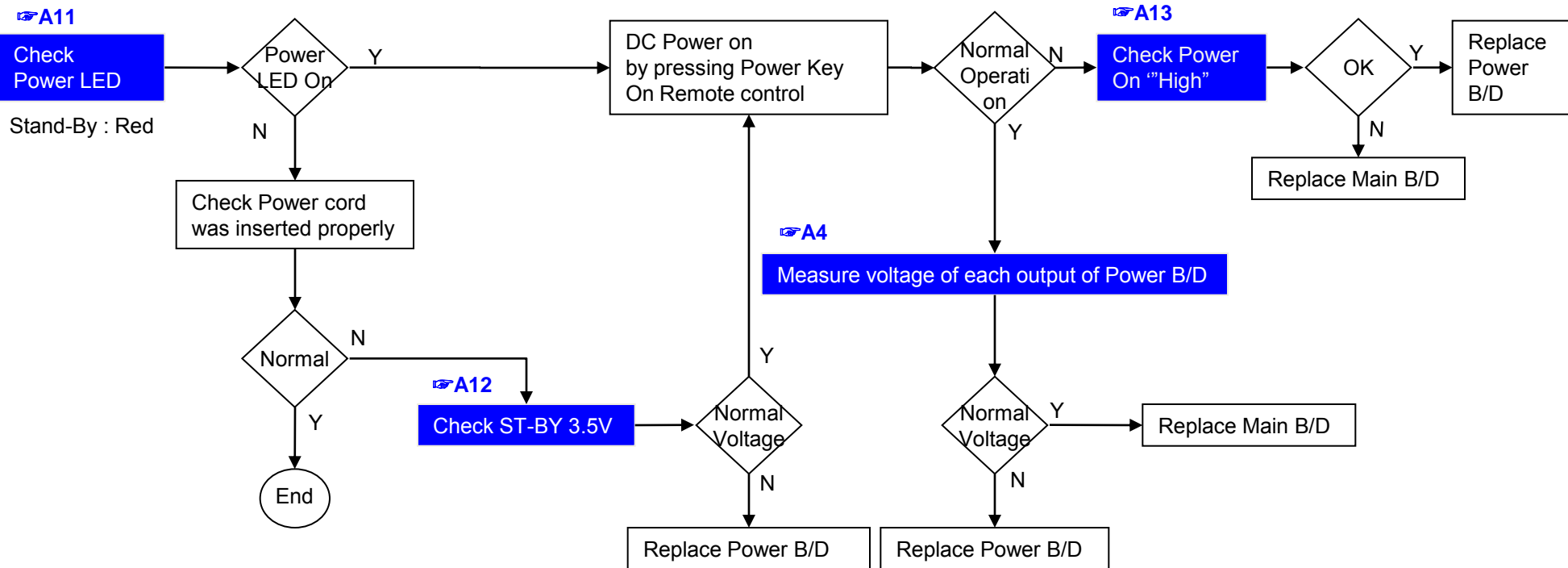

LCD TV	Error symptom	<b>B. Power error</b>	Established date	2012. 01 .14	
		Off when on, off while viewing, power auto on/off	Revised date		8/14

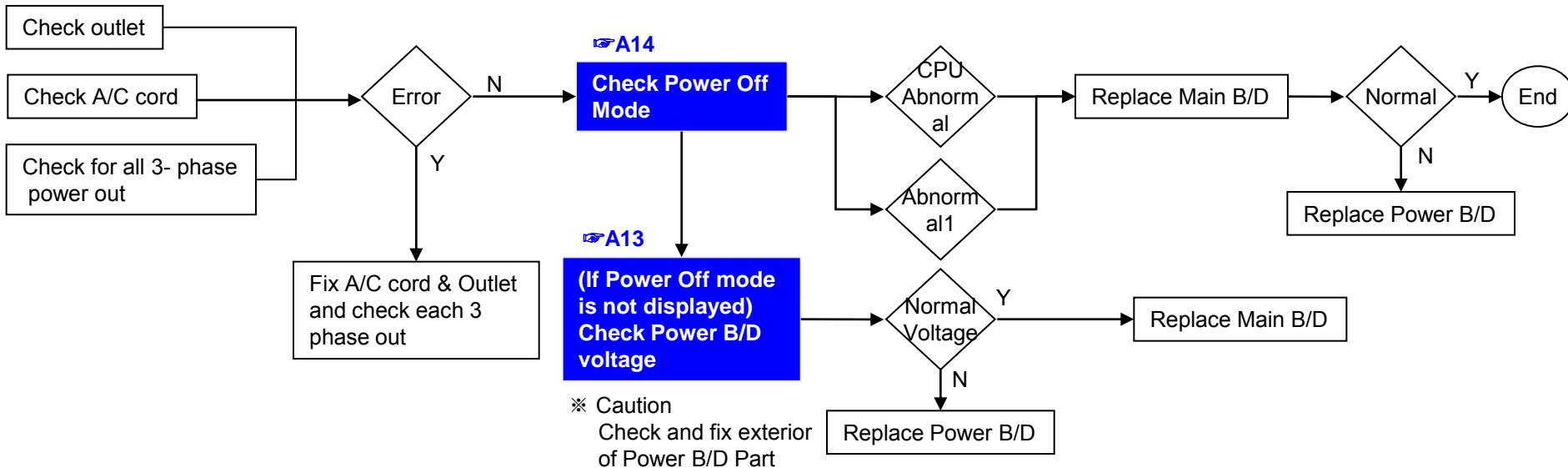

\* Please refer to the all cases which can be displayed on power off mode.

Status	Power off List	Explanation
Normal	"POWEROFF_REMOTEKEY"	Power off by REMOTE CONTROL
	"POWEROFF_OFFTIMER"	Power off by OFF TIMER
	"POWEROFF_SLEEPTIMER"	Power off by SLEEP TIMER
	"POWEROFF_INSTOP"	Power off by INSTOP KEY
	"POWEROFF_AUTOOFF"	Power off by AUTO OFF
	"POWEROFF_ONTIMER"	Power off by ON TIMER
	"POWEROFF_RS232C"	Power off by RS232C
	"POWEROFF_RESREC"	Power off by Reserved Record
	"POWEROFF_RECEND"	Power off by End of Recording
	"POWEROFF_SWDOWN"	Power off by S/W Download
	"POWEROFF_UNKNOWN"	Power off by unknown status except listed case
Abnormal	"POWEROFF_ABNORMAL1"	Power off by abnormal status except CPU trouble
	"POWEROFF_CPUABNORMAL"	Power off by CPU Abnormal

LCD TV	Error symptom	C. Audio error	Established date	2012. 01 .14	
		No audio/ Normal video	Revised date		9/14

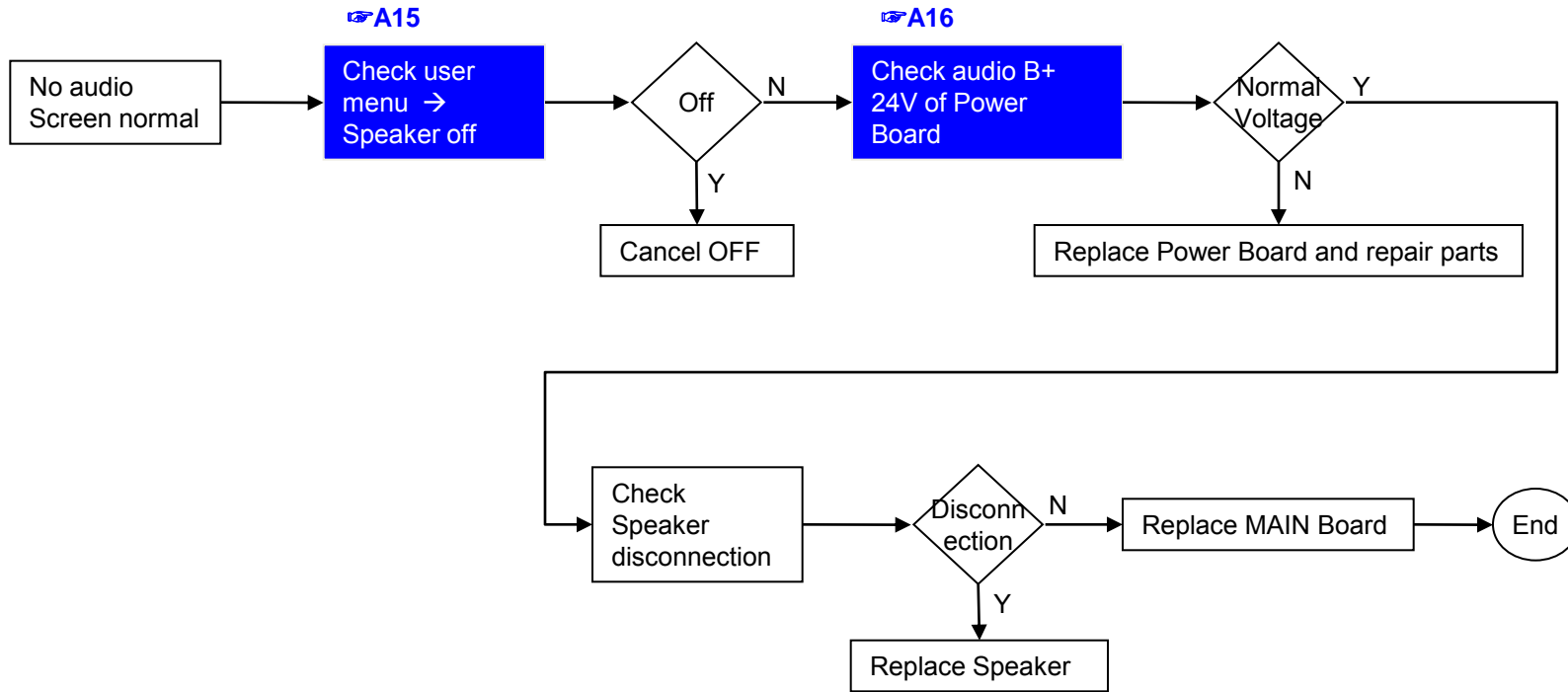



LCD TV	Error symptom	<b>C. Audio error</b>	Established date	2012. 01 .14	
		Wrecked audio/ discontinuation/noise	Revised date		10/14

→ abnormal audio/discontinuation/noise is same after “Check input signal” compared to No audio

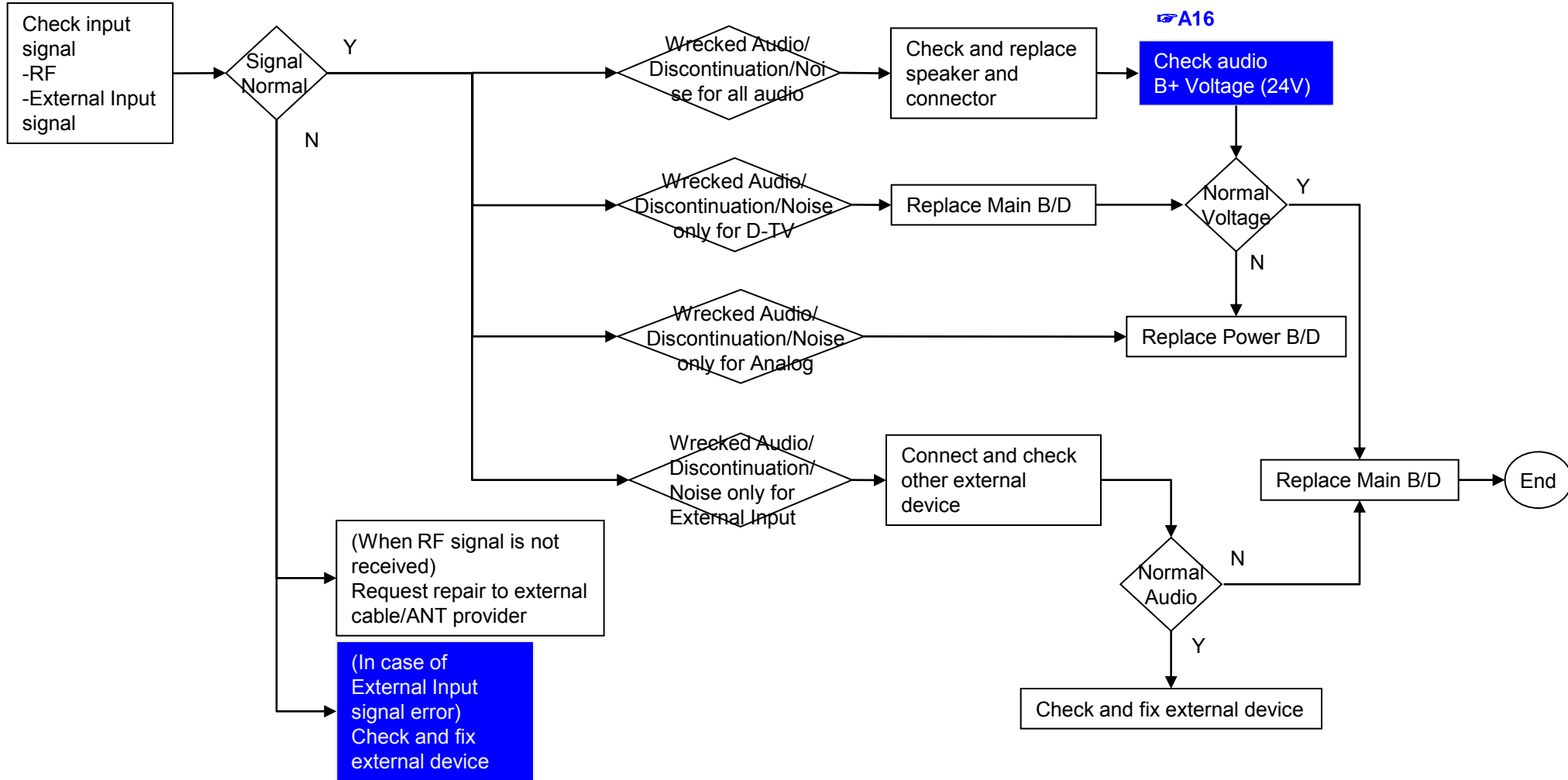

LCD TV	Error symptom	D. Function error	Established date	2012. 01 .14	
		Remote control & Local switch checking	Revised date		11/14

### 1. Remote control(R/C) operating error

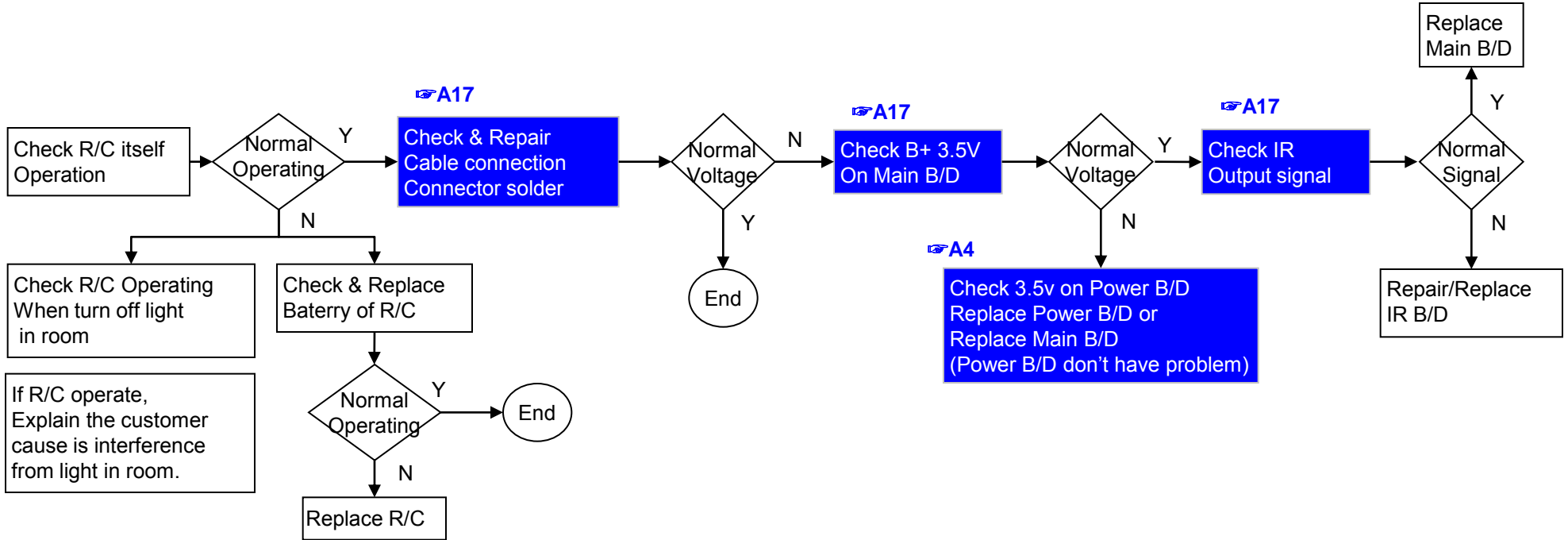

LCD TV	Error symptom	D. Function error	Established date	2012. 01 .14	
		External device recognition error	Revised date		12/14

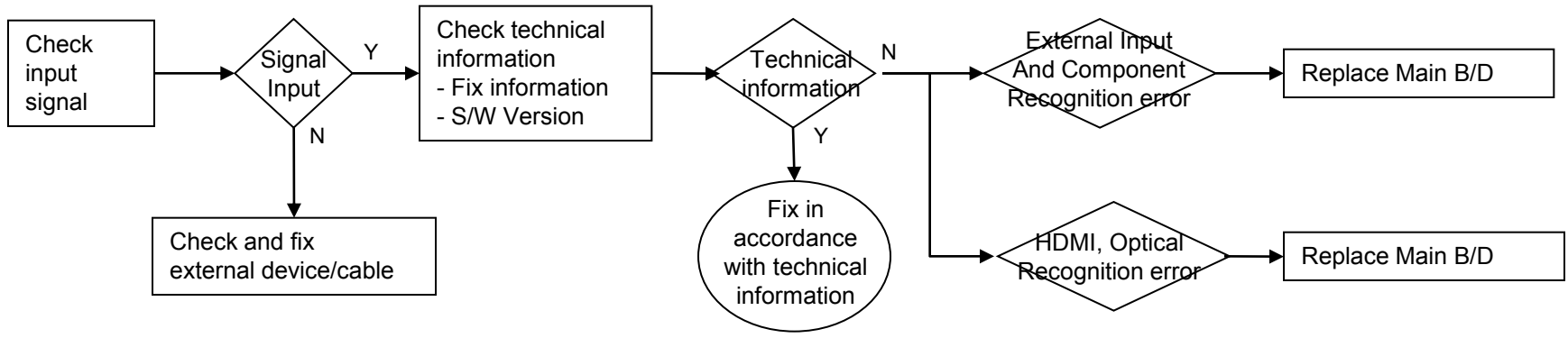

LCD TV	Error symptom	<b>E. Noise</b>	Established date	2012. 01 .14	
		Circuit noise, mechanical noise	Revised date		13/14

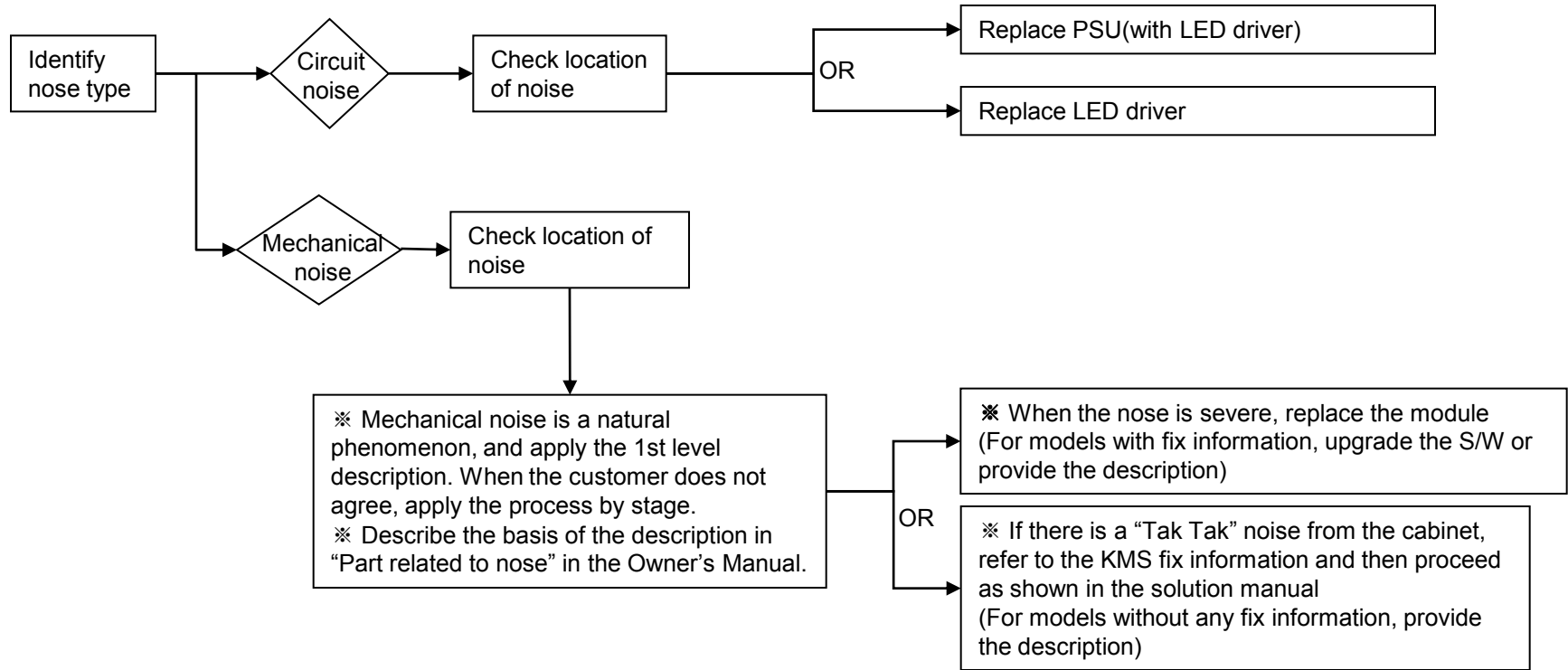

LCD TV	Error symptom	F. Exterior defect	Established date	2012. 01 .14	
		Exterior defect	Revised date		14/14

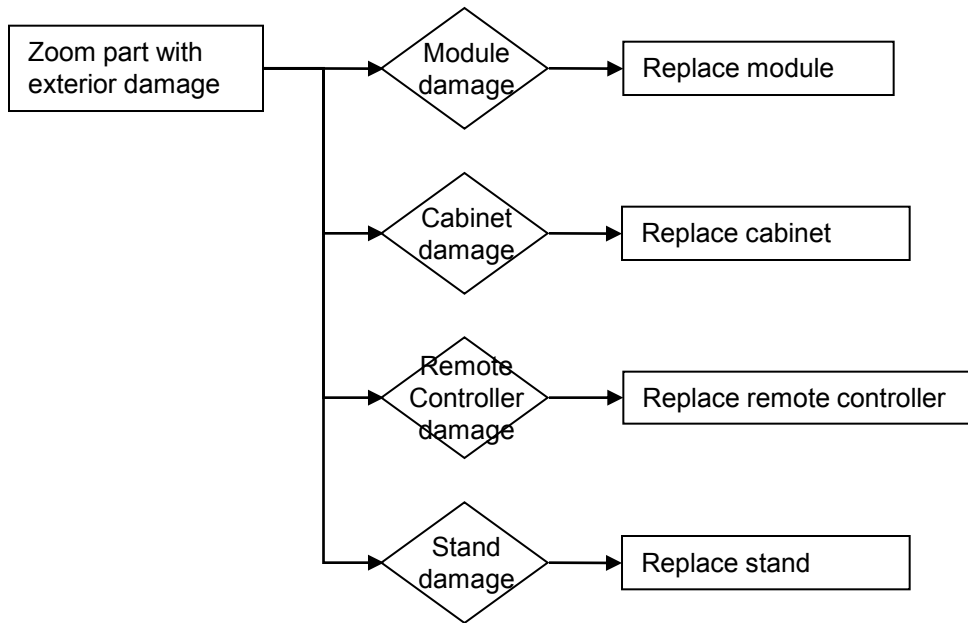

# Contents of LCD TV Standard Repair Process Detail Technical Manual

No.	Error symptom	Content	Page	Remarks
1	A. Video error_ No video/Normal audio	Check LCD back light with naked eye	A1	
2		LED driver B+ 24V measuring method	A2	
3		Check White Balance value	A3	
4		Power Board voltage measuring method	A4	
6	A. Video error_ No video/Video lag/stop	TUNER input signal strength checking method	A5	
7		LCD-TV Version checking method	A6	
9	A. Video error_Color error	LCD TV connection diagram	A7	
10				
11		Check Link Cable (LVDS) reconnection condition	A8 A9	
12		Adjustment Test pattern – ADJ Key	A10	
13	A. Video error_Vertical/Horizontal bar, residual image, light spot	LCD TV connection diagram	A8	
14		Check Link Cable (LVDS) reconnection condition	A8 A9	
15		Adjustment Test pattern – ADJ Key	A10	
16	<b>&lt;Appendix&gt;</b> Defected Type caused by T-Con/ Inverter/ Module	Exchange T-Con Board (1)	A-1/5	
17		Exchange T-Con Board (2)	A-2/5	
18		Exchange LED driver Board (PSU)	A-3/5	55" : driver board Other : PSU
19		Exchange Module itself (1)	A-4/5	
20		Exchange Module itself (2)	A-5/5	

**Continue to the next page**

# Contents of LCD TV Standard Repair Process Detail Technical Manual

Continued from previous page

No.	Error symptom	Content	Page	Remarks
21	B. Power error_No power	Check front display LED	A11	
22		Check power input Voltage & ST-BY 3.5V	A12	
23		Checking method when power is ON	A13	
24		POWER BOARD voltage measuring method	A4	
25				
26	B. Power error_Off when on, off while viewing	POWER OFF MODE checking method	A14	
28	C. Audio error_No audio/Normal video	Checking method in menu when there is no audio	A15	
29		Voltage and speaker checking method when there is no audio	A16	
30	C. Audio error_Wrecked audio/discontinuation	Voltage and speaker checking method in case of audio error	A16	
31	D. Function error_ No response in remote controller, key error	Remote controller operation checking method	A17	

# Standard Repair Process Detail Technical Manual

LCD TV	Error symptom	A. Video error_No video/Normal audio	Established date	2012. 01.14	
	Content	Check Back Light On with naked eye	Revised date		A1

<ALL MODELS>

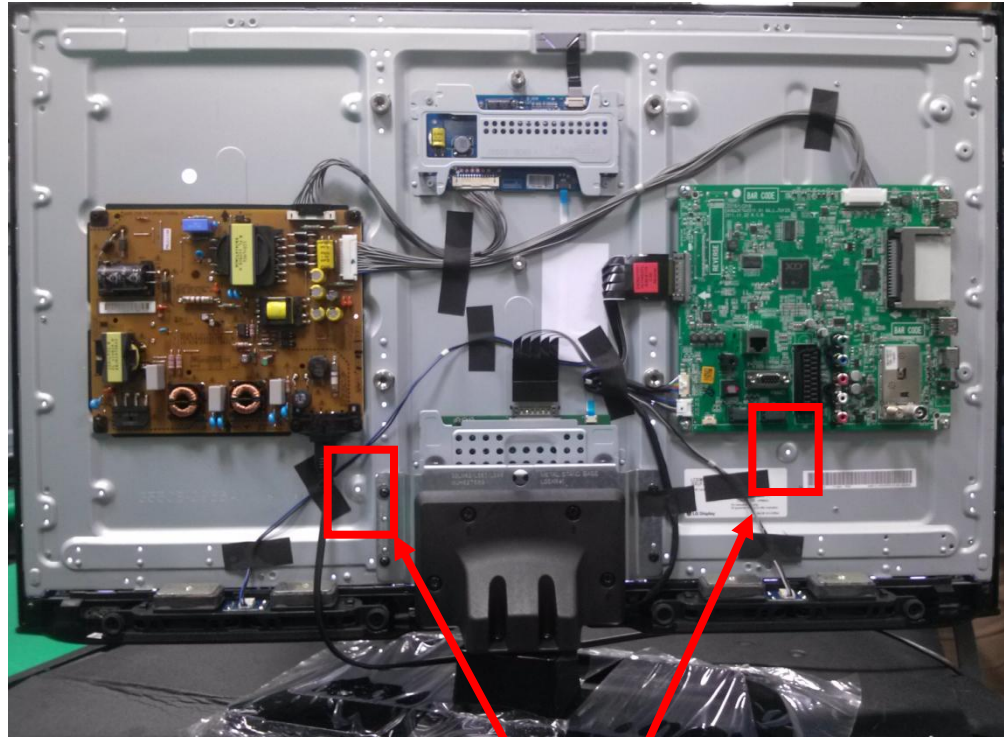

Power On -> disjoint back case -> check lighting at 2 points.



# Standard Repair Process Detail Technical Manual

LCD TV	Error symptom	A. Video error_No video/Normal audio	Established date	2012. 01 .14	
	Content	Inverter B+ 24V measuring method	Revised date		A2



1. Measure DC 24V applying to inverter PCB from Power Board.
2. Output 24V from Power Board -> supply to inverter PCB.  
Check Pin contacting statement and connection statement.

# Standard Repair Process Detail Technical Manual

LCD TV	Error symptom	A. Video error_No video/Normal audio	Established date	2012. 01 .14	
	Content	Check White Balance value	Revised date		A3

<ALL MODELS>

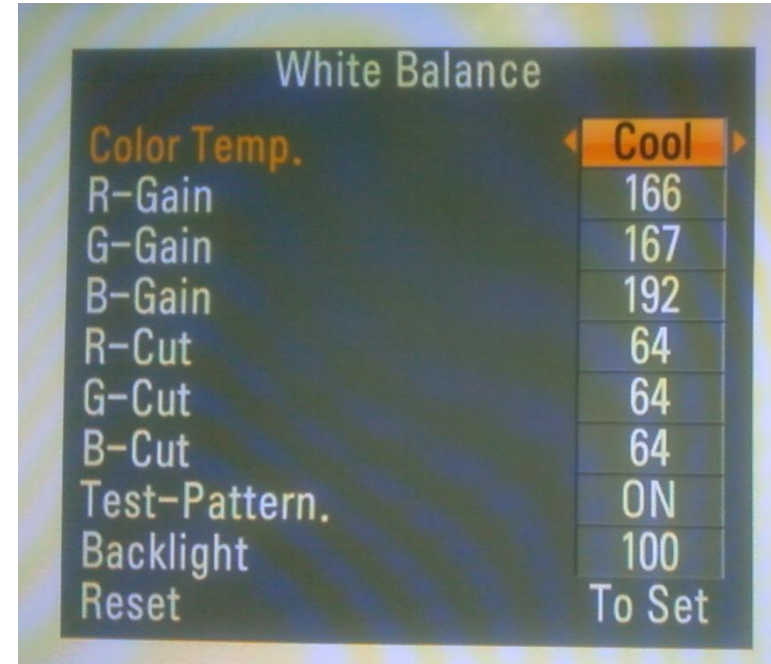
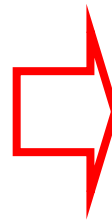
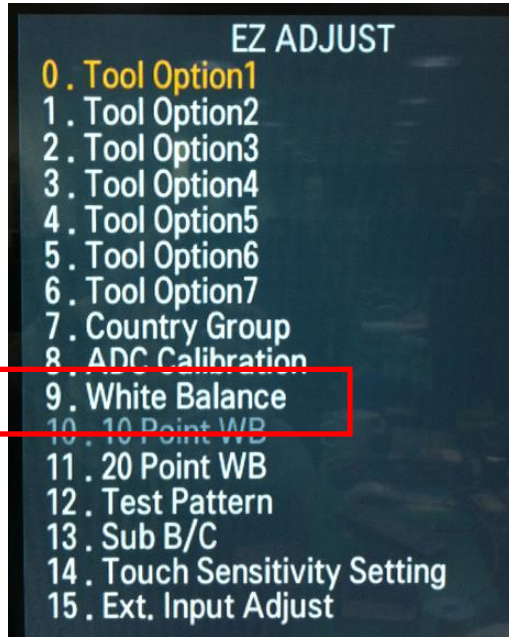

## Entry method

1. Press the ADJ button on the remote controller for adjustment.
2. Enter into White Balance of item 7.
3. After recording the R, G, B (GAIN, Cut) value of Color Temp (Cool/Medium/Warm), re-enter the value after replacing the MAIN BOARD.

# Standard Repair Process Detail Technical Manual

LCD TV	Error symptom	A. Video error_No video/ Audio	Established date	2012. 01 .14	
	Content	Power Board voltage measuring method	Revised date		A4

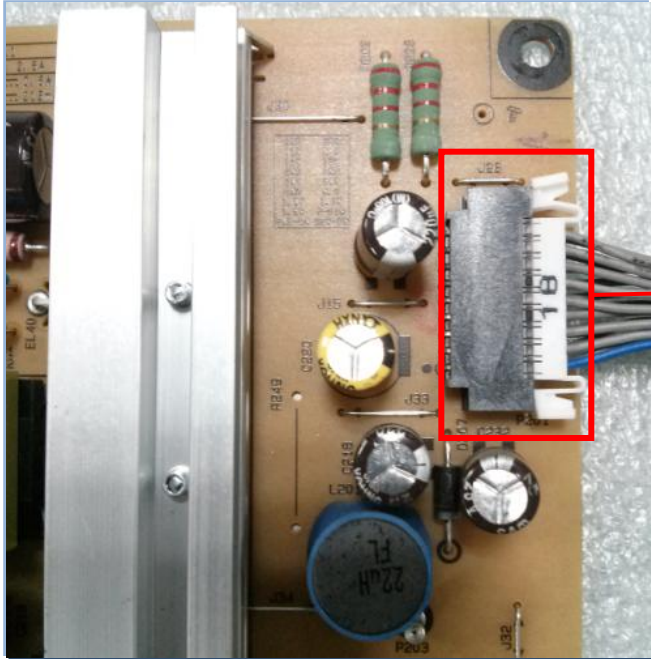

## Check DC 3.5V, 12V, 24V

18 Pin (Power Board ↔ Main Board)			
SMAW200-H18S5			
1	Power on	2	DRV ON
3	3.5V	4	PDIM#1
5	3.5V	6	3.5V
7	GND	8	PDIM#2
9	24V	10	24V
11	GND	12	GND
13	12V	14	12V
15	12V	16	NC
17	GND	18	GND

# Standard Repair Process Detail Technical Manual

LCD TV	Error symptom	A. Video error_Video error, video lag/stop	Established date	2012. 01 .14	
	Content	TUNER input signal strength checking method	Revised date		A5



MENU => Press red key Remote controller=>signal test  
=> Select channel



When the signal is strong, use the attenuator (-10dB, -15dB, -20dB etc.)

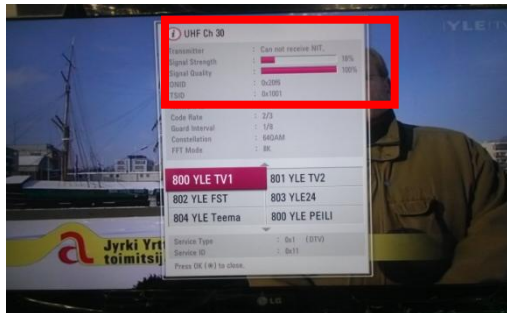

# Standard Repair Process Detail Technical Manual

LCD TV	Error symptom	A. Video error_Video error, video lag/stop	Established date	2012. 01 .14	
	Content	LCD-TV Version checking method	Revised date		A6

## 1. Checking method for remote controller for adjustment

Version

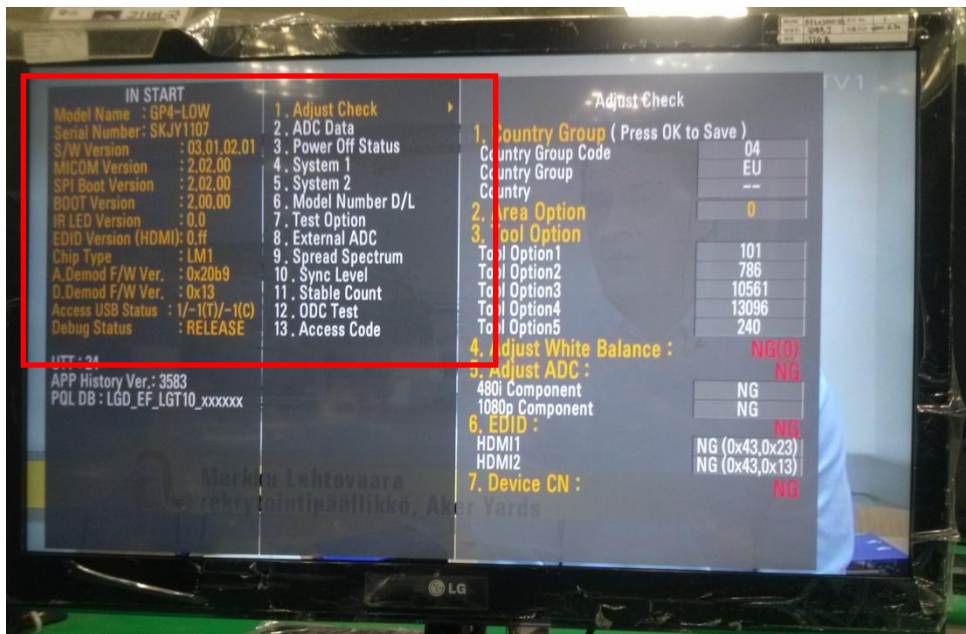

Press the IN-START with the remote controller for adjustment

# Standard Repair Process Detail Technical Manual

LCD TV	Error symptom	A. Video error _Vertical/Horizontal bar, residual image, light spot	Established date	2012. 01 .14	
	Content	LCD TV connection diagram (1)	Revised date		A7

<ALL MODELS>

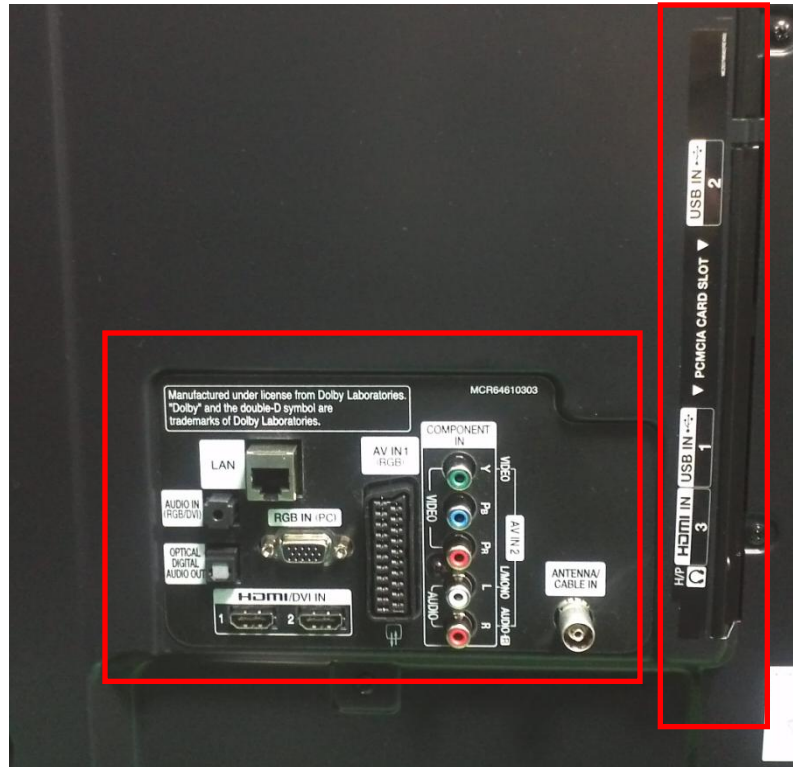

**As the part connecting to the external input, check the screen condition by signal**

# Standard Repair Process Detail Technical Manual

LCD TV	Error symptom	A. Video error_Color error	Established date	2012. 01 .14	
	Content	Check and replace Link Cable(LVDS) and contact condition	Revised date		A8/A9

<ALL MODELS>

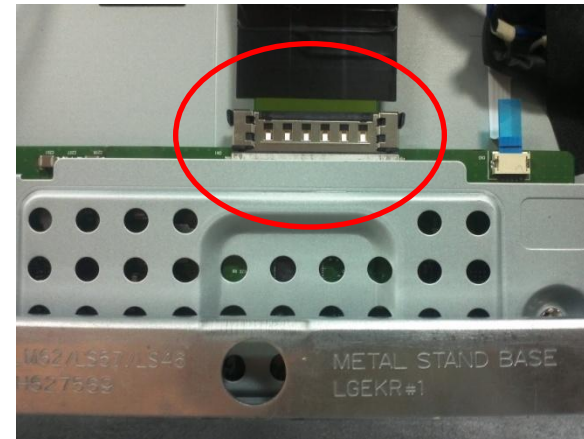
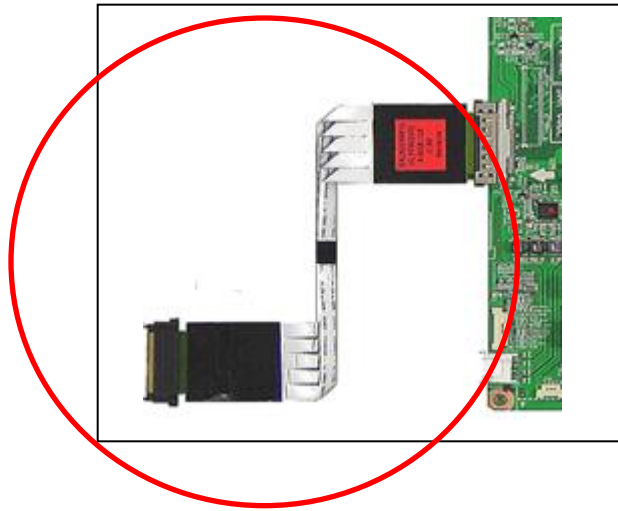

1. Check and replace LVDS Cable
2. Check LVDS connection condition

# Standard Repair Process Detail Technical Manual

LCD TV	Error symptom	A. Video error_Color error	Established date	2012. 01 .14	
	Content	Adjustment Test pattern - ADJ Key	Revised date		A10

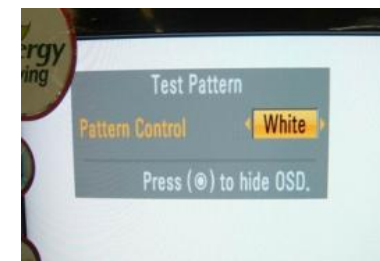
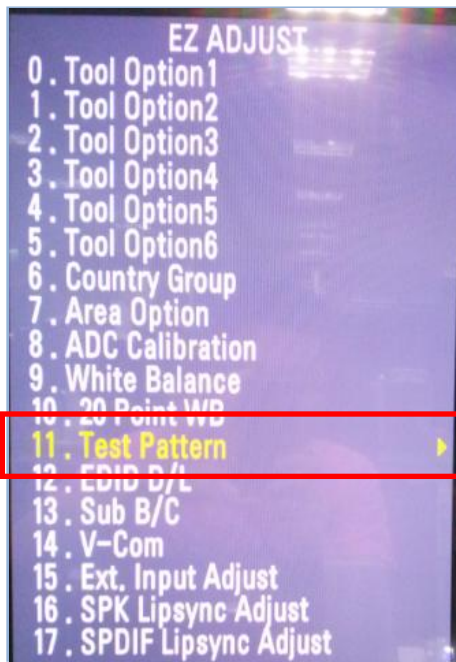

You can view 6 types of patterns using the ADJ Key

Checking item : 1. Defective pixel 2. Residual image 3. MODULE error (ADD-BAR,SCAN BAR..)  
4.Video error (Classification of MODULE or Main-B/D!)



# Appendix : Exchange T-Con Board (1)



Solder defect, CNT Broken



Solder defect, CNT Broken

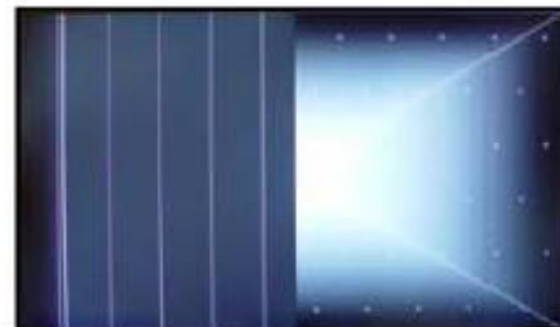

Solder defect, CNT Broken



Solder defect, CNT Broken

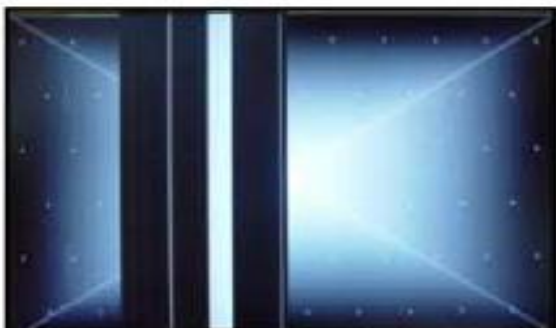

Solder defect, CNT Broken



Abnormal Power Section

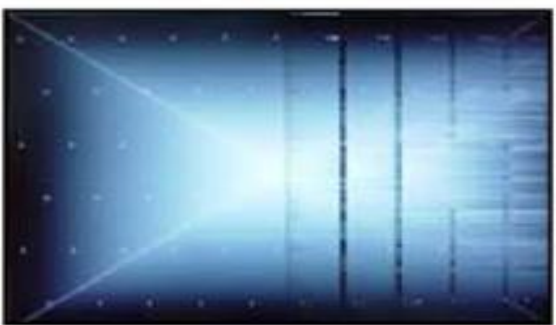

Solder defect, Short/Crack



Abnormal Power Section



Solder defect, Short/Crack

# Appendix : Exchange T-Con Board (2)

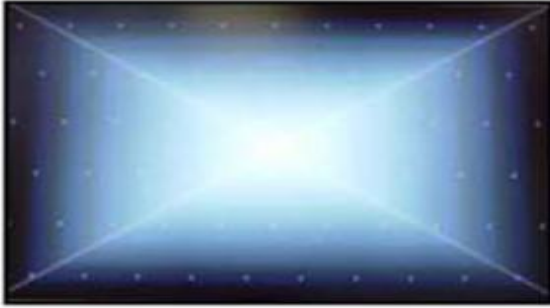

Abnormal Power Section



Abnormal Power Section



Solder defect, Short/Crack



Solder defect, Short/Crack



Fuse Open, Abnormal power section



Abnormal Display

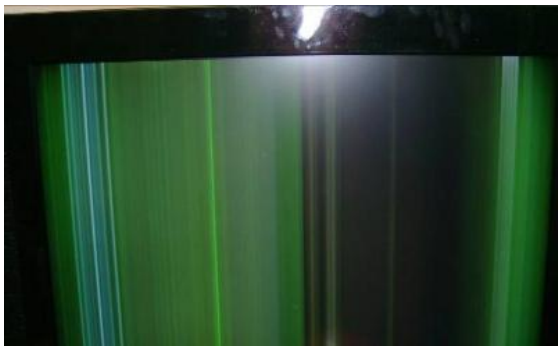

GRADATION



Noise



GRADATION

# Appendix : Exchange PSU(LED driver)



No Light



Dim Light



Dim Light

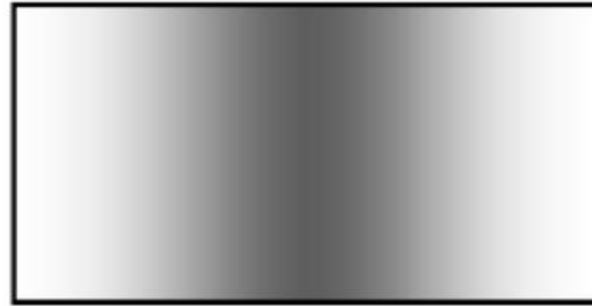

Dim Light



No picture/Sound Ok

# Appendix : Exchange the Module (1)



Panel Mura, Light leakage



Panel Mura, Light leakage



Press damage

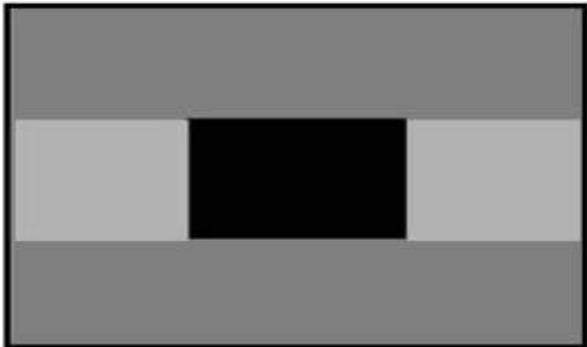

Crosstalk



Press damage



Crosstalk



Press damage

## Un-repairable Cases

In this case please exchange the module.

## Appendix : Exchange the Module (2)

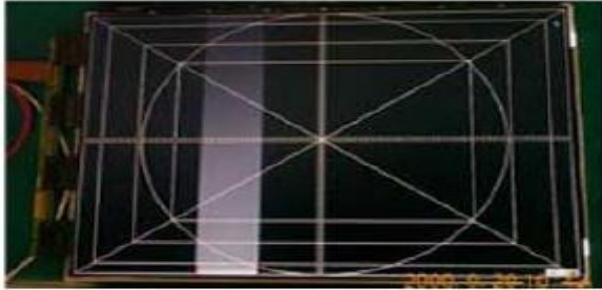

Vertical Block  
Source TAB IC Defect



Vertical Line  
Source TAB IC Defect



Vertical Block  
Source TAB IC Defect



Horizontal Block  
Gate TAB IC Defect

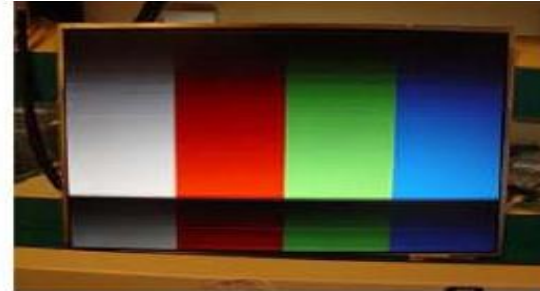

Horizontal Block  
Gate TAB IC Defect

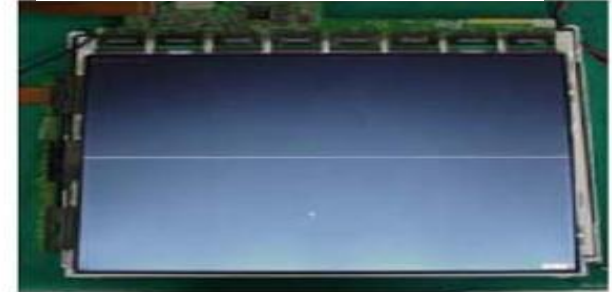

Horizontal line  
Gate TAB IC Defect

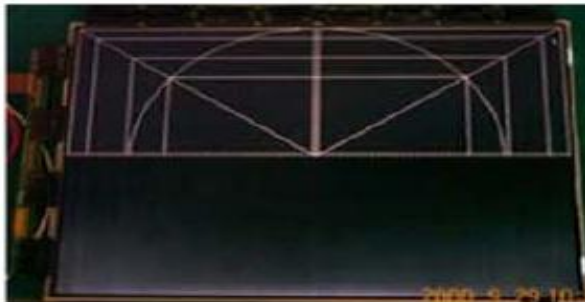

Horizontal Block  
Gate TAB IC Defect

### Un-repairable Cases

In this case please exchange the module.

# Standard Repair Process Detail Technical Manual

LCD TV	Error symptom	B. Power error _No power	Established date	2012. 01 .14	
	Content	Check front display LED	Revised date		A11

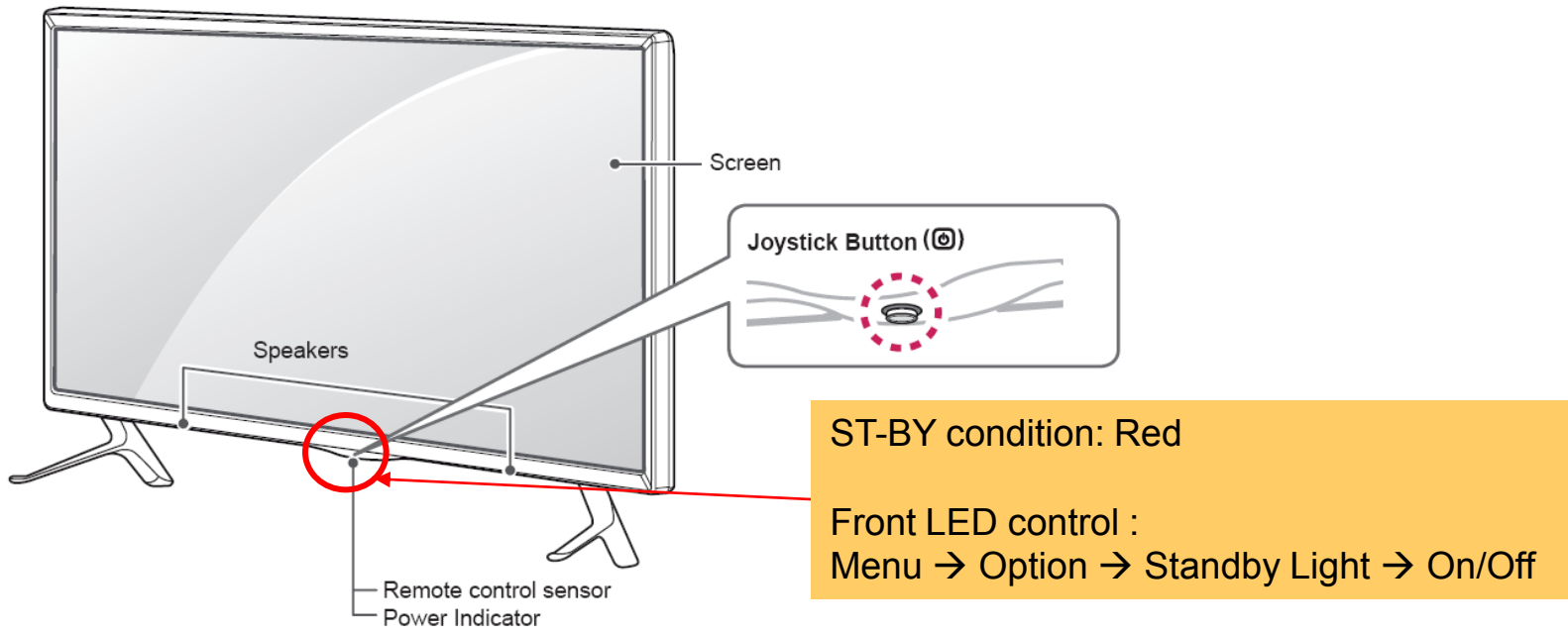

# Standard Repair Process Detail Technical Manual

LCD TV	Error symptom	B. Power error _No power	Established date	2012. 01 .14	
	Content	Check power input voltage and ST-BY 5V	Revised date		A12

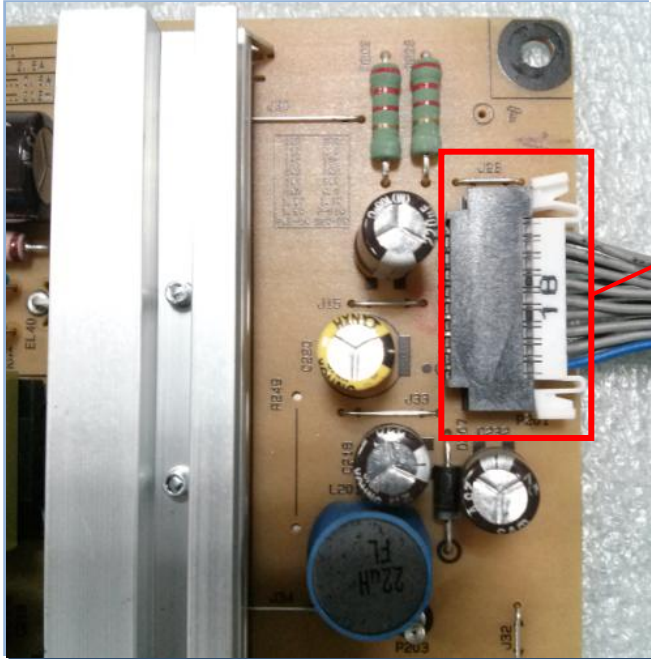

## Check DC 3.5V, 12V, 24V

18 Pin (Power Board ↔ Main Board)			
SMAW200-H18S5			
1	Power on	2	DRV ON
3	3.5V	4	PDIM#1
5	3.5V	6	3.5V
7	GND	8	PDIM#2
9	24V	10	24V
11	GND	12	GND
13	12V	14	12V
15	12V	16	NC
17	GND	18	GND

# Standard Repair Process Detail Technical Manual

LCD TV	Error symptom	B. Power error _No power	Established date	2012. 01 .14	
	Content	Checking method when power is ON	Revised date		A13

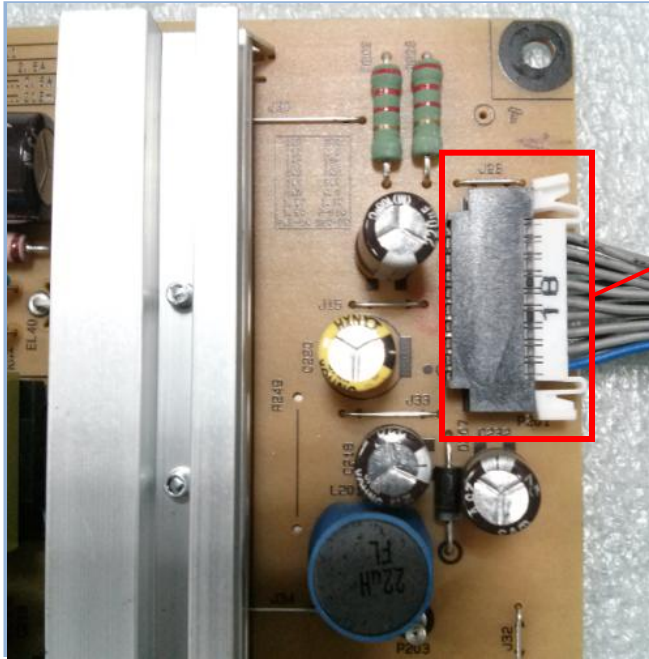

Check "power on(Pin 1)" pin is high(about 3.3V)

18 Pin (Power Board ↔ Main Board)			
SMAW200-H18S5			
1	Power on	2	DRV ON
3	3.5V	4	PDIM#1
5	3.5V	6	3.5V
7	GND	8	PDIM#2
9	24V	10	24V
11	GND	12	GND
13	12V	14	12V
15	12V	16	NC
17	GND	18	GND



# Standard Repair Process Detail Technical Manual

LCD TV	Error symptom	B. Power error _Off when on, off whiling viewing	Established date	2012. 01 .14	
	Content	POWER OFF MODE checking method	Revised date		A14

<ALL MODELS>

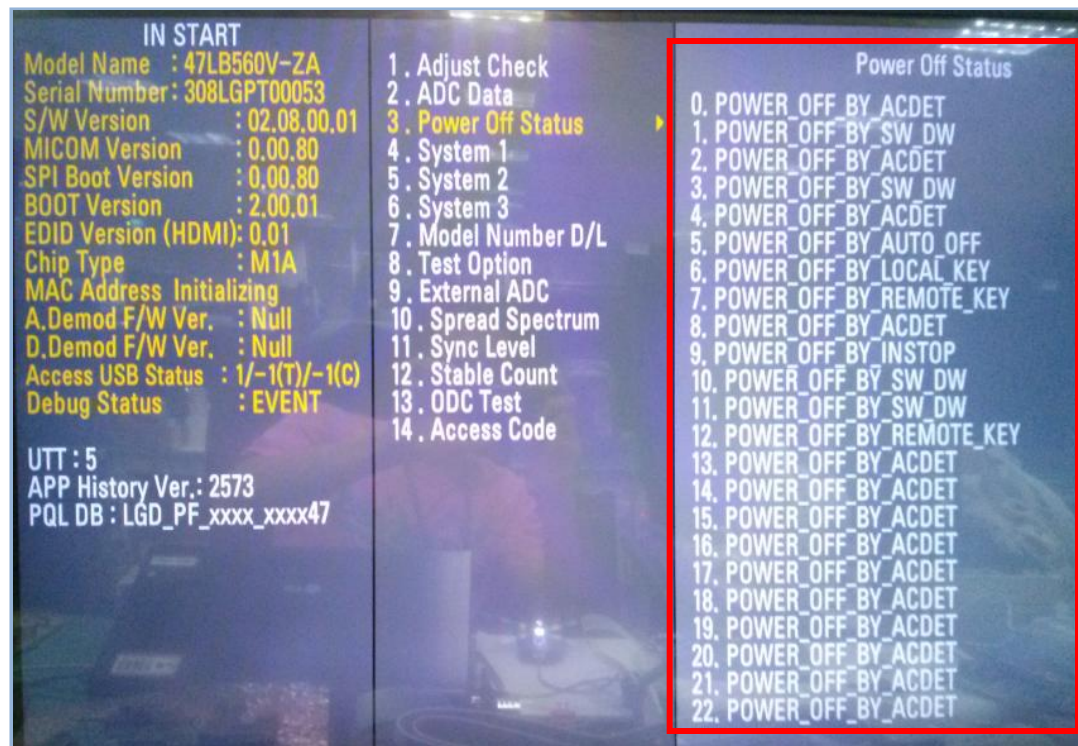

## Checking order

1. Press the IN-START button of the remote controller for adjustment
2. Check the entry into adjustment item 3.

# Standard Repair Process Detail Technical Manual

LCD TV	Error symptom	C. Audio error_No audio/Normal video	Established date	2012. 01 .14	
	Content	Checking method in menu when there is no audio	Revised date		A15

<ALL MODELS>

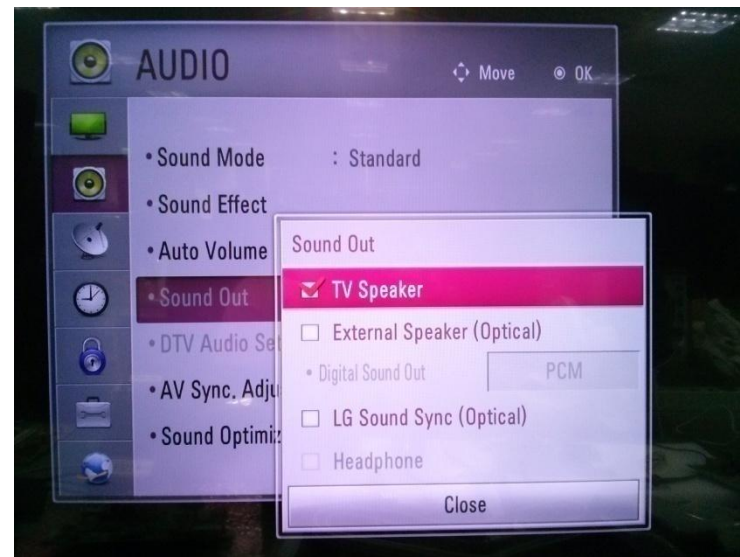
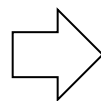
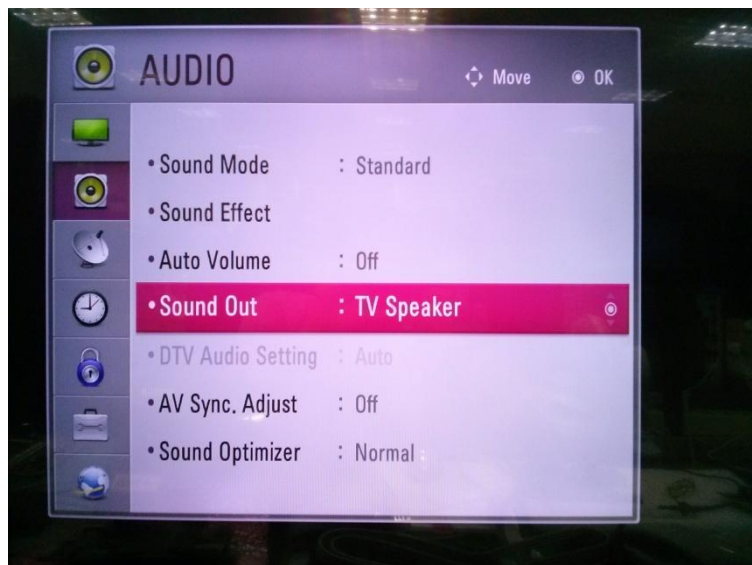

## Checking order

1. Press the MENU button on the remote controller
2. Select the AUDIO function of the Menu
3. Select TV Speaker Check

# Standard Repair Process Detail Technical Manual

LCD TV	Error symptom	C. Audio error_No audio/Normal video	Established date	2012. 01 .14	
	Content	Voltage and speaker checking method when there is no audio	Revised date		A16

<ALL MODELS>

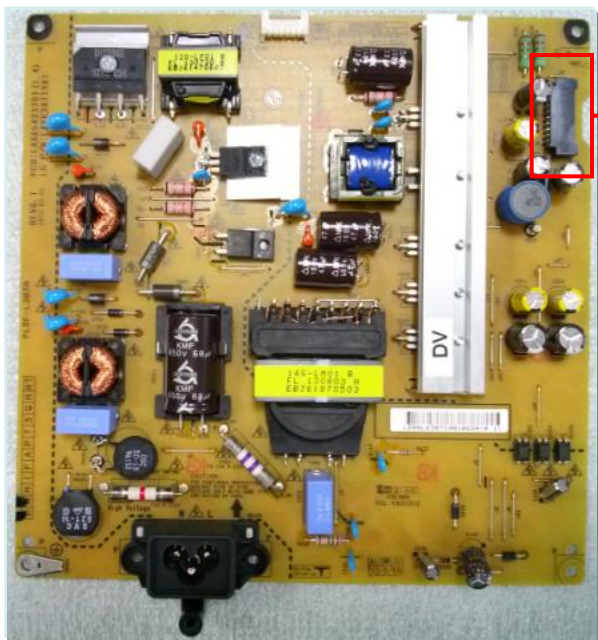

18 Pin (Power Board ↔ Main Board)			
SMAW200-H18S5			
1	Power on	2	DRV ON
3	3.5V	4	PDIM#1
5	3.5V	6	3.5V
7	GND	8	PDIM#2
9	24V	10	24V
11	GND	12	GND
13	12V	14	12V
15	12V	16	NC
17	GND	18	GND

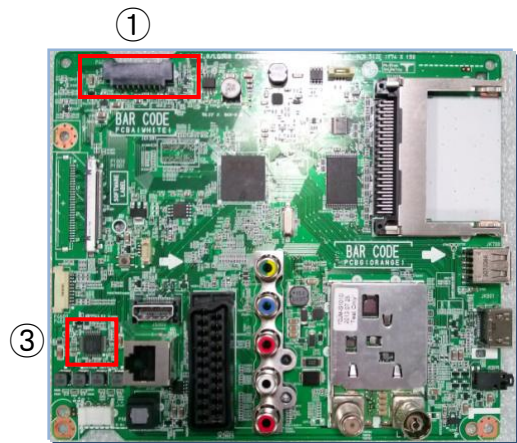

< Main Ass'y >

## Checking order

1. Check the contact condition of or 24V connector of Main Board
2. Measure the 24V input voltage supplied from Power Board  
(If there is no input voltage, remove and check the connector)
3. Connect the tester RX1 to the speaker terminal and if you hear the Chik Chik sound when you touch the GND and output terminal, the speaker is normal.

# Standard Repair Process Detail Technical Manual

LCD TV	Error symptom	D. Function error_ No response in remote controller, key error	Established date	2012. 01 .14	
	Content	Remote controller operation checking method	Revised date		A17

<ALL MODELS>

P4600

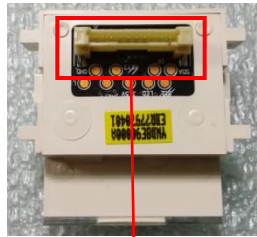

① < Sub Ass'y>

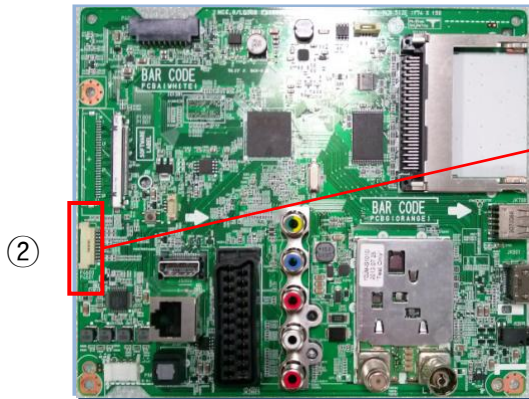

< Main Ass'y>

1	GND
2	KEY1
3	KEY2
4	3.5V_ST
5	GND
6	LED R
7	IR
8	GND
9	SCL
10	SDA

## Checking order

- 1, 2. Check IR cable condition between IR & Main board.
3. Check the st-by 3.3V on the terminal 4.
4. When checking the Pre-Amp when the power is in ON condition, it is normal when the Analog Tester needle moves slowly, and defective when it does not move at all.