



Service Manual

Microwave oven

JT 359/BL

Model Version		Page
	JT 359/BL	
	8587 359 99491	
	Introduction safety	2
	Technical data	3
	Spare part list	4
	Exploded view	5
	Wiring diagram	6

Introduction safety

INTRODUCTION

Before leaving the factory each oven is carefully checked.
It must, however, be installed and used correctly.

Despite all the steps taken to make the oven safe, the safety is dependent on the correct installation and the fact the user understands how to use and maintain the oven.

The information in this section should be used as a reminder that the oven is safe and that anyone who uses it must first read the instructions for use in order to be able to use the oven correctly and obtain best results.

SAFETY

To avoid injury to yourself and damage to the appliance always work to the following rules when servicing an oven.

Always disconnect the plug from the mains before starting work.

If there is no plug switch off the electric supply at the control box.

When you have finished servicing an oven before you reconnect it to the mains, make sure that:

- all the internal connections are correct
- the wires are insulated and not touching the door or the cabinet or anything sharp
- all the earth connections are electrically and mechanically sound
- do not modify or anyway interfere with the safety devices built-in to the oven

- make sure that each replacement part you use conforms to the manufacturer's specifications

Do not start a repair if you have any doubt as to your ability to complete it.

CAUTION - MICROWAVE RADIATION

PERSONNEL SHOULD NOT BE EXPOSED TO THE MICROWAVE ENERGY WHICH MAY RADIATE FROM THE MAGNETRON, WAVEGUIDE OR ANTENNA IF THEY ARE IMPROPERLY USED OR CONNECTED. ALL INPUT AND OUTPUT MICROWAVE CONNECTIONS, WAVEGUIDES, FLANGES AND GASKETS MUST BE SECURE. NEVER OPERATE THE DEVICE WITHOUT A MICROWAVE ENERGY ABSORBING LOAD ATTACHED. NEVER LOOK INTO AN OPEN WAVEGUIDE OR ANTENNA WHILE THE DEVICE IS ENERGIZED. NEVER OPERATE AN OVEN WITH CABINET OFF WITHOUT MEASURING THE MICROWAVE LEAKAGE AROUND MAGNETRON AND VISIBLE MICROWAVE CONNECTIONS (WELDING JOINTS).

Do not operate the oven if the following conditions exist:

- the door does not close firmly against the door support because of the door being warped or the hinges damaged.
- The door trims or seals are damaged.
- If there is any visible damage to the oven.
- if the door does not close properly.

Avoid operating the oven if known components in the interlock system, oven door or microwave generating assembly are known defective. They must be replaced.

WARNING - HIGH VOLTAGE

IT IS POSSIBLE TO COME IN CONTACT WITH LETHAL HIGH VOLTAGE WHEN WORKING WITH HV TRANSFORMER, HV CAPACITOR AND MAGNETRON. THEREFORE NEVER TRY TO MEASURE THE HIGH VOLTAGE. ALWAYS TAKE UTMOST CARE WHEN PERFORMING ELECTRIC MEASUREMENTS INSIDE THE OVEN.

Technical data

Product dimensions

Height	377	mm
Width	493	mm
Depth	487	mm

Cavity dimensions

Height	210	mm
Width	395	mm
Depth	370	mm
Cavity volume	31	l
Turntable diameter	360	mm

Weight

Net	31.4	kg
-----	------	----

Electrical

Voltage	230 - 240	V
Frequency	50	Hz

Power

Output power MW	1000	W
Grill	1200	W
Forced air	1500	W
Microwave frequency 5 power levels	2450	MHz

Error codes

Certain fault conditions are indicated by an error code.
The following codes are implemented:

Error code	Description
ERR 1	MW Relay error
ERR 2	Keyboard error
ERR 3	Cavity temperature sensor error
ERR 4	Ambient temperature sensor error Magnetron temperature sensor error
ERR 5	Switched mode power supply (SMPS) error
ERR 7	Humidity sensor error
ERR 8	EEPROM error

Spare part list

Model JT 359/BL
Service No. 858735999491
Version 858735999491

Pos. No.	12NC Code	Description
001 0	4812 440 11244	Cabinet BL
011 0	4812 462 79908	Foot left
011 1	4812 462 79909	Foot right
041 2	4812 417 78144	Pin hinge
041 3	4812 401 18672	Ring fixation
044 0	4812 417 78145	Hinge door spring
050 0	4812 462 38234	Cover
110 0	4812 498 78644	Door handle BL
117 0	4812 498 78626	Handle for crisp plate
120 0	4812 464 48186	Door, inner
121 0	4812 464 48185	Door frame inner
130 0	4812 270 18041	Holder SWITCH
130 2	4812 404 78463	Cam plate
130 4	4819 902 00756	Spring
130 6	4812 491 48032	Hook door
143 0	4812 459 38072	Door frame outer BL
244 1	4812 466 88777	Cover for food
245 0	4812 458 19293	Grill grid (H)
245 1	4812 466 78434	Grill grid (L)
246 0	4812 466 78428	Crisp plate
247 0	4812 466 48103	Baking tray
255 0	4819 466 78348	Turntable glass
264 0	4812 535 78087	Turntable ring
264 1	4812 462 38233	Turntable driver
264 2	4812 535 78086	Wheel tt
301 0	4812 453 50126	Panel ring
305 0	4812 404 68054	Support PCB
321 0	4812 130 38757	Lens inlay
331 2	4812 411 29027	Button manual
331 3	4812 411 29031	Button 6th
333 0	4812 411 29028	Button start
333 1	4812 411 29025	Button stop
334 7	4812 411 29024	Button plus
334 8	4812 411 29026	Button minus
404 0	4812 131 58808	Magnetron
406 0	4812 361 58156	Motor Turntable
412 0	4812 145 38045	Transformer HT
420 0	4812 121 58151	Capacitor HT
421 0	4819 902 00535	Filter, mains
426 0	4812 218 38225	Diode HT
440 0	4819 361 18439	Motor
440 3	4812 522 38003	Belt FC
440 4	4812 404 78719	Bearing FC ball assy
441 0	4812 361 78029	Motor, fan
443 0	4812 515 28106	Fan wheel
443 1	4812 445 28042	Housing
443 2	4812 530 58162	Spring lock
443 5	4819 358 18151	Belt pulley FC-Wheel
443 8	4812 530 58178	Pin FC
443 9	4812 462 79915	Rail FC
451 0	4812 134 58014	Heating element FC
451 2	4812 530 58161	Washer
452 0	4812 134 58013	Heating element
485 2	4812 321 18251	Cable communication
490 0	4812 321 18252	Cable, mains

Pos. No.	12NC Code	Description
500 0	4812 209 88054	Control board
561 0	4812 282 08652	Thermostat
562 0	4819 902 00761	Thermostat
566 0	4812 282 48288	Thermostat
571 0	4819 360 58589	Valve flap
571 1	4812 462 79914	Valve driver
633 0	4812 271 38395	Switch, door
651 0	4812 134 88071	Lamp
656 0	4812 462 58088	Reflector
656 1	4812 462 58089	Glass lamp
691 0	4812 210 78018	Sensor temperature
691 1	4812 210 78033	Sensor humidity
774 0	4812 462 28699	Cover mica plate
901 1	4812 214 79403	Clamp cable
971 0	4819 252 28125	Fuse T10A
971 1	4819 256 38016	Bracket for fuse
972 0	4819 253 38011	Fuse T250mA special
993 5	4812 310 88418	Accessory STEAMER

Exploded view

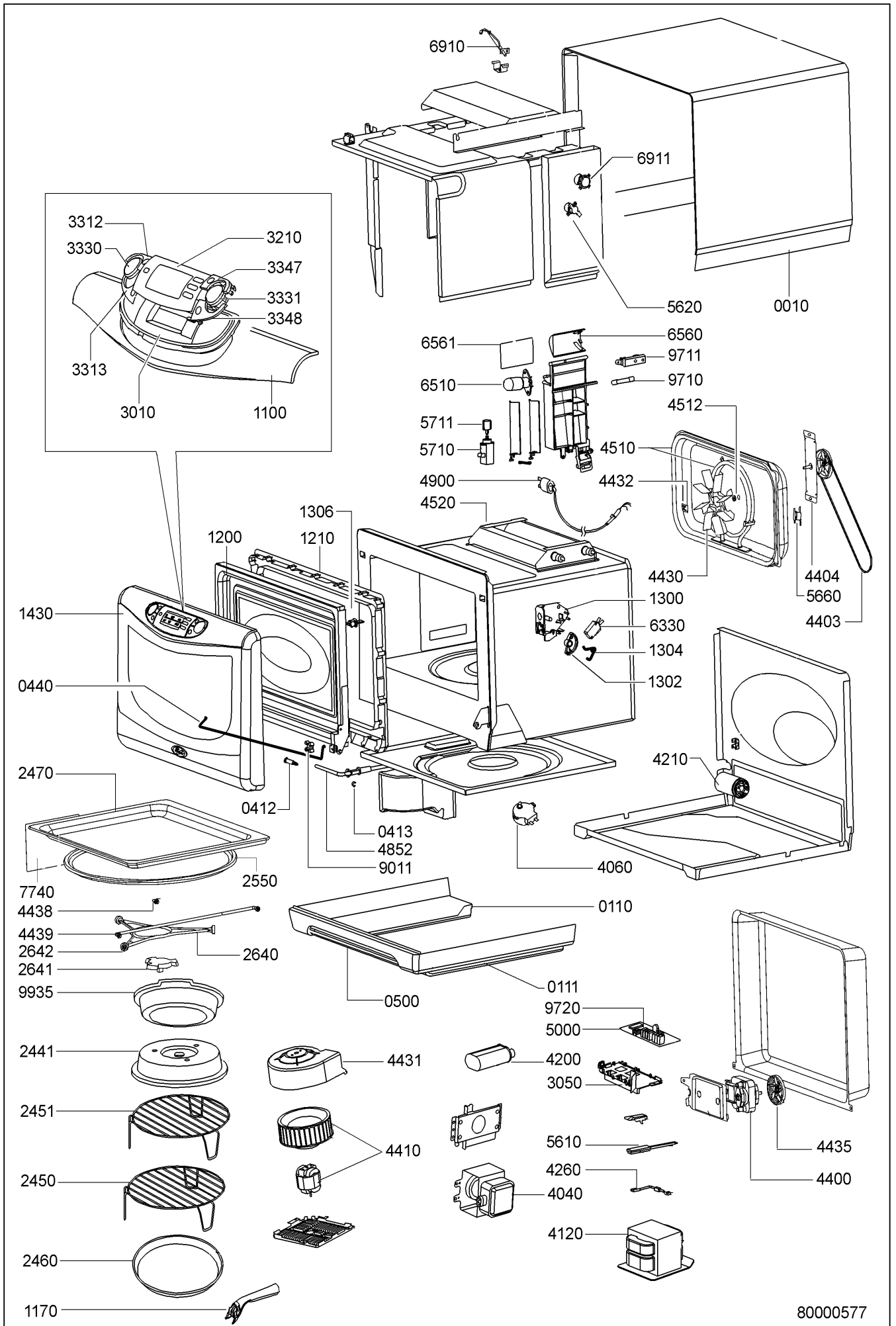

Wiring diagram

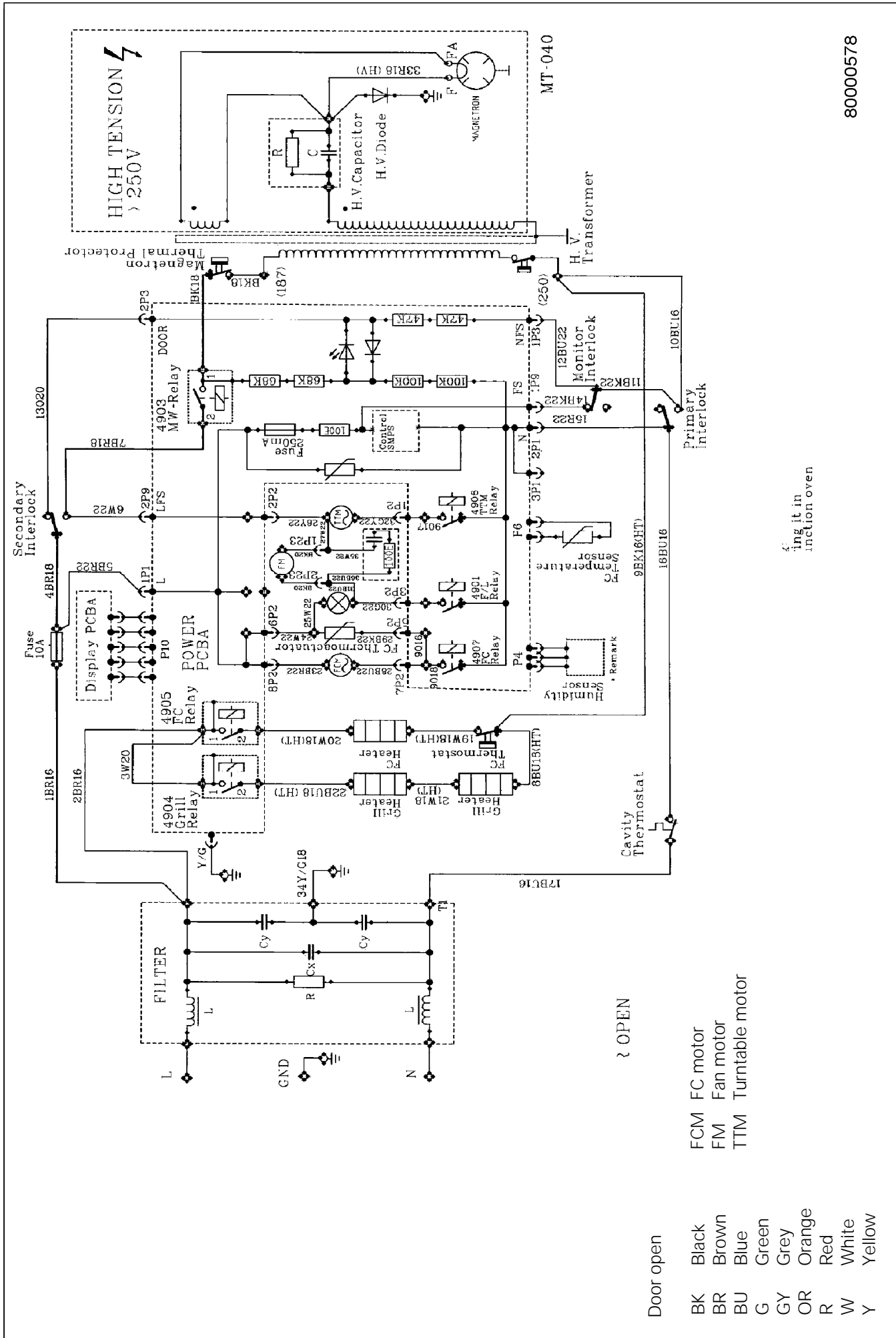

80000578

FC
 ing it in
 inction oven

? OPEN

- Door open
- BK Black
- BR Brown
- BU Blue
- G Green
- GY Grey
- OR Orange
- R Red
- W White
- Y Yellow
- FCM FC motor
- FM Fan motor
- TTM Turntable motor