

HCD-CP101

SERVICE MANUAL

Ver 1.4 2003.02

*US Model
Canadian Model
AEP Model
UK Model
E Model
Australian Model*



HCD-CP101 is the Amplifier, CD player, Tape Deck and Tuner section in CMT-CP101.

CD Section	Model Name Using Similar Mechanism	HCD-CP100
	CD Mechanism Type	CDM55F-K6BD41A
	Optical Pick-up Name	KSM-213DHAP
Tape deck Section	Model Name Using Similar Mechanism	NEW

SPECIFICATIONS

Amplifier section

AUDIO POWER SPECIFICATIONS

(US model only)

POWER OUTPUT AND TOTAL HARMONIC DISTORTION:

With 6-ohm loads, both channels driven, from 70 - 20,000 Hz; rated 18 watts per channel minimum RMS power, with no more than 0.9% total harmonic distortion from 250 milliwatts to rated output.

North American model:

Continuous RMS power output (reference):
35 + 35 W
(6 ohms at 1 kHz, 10% THD)

Total harmonic distortion less than 0.07% (6 ohms at 1 kHz, 18 W)

European model:

DIN power output (rated): 30 + 30 W
(6 ohms at 1 kHz, DIN)
Continuous RMS power output (reference):
35 + 35 W
(6 ohms at 1 kHz, 10% THD)

Music power output (reference):
85 + 85 W

Other models:

The following measured at 230 V AC, 60 Hz
DIN power output (rated): 27 + 27 W
(6 ohms at 1 kHz, DIN)
Continuous RMS power output (reference):
32 + 32 W
(6 ohms at 1 kHz, 10% THD)

The following measured at 220 V AC, 60 Hz
DIN power output (rated): 23 + 23 W
(6 ohms at 1 kHz, DIN)
Continuous RMS power output (reference):
26 + 26 W
(6 ohms at 1 kHz, 10% THD)

Inputs

AUDIO IN MD (VIDEO) (phono jacks):
Sensitivity 500/250 mV,
impedance 47 kilohms

Outputs

OPTICAL DIGITAL OUT (CD):
Optical
Accepts headphones with
an impedance of 8 ohms
or more
SPEAKER: 6 ohms

PHONES:

CD playersection

System Compact disc and digital audio system
Laser Semiconductor laser
($\lambda = 780 \text{ nm}$)
Emission duration: continuous
Wavelength 780 - 790 nm
Frequency response 2 Hz - 20 kHz ($\pm 0.5 \text{ dB}$)

Tape playersection

Recording system 4-track 2-channel stereo
Frequency response 50 - 13,000 Hz ($\pm 3 \text{ dB}$),
using a Sony TYPE I cassette

Tuner section

FM stereo, FM/AM superheterodyne tuner

FM tunersection

Tuning range
North American model: 87.5 - 108.0 MHz
(100-kHz step)
Other models: 87.5 - 108.0 MHz
(50-kHz step)
Antenna FM wire antenna
Antenna terminals 75 ohms unbalanced
Intermediate frequency 10.7 MHz

- Continued on next page -

COMPACT DISC DECK RECEIVER

AM tunersection

Tuning range	
Pan-American model:	530 - 1,710 kHz (with the tuning interval set at 10 kHz) 531 - 1,710 kHz (with the tuning interval set at 9 kHz)
European model:	530 - 1,710 kHz (with the tuning interval set at 9 kHz)
Other models:	530 - 1,710 kHz (with the tuning interval set at 10 kHz) 531 - 1,602 kHz (with the tuning interval set at 9 kHz)
Antenna	AM loop antenna, external antenna terminal
Intermediate frequency	450 kHz

General

Power requirements	
North American model:	120 V AC, 60 Hz
European model:	230 V AC, 50/60 Hz
Australian model:	230 V AC, 50/60 Hz
Mexican model:	120 V AC, 60 Hz
Korean model:	230 V AC, 50/60 Hz
Other models:	110 - 120 V or 220 - 240 V AC, 50/60 Hz Adjustable with voltage selector
Power consumption	
European model:	See the nameplate 0.5 W (in the standby mode)
Other models:	See the nameplate
Dimensions (w/h/d)	Approx. 190 × 252 × 340 mm incl. projecting parts and controls
Mass	Approx. 5.6 kg
Supplied accessories	Remote commander (1) AM loop antenna (1) FM wire antenna (1) Batteries (2)

Design and specifications are subject to change without notice.

Notes on chip component replacement

- Never reuse a disconnected chip component.
- Notice that the minus side of a tantalum capacitor may be damaged by heat.

Flexible Circuit Board Repairing

- Keep the temperature of the soldering iron around 270 °C during repairing.
- Do not touch the soldering iron on the same conductor of the circuit board (within 3 times).
- Be careful not to apply force on the conductor when soldering or unsoldering.

CAUTION

Use of controls or adjustments or performance of procedures other than those specified herein may result in hazardous radiation exposure.

This appliance is classified as a CLASS 1 LASER product. The CLASS 1 LASER PRODUCT MARKING is located on the rear exterior.

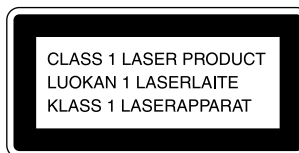

Laser component in this product is capable of emitting radiation exceeding the limit for Class 1.

SAFETY-RELATED COMPONENT WARNING!!

COMPONENTS IDENTIFIED BY MARK \triangle OR DOTTED LINE WITH MARK \triangle ON THE SCHEMATIC DIAGRAMS AND IN THE PARTS LIST ARE CRITICAL TO SAFE OPERATION. REPLACE THESE COMPONENTS WITH SONY PARTS WHOSE PART NUMBERS APPEAR AS SHOWN IN THIS MANUAL OR IN SUPPLEMENTS PUBLISHED BY SONY.

ATTENTION AU COMPOSANT AYANT RAPPORT À LA SÉCURITÉ!

LES COMPOSANTS IDENTIFIÉS PAR UNE MARQUE \triangle SUR LES DIAGRAMMES SCHÉMATIQUES ET LA LISTE DES PIÈCES SONT CRITIQUES POUR LA SÉCURITÉ DE FONCTIONNEMENT. NE REMPLACER CES COMPOSANTS QUE PAR DES PIÈCES SONY DONT LES NUMÉROS SONT DONNÉS DANS CE MANUEL OU DANS LES SUPPLÉMENTS PUBLIÉS PAR SONY.

SAFETY CHECK-OUT

After correcting the original service problem, perform the following safety check before releasing the set to the customer: Check the antenna terminals, metal trim, “metallized” knobs, screws, and all other exposed metal parts for AC leakage. Check leakage as described below.

LEAKAGE TEST

The AC leakage from any exposed metal part to earth ground and from all exposed metal parts to any exposed metal part having a return to chassis, must not exceed 0.5 mA (500 microamperes.). Leakage current can be measured by any one of three methods.

1. A commercial leakage tester, such as the Simpson 229 or RCA WT-540A. Follow the manufacturers’ instructions to use these instruments.
2. A battery-operated AC milliammeter. The Data Precision 245 digital multimeter is suitable for this job.
3. Measuring the voltage drop across a resistor by means of a VOM or battery-operated AC voltmeter. The “limit” indication is 0.75 V, so analog meters must have an accurate low-voltage scale. The Simpson 250 and Sanwa SH-63Trd are examples of a passive VOM that is suitable. Nearly all battery operated digital multimeters that have a 2 V AC range are suitable. (See Fig. A)

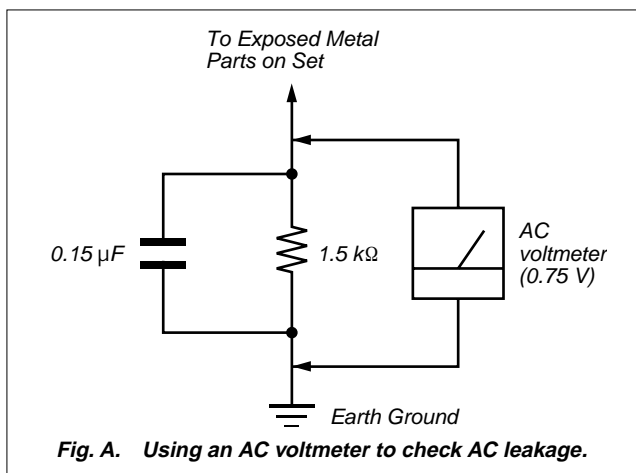

TABLE OF CONTENTS

1. SERVICING NOTES	4
2. GENERAL	
Location of Controls	5
Setting the Clock	6
3. DISASSEMBLY	
3-1. Disassembly Flow	7
3-2. Cover (Upper)	8
3-3. CD Lid Sub Assy	8
3-4. Front Panel Section	9
3-5. Tape Mechanism Deck	9
3-6. CD Mechanism Deck (CDM55F-K6BD41A)	10
3-7. Base Unit (BU-K6BD41A)	10
3-8. Motor Board	11
3-9. Cam (CDM55)	11
4. TEST MODE	12
5. ELECTRICAL ADJUSTMENTS	
Deck Section	13
CD Section	14
6. DIAGRAMS	
6-1. Block Diagram – CD Section –	15
6-2. Block Diagram – TUNER/TAPE DECK Section –	16
6-3. Block Diagram – MAIN Section –	17
6-4. Note for Printed Wiring Boards and Schematic Diagrams	18
6-5. Printed Wiring Board – CD Section –	20
6-6. Schematic Diagram – CD Section –	21
6-7. Printed Wiring Board – TAPE DECK Section –	22
6-8. Schematic Diagram – TAPE DECK Section –	23
6-9. Printed Wiring Boards – MAIN Section –	24
6-10. Schematic Diagram – MAIN Section (1/3) –	25
6-11. Schematic Diagram – MAIN Section (2/3) –	26
6-12. Schematic Diagram – MAIN Section (3/3) –	27
6-13. Printed Wiring Boards – CONTROL Section –	28
6-14. Schematic Diagram – CONTROL Section –	29
6-15. Printed Wiring Board – POWER Section (US, Canadian, Mexican models) –	30
6-16. Printed Wiring Board – POWER Section (Except US, Canadian, Mexican models) –	30
6-17. Schematic Diagram – POWER Section –	31
6-18. IC Pin Function Description	34
7. EXPLODED VIEWS	
7-1. Cover Section	36
7-2. Front Panel Section	37
7-3. Chassis Section	38
7-4. CD Mechanism Deck (CDM55F-K6BD41A)	39
7-5. Base Unit (BU-K6BD41A)	40
8. ELECTRICAL PARTS LIST	41

SECTION 1 SERVICING NOTES

NOTES ON HANDLING THE OPTICAL PICK-UP BLOCK OR BASE UNIT

The laser diode in the optical pick-up block may suffer electrostatic break-down because of the potential difference generated by the charged electrostatic load, etc. on clothing and the human body.

During repair, pay attention to electrostatic break-down and also use the procedure in the printed matter which is included in the repair parts.

The flexible board is easily damaged and should be handled with care.

NOTES ON LASER DIODE EMISSION CHECK

The laser beam on this model is concentrated so as to be focused on the disc reflective surface by the objective lens in the optical pick-up block. Therefore, when checking the laser diode emission, observe from more than 30 cm away from the objective lens.

• MODEL IDENTIFICATION

– Rear Panel –

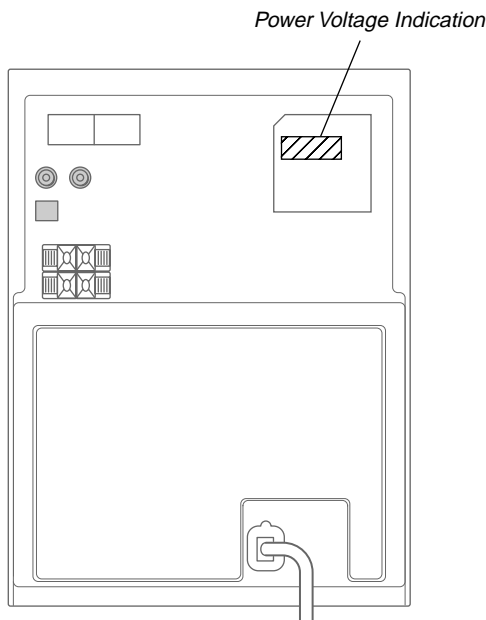

SERVICE POSITION

In checking the CD block, prepare jig (extension cable J-2501-011-B: 1.25 mm Pitch, 19 cores, Length 300 mm).

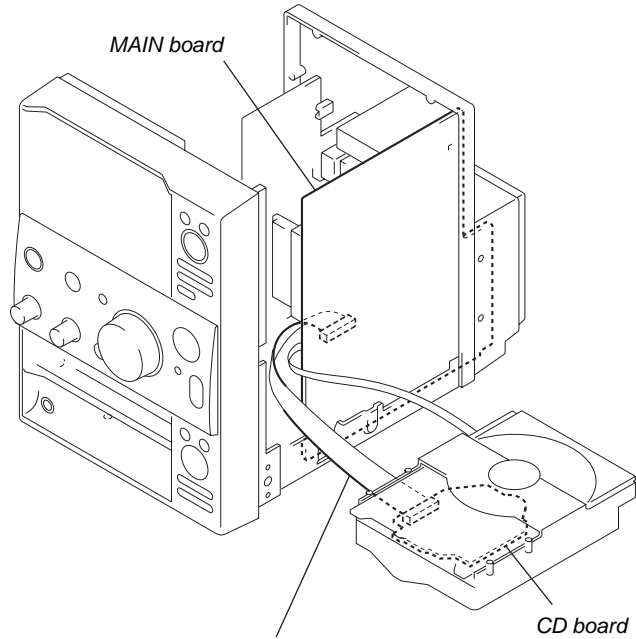

Connect jig (extension cable J-2501-011-B) to the MAIN board (CN101) and CD board (CN101).

Model	Power Voltage Indication
US, Canadian and Mexican models	AC: 120 V 60 Hz 75 W
AEP, UK, Korean and Australian models	AC: 230 V ~50/60 Hz 75 W
E, Singapore and Argentina models	AC: 110 – 120/ 220 – 240 V / 50/60 Hz 75 W

SECTION 2 GENERAL

This section is extracted from instruction manual.

• LOCATION OF CONTROLS

– Front View –

- | | | |
|--------------------------------------|-----------------------------------|--------------------------------------|
| BASS 23 (15) | TAPE EJECT ▲ 6 (12) | I/⏻ (power) 1 (7, 10, 15, 17) |
| CD EJECT ▲ 15 (8) | TAPE ● REC 5 (13) | |
| CD SYNC 11 (13, 14) | TAPE ◀▶ 8 (12–14) | |
| CD ▶▶ 17 (8, 9) | TAPE 10 (12–14) | |
| CD ■ 16 (8–10, 18, 20) | TAPE ■ 7 (12–14, 20) | |
| CD ◀◀/▶▶ 18 (8, 9) | TAPE ◀◀/▶▶ 9 (12) | |
| CD ◀◀/▶▶ 18 (8) | TREBLE 22 (15) | |
| DSG 3 (15) | TUNER BAND 12 (9, 10, 20) | |
| FUNCTION 2 (8–10, 12, 13, 18) | TUNING MODE 14 (9–11) | |
| PHONES jack 24 | TUNING +/- 13 (9–11) | |
| PLAY MODE 20 (8, 9, 14) | VOLUME 4 (17) | |
| Remote sensor 21 | | |
| REPEAT 19 (8) | | |

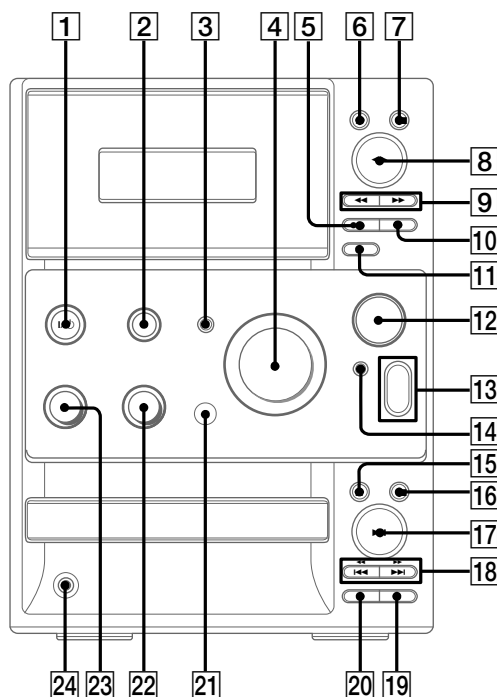

– Remote Control –

- | | | |
|---------------------------------------|--|--|
| CD REPEAT 18 (8) | SLEEP 14 (16) | 4 (8, 12–14) |
| CD ▶▶ 22 (8, 9) | TAPE ◀▶ 20 (12–14) | ■ 5 (8, 9, 12–14) |
| DIR MODE 19 (12–14) | TIMER SELECT 12 (15, 17) | ◀◀/▶▶ 6 (7–10, 14, 15, 17) |
| DISPLAY 2 (11, 16) | TIMER SET 15 (7, 14, 17) | ◀◀/▶▶ 7 (8, 10–12) |
| DSG 1 (15) | TUNER/BAND 21 (10) | I/⏻ (power) 3 (7, 15, 17) |
| ENTER 13 (7, 10, 15, 17) | TUNING MODE/PLAY MODE 10 (8, 9, 10, 11, 14) | ● REC 8 (13) |
| FM MODE 9 (11) | VOL +/- 11 (17) | |
| FUNCTION 17 (8–10, 12, 13, 18) | | |
| MEMORY 16 (10) | | |

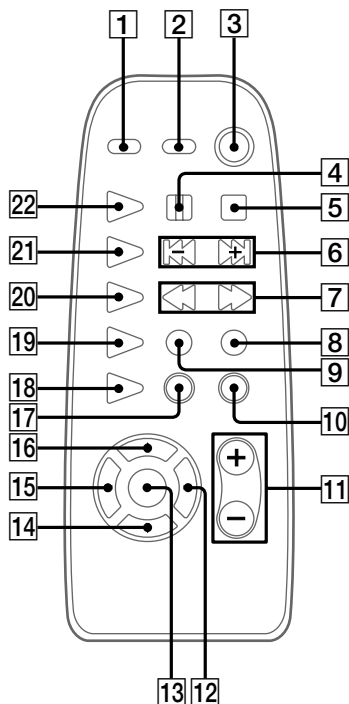

Setting the clock

- 1** Turn on the system.
- 2** Press **TIMER SET** on the remote.
- 3** Press **◀◀/▶▶** on the remote repeatedly to set the hour.
- 4** Press **ENTER** on the remote.
The minute indication flashes.
- 5** Press **◀◀/▶▶** on the remote repeatedly to set the minute.
- 6** Press **ENTER** on the remote.
The clock will begin operating.

To adjust the clock

- 1** Press **TIMER SET** on the remote.
- 2** Press **◀◀** or **▶▶** on the remote to select "SET CLOCK", then press **ENTER** on the remote.
- 3** Do the same procedures as step 3 to 6 above.

SECTION 3 DISASSEMBLY

- This set can be disassembled in the order shown below.

3-1. DISASSEMBLY FLOW

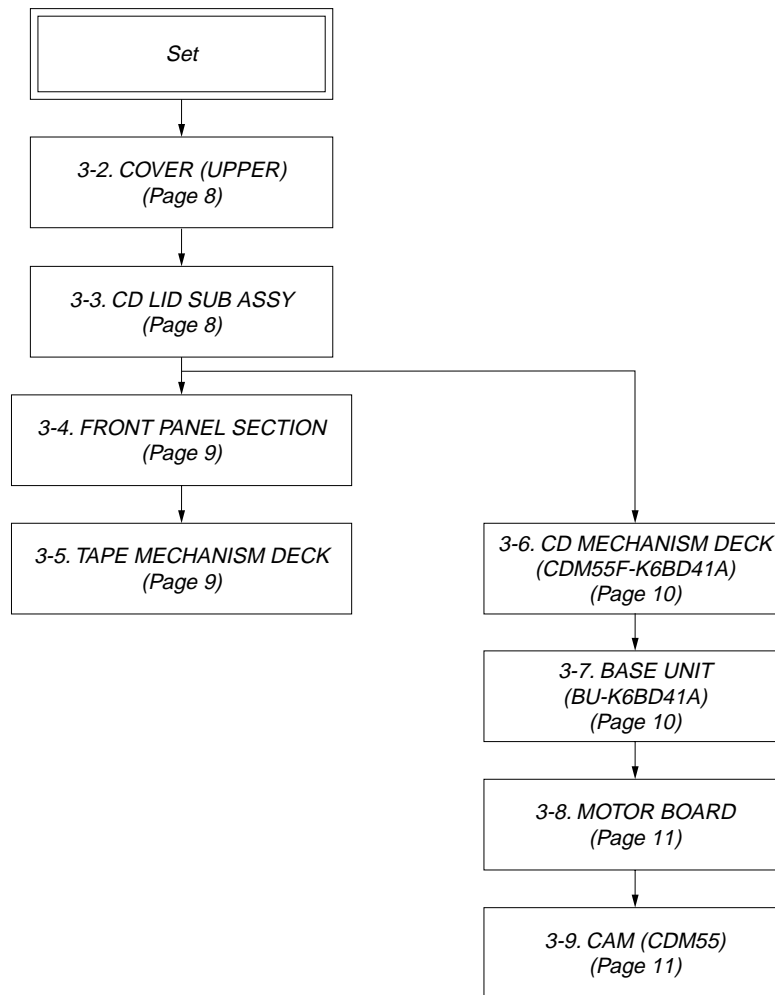

HCD-CP101

Note: Follow the disassembly procedure in the numerical order given.

3-2. COVER (UPPER)

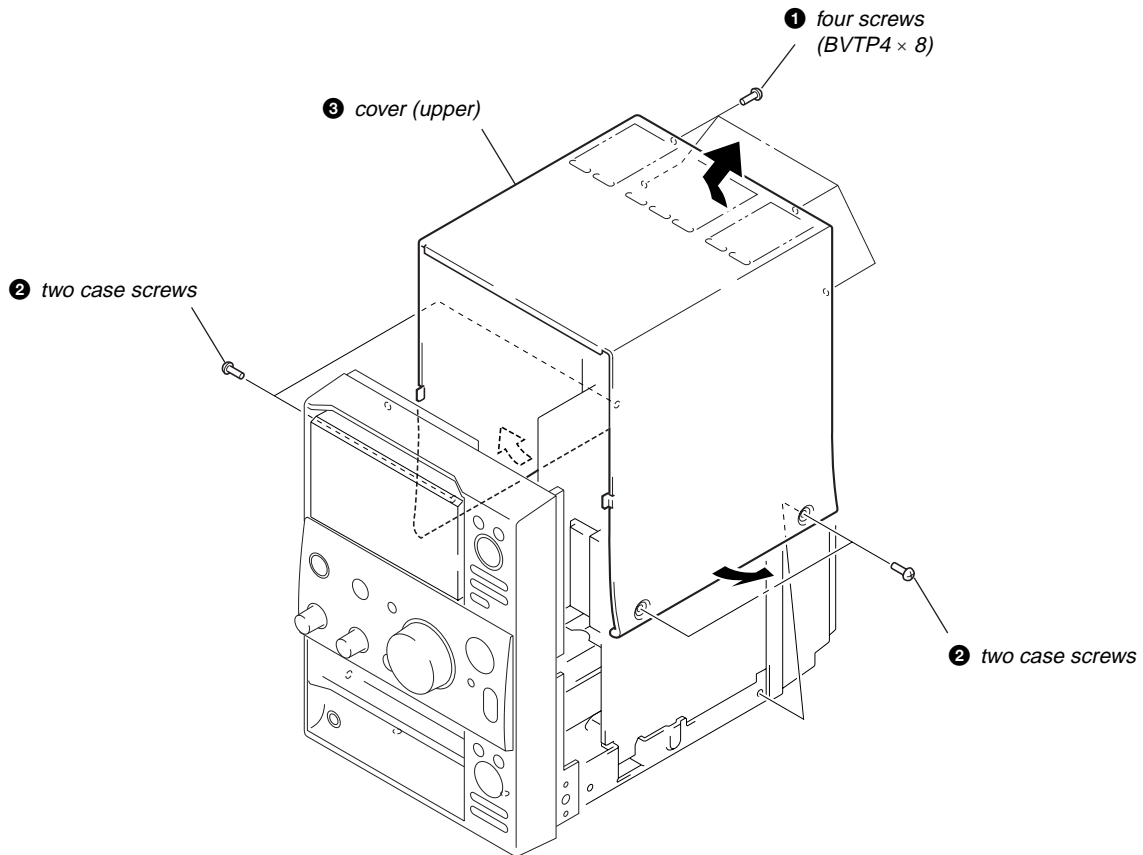

3-3. CD LID SUB ASSY

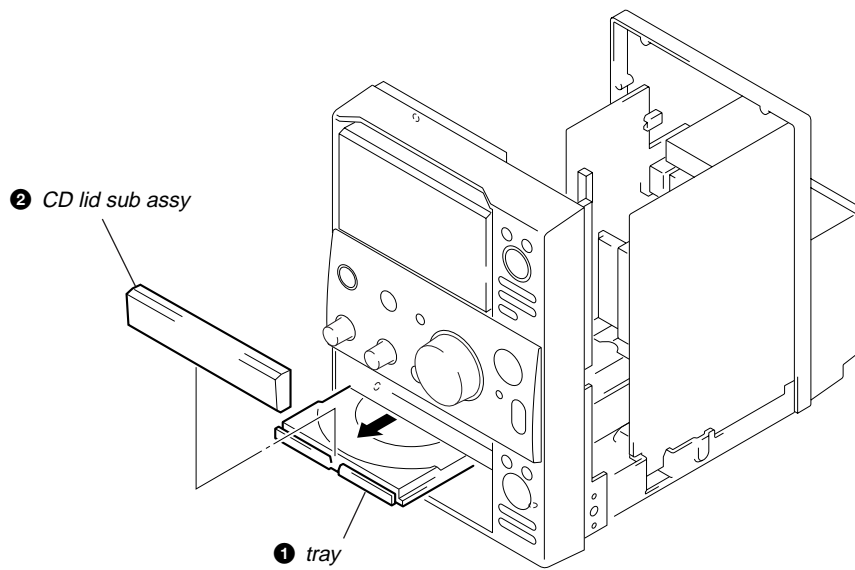

Note: Open the tray by supplying the power.

3-4. FRONT PANEL SECTION

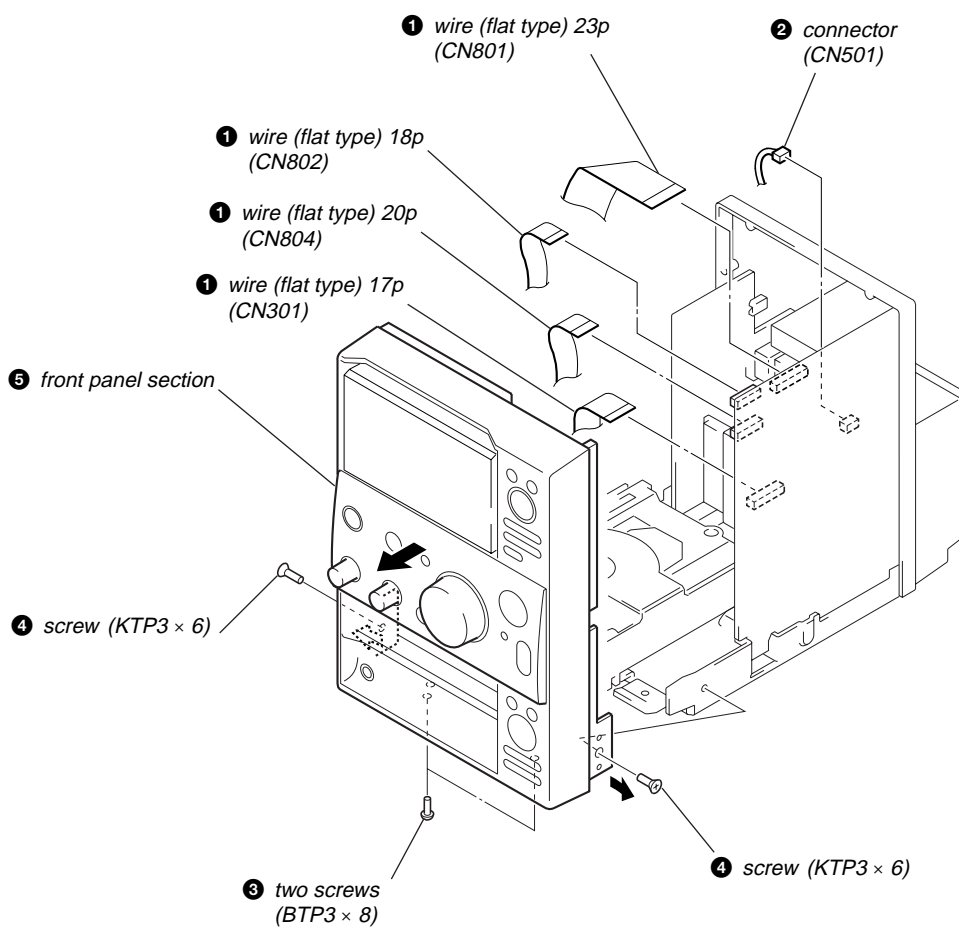

3-5. TAPE MECHANISM DECK

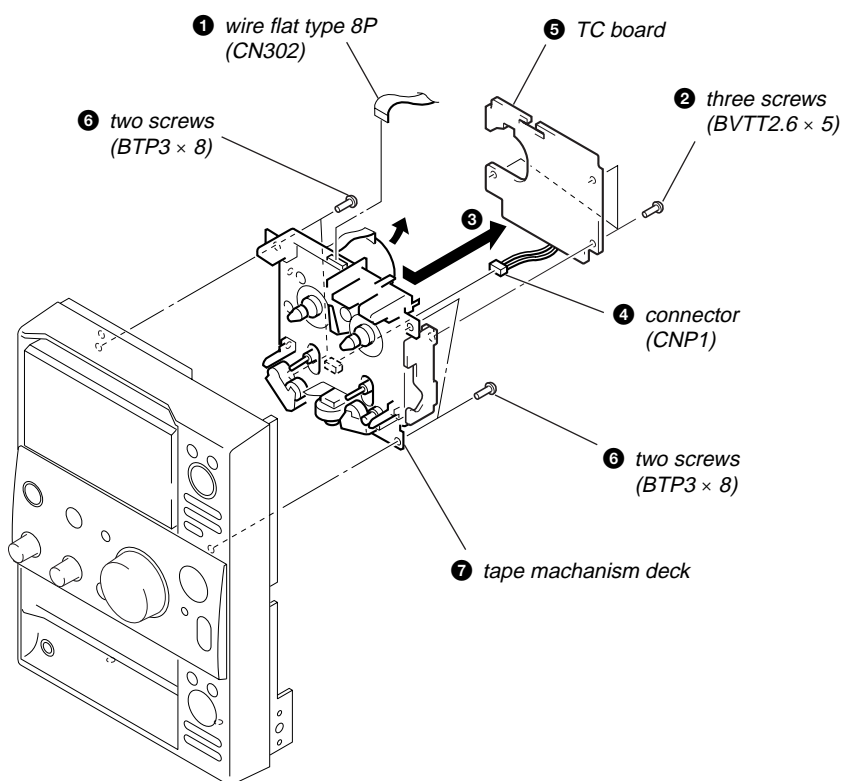

3-6. CD MECHANISM DECK (CDM55F-K6BD41A)

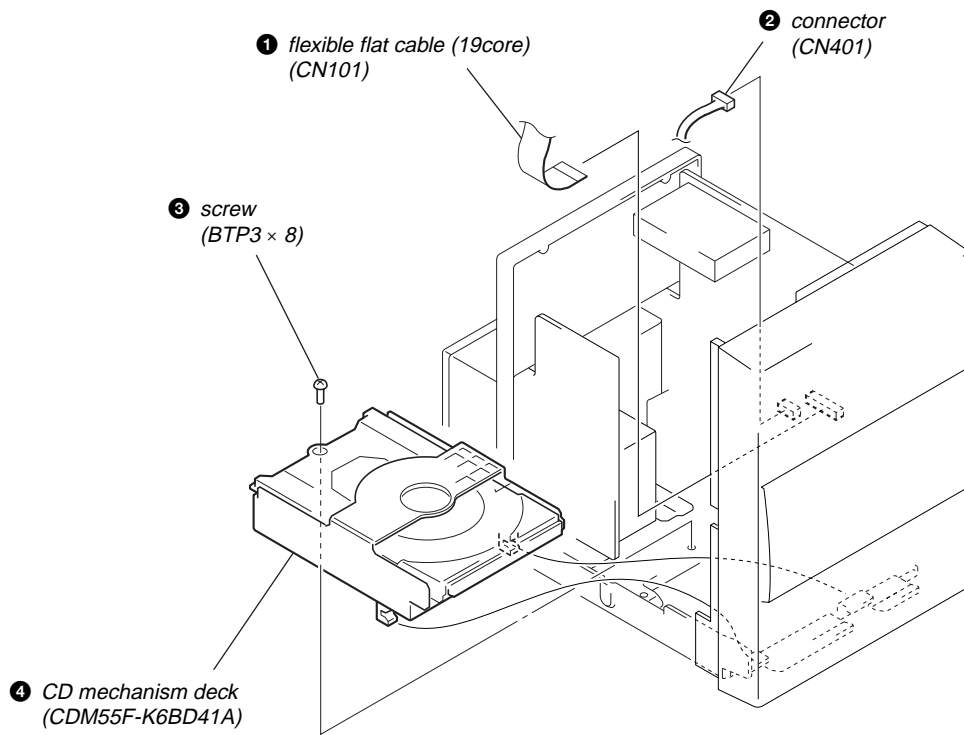

3-7. BASE UNIT (BU-K6BD41A)

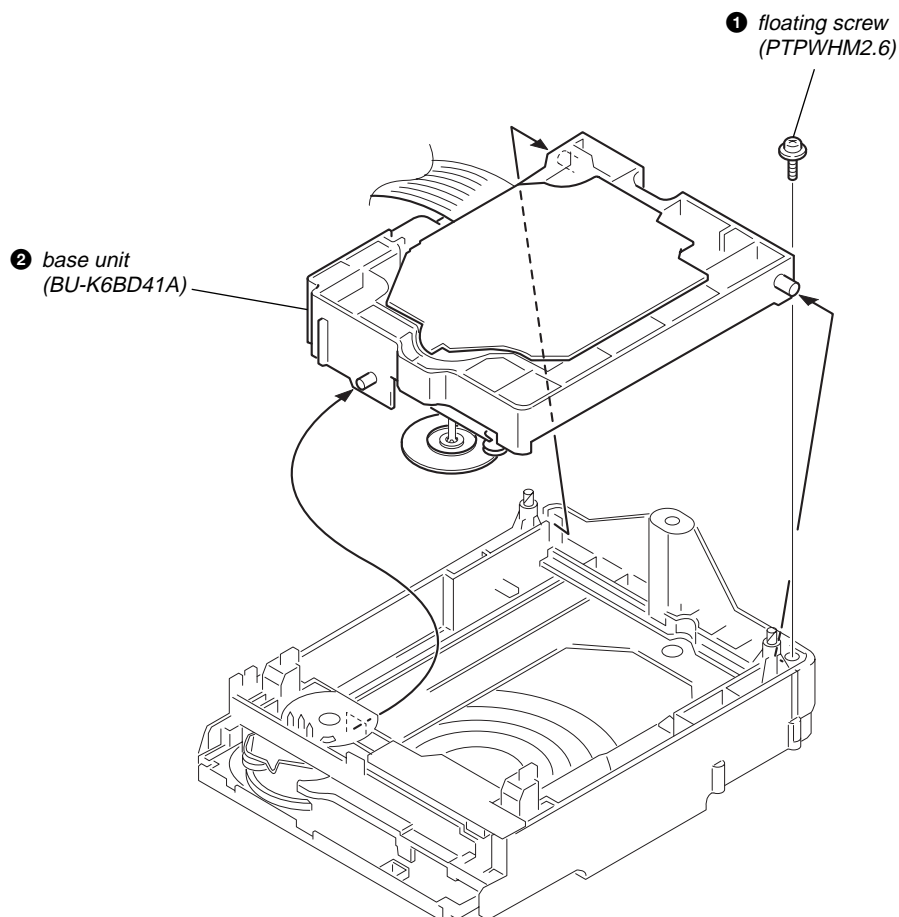

3-8. MOTOR BOARD

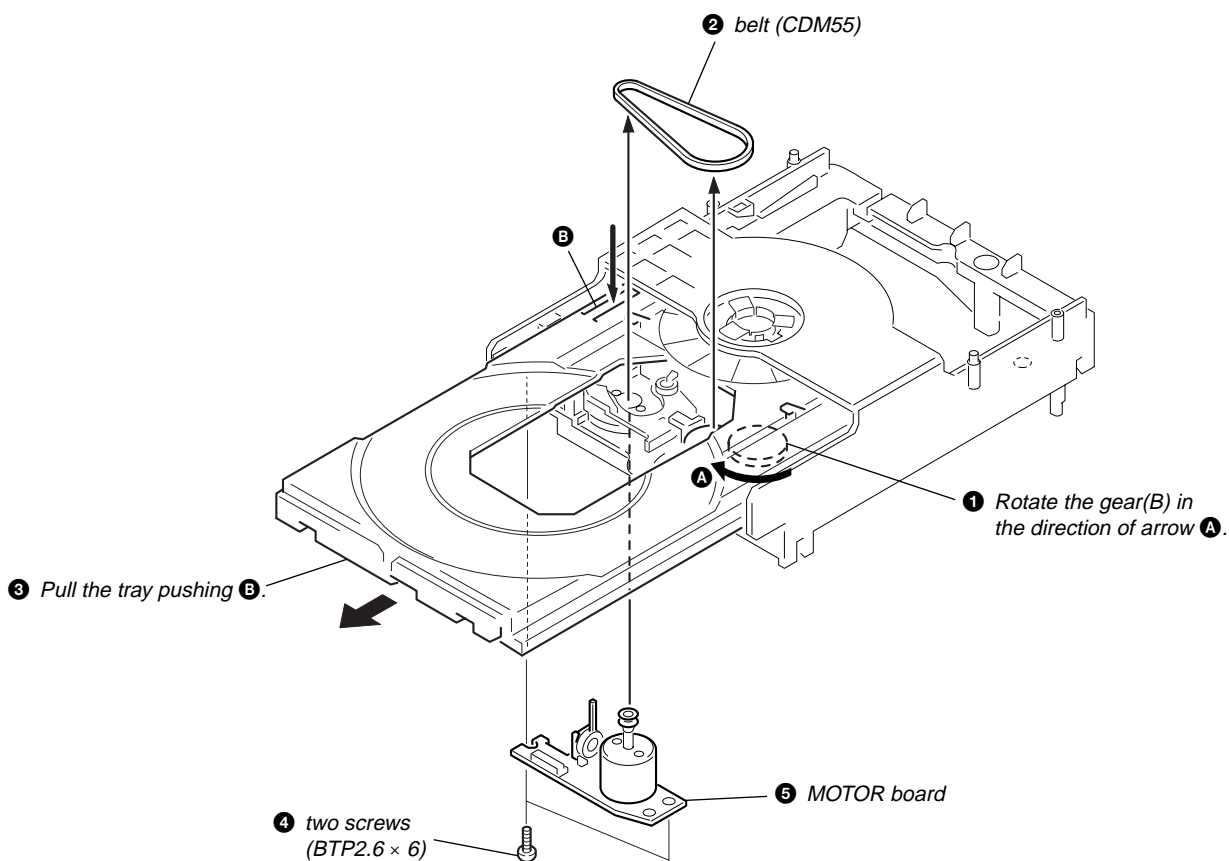

3-9. CAM (CDM55)

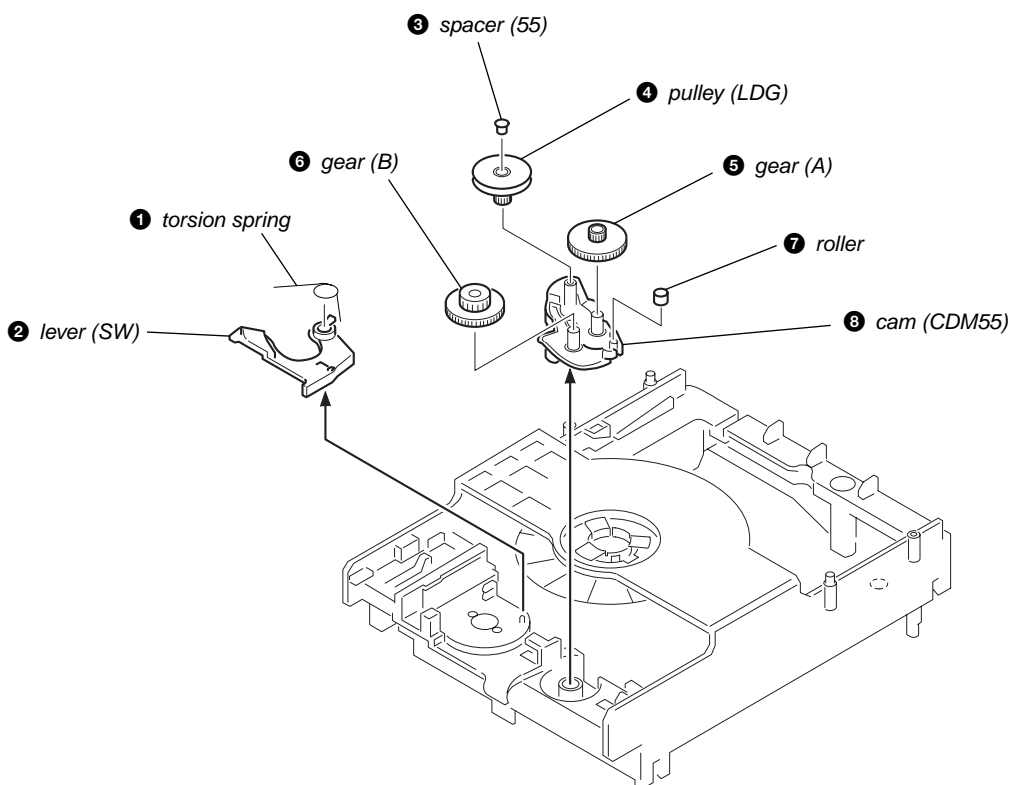

SECTION 4 TEST MODE

[COLD RESET]

- The cold reset clears all data including preset data stored in the RAM to initial conditions. Execute this mode when returning the set to the customer.

Procedure:

- Turn ON the power.
- Press three buttons of **[TAPE]**, **[CD]**, and **[BAND]** simultaneously.
- The set is reset.

[LIQUID CRYSTAL DISPLAY ALL LIT CHECK MODE]

Procedure:

- Set to standby state.
- Press three buttons of **[TAPE]**, **[CD]**, and **[TUNING MODE]** simultaneously.
- Liquid crystal display are all turned on.
- To exit from this mode, press the **[I/O]** button to turn the power OFF.

[TAPE DECK AGING MODE]

This mode can be used for operation check of tape deck section.

Procedure:

- Set a tape in the tape deck.
- Set to standby state.
- Press three buttons of **[TAPE]**, **[CD]**, and **[TUNING +]** simultaneously.
- The aging is executed in bellow sequence.
- To exit from the aging mode, press the **[I/O]** button to turn the power OFF.

Aging mode sequence:

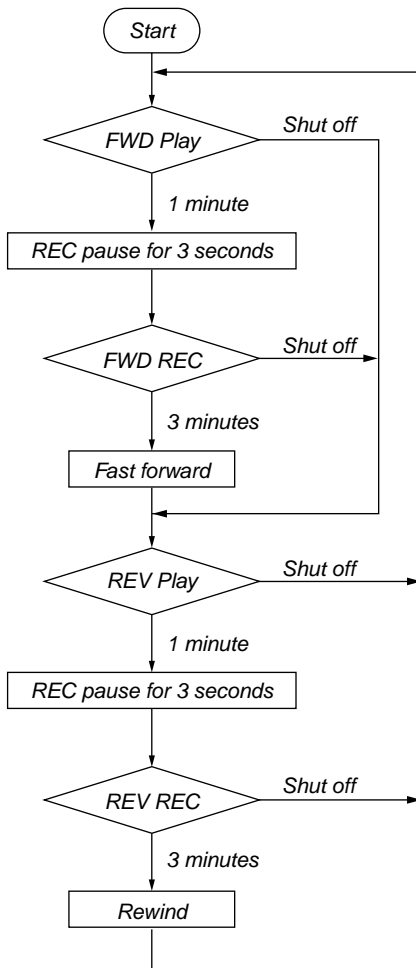

[CD AGING MODE]

This mode can be used for operation check of CD section.

Procedure:

- Load a CD disc.
- Set to standby state.
- Press three buttons of **[TAPE]**, **[CD]**, and **[TUNING -]** simultaneously.
- The aging is executed in bellow sequence.
- To exit from the aging mode, press the **[I/O]** button to turn the power OFF.

Aging mode sequence:

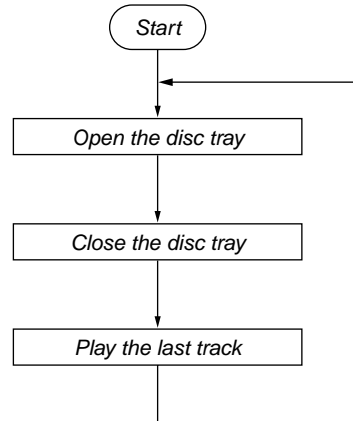

[CHANGE-OVER MD/VIDEO]

Procedure:

- Set to standby state.
- Press the **[CD]** and the **[FUNCTION]** buttons simultaneously.
The function changes over to MD or VIDEO by turns.

[CHANGE-OVER THE AM TUNING INTERVAL (EXCEPT AEP and UK models)]

- The AM tuning interval can be changed over 9 kHz or 10 kHz.

Procedure:

- Press the **[I/O]** button to turn the power ON.
- Select the function "TUNER", and press the **[BAND]** button to select the BAND "AM".
- Press the **[I/O]** button to turn the power OFF.
- Change over to 9 kHz:
Press the **[TUNING -]** and the **[CD]** buttons simultaneously.
Change over to 10 kHz:
Press the **[TUNING +]** and the **[CD]** buttons simultaneously.

SECTION 5 ELECTRICAL ADJUSTMENTS

DECK SECTION

0 dB=0.775 V

Note: Confirm each contents of this section first of all. If the results are not satisfied, do the adjustment.

1. The adjustments should be performed with the rated power supply voltage unless otherwise noted.
2. The adjustments should be performed in the order given in this service manual. (As a general rule, playback circuit adjustment should be completed before performing recording circuit adjustment.)
3. The adjustments should be performed for both L-CH and R-CH.

REC BIAS ADJUSTMENT

Procedure:

1. Mode: REC
FUNCTION: VIDEO

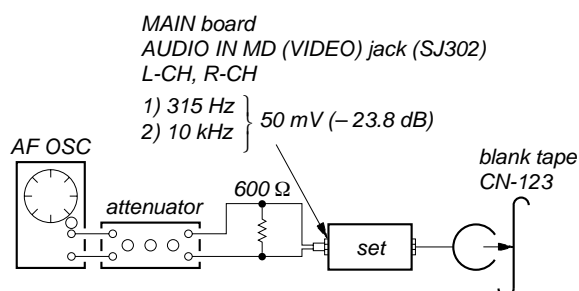

2. Mode: Playback

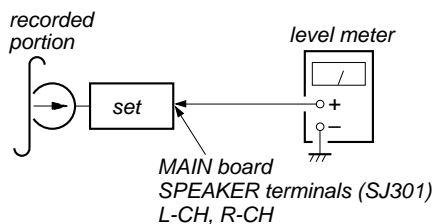

3. Confirm playback the signal recorded in step 1 become specified values as follows.
If these values are out of specification values, adjust the RV101 (L-CH) and RV201 (R-CH) on the TC board to repeat steps 1 and 2.

Specified values: Playback output of 315 Hz to playback output of 10 kHz: ± 0.5 dB

Adjustment Location:

- TC BOARD (Component Side) -

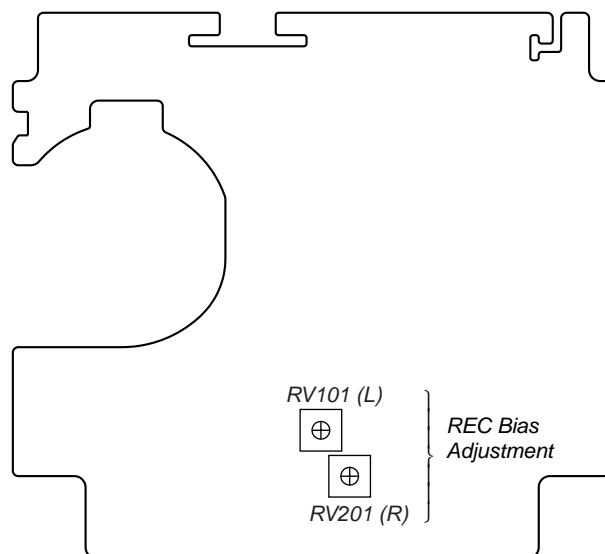

CD SECTION

Note:

1. CD Block is basically constructed to operate without adjustment.
2. Use YEDS-18 disc (3-702-101-01) unless otherwise indicated.
3. Use an oscilloscope with more than 10 MΩ impedance.
4. Clean the object lens by an applicator with neutral detergent when the signal level is low than specified value with the following checks.
5. Check the focus bias check when optical block is replaced.

FOCUS BIAS CHECK

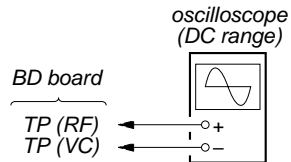

Procedure :

1. Connect oscilloscope to TP (RF) and TP (VC) on the CD board.
2. Press the button to turn the power on, and press the (CD) button to open the CD disc tray.
3. Put disc (YEDS-18) in and press the (CD) button to play-back.
4. Confirm that oscilloscope waveform is as shown in the figure below. (eye pattern)

A good eye pattern means that the diamond shape (◇) in the center of the waveform can be clearly distinguished.

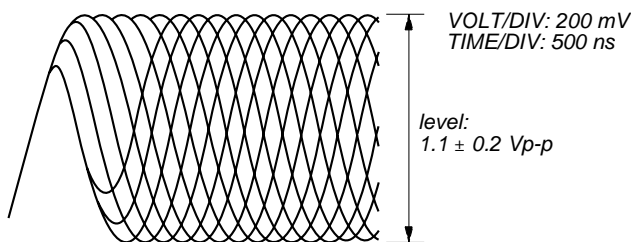

Checking Location:

– CD BOARD (Conductor Side) –

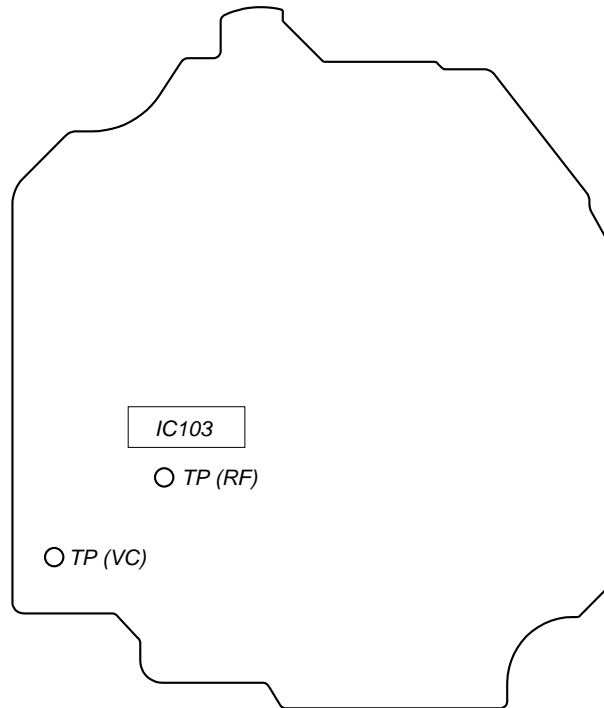

SECTION 6
DIAGRAMS

6-1. BLOCK DIAGRAM – CD Section –

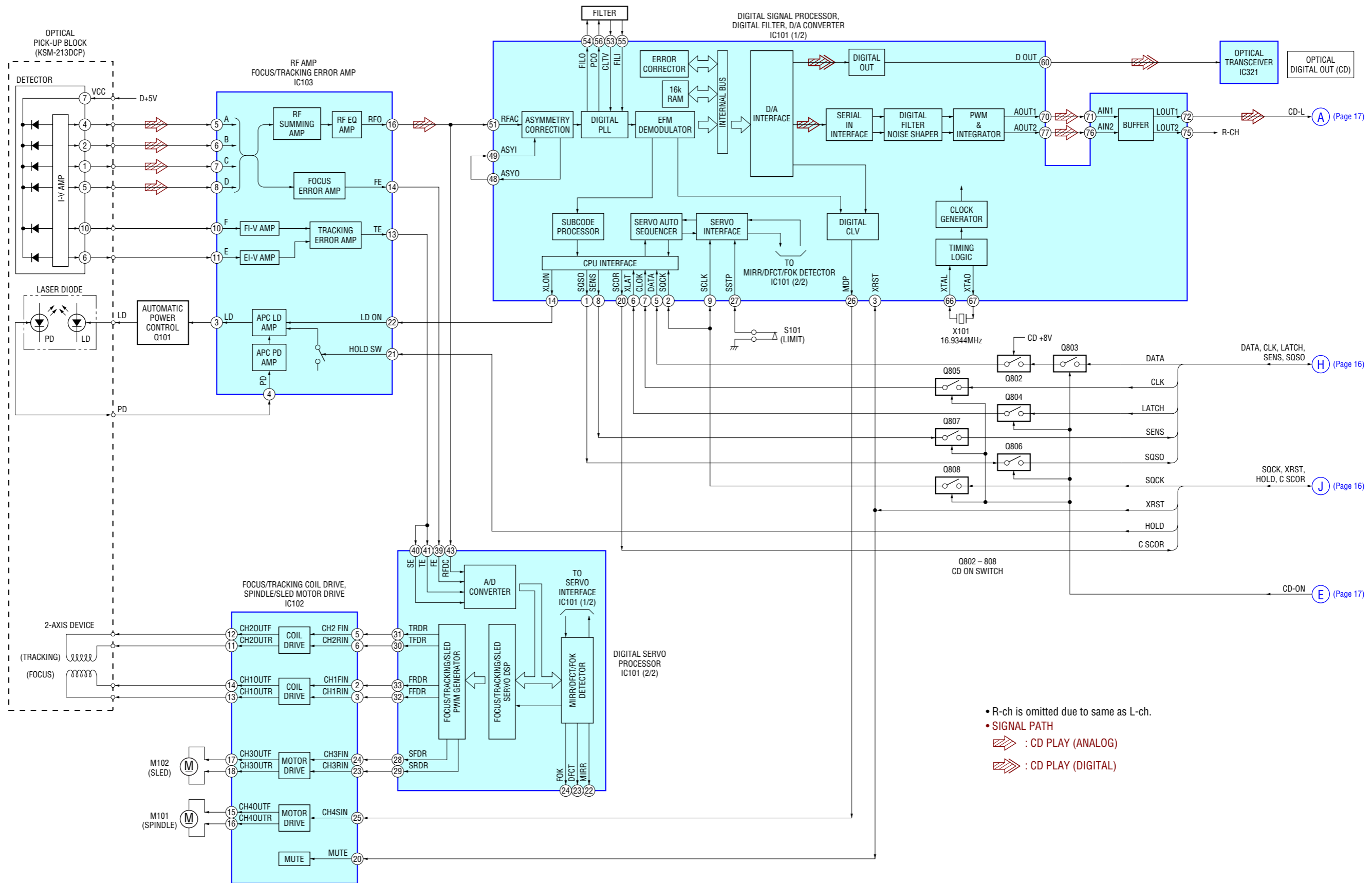

6-2. BLOCK DIAGRAM – TUNER/TAPE DECK Section –

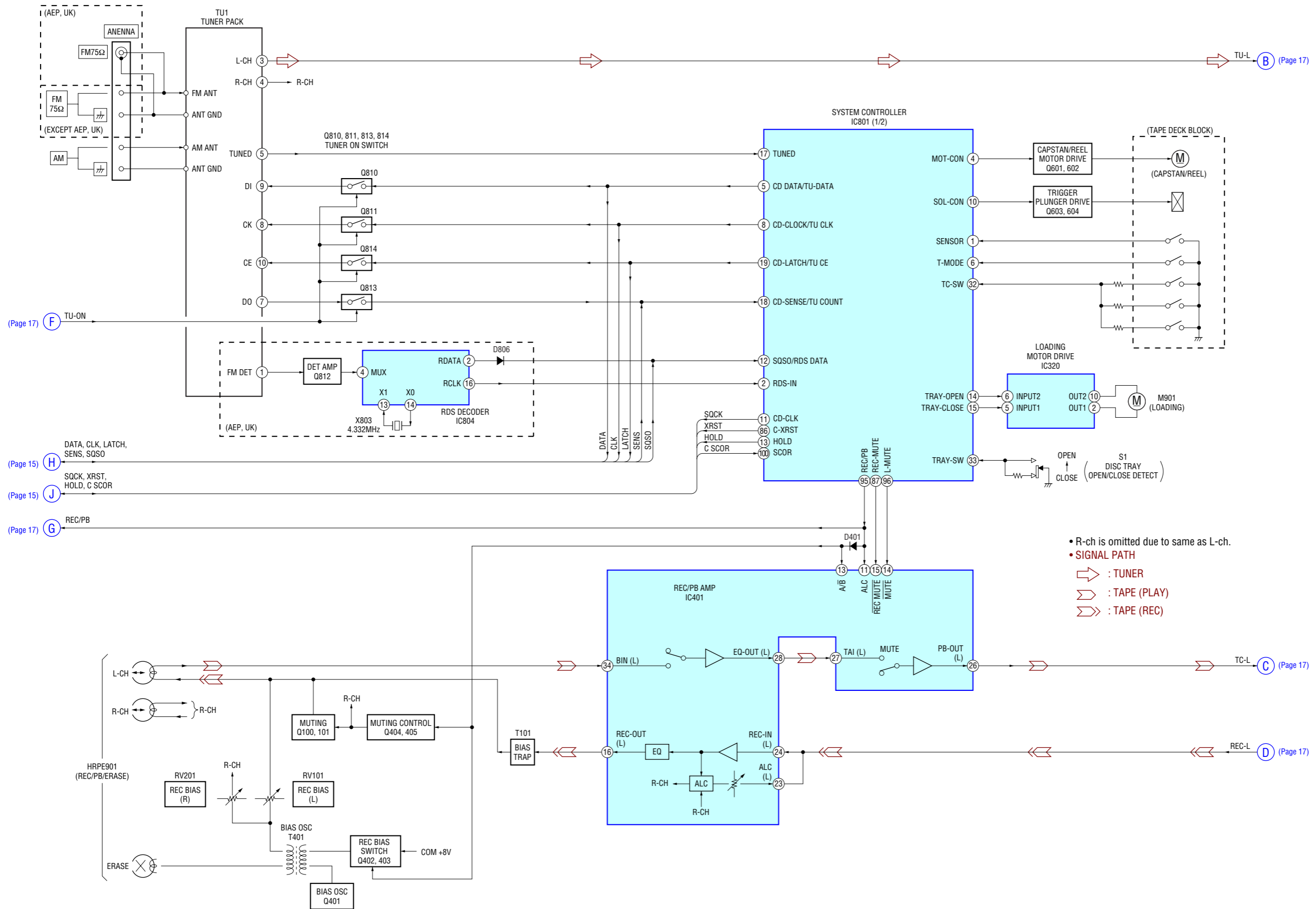

6-3. BLOCK DIAGRAM – MAIN Section –

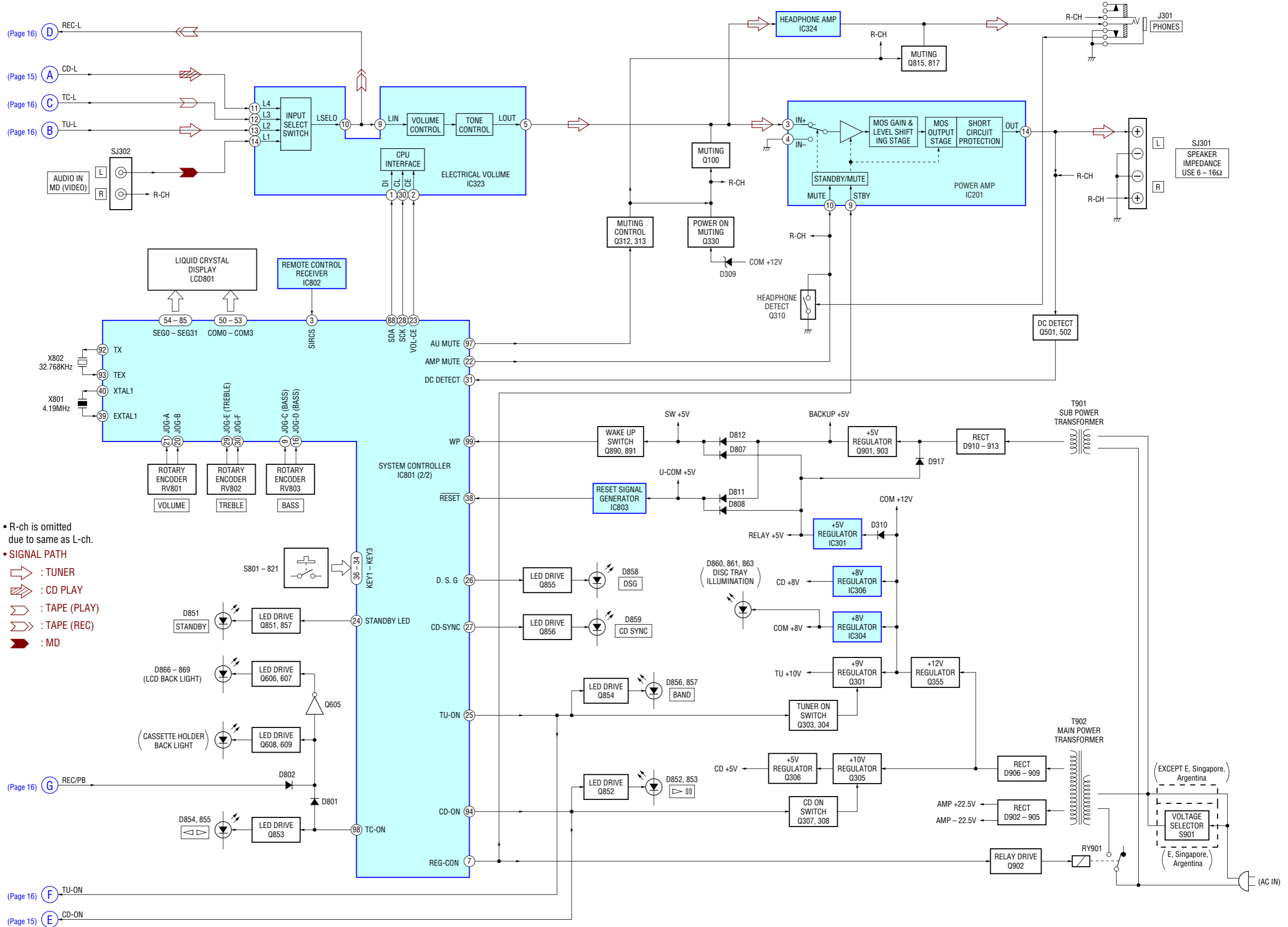

6-4. NOTE FOR PRINTED WIRING BOARDS AND SCHEMATIC DIAGRAMS

Note on Printed Wiring Boards:

- : parts extracted from the component side.
- : parts extracted from the conductor side.
- : indicates side identified with part number.
- △ : internal component.
- : Pattern from the side which enables seeing.
(The other layers' patterns are not indicated.)

Caution:
 Pattern face side: Parts on the pattern face side seen from
 (Conductor Side) the pattern face are indicated.
 Parts face side: Parts on the parts face side seen from
 (Component Side) the parts face are indicated.

Note on Schematic Diagram:

- All capacitors are in μF unless otherwise noted. pF : $\mu\mu\text{F}$
50 WV or less are not indicated except for electrolytics
and tantalums.
- All resistors are in Ω and $1/4\text{W}$ or less unless otherwise
specified.
- △ : internal component.
- : panel designation.

Note:
 The components identi-
 fied by mark △ or dotted
 line with mark △ are criti-
 cal for safety.
 Replace only with part
 number specified.

Note:
 Les composants identifiés par
 une marque △ sont critiques
 pour la sécurité.
 Ne les remplacer que par une
 pièce portant le numéro
 spécifié.

- : B+ Line.
- - - : B- Line.
- Voltages are taken with a VOM (Input impedance 10 M Ω).
Voltage variations may be noted due to normal produc-
tion tolerances.
- Waveforms are taken with a oscilloscope.
Voltage variations may be noted due to normal produc-
tion tolerances.
- Circled numbers refer to waveforms.
- Signal path.
- ⇨ : TUNER
- ⇨ : TAPE (PLAY)
- ⇨ : TAPE (REC)
- ⇨ : MD
- ⇨ : CD PLAY (ANALOG)
- ⇨ : CD PLAY (DIGITAL OUT)
- Abbreviation
- AR : Argentina model
- AUS : Australian model
- CND : Canadian model
- KR : Korean model
- MX : Mexican model
- SP : Singapore model

• Circuit Boards Location

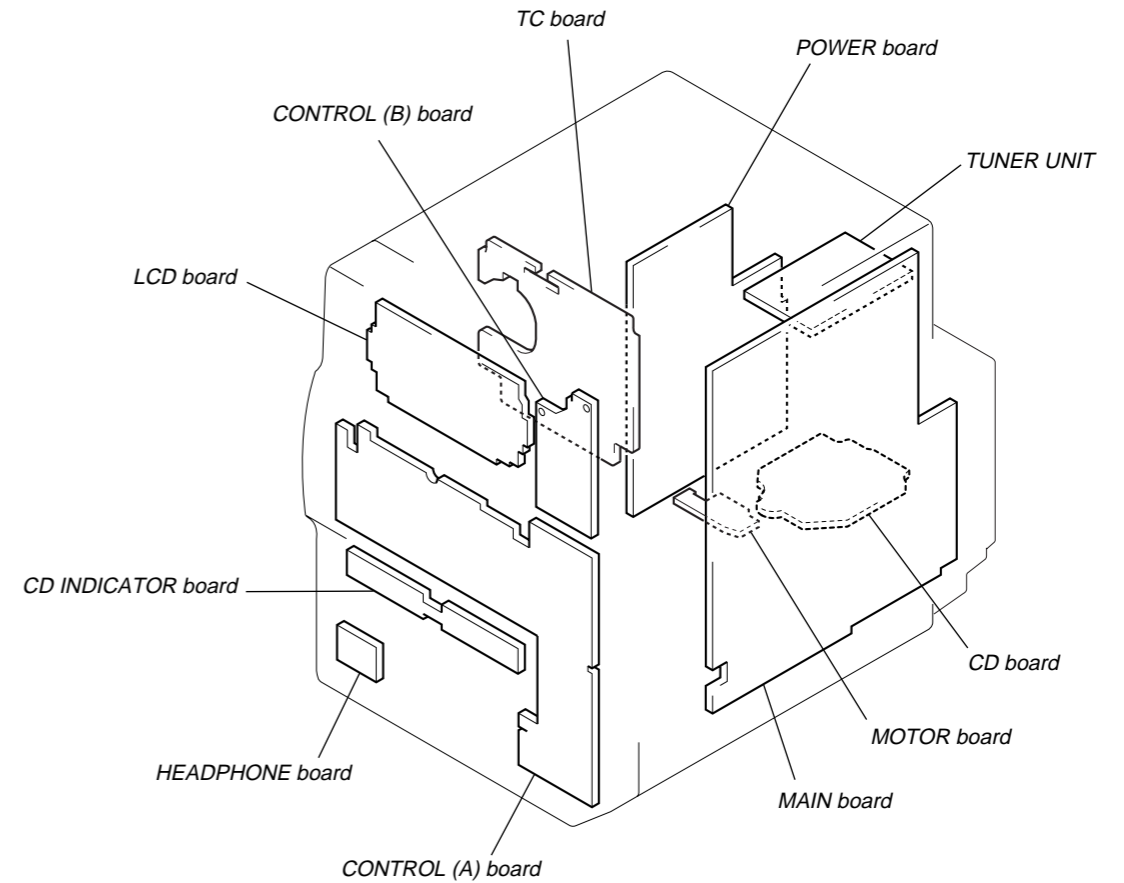

• Waveforms
– CD Board –

1 IC103 16 (RFO) (CD Play Mode)

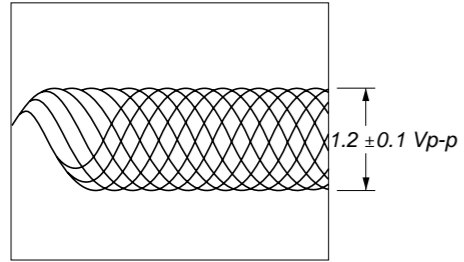

6 IC101 20 (SCOR) (CD Play Mode)

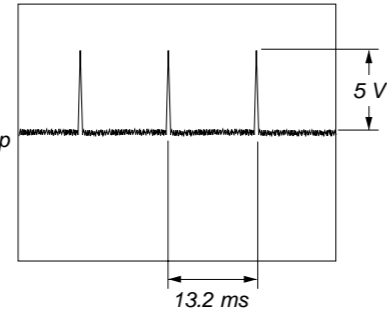

2 IC103 14 (FE) (CD Play Mode)

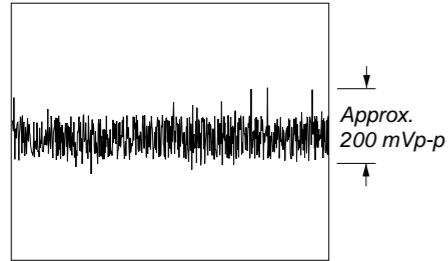

7 IC101 06 (XTAI)

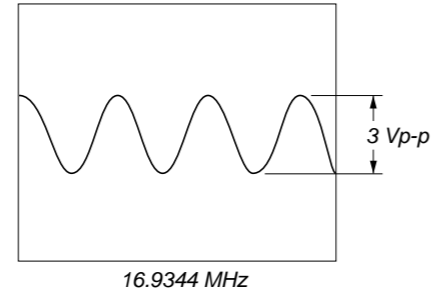

3 IC103 13 (TE) (CD Play Mode)

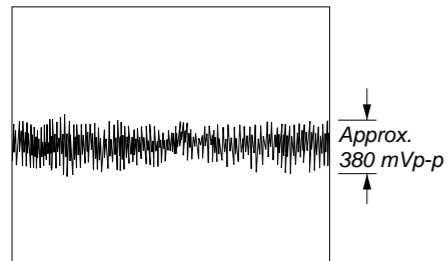

4 IC101 15 (WFCK)

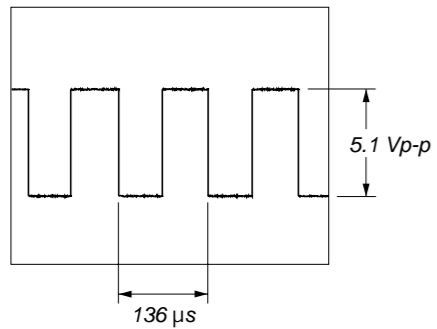

5 IC101 17 (XPCK)

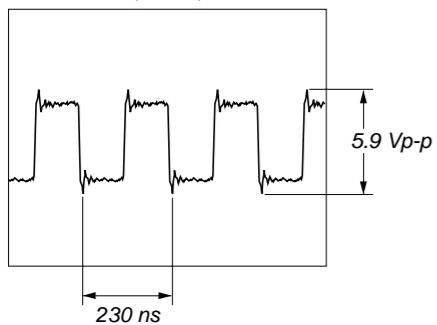

– TC Board –

11 T401 (REC Mode)

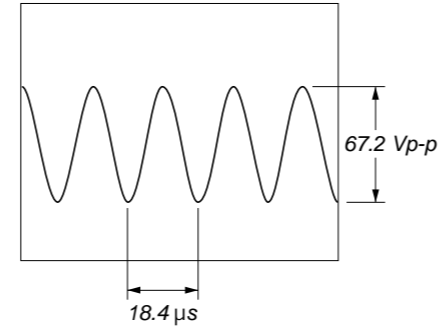

12 Q401 Collector (REC Mode)

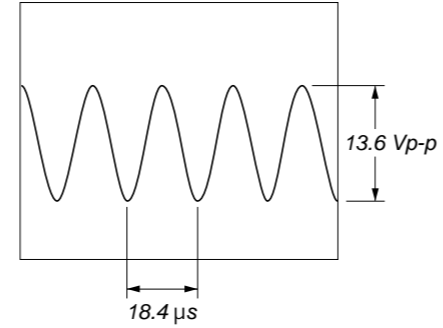

18 T101, 201 (REC Mode)

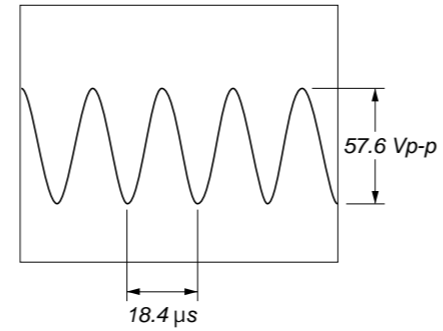

– MAIN Board –

21 IC804 14 (XO) (AEP, UK only)

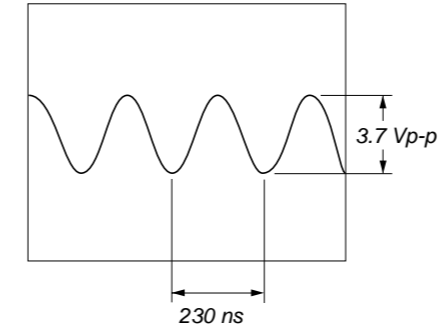

22 IC801 10 (XTAL1)

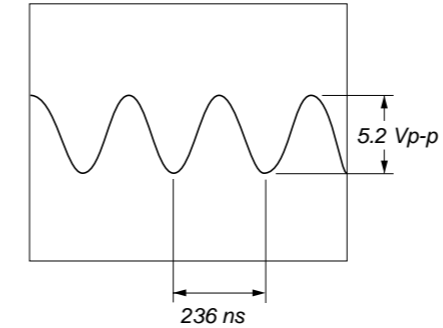

23 IC801 02 (TX)

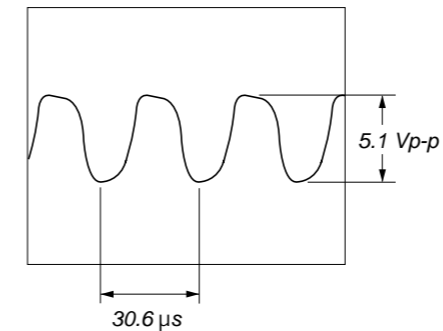

6-5. PRINTED WIRING BOARD – CD Section – • See page 18 for Circuit Boards Location.

• Semiconductor Location

Ref. No.	Location
IC101	C-3
IC102	B-3
IC103	C-2
Q101	B-2

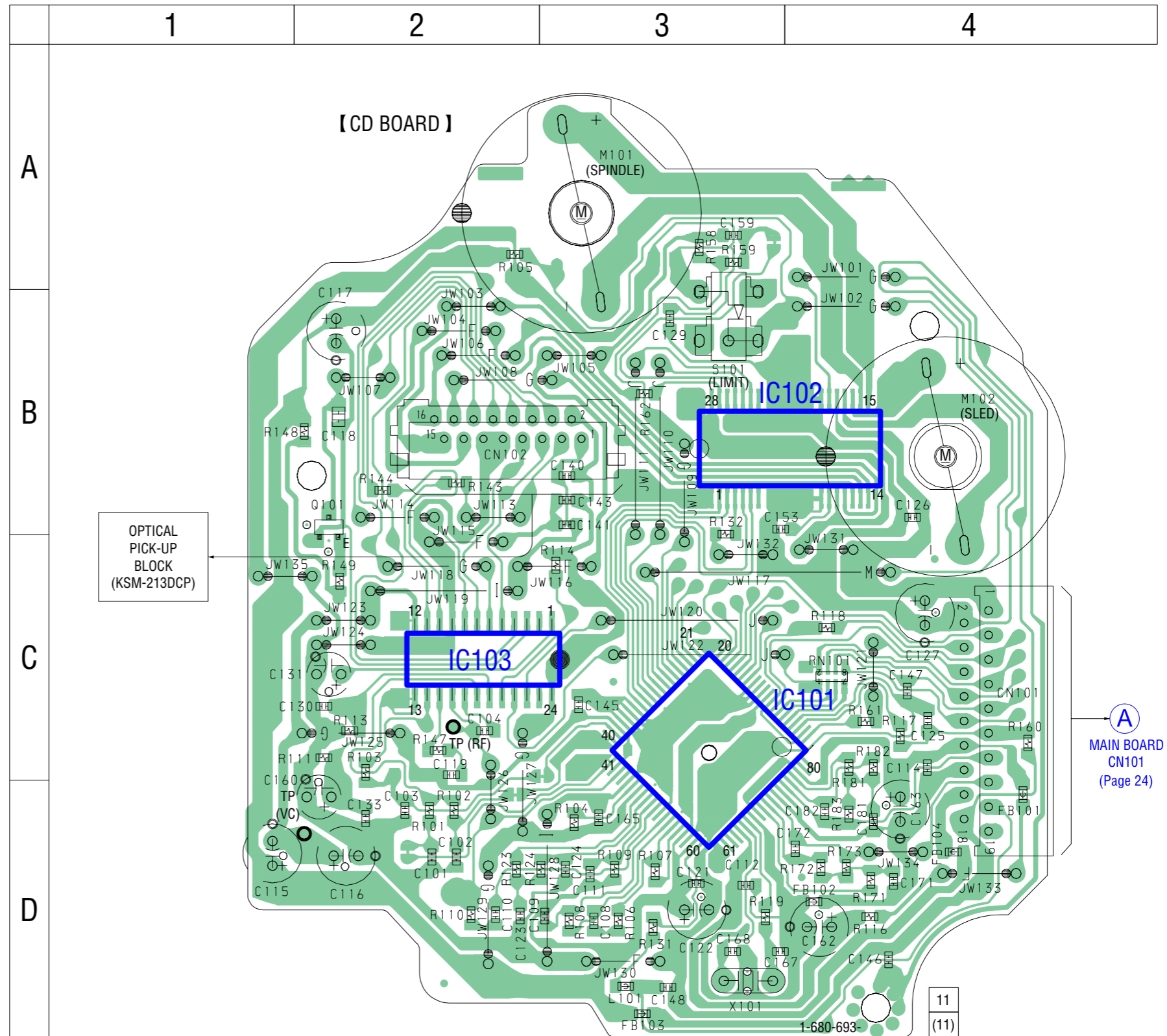

6-6. SCHEMATIC DIAGRAM – CD Section – • See page 19 for Waveforms. • See page 32 for IC Block Diagrams.

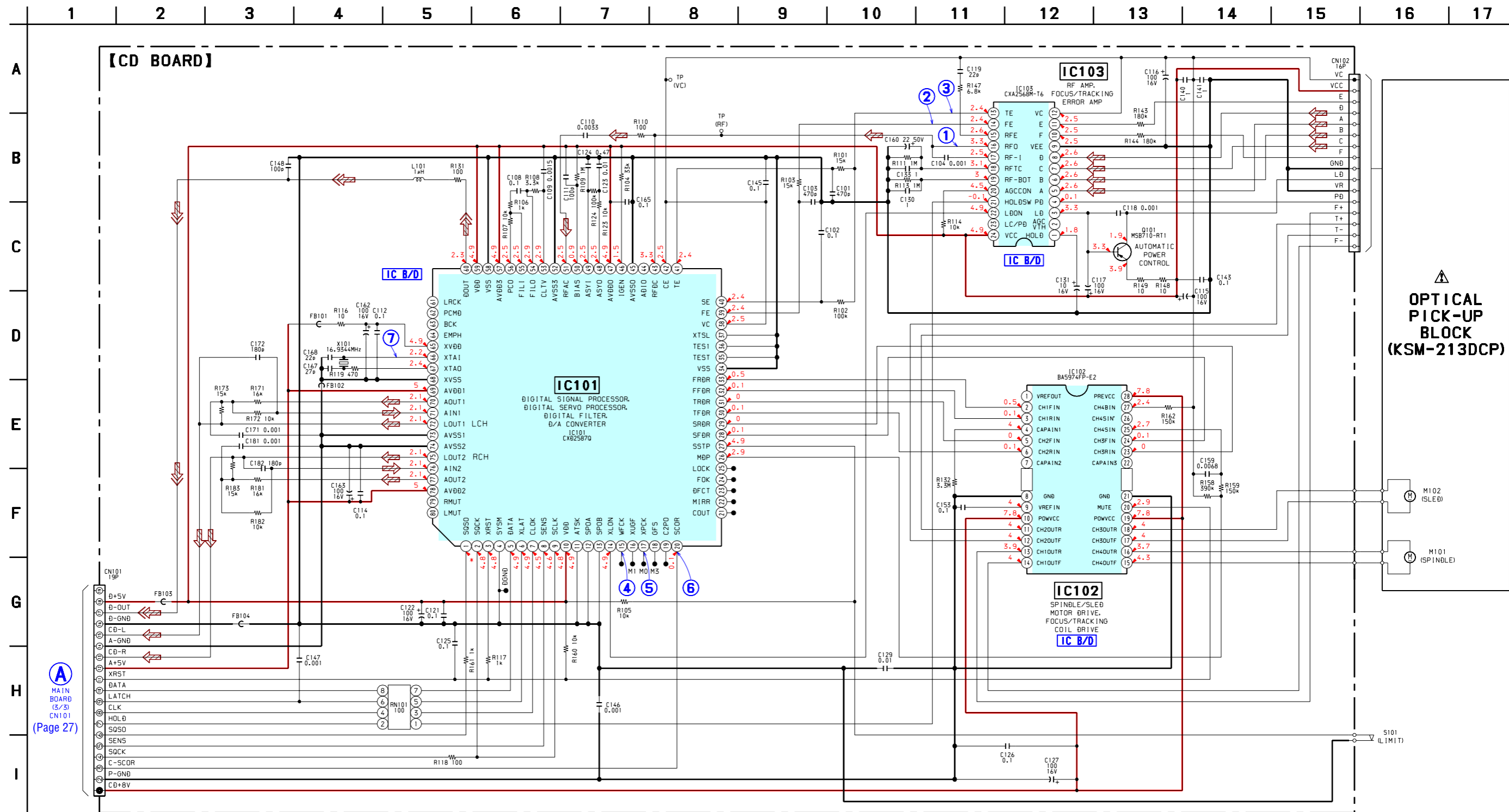

A
MAIN BOARD (3/3)
CN101
(Page 27)

- Voltages and waveforms are dc with respect to ground under no-signal conditions.
- no mark : CD PLAY
- * : Impossible to measure

The components identified by mark Δ or dotted line with mark Δ are critical for safety. Replace only with part number specified.

Les composants identifiés par une marque Δ sont critiques pour la sécurité. Ne les remplacer que par une pièce portant le numéro spécifié.

6-7. PRINTED WIRING BOARD – TAPE DECK Section – • See page 18 for Circuit Boards Location.

• Semiconductor Location

Ref. No.	Location
D401	B-4
IC401	C-4
Q100	D-2
Q101	D-3
Q200	D-4
Q201	D-4
Q401	D-2
Q402	D-2
Q403	B-3
Q404	C-3
Q405	C-3

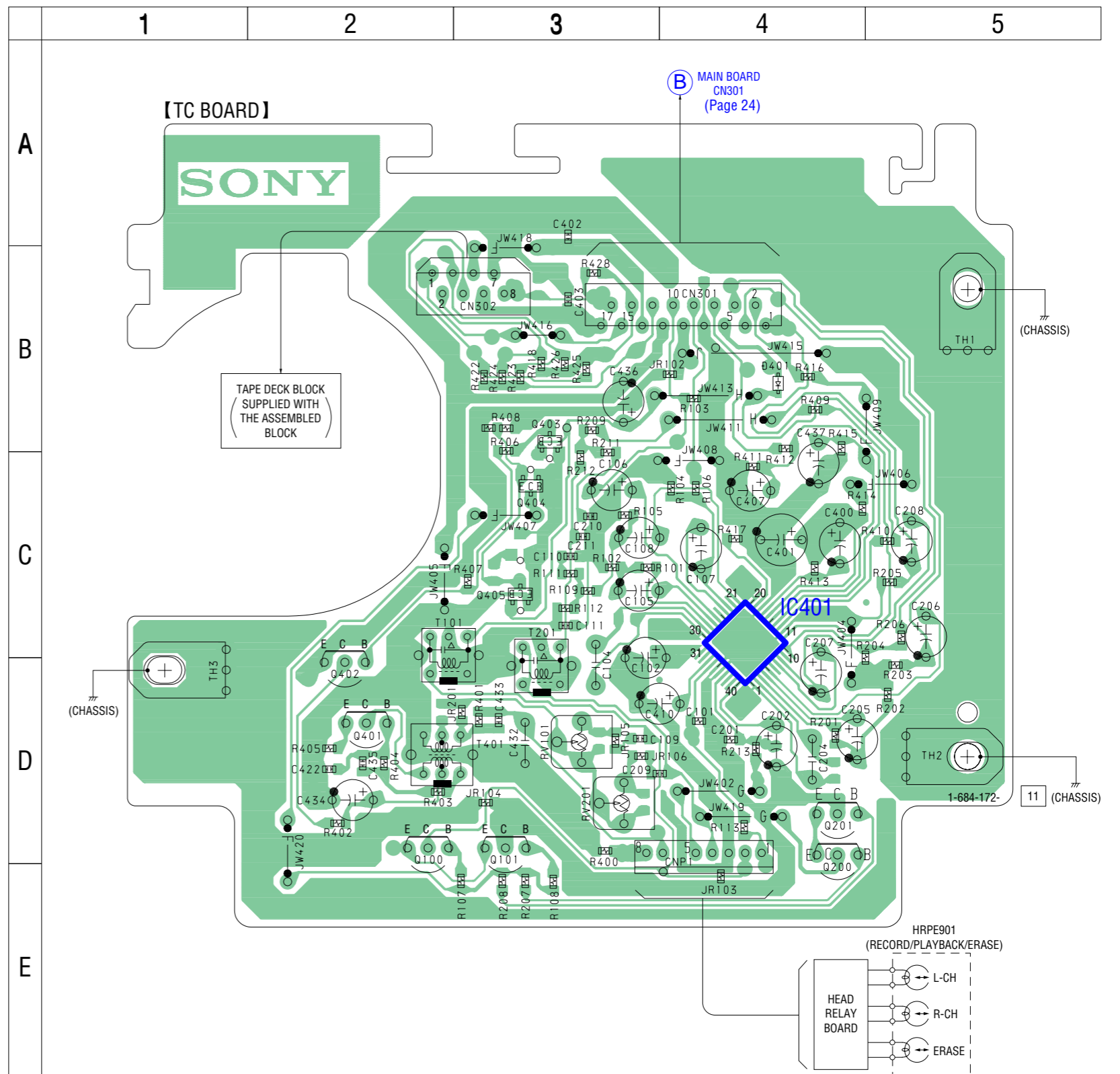

6-8. SCHEMATIC DIAGRAM – TAPE DECK Section – • See page 19 for Waveforms. • See page 32 for IC Block Diagram.

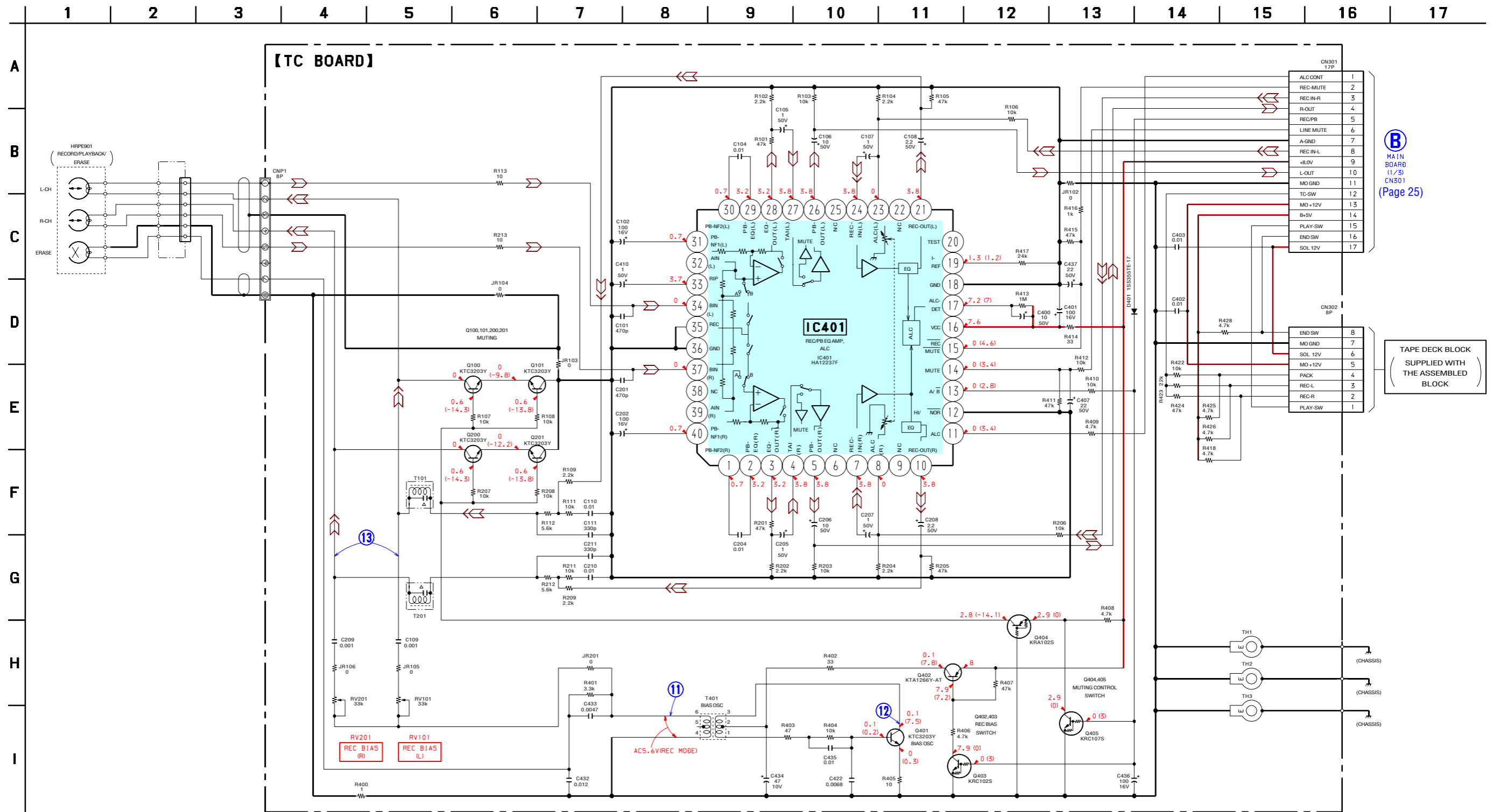

(B)
MAIN BOARD (1/3) CN301 (Page 25)

TAPE DECK BLOCK (SUPPLIED WITH THE ASSEMBLED BLOCK)

• Voltages and waveforms are dc with respect to ground under no-signal conditions.
no mark : TAPE PLAY
() : TAPE REC

6-9. PRINTED WIRING BOARDS – MAIN Section – • See page 18 for Circuit Boards Location.

• Semiconductor Location

Ref. No.	Location	Ref. No.	Location
D301	C-12	Q303	C-11
D303	H-8	Q304	C-11
D304	G-7	Q305	J-10
D305	C-12	Q306	J-8
D307	J-10	Q307	J-9
D308	J-8	Q308	I-8
D309	G-10	Q310	D-10
D310	H-9	Q312	E-10
D311	I-11	Q313	D-10
D601	J-7	Q330	G-9
D602	J-7	Q355	J-11
D801	D-8	Q501	F-10
D802	E-7	Q502	F-10
D805	B-11	Q601	J-7
D806	D-10	Q602	J-7
D807	H-8	Q603	J-7
D808	E-10	Q604	I-7
D811	E-10	Q605	I-7
D812	H-8	Q606	I-7
D866	B-1	Q607	I-8
D867	B-1	Q608	I-8
D868	B-5	Q609	I-7
D869	B-5	Q802	F-7
		Q803	F-7
IC101	I-12	Q804	F-8
IC201	G-12	Q805	F-7
IC301	H-8	Q806	F-7
IC304	J-10	Q807	F-7
IC306	I-9	Q808	F-7
IC320	H-7	Q810	B-10
IC321	C-12	Q811	B-10
IC323	G-10	Q812	B-11
IC324	E-11	Q813	B-10
IC801	C-7	Q814	C-10
IC803	B-9	Q815	D-11
IC804	C-11	Q816	D-11
		Q817	D-11
Q100	G-9	Q818	D-11
Q200	G-9	Q890	E-9
Q301	B-11	Q891	E-9

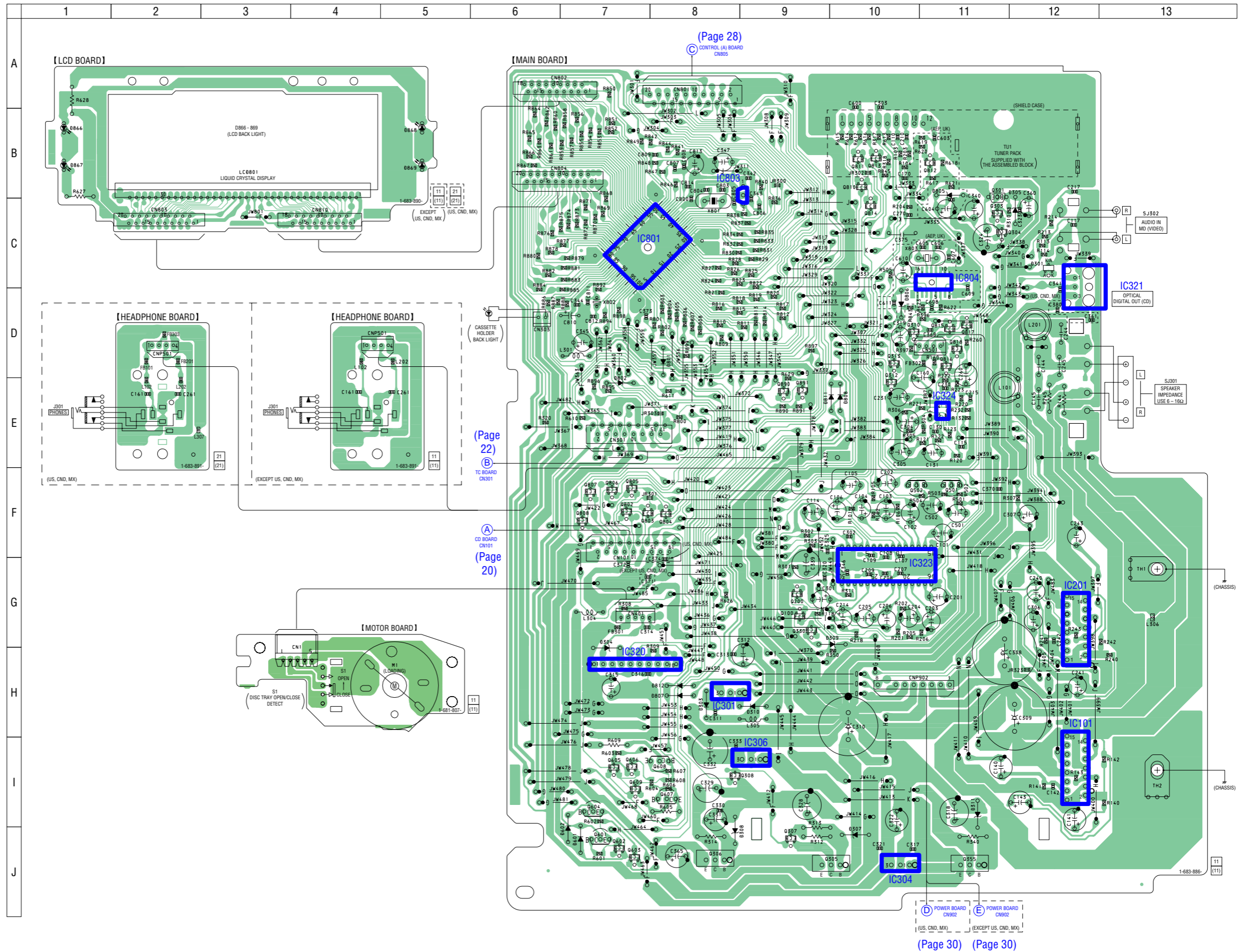

6-11. SCHEMATIC DIAGRAM – MAIN Section (2/3) – • See page 32 for IC Block Diagrams.

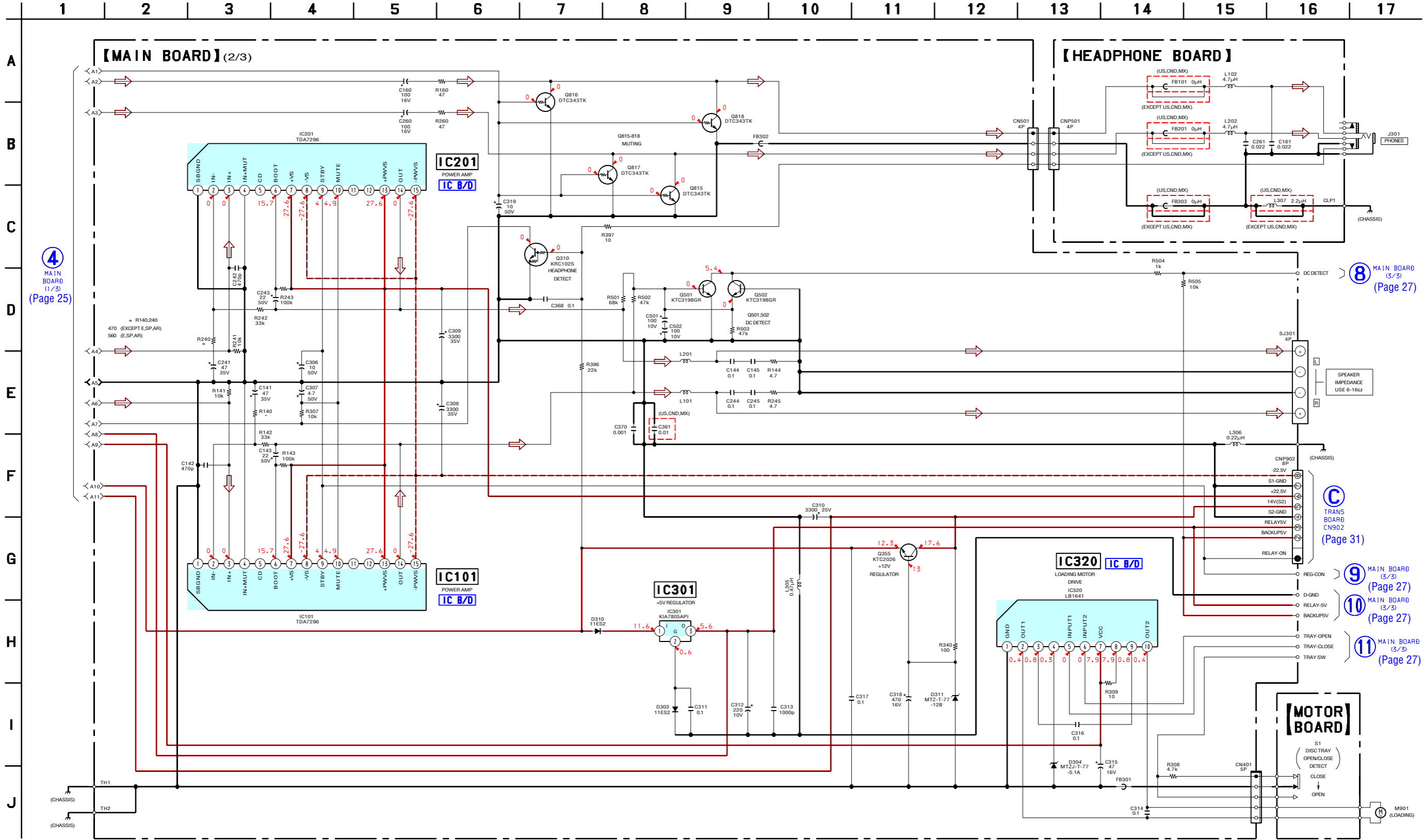

4 MAIN BOARD (1/3) (Page 25)

8 MAIN BOARD (3/3) (Page 27)

C TRANS BOARD CN902 (Page 31)

9 MAIN BOARD (3/3) (Page 27)

10 MAIN BOARD (3/3) (Page 27)

11 MAIN BOARD (3/3) (Page 27)

• Voltages and waveforms are dc with respect to ground under no-signal (detuned) conditions.
no mark : TUNER
() : CD PLAY
<< >> : TAPE PLAY

6-12. SCHEMATIC DIAGRAM – MAIN Section (3/3) – • See page 19 for Waveforms. • See page 32 for IC Block Diagram.

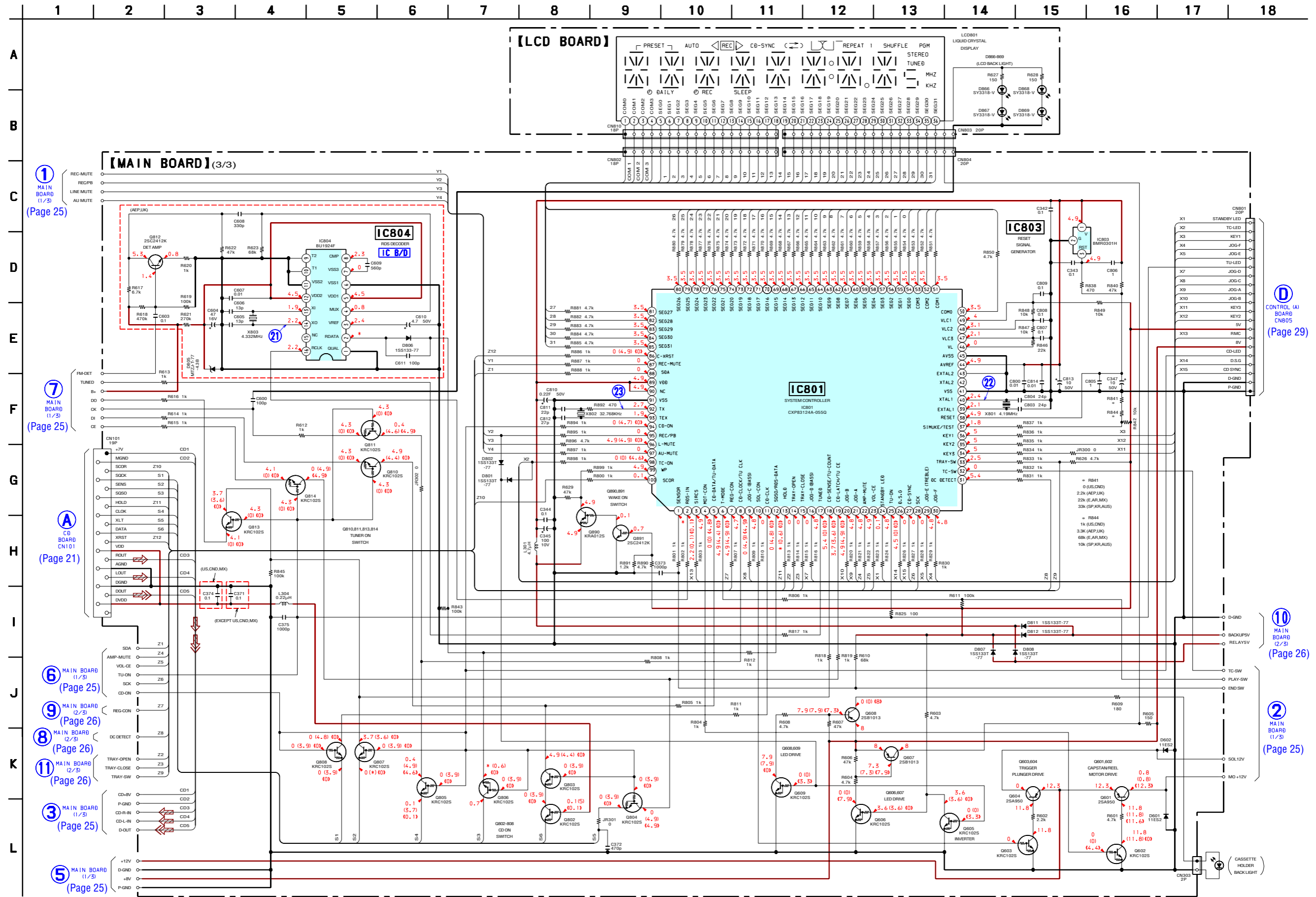

• Voltages and waveforms are dc with respect to ground under no-signal (detuned) conditions.
 no mark : TUNER
 () : CD PLAY
 << >> : TAPE PLAY
 * : Impossible to measure

6-13. PRINTED WIRING BOARDS – CONTROL Section – • See page 18 for Circuit Boards Location.

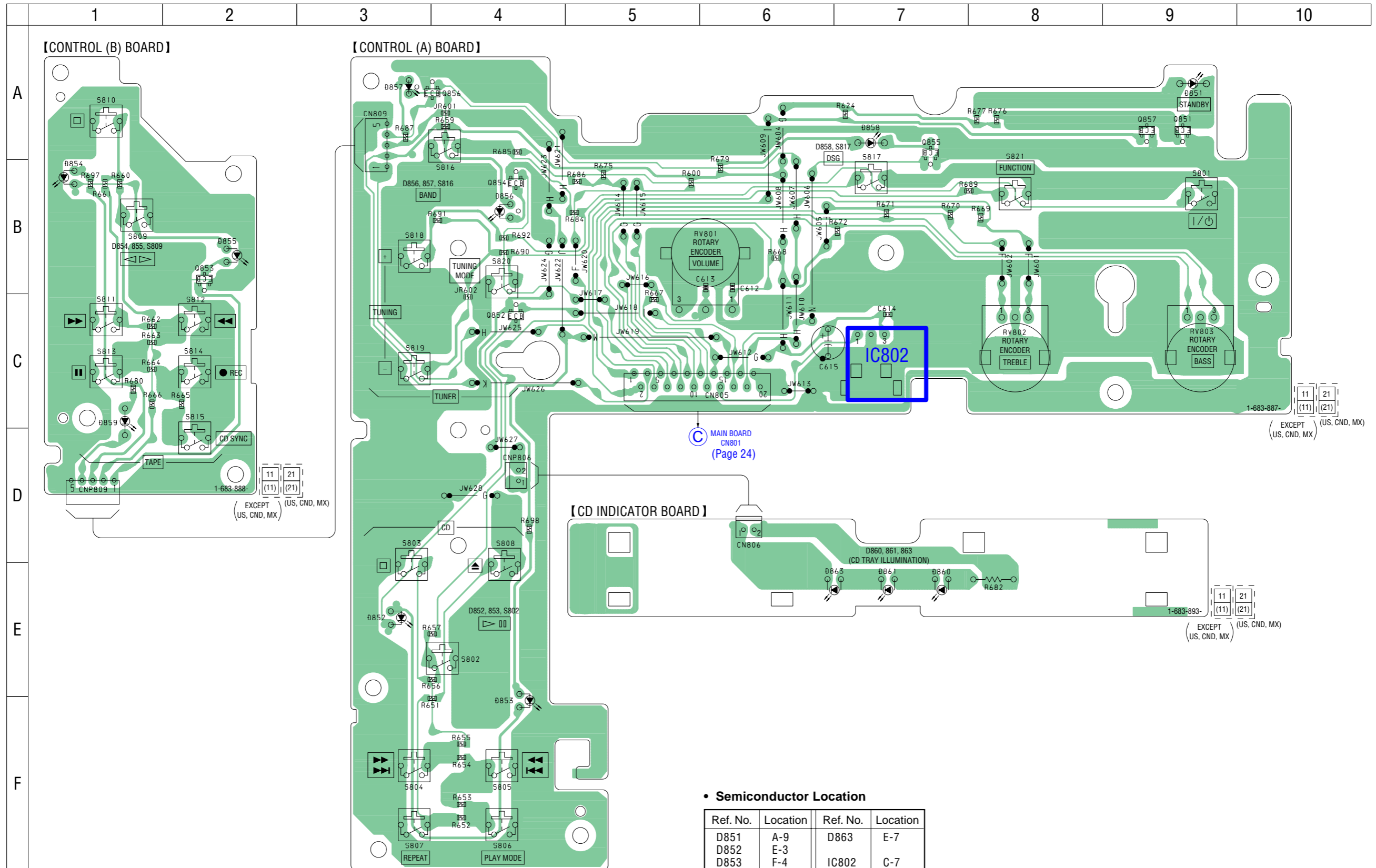

• Semiconductor Location

Ref. No.	Location	Ref. No.	Location
D851	A-9	D863	E-7
D852	E-3	IC802	C-7
D853	F-4	Q851	A-9
D854	B-1	Q852	C-4
D855	B-2	Q853	B-2
D856	B-4	Q854	B-4
D857	A-4	Q855	A-7
D858	A-7	Q856	A-4
D859	C-1	Q857	A-9
D860	E-7		
D861	E-7		

6-14. SCHEMATIC DIAGRAM – CONTROL Section –

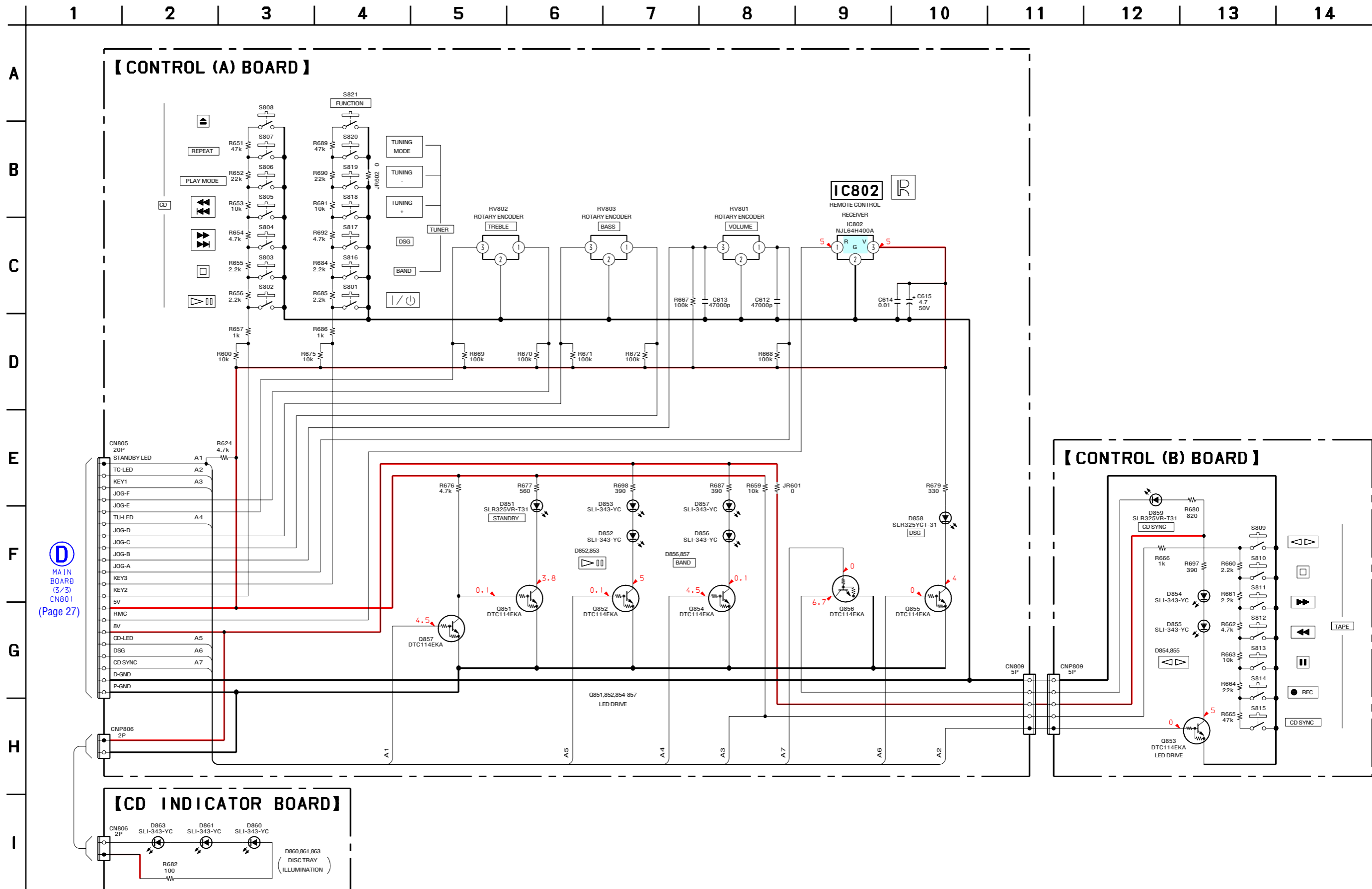

• Voltages and waveforms are dc with respect to ground under no-signal (detuned) conditions.
 no mark : TUNER

6-15. PRINTED WIRING BOARD – POWER Section (US, Canadian, Mexican models) –

• See page 18 for Circuit Boards Location.

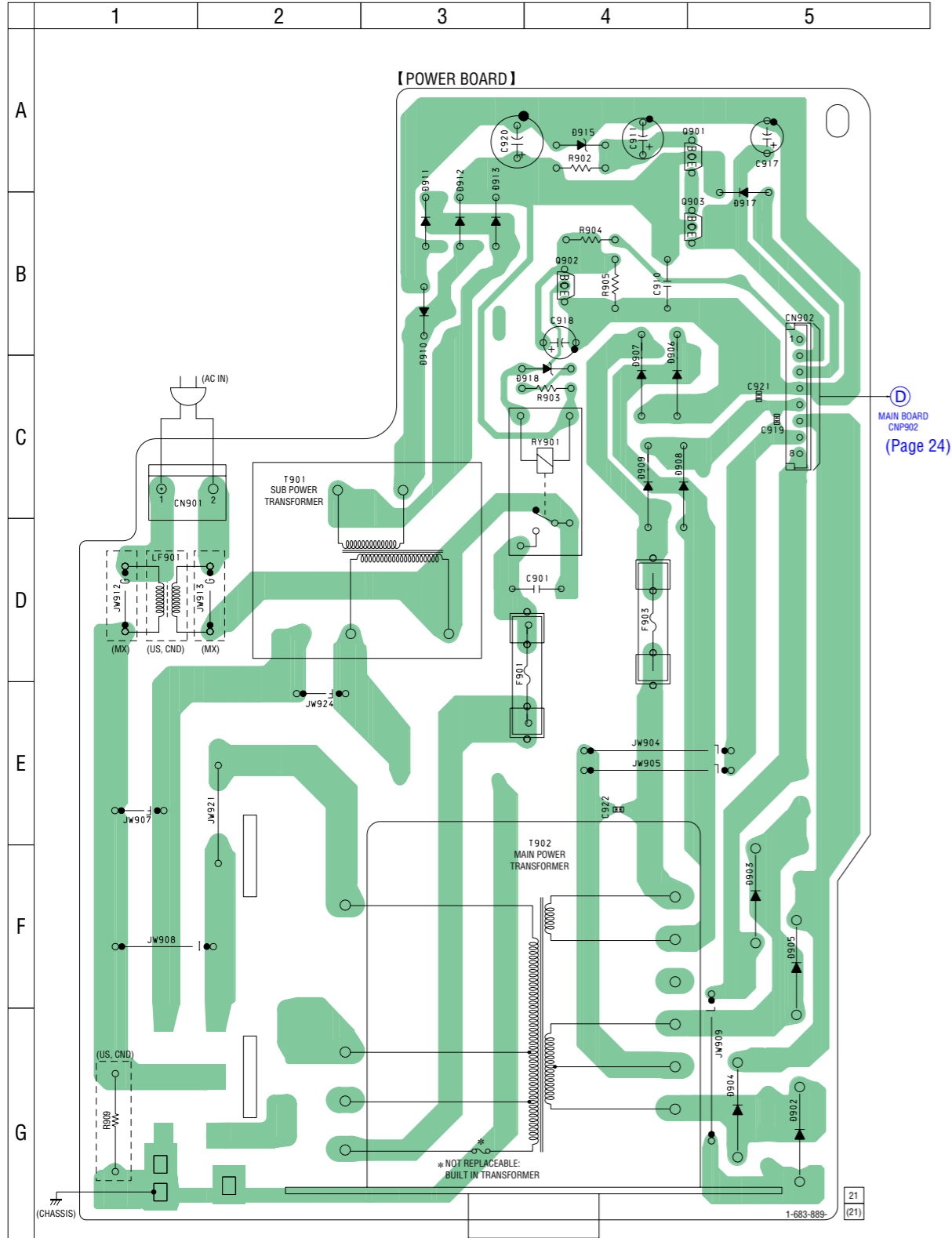

• Semiconductor Location

Ref. No.	Location	Ref. No.	Location
D902	G-5	D912	B-3
D903	F-5	D913	B-3
D904	G-5	D915	A-4
D905	F-5	D917	B-5
D906	C-4	D918	C-4
D907	C-4		
D908	C-4	Q901	A-5
D909	C-4	Q902	B-4
D910	B-3	Q903	B-5
D911	B-3		

6-16. PRINTED WIRING BOARD – POWER Section (Except US, Canadian, Mexican models) –

• See page 18 for Circuit Boards Location.

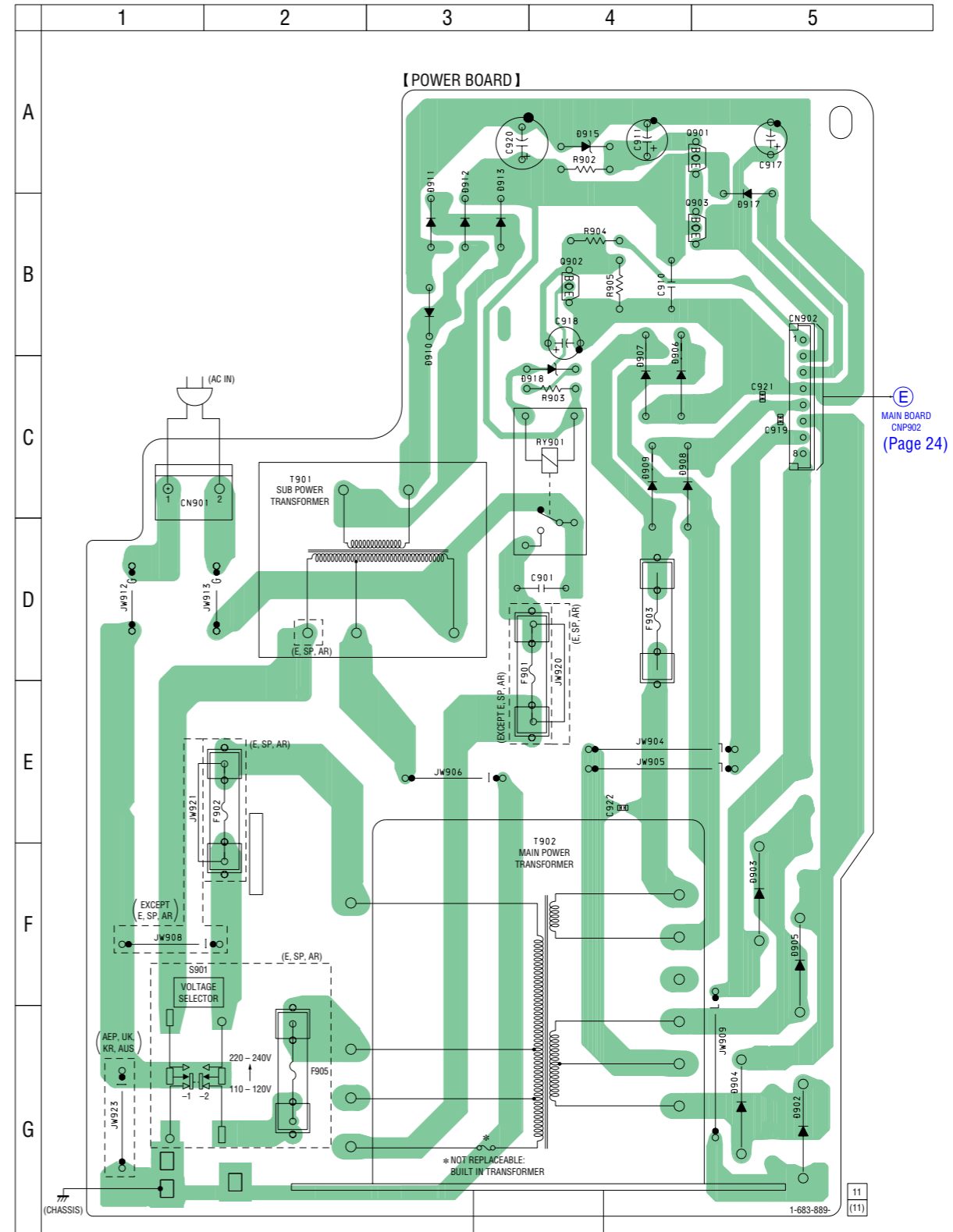

• Semiconductor Location

Ref. No.	Location	Ref. No.	Location
D902	G-5	D912	B-3
D903	F-5	D913	B-3
D904	G-5	D915	A-4
D905	F-5	D917	B-5
D906	C-4	D918	C-4
D907	C-4		
D908	C-4	Q901	A-5
D909	C-4	Q902	B-4
D910	B-3	Q903	B-5
D911	B-3		

6-17. SCHEMATIC DIAGRAM – POWER Section –

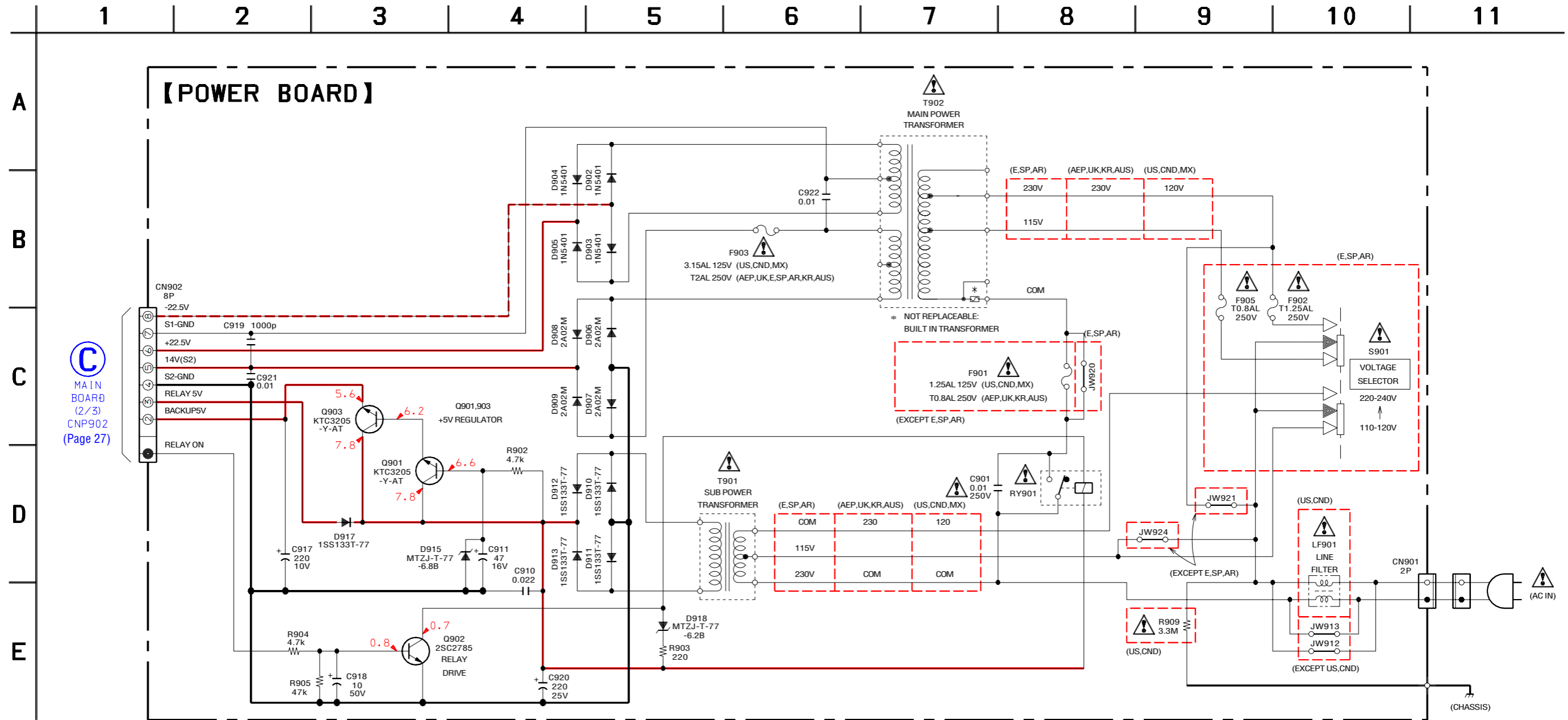

C
MAIN BOARD
(2/3)
CNP902
(Page 27)

• Voltages and waveforms are dc with respect to ground under no-signal (detuned) conditions.
no mark : TUNER

The components identified by mark \triangle or dotted line with mark \triangle are critical for safety. Replace only with part number specified.	Les composants identifiés par une marque \triangle sont critiques pour la sécurité. Ne les remplacer que par une pièce portant le numéro spécifié.
--	--

HCD-CP101

• IC Block Diagrams
– CD Board –

IC101 CXD2587Q

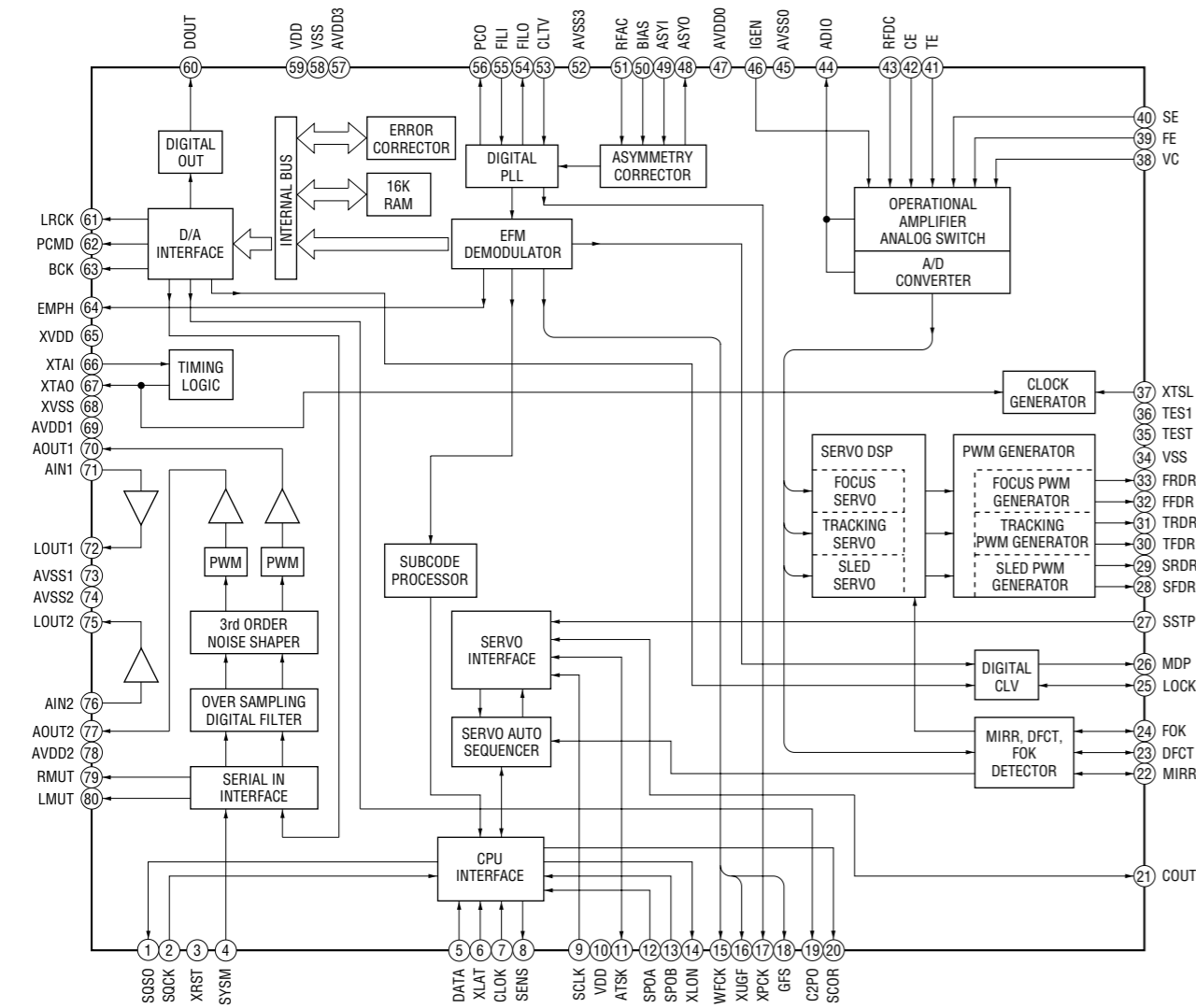

IC102 BA5974FP-E2

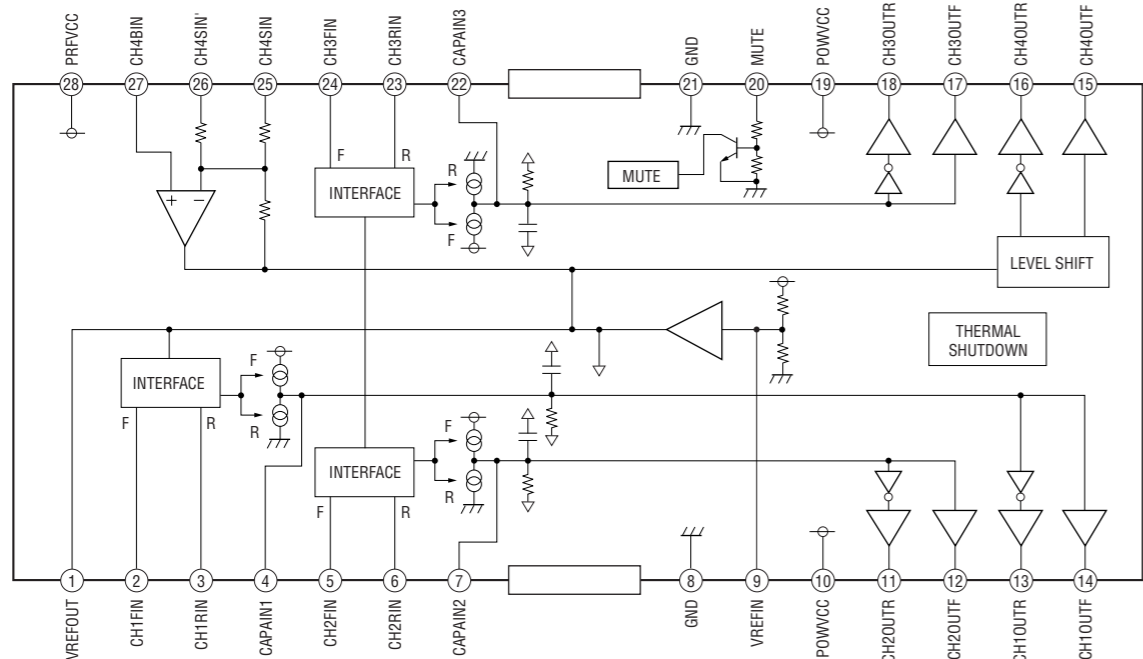

IC103 CXA2568M-T6

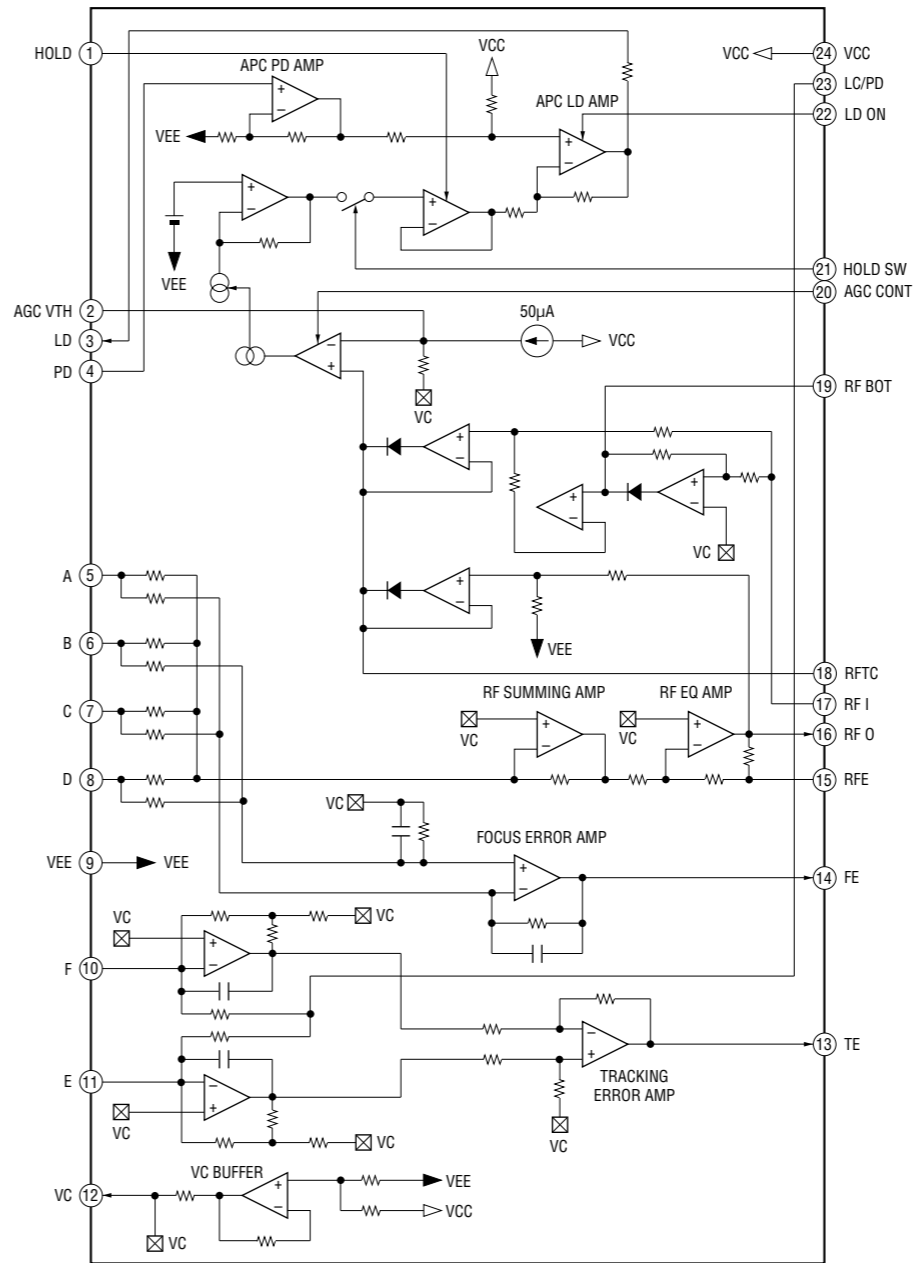

– MAIN Board –

IC101, 201 TDA7296

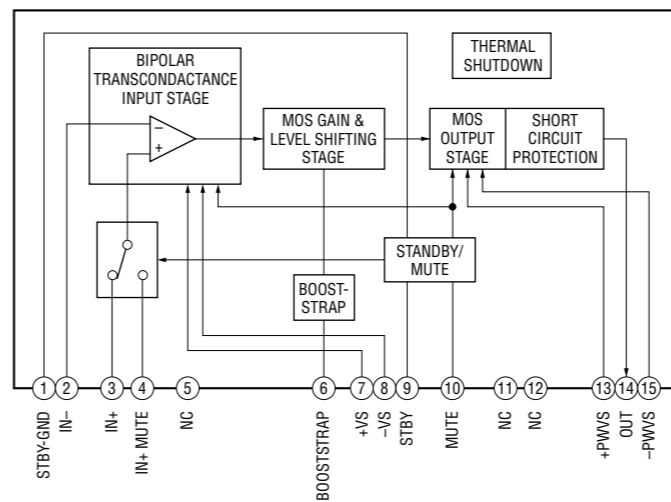

IC320 LB1641

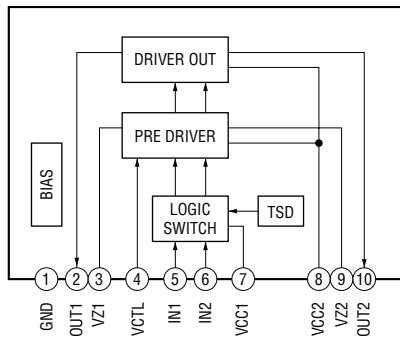

IC323 LC75342

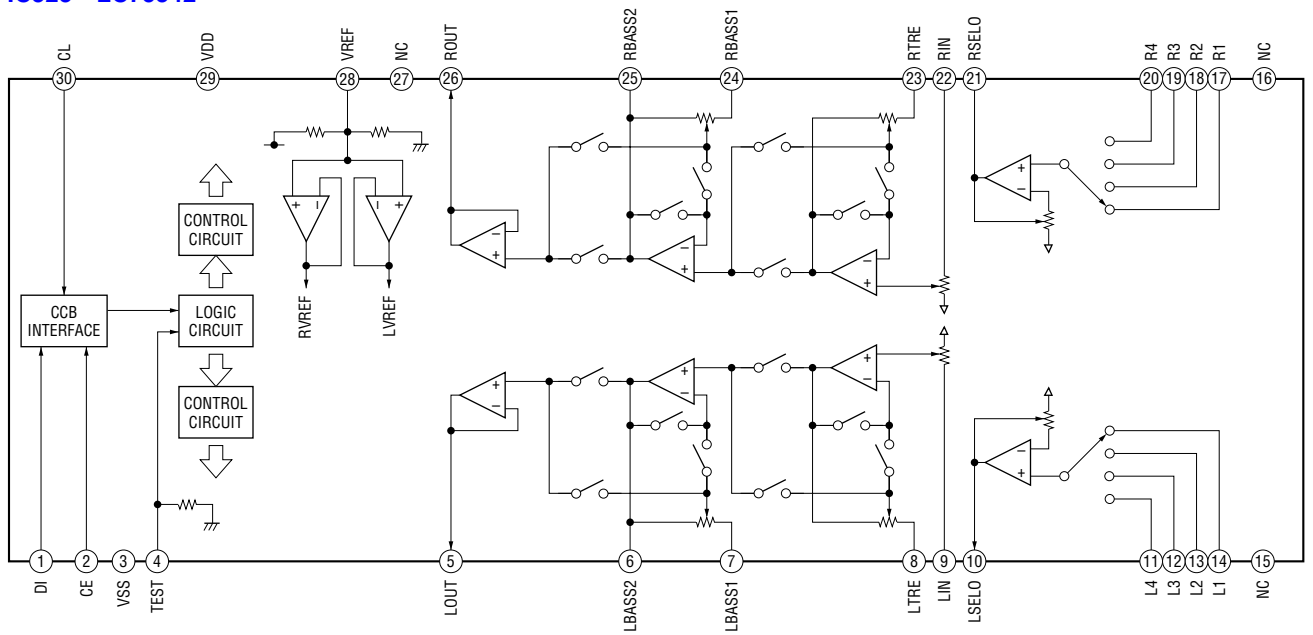

IC804 BU1924F-E2

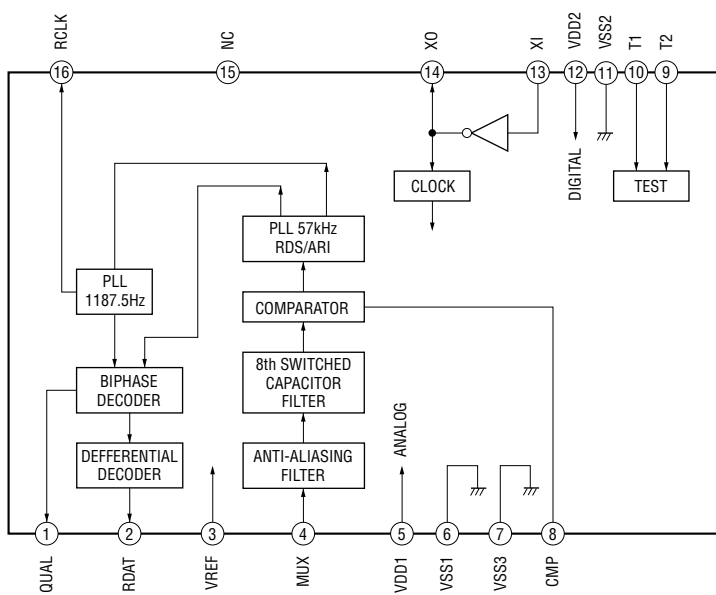

6-18. IC PIN FUNCTION DESCRIPTION

• MAIN BOARD IC801 CXP83124A-055Q (SYSTEM CONTROLLER)

Pin No.	Pin Name	I/O	Description
1	SENSOR	I	Tape end detect sensor input terminal "H": input when the tape end detected
2	RDS-IN	I	Serial data reading clock signal input from the RDS decoder Used for the AEP, UK models (Except AEP, UK models: not used)
3	SIRCS	I	Remote control signal input from the remote control receiver
4	MOT-CON	O	Capstan/reel motor on/off control signal output terminal "H": motor on
5	CD-DATA/ TU-DATA	O	Serial data output to the CXD2587Q (at CD function) PLL serial data output to the tuner pack (at tuner function)
6	T-MODE	I	Head position detect switch input terminal "L": forward direction, "H": reverse direction
7	REG-CON	O	Main system power supply on/off control signal output terminal "H": power on
8	CD-CLK/TU- CLK	O	Serial data transfer clock signal output to the CXD2587Q (at CD function) PLL serial data transfer clock signal output to the tuner pack (at tuner function)
9	JOG-C (BASS)	I	Jog dial pulse input from the rotary encoder (BASS) (C phase input)
10	SOL-CON	O	Trigger plunger on/off control signal output terminal "H": plunger on
11	CD-CLK	O	Subcode Q data reading clock signal output to the CXD2587Q (at CD function)
12	SQSO/ RDS-DATA	I	Subcode Q data input from the CXD2587Q (at CD function) RDS serial data input from the RDS decoder (at tuner function) Used for the AEP, UK models (Except AEP, UK models: not used)
13	HOLD	O	Automatic power control hold signal output to the RF amplifier
14	TRAY-OPEN	O	Motor drive signal output to the loading motor drive "H": active *1
15	TRAY-CLOSE	O	Motor drive signal output to the loading motor drive "H": active *1
16	JOG-D (BASS)	I	Jog dial pulse input from the rotary encoder (BASS) (D phase input)
17	TUNED	I	Tuning detection signal input from the tuner pack (at tuner function)
18	CD-SENSE/ TU COUNT	I	Internal status (SENSE) input from the CXD2587Q (at CD function) PLL count data input from the tuner pack (at tuner function)
19	CD-LATCH/ TU CE	O	Serial data latch pulse output to the CXD2587Q (at CD function) PLL serial chip enable signal output to the tuner pack (at tuner function)
20	JOG-B	I	Jog dial pulse input from the rotary encoder (VOLUME) (B phase input)
21	JOG-A	I	Jog dial pulse input from the rotary encoder (VOLUME) (A phase input)
22	AMP-MUTE	O	Muting on/off control signal output to the power amplifier "H": muting on
23	VOL-CE	O	Chip enable signal output for the electrical volume
24	STANDBY LED	I	LED drive signal output of the STANDBY indicator (D856) "H": LED on
25	TU-ON	O	Power supply on/off control signal output of the tuner section LED drive signal output of the BAND indicator "H": tuner power on (LED on)
26	D. S. G.	O	LED drive signal output of the DSG (Dynamic Sound Generator) indicator "H": LED on
27	CD-SYNC	O	LED drive signal output of the CD SYNC indicator "H": LED on
28	SCK	O	Serial data transfer clock signal output to the electrical volume
29	JOG-E (TREBLE)	I	Jog dial pulse input from the rotary encoder (TREBLE) (E phase input)
30	JOG-F	I	Jog dial pulse input from the rotary encoder (TREBLE) (F phase input)
31	DC DETECT	I	Speaker DC output protect signal input terminal

*1 Loading motor control

Terminal	Mode			
	Stop	Table In	Table Out	Brake
TRAY-OPEN (pin ⑭)	"L"	"L"	"H"	"H"
TRAY-CLOSE (pin ⑮)	"L"	"H"	"L"	"H"

Pin No.	Pin Name	I/O	Description
32	TC-SW	I	Half detect (side A and B) switch and cassette in detect switch input terminal (A/D input)
33	TRAY-SW	I	Disc tray open/close detect switch input terminal (A/D input) "L": open position
34	KEY3	I	Key input terminal (A/D input)
35	KEY2	I	Key input terminal (A/D input)
36	KEY1	I	Key input terminal (A/D input)
37	SIMUKE/TEST	I	Destination setting terminal (A/D input)
38	<u>RESET</u>	I	System reset signal input from the reset signal generator "L": reset For several hundreds msec. after the power supply rises, "L": is input, then it changes to "H"
39	EXTAL1	I	Main system clock input terminal (4.19MHz)
40	XTAL1	O	Main system clock output terminal (4.19MHz)
41	VSS	—	Ground terminal
42	XTAL2	O	Sub system clock output terminal Not used
43	EXTAL2	I	Sub system clock input terminal Not used
44	AVREF	I	Reference voltage (+5V) input terminal (for A/D conversion)
45	AVSS	—	Ground terminal (for A/D conversion)
46	VL	O	Not used
47 to 49	VLC3 to VLC1	—	Power supply terminal for the liquid crystal display bias
50 to 53	COM0 to COM3	O	Common drive signal output to the liquid crystal display
54 to 85	SEG0 to SEG31	O	Segment drive signal output to the liquid crystal display
86	C-XRST	O	Reset signal output to the CXD2587Q and BA5974FP (at CD function)
87	REC-MUTE	O	Recording muting on/off selection signal output to the tape deck section "H": muting on, "L": muting of
88	SDA	O	Serial data output to the electrical volume
89	VDD	—	Power supply terminal (+5V)
90	NC	—	Not used (open)
91	VSS	—	Ground terminal
92	TX	O	Sub system clock output terminal (32.768kHz)
93	TEX	I	Sub system clock input terminal (32.768kHz)
94	CD-ON	O	Power supply on/off control signal output of the CD section LED drive signal output of the CD ► indicator "H": CD power on (LED on)
95	REC/PB	O	Recording/playback selection signal output to the tape deck section "L": playback mode, "H": recording mode
96	L-MUTE	O	Line muting on/off selection signal output to the tape deck section "H": muting on, "L": muting off
97	AU MUTE	O	muting on/off control signal output terminal "H": muting on
98	TC-ON	O	Power supply on/off control signal output of the cassette holder back light LED drive signal output of the TAPE ◀▶ indicator "H": back light on (LED on)
99	WP	I	Wakeup control signal input terminal
100	SCOR	I	Subcode sync (S0+S1) detection signal input from the CXD2587Q (at CD function)

SECTION 7 EXPLODED VIEWS

NOTE:

- XX and -X mean standardized parts, so they may have some difference from the original one.

• Color Indication of Appearance Parts

Example:

KNOB, BALANCE (WHITE) . . . (RED)

↑ ↑
Parts Color Cabinet's Color

• Abbreviation

- | | |
|------------------------|----------------------|
| AR : Argentina model | KR : Korean model |
| AUS : Australian model | MX : Mexican model |
| CND : Canadian model | SP : Singapore model |

- Items marked “*” are not stocked since they are seldom required for routine service. Some delay should be anticipated when ordering these items.
- Accessories are given in the last of the electrical parts list.

The components identified by mark \triangle or dotted line with mark \triangle are critical for safety. Replace only with part number specified.

Les composants identifiés par une marque \triangle sont critiques pour la sécurité. Ne les remplacer que par une pièce portant le numéro spécifié.

7-1. COVER SECTION

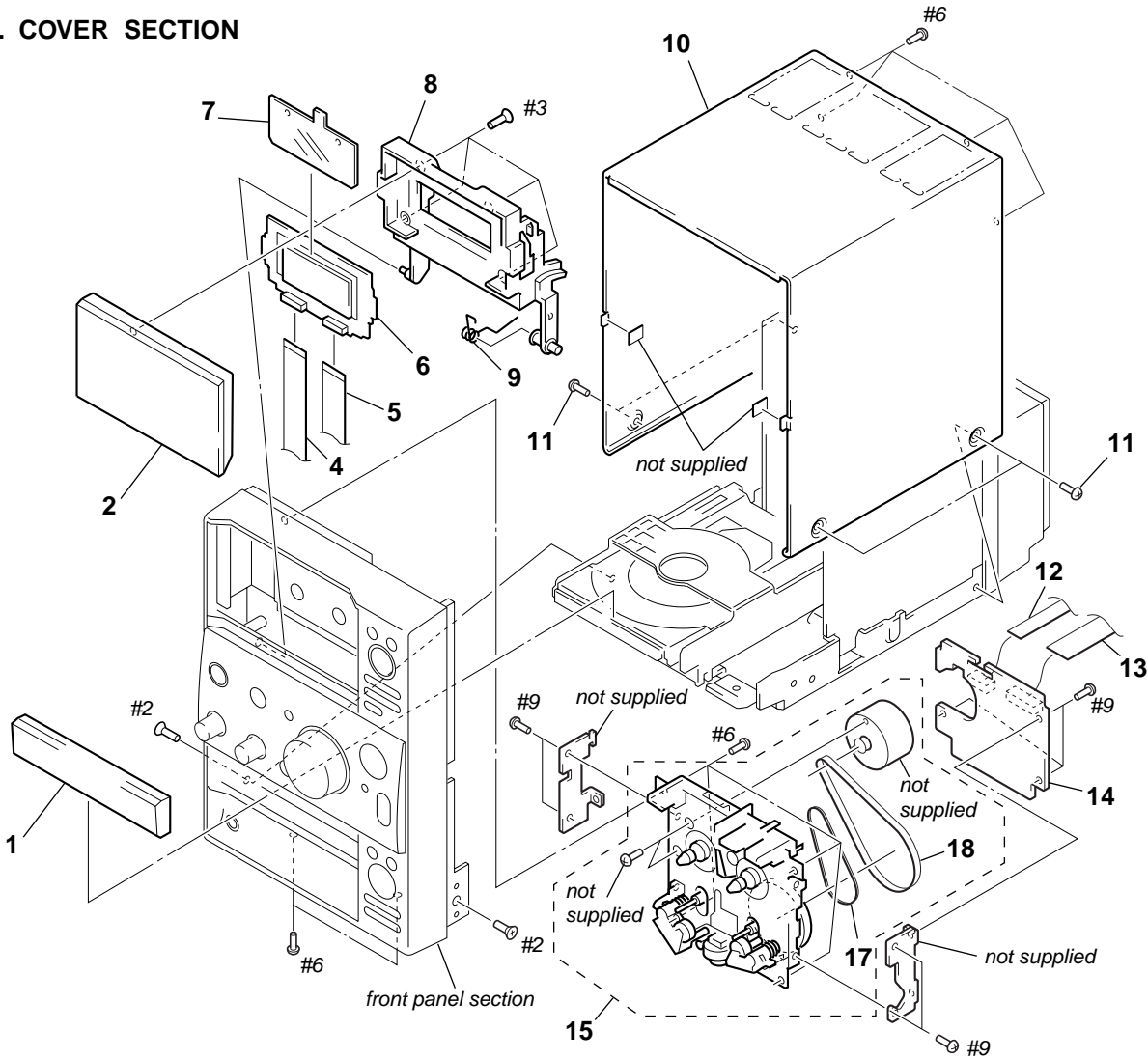

Ref. No.	Part No.	Description	Remark	Ref. No.	Part No.	Description	Remark
1	X-4954-469-1	LID SUB ASSY, CD		11	4-221-580-01	SCREW, CASE	
2	X-4954-468-1	LID SUB ASSY, CASSETTE		12	1-824-335-11	WIRE (FLAT TYPE) (EEC) (8 CORE)	
4	1-757-808-11	CABLE, FLEXIBLE FLAT (18 CORE)		13	1-773-044-11	WIRE (FLAT TYPE) (17 CORE)	
5	1-757-807-11	CABLE, FLEXIBLE FLAT (20 CORE)		14	A-4728-263-A	TC BOARD, COMPLETE	
6	1-683-890-11	LCD BOARD (AEP, UK, E, AR, SP, KR, AUS)		15	1-796-353-11	DECK, MECHANICAL	
6	1-683-890-21	LCD BOARD (US, CND, MX)		17	4-241-659-01	BELT	
7	4-217-319-11	PLATE, LCD LIGHT		18	4-241-718-01	BELT (FLAT)	
8	X-4954-467-1	CASSETTE HOLDER SUB ASSY		#2	7-685-245-19	SCREW +KTP 3X6 TYPE2 NON-SLIT	
9	4-238-310-01	SPRING, OPEN		#3	7-685-246-14	SCREW +KTP 3X8 TYPE2 NON-SLIT	
10	4-217-341-61	COVER (UPPER) (US, CND, AEP, E, KR, MX, AR, SP, AUS)		#6	7-685-546-14	SCREW +BTP 3X8 TYPE2 N-S	
10	4-238-306-01	COVER, UPPER (UK)		#9	7-685-861-01	SCREW +BVTT 2.6X5 (S)	

7-2. FRONT PANEL SECTION

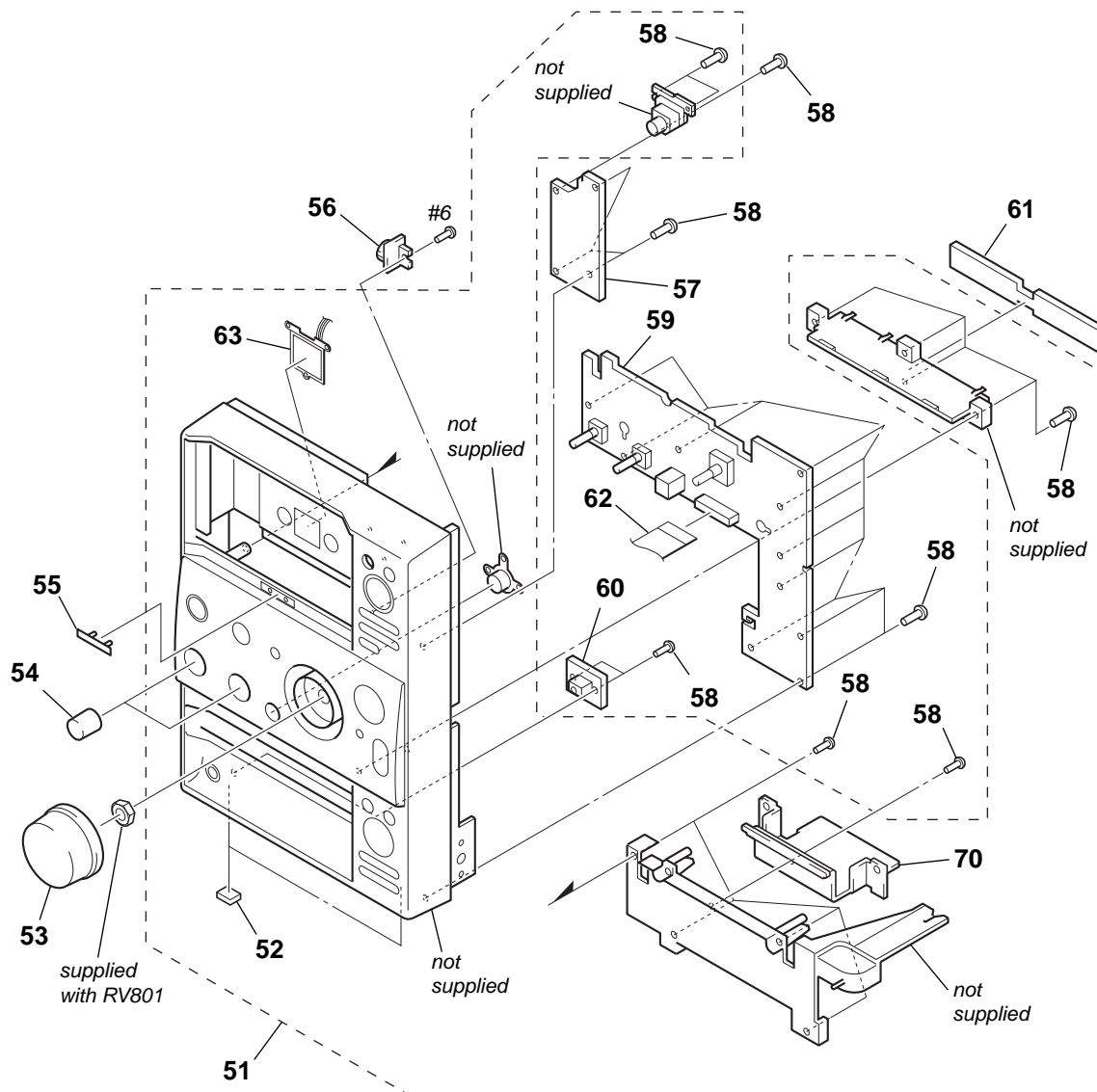

Ref. No.	Part No.	Description	Remark	Ref. No.	Part No.	Description	Remark
51	X-4954-463-1	FRONT PANEL SUB ASSY (AEP, UK, E, KR, MX, AR, SP, AUS)		59	A-4728-258-A	CONTROL (A) BOARD, COMPLETE (AEP, UK, E, AR, SP, AUS)	
51	X-4954-867-1	FRONT PANEL SUB ASSY (US, CND)		59	A-4729-391-A	CONTROL (A) BOARD, COMPLETE (US, CND, MX)	
51	X-4954-963-1	FRONT PANEL SUB ASSY (KR)		59	A-4730-021-A	CONTROL (A) BOARD, COMPLETE (KR)	
52	4-232-478-01	FOOT		60	1-683-891-11	HEADPHONE BOARD (AEP, UK, E, AR, SP, KR, AUS)	
53	4-238-307-01	KNOB (VOL)		60	1-683-891-21	HEADPHONE BOARD (US, CND, MX)	
54	4-238-308-01	KNOB (BASS)		61	1-683-893-11	CD INDICATOR BOARD (AEP, UK, E, AR, SP, KR, AUS)	
55	4-238-570-01	COVER, AZIMUTH		61	1-683-893-21	CD INDICATOR BOARD (US, CND, MX)	
56	3-351-377-11	GEAR, DAMPER		62	1-757-807-11	CABLE, FLEXIBLE FLAT (20 CORE)	
57	A-4728-262-A	CONTROL (B) BOARD, COMPLETE (AEP, UK, E, AR, SP, AUS)		63	1-477-315-11	INDICATOR BLOCK, LED	
57	A-4729-394-A	CONTROL (B) BOARD, COMPLETE (US, CND, MX)		70	4-238-309-01	BRACKET (MD)	
57	A-4730-024-A	CONTROL (B) BOARD, COMPLETE (KR)		#6	7-685-546-14	SCREW +BTP 3X8 TYPE2 N-S	
58	4-931-757-31	SCREW (DIA.2.6X8) (IT3B), TAPPING					

7-3. CHASSIS SECTION

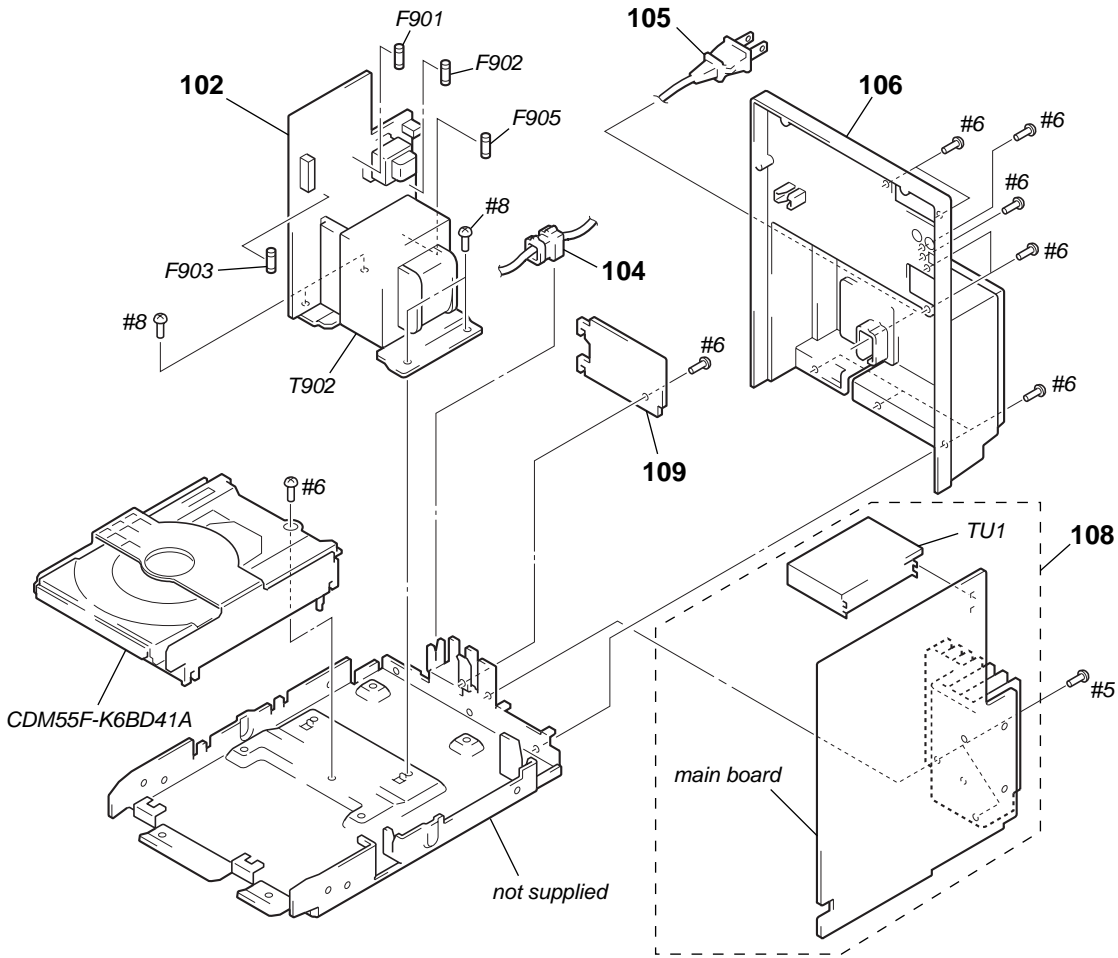

<p>The components identified by mark \triangle or dotted line with mark \triangle are critical for safety. Replace only with part number specified.</p>	<p>Les composants identifiés par une marque \triangle sont critiques pour la sécurité. Ne les remplacer que par une pièce portant le numéro spécifié.</p>
---	--

Ref. No.	Part No.	Description	Remark	Ref. No.	Part No.	Description	Remark
102	A-4728-261-A	POWER BOARD, COMPLETE (AEP, UK, AUS)		109	1-683-892-11	POWER FIXED PWB	
102	A-4729-303-A	POWER BOARD, COMPLETE (E, AR, SP)				(AEP, UK, E, AR, SP, KR, AUS)	
102	A-4729-396-A	POWER BOARD, COMPLETE (US, CND)		109	1-683-892-21	POWER FIXED PWB (US, CND, MX)	
102	A-4729-399-A	POWER BOARD, COMPLETE (MX)		F901	1-533-464-11	FUSE, GLASS TUBE (DIA. 5) (0.8A/250V)	
102	A-4730-026-A	POWER BOARD, COMPLETE (KR)				(AEP, UK, KR, AUS)	
				F901	1-576-374-11	FUSE, GLASS TUBE (1.25A/125V)	(US, CND, MX)
104	4-217-350-11	STOPPER, CORD		F902	1-533-466-11	FUSE, GLASS TUBE (DIA. 5) (1.25A/250V)	(E, AR, SP)
\triangle 105	1-696-169-11	CORD, POWER (AEP, UK, SP)					
\triangle 105	1-696-848-41	CORD, POWER (AUS)		F903	1-533-468-11	FUSE, GLASS TUBE (DIA. 5) (2A/250V)	(AEP, UK, E, AR, SP, KR, AUS)
\triangle 105	1-769-079-21	CORD, POWER (KR)					(US, CND, MX)
\triangle 105	1-775-789-91	CORD, POWER (E, MX)		F903	1-576-375-11	FUSE, GLASS TUBE (3.15A/125V)	
\triangle 105	1-783-532-11	CORD, POWER (US, CND)					
\triangle 105	1-783-941-21	CORD, POWER (AR)		F905	1-533-464-11	FUSE, GLASS TUBE (DIA. 5) (0.8A/250V)	(E, AR, SP)
106	X-4954-869-1	BACK PANEL ASSY (US, CND)		T902	1-437-248-11	TRANSFORMER, POWER (AEP, UK, KR, AUS)	
106	X-4954-871-1	BACK PANEL ASSY (MX)		T902	1-437-249-11	TRANSFORMER, POWER (US, CND, MX)	
108	A-4728-257-A	MAIN BOARD, COMPLETE (AEP, UK)					
				T902	1-437-250-11	TRANSFORMER, POWER (E, AR, SP)	
108	A-4729-302-A	MAIN BOARD, COMPLETE (SP)		TU1	A-4303-953-A	TUNER PACK (AEP, UK, KR, AUS)	
108	A-4729-305-A	MAIN BOARD, COMPLETE (E, AR)					
108	A-4729-307-A	MAIN BOARD, COMPLETE (AUS)		TU1	A-4303-954-A	TUNER PACK (US, CND, E, MX, AR, SP)	
108	A-4729-389-A	MAIN BOARD, COMPLETE (US, CND)					
108	A-4729-397-A	MAIN BOARD, COMPLETE (MX)		#5	7-685-548-19	SCREW +BTP 3X12 TYPE2 N-S	
				#6	7-685-546-14	SCREW +BTP 3X8 TYPE2 N-S	
108	A-4730-019-A	MAIN BOARD, COMPLETE (KR)					
				#8	7-685-881-09	SCREW +BVTT 4X8 (S)	

7-4. CD MECHANISM DECK (CDM55F-K6BD41A)

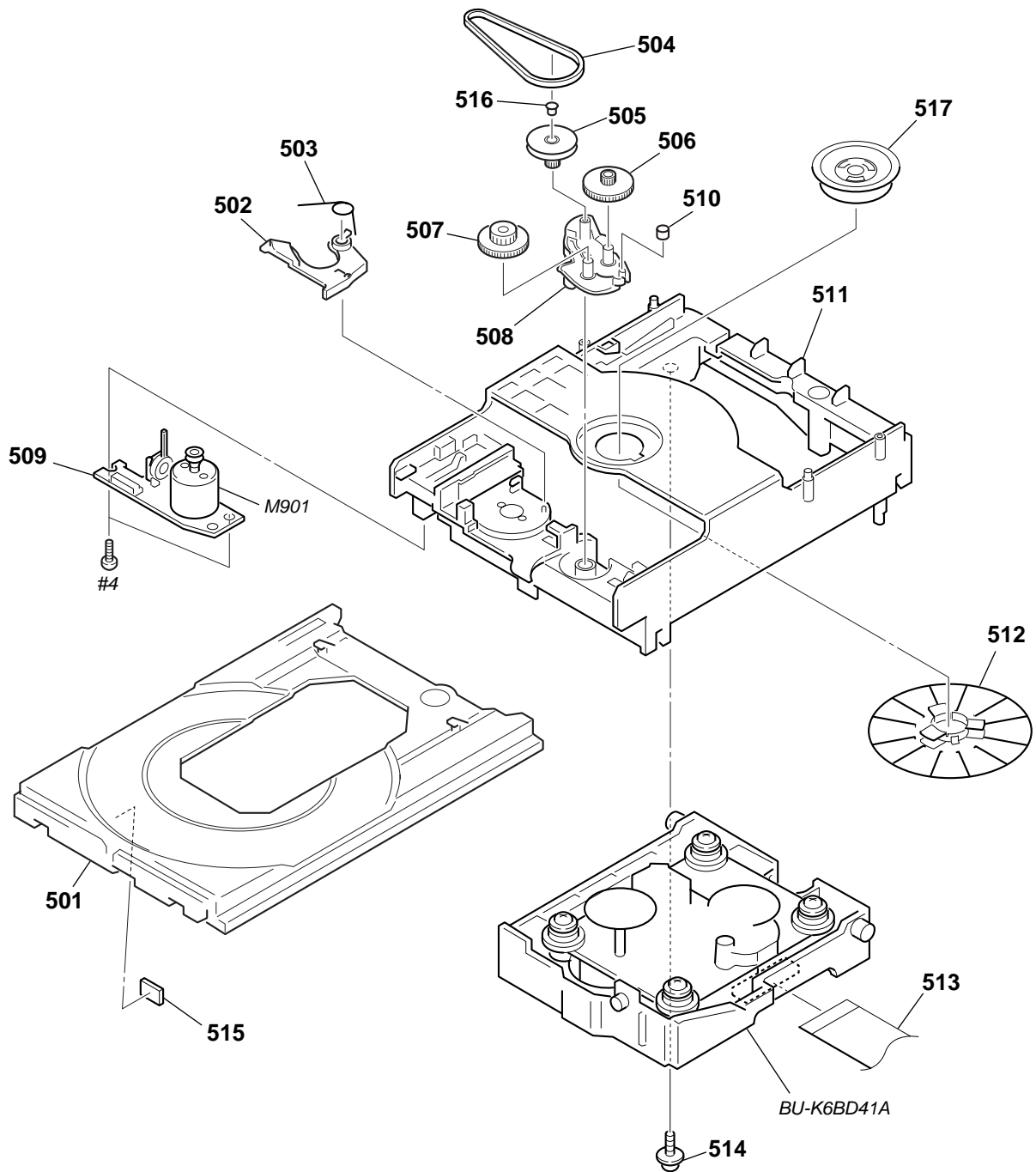

Ref. No.	Part No.	Description	Remark	Ref. No.	Part No.	Description	Remark
501	4-224-894-01	TRAY		511	4-231-779-01	CHASSIS (F)	
502	4-220-229-01	LEVER (SW)		512	A-4735-081-A	PULLEY (AT-55F) ASSY	
503	4-220-239-01	SPRING, TORSION		513	1-792-411-11	CABLE, FLEXIBLE FLAT (19 CORE)	
504	4-221-816-01	BELT (CDM55)		514	4-985-672-01	SCREW (+PTPWHM2.6), FLOATING	
505	4-220-234-01	PULLEY (LDG)		515	4-925-315-31	DAMPER	
506	4-220-237-01	GEAR (A)		516	4-227-598-01	SPACER (55)	
507	4-220-238-01	GEAR (B)		517	A-4735-082-A	MAGNET ASSY	
508	4-220-233-01	CAM (CDM55)		M901	A-2004-893-A	MOTOR (LD) ASSY (LOADING)	
509	1-681-807-11	MOTOR BOARD		#4	7-685-533-19	SCREW +BTP 2.6X6 TYPE2 N-S	
510	4-221-815-01	ROLLER					

7-5. BASE UNIT (BU-K6BD41A)

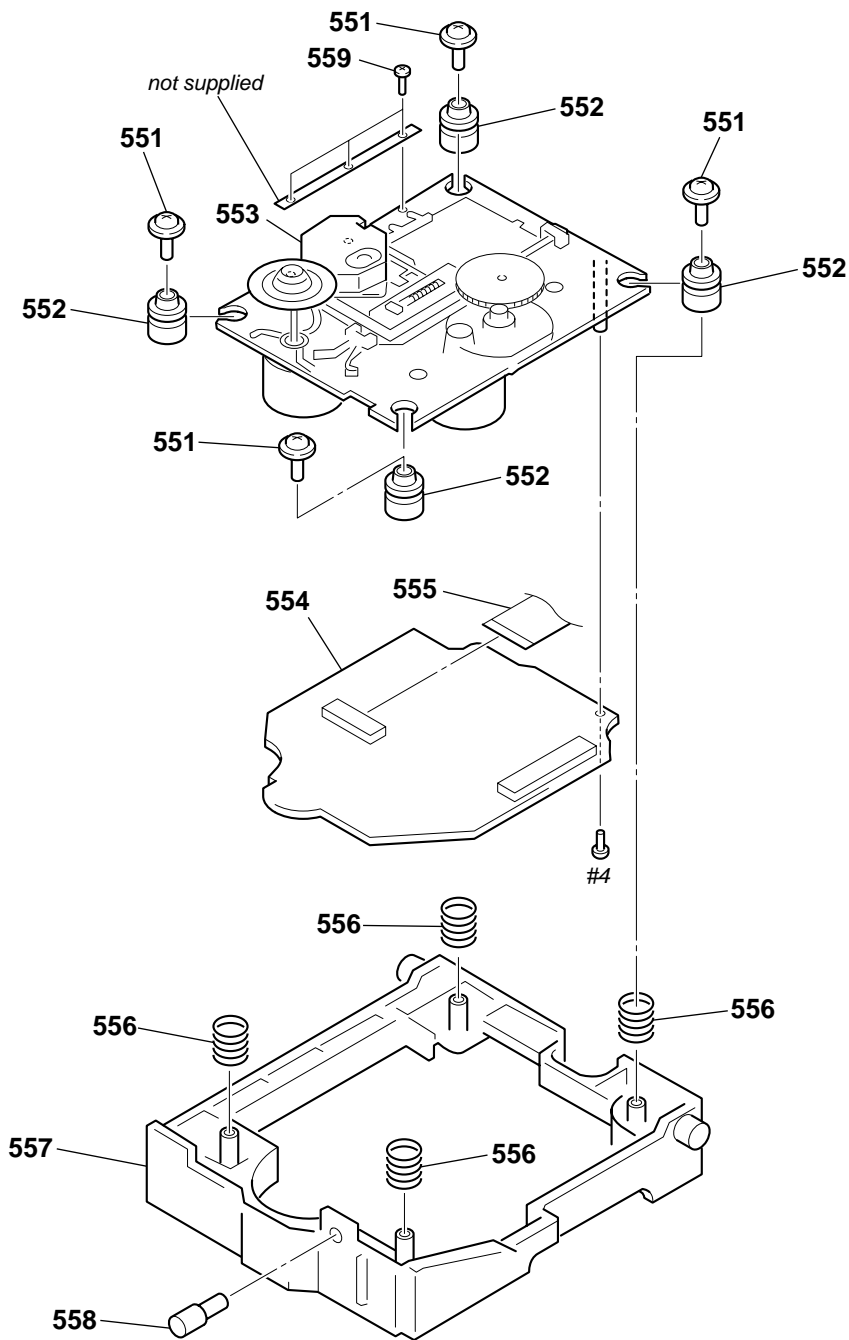

The components identified by mark \triangle or dotted line with mark \triangle are critical for safety. Replace only with part number specified.

Les composants identifiés par marque \triangle sont critiques pour la sécurité. Ne les remplacer que par une pièce portant le numéro spécifié.

Ref. No.	Part No.	Description	Remark	Ref. No.	Part No.	Description	Remark
551	4-985-672-01	SCREW (+PTPWHM2.6), FLOATING		556	4-229-004-01	SPRING, COMPRESSION	
552	4-229-005-11	INSULATOR		557	4-231-780-01	HOLDER (213D)	
\triangle 553	A-4735-357-A	OP BASE ASSY (KSM-213DHAP/ZRP1)		558	4-221-817-02	SHAFT (BU)	
554	A-4725-626-A	CD BOARD, COMPLETE		559	2-641-386-01	SCREW (2X5), TAPPING (S)	
555	1-757-055-11	WIRE, PARALLEL (FFC) (16 CORE)		#4	7-685-533-19	SCREW +BTP 2.6X6 TYPE2 N-S	

SECTION 8 ELECTRICAL PARTS LIST

CD

NOTE:

- Due to standardization, replacements in the parts list may be different from the parts specified in the diagrams or the components used on the set.
- -XX and -X mean standardized parts, so they may have some difference from the original one.
- **RESISTORS**
All resistors are in ohms.
METAL: Metal-film resistor.
METAL OXIDE: Metal oxide-film resistor.
F: nonflammable
- Abbreviation
AR : Argentina model KR : Korean model
AUS : Australian model MX : Mexican model
CND : Canadian model SP : Singapore model

- Items marked “*” are not stocked since they are seldom required for routine service. Some delay should be anticipated when ordering these items.
- **SEMICONDUCTORS**
In each case, u: μ , for example:
uA. . : μ A. . uPA. . : μ PA. .
uPB. . : μ PB. . uPC. . : μ PC. .
uPD. . : μ PD. .
- **CAPACITORS**
uF: μ F
- **COILS**
uH: μ H

The components identified by mark Δ or dotted line with mark Δ are critical for safety. Replace only with part number specified.

Les composants identifiés par une marque Δ sont critiques pour la sécurité. Ne les remplacer que par une pièce portant le numéro spécifié.

When indicating parts by reference number, please include the board.

Ref. No.	Part No.	Description	Remark	Ref. No.	Part No.	Description	Remark
	A-4725-626-A	CD BOARD, COMPLETE *****					
		< CAPACITOR >					
C101	1-162-962-11	CERAMIC CHIP	470PF 10%	50V			
C102	1-107-826-11	CERAMIC CHIP	0.1uF 10%	16V			
C103	1-162-962-11	CERAMIC CHIP	470PF 10%	50V			
C104	1-162-964-11	CERAMIC CHIP	0.001uF 10%	50V			
C108	1-107-826-11	CERAMIC CHIP	0.1uF 10%	16V			
C109	1-162-965-11	CERAMIC CHIP	0.0015uF 10%	50V			
C110	1-162-967-11	CERAMIC CHIP	0.0033uF 10%	50V			
C111	1-162-927-11	CERAMIC CHIP	100PF 5%	50V			
C112	1-107-826-11	CERAMIC CHIP	0.1uF 10%	16V			
C114	1-164-360-11	CERAMIC CHIP	0.1uF	16V			
C115	1-126-382-11	ELECT	100uF 20%	16V			
C116	1-126-382-11	ELECT	100uF 20%	16V			
C117	1-126-382-11	ELECT	100uF 20%	16V			
C118	1-162-964-11	CERAMIC CHIP	0.001uF 10%	50V			
C119	1-162-919-11	CERAMIC CHIP	22PF 5%	50V			
C121	1-164-360-11	CERAMIC CHIP	0.1uF	16V			
C122	1-126-382-11	ELECT	100uF 20%	16V			
C123	1-162-970-11	CERAMIC CHIP	0.01uF 10%	25V			
C124	1-125-891-11	CERAMIC CHIP	0.47uF 10%	10V			
C125	1-164-360-11	CERAMIC CHIP	0.1uF	16V			
C126	1-164-360-11	CERAMIC CHIP	0.1uF	16V			
C127	1-126-382-11	ELECT	100uF 20%	16V			
C129	1-162-970-11	CERAMIC CHIP	0.01uF 10%	25V			
C130	1-115-156-11	CERAMIC CHIP	1uF	10V			
C131	1-124-233-11	ELECT	10uF 20%	16V			
C133	1-115-156-11	CERAMIC CHIP	1uF	10V			
C140	1-115-156-11	CERAMIC CHIP	1uF	10V			
C141	1-115-156-11	CERAMIC CHIP	1uF	10V			
C143	1-164-360-11	CERAMIC CHIP	0.1uF	16V			
C145	1-164-360-11	CERAMIC CHIP	0.1uF	16V			
C146	1-162-964-11	CERAMIC CHIP	0.001uF 10%	50V			
C147	1-162-964-11	CERAMIC CHIP	0.001uF 10%	50V			
C148	1-162-927-11	CERAMIC CHIP	100PF 5%	50V			
C153	1-164-360-11	CERAMIC CHIP	0.1uF	16V			
C159	1-162-969-11	CERAMIC CHIP	0.0068uF 10%	25V			
C160	1-124-257-00	ELECT	2.2uF 20%	50V			
C162	1-126-382-11	ELECT	100uF 20%	16V			
C163	1-126-382-11	ELECT	100uF 20%	16V			
C165	1-164-360-11	CERAMIC CHIP	0.1uF	16V			
C167	1-162-920-11	CERAMIC CHIP	27PF 5%	50V			
C168	1-162-919-11	CERAMIC CHIP	22PF 5%	50V			
C171	1-162-964-11	CERAMIC CHIP	0.001uF 10%	50V			
C172	1-164-218-11	CERAMIC CHIP	180PF 0.25PF	50V			
C181	1-162-964-11	CERAMIC CHIP	0.001uF 10%	50V			
C182	1-164-218-11	CERAMIC CHIP	180PF 0.25PF	50V			
		< CONNECTOR >					
CN101	1-691-078-41	HOUSING, CONNECTOR	19P				
CN102	1-785-953-11	CONNECTOR, FFC/FPC	16P				
		< FERRITE BEAD >					
FB101	1-469-144-21	FERRITE	0uH				
FB102	1-469-144-21	FERRITE	0uH				
FB103	1-469-144-21	FERRITE	0uH				
FB104	1-469-144-21	FERRITE	0uH				
		< IC >					
IC101	8-752-386-85	IC	CXD2587Q				
IC102	8-759-549-28	IC	BA5974FP-E2				
IC103	8-752-085-51	IC	CXA2568M-T6				
		< COIL >					
L101	1-410-993-11	INDUCTOR CHIP	1uH				
		< TRANSISTOR >					
Q101	8-729-010-08	TRANSISTOR	MSB710-R				
		< RESISTOR >					
R101	1-216-835-11	METAL CHIP	15K 5%	1/10W			
R102	1-216-845-11	METAL CHIP	100K 5%	1/10W			
R103	1-216-835-11	METAL CHIP	15K 5%	1/10W			
R104	1-216-839-11	METAL CHIP	33K 5%	1/10W			
R105	1-216-833-11	METAL CHIP	10K 5%	1/10W			
R106	1-216-821-11	METAL CHIP	1K 5%	1/10W			
R107	1-216-833-11	METAL CHIP	10K 5%	1/10W			
R108	1-216-827-11	METAL CHIP	3.3K 5%	1/10W			
R109	1-216-857-11	METAL CHIP	1M 5%	1/10W			
R110	1-216-809-11	METAL CHIP	100 5%	1/10W			
R111	1-216-857-11	METAL CHIP	1M 5%	1/10W			
R113	1-216-857-11	METAL CHIP	1M 5%	1/10W			
R114	1-216-833-11	METAL CHIP	10K 5%	1/10W			
R116	1-216-797-11	METAL CHIP	10 5%	1/10W			
R117	1-216-821-11	METAL CHIP	1K 5%	1/10W			

HCD-CP101
Ver 1.2

CD	CD INDICATOR	CONTROL (A)
----	--------------	-------------

Ref. No.	Part No.	Description	Quantity	Power	Remark
R118	1-216-809-11	METAL CHIP	100	5%	1/10W
R119	1-216-817-11	METAL CHIP	470	5%	1/10W
R123	1-216-833-11	METAL CHIP	10K	5%	1/10W
R124	1-216-845-11	METAL CHIP	100K	5%	1/10W
R131	1-216-809-11	METAL CHIP	100	5%	1/10W
R132	1-216-863-11	RES-CHIP	3.3M	5%	1/10W
R143	1-216-848-11	METAL CHIP	180K	5%	1/10W
R144	1-216-848-11	METAL CHIP	180K	5%	1/10W
R147	1-218-867-11	RES-CHIP	6.8K	5%	1/10W
R148	1-216-797-11	METAL CHIP	10	5%	1/10W
R149	1-216-797-11	METAL CHIP	10	5%	1/10W
R158	1-216-852-11	METAL CHIP	390K	5%	1/10W
R159	1-216-847-11	METAL CHIP	150K	5%	1/10W
R160	1-216-833-11	METAL CHIP	10K	5%	1/10W
R161	1-216-821-11	METAL CHIP	1K	5%	1/10W
R162	1-216-847-11	METAL CHIP	150K	5%	1/10W
R171	1-218-291-11	RES-CHIP	16K	5%	1/10W
R172	1-216-833-11	METAL CHIP	10K	5%	1/10W
R173	1-216-835-11	METAL CHIP	15K	5%	1/10W
R181	1-218-291-11	RES-CHIP	16K	5%	1/10W
R182	1-216-833-11	METAL CHIP	10K	5%	1/10W
R183	1-216-835-11	METAL CHIP	15K	5%	1/10W
< COMPOSITION CIRCUIT BLOCK >					
RN101	1-233-576-11	RES, CHIP NETWORK 100			
< SWITCH >					
S101	1-771-853-11	SWITCH, DETECTION (LIMIT)			
< VIBRATOR >					
X101	1-781-947-11	VIBRATOR, CRYSTAL (16.9344MHz)			

	1-683-893-11	CD INDICATOR BOARD (AEP, UK, E, SP, AR, KR, AUS)			
	1-683-893-21	CD INDICATOR BOARD (US, CND, MX)			

< CONNECTOR >					
CN806	1-506-481-11	PIN, CONNECTOR 2P			
< LED >					
D860	6-500-076-01	LED SLI-343YC (DISC TRAY ILLUMINATION)			
D861	6-500-076-01	LED SLI-343YC (DISC TRAY ILLUMINATION)			
D863	6-500-076-01	LED SLI-343YC (DISC TRAY ILLUMINATION)			
< RESISTOR >					
R682	1-247-807-11	CARBON	100	5%	1/4W

Ref. No.	Part No.	Description	Quantity	Power	Remark
CONTROL (A) BOARD, COMPLETE (AEP, UK, E, SP, AR, AUS)					
CONTROL (A) BOARD, COMPLETE (US, CND, MX)					
CONTROL (A) BOARD, COMPLETE (KR)					

< CAPACITOR >					
C612	1-165-176-11	CERAMIC CHIP	0.047uF	10%	16V
C613	1-165-176-11	CERAMIC CHIP	0.047uF	10%	16V
C614	1-162-970-11	CERAMIC CHIP	0.01uF	10%	25V
C615	1-126-963-11	ELECT	4.7uF	20%	50V
< CONNECTOR >					
CN805	1-784-781-11	CONNECTOR, FFC 20P			
* CN809	1-568-943-11	PIN, CONNECTOR 5P			
< LED >					
D851	8-719-074-42	LED SLR325VR-T31 (STANDBY)			
D852	6-500-076-01	LED SLI-343YC (▷ ▢▢)			
D853	6-500-076-01	LED SLI-343YC (▷ ▢▢)			
D856	6-500-076-01	LED SLI-343YC (BAND)			
D857	6-500-076-01	LED SLI-343YC (BAND)			
D858	8-719-060-26	LED SLR-325YCT31 (DSG)			
< IC >					
IC802	8-759-827-70	IC NJL64H400A-1			
< RESISTOR >					
JR601	1-216-864-11	METAL CHIP	0	5%	1/10W
JR602	1-216-864-11	METAL CHIP	0	5%	1/10W
< TRANSISTOR >					
Q851	8-729-900-53	TRANSISTOR	DTC114EKA-T146		
Q852	8-729-900-53	TRANSISTOR	DTC114EKA-T146		
Q854	8-729-900-53	TRANSISTOR	DTC114EKA-T146		
Q855	8-729-900-53	TRANSISTOR	DTC114EKA-T146		
Q856	8-729-900-53	TRANSISTOR	DTC114EKA-T146		
Q857	8-729-900-53	TRANSISTOR	DTC114EKA-T146		
< RESISTOR >					
R600	1-216-833-11	METAL CHIP	10K	5%	1/10W
R624	1-216-829-11	METAL CHIP	4.7K	5%	1/10W
R651	1-216-841-11	METAL CHIP	47K	5%	1/10W
R652	1-216-837-11	METAL CHIP	22K	5%	1/10W
R653	1-216-833-11	METAL CHIP	10K	5%	1/10W
R654	1-216-829-11	METAL CHIP	4.7K	5%	1/10W
R655	1-216-825-11	METAL CHIP	2.2K	5%	1/10W
R656	1-216-825-11	METAL CHIP	2.2K	5%	1/10W
R657	1-216-821-11	METAL CHIP	1K	5%	1/10W
R659	1-216-833-11	METAL CHIP	10K	5%	1/10W
R667	1-216-845-11	METAL CHIP	100K	5%	1/10W
R668	1-216-845-11	METAL CHIP	100K	5%	1/10W
R669	1-216-845-11	METAL CHIP	100K	5%	1/10W
R670	1-216-845-11	METAL CHIP	100K	5%	1/10W
R671	1-216-845-11	METAL CHIP	100K	5%	1/10W
R672	1-216-845-11	METAL CHIP	100K	5%	1/10W

CONTROL (A)

CONTROL (B)

HEADPHONE

LCD

Ref. No.	Part No.	Description	Remark
R675	1-216-833-11	METAL CHIP 10K 5%	1/10W
R676	1-216-829-11	METAL CHIP 4.7K 5%	1/10W
R677	1-216-818-11	METAL CHIP 560 5%	1/10W
R679	1-216-815-11	METAL CHIP 330 5%	1/10W
R684	1-216-825-11	METAL CHIP 2.2K 5%	1/10W
R685	1-216-825-11	METAL CHIP 2.2K 5%	1/10W
R686	1-216-821-11	METAL CHIP 1K 5%	1/10W
R687	1-216-816-11	METAL CHIP 390 5%	1/10W
R689	1-216-841-11	METAL CHIP 47K 5%	1/10W
R690	1-216-837-11	METAL CHIP 22K 5%	1/10W
R691	1-216-833-11	METAL CHIP 10K 5%	1/10W
R692	1-216-829-11	METAL CHIP 4.7K 5%	1/10W
R698	1-216-816-11	METAL CHIP 390 5%	1/10W
< ROTARY ENCODER >			
RV801	1-473-392-11	ENCODER, ROTARY (VOLUME)	
RV802	1-418-859-11	ENCODER, ROTARY (TREBLE)	
RV803	1-418-859-11	ENCODER, ROTARY (BASS)	
< SWITCH >			
S801	1-786-220-11	SWITCH, KEY BOARD (I/⏻)	
S802	1-786-220-11	SWITCH, KEY BOARD (▷ ⏻)	
S803	1-786-220-11	SWITCH, KEY BOARD (□)	
S804	1-786-220-11	SWITCH, KEY BOARD (▶▶ ▶▶▶)	
S805	1-786-220-11	SWITCH, KEY BOARD (◀◀ ◀◀◀)	
S806	1-786-220-11	SWITCH, KEY BOARD (PLAY MODE)	
S807	1-786-220-11	SWITCH, KEY BOARD (REPEAT)	
S808	1-786-220-11	SWITCH, KEY BOARD (▲)	
S816	1-786-220-11	SWITCH, KEY BOARD (BAND)	
S817	1-786-220-11	SWITCH, KEY BOARD (DSG)	
S818	1-786-220-11	SWITCH, KEY BOARD (TUNING +)	
S819	1-786-220-11	SWITCH, KEY BOARD (TUNING -)	
S820	1-786-220-11	SWITCH, KEY BOARD (TUNING MODE)	
S821	1-786-220-11	SWITCH, KEY BOARD (FUNCTION)	

A-4728-262-A	CONTROL (B) BOARD, COMPLETE (AEP, UK, E, SP, AR, KR, AUS)		
A-4729-394-A	CONTROL (B) BOARD, COMPLETE (US, CND, MX)		
A-4730-024-A	CONTROL (B) BOARD, COMPLETE (KR)		

< LED >			
D854	6-500-076-01	LED SLI-343YC (◀ ▷)	
D855	6-500-076-01	LED SLI-343YC (◀ ▷)	
D859	8-719-074-42	LED SLR325VR-T31 (CD SYNC)	
< TRANSISTOR >			
Q853	8-729-900-53	TRANSISTOR DTC114EKA-T146	
< RESISTOR >			
R660	1-216-825-11	METAL CHIP 2.2K 5%	1/10W
R661	1-216-825-11	METAL CHIP 2.2K 5%	1/10W
R662	1-216-829-11	METAL CHIP 4.7K 5%	1/10W
R663	1-216-833-11	METAL CHIP 10K 5%	1/10W
R664	1-216-837-11	METAL CHIP 22K 5%	1/10W
R665	1-216-841-11	METAL CHIP 47K 5%	1/10W
R666	1-216-821-11	METAL CHIP 1K 5%	1/10W

Ref. No.	Part No.	Description	Remark
R680	1-216-820-11	METAL CHIP 820 5%	1/10W
R697	1-216-816-11	METAL CHIP 390 5%	1/10W
< SWITCH >			
S809	1-786-220-11	SWITCH, KEY BOARD (◀ ▷)	
S810	1-786-220-11	SWITCH, KEY BOARD (□)	
S811	1-786-220-11	SWITCH, KEY BOARD (▶▶)	
S812	1-786-220-11	SWITCH, KEY BOARD (◀◀)	
S813	1-786-220-11	SWITCH, KEY BOARD (■)	
S814	1-786-220-11	SWITCH, KEY BOARD (● REC)	
S815	1-786-220-11	SWITCH, KEY BOARD (CD SYNC)	

1-683-891-11	HEADPHONE BOARD (AEP, UK, E, SP, AR, KR, AUS)		
1-683-891-21	HEADPHONE BOARD (US, CND, MX)		

< CAPACITOR >			
C161	1-164-227-11	CERAMIC CHIP 0.022uF 10%	25V
C261	1-164-227-11	CERAMIC CHIP 0.022uF 10%	25V
< FERRITE BEAD >			
FB101	1-414-813-11	FERRITE 0uH (US, CND, MX)	
FB201	1-414-813-11	FERRITE 0uH (US, CND, MX)	
FB303	1-414-813-11	FERRITE 0uH (US, CND, MX)	
< JACK >			
J301	1-794-453-11	JACK (PHONES)	
< COIL >			
L102	1-412-002-31	INDUCTOR 4.7uH	
L202	1-412-002-31	INDUCTOR 4.7uH	
L307	1-410-997-42	INDUCTOR 2.2uH (US, CND, MX)	

1-683-890-11	LCD BOARD (AEP, UK, E, SP, AR, KR, AUS)		
1-683-890-21	LCD BOARD (US, CND, MX)		

< CONNECTOR >			
CN803	1-785-952-11	CONNECTOR, FFC/FPC (ZIF) 20P	
CN810	1-785-951-11	CONNECTOR, FFC/FPC (ZIF) 18P	
< LED >			
D866	8-719-085-55	LED SY3318-V-L (LCD BACK LIGHT)	
D867	8-719-085-55	LED SY3318-V-L (LCD BACK LIGHT)	
D868	8-719-085-55	LED SY3318-V-L (LCD BACK LIGHT)	
D869	8-719-085-55	LED SY3318-V-L (LCD BACK LIGHT)	
< LIQUID CRYSTAL DISPLAY >			
LCD801	1-803-542-21	DISPLAY PANEL, LIQUID CRYSTAL	
< RESISTOR >			
R627	1-249-407-11	CARBON 150 5%	1/4W
R628	1-249-407-11	CARBON 150 5%	1/4W

MAIN

Ref. No.	Part No.	Description	Remark
	A-4728-257-A	MAIN BOARD, COMPLETE (AEP, UK)	
	A-4729-302-A	MAIN BOARD, COMPLETE (SP)	
	A-4729-305-A	MAIN BOARD, COMPLETE (E, AR)	
	A-4729-307-A	MAIN BOARD, COMPLETE (AUS)	
	A-4729-389-A	MAIN BOARD, COMPLETE (US, CND)	
	A-4729-397-A	MAIN BOARD, COMPLETE (MX)	
	A-4730-019-A	MAIN BOARD, COMPLETE (KR)	

	4-217-354-11	BUSHING, INSULATING	
	4-230-078-01	SCREW, +BV TAPPING	
	7-685-546-14	SCREW +BTP 3X8 TYPE2 N-S	
	7-685-647-79	SCREW +BVTP 3X10 TYPE2 N-S	
		< CAPACITOR >	
C101	1-126-963-11	ELECT 4.7uF	20% 50V
C102	1-126-963-11	ELECT 4.7uF	20% 50V
C103	1-126-963-11	ELECT 4.7uF	20% 50V
C104	1-126-963-11	ELECT 4.7uF	20% 50V
C105	1-126-963-11	ELECT 4.7uF	20% 50V
C106	1-126-963-11	ELECT 4.7uF	20% 50V
C107	1-162-965-11	CERAMIC CHIP 0.0015uF	10% 50V
C108	1-164-156-11	CERAMIC CHIP 0.1uF	25V
C109	1-115-467-11	CERAMIC CHIP 0.22uF	10% 10V
C110	1-115-156-11	CERAMIC CHIP 1uF	10V
C114	1-126-963-11	ELECT 4.7uF	20% 50V
C115	1-115-467-11	CERAMIC CHIP 0.22uF	10% 10V
C117	1-162-927-11	CERAMIC CHIP 100PF	5% 50V
C130	1-162-927-11	CERAMIC CHIP 100PF	5% 50V
C131	1-126-963-11	ELECT 4.7uF	20% 50V
C140	1-126-963-11	ELECT 4.7uF	20% 50V
C141	1-126-947-11	ELECT 47uF	20% 35V
C142	1-162-962-11	CERAMIC CHIP 470PF	10% 50V
C143	1-126-965-11	ELECT 22uF	20% 35V
C144	1-130-495-00	MYLAR 0.1uF	5% 50V
C145	1-130-495-00	MYLAR 0.1uF	5% 50V
C160	1-126-933-11	ELECT 100uF	20% 16V
C170	1-162-970-11	CERAMIC CHIP 0.01uF	10% 25V
C170	1-164-227-11	CERAMIC CHIP 0.022uF	10% 25V (E, SP, AR) (EXCEPT E, SP, AR)
C201	1-126-963-11	ELECT 4.7uF	20% 50V
C202	1-126-963-11	ELECT 4.7uF	20% 50V
C203	1-126-963-11	ELECT 4.7uF	20% 50V
C204	1-126-963-11	ELECT 4.7uF	20% 50V
C205	1-126-963-11	ELECT 4.7uF	20% 50V
C206	1-126-963-11	ELECT 4.7uF	20% 50V
C207	1-162-965-11	CERAMIC CHIP 0.0015uF	10% 50V
C208	1-164-156-11	CERAMIC CHIP 0.1uF	25V
C209	1-115-467-11	CERAMIC CHIP 0.22uF	10% 10V
C210	1-115-156-11	CERAMIC CHIP 1uF	10V
C214	1-126-963-11	ELECT 4.7uF	20% 50V
C215	1-115-467-11	CERAMIC CHIP 0.22uF	10% 10V
C217	1-162-927-11	CERAMIC CHIP 100PF	5% 50V
C230	1-162-927-11	CERAMIC CHIP 100PF	5% 50V
C231	1-126-963-11	ELECT 4.7uF	20% 50V
C240	1-126-963-11	ELECT 4.7uF	20% 50V
C241	1-126-947-11	ELECT 47uF	20% 35V
C242	1-162-962-11	CERAMIC CHIP 470PF	10% 50V

Ref. No.	Part No.	Description	Remark
C243	1-126-965-11	ELECT 22uF	20% 35V
C244	1-130-495-00	MYLAR 0.1uF	5% 50V
C245	1-130-495-00	MYLAR 0.1uF	5% 50V
C260	1-126-933-11	ELECT 100uF	20% 16V
C270	1-162-970-11	CERAMIC CHIP 0.01uF	10% 25V
C270	1-164-227-11	CERAMIC CHIP 0.022uF	10% 25V (E, SP, AR) (EXCEPT E, SP, AR)
C301	1-126-965-11	ELECT 22uF	20% 50V
C302	1-162-964-11	CERAMIC CHIP 0.001uF	10% 50V
C303	1-162-927-11	CERAMIC CHIP 100PF	5% 50V
C304	1-126-933-11	ELECT 100uF	20% 16V
C305	1-126-947-11	ELECT 47uF	20% 16V
C306	1-162-964-11	ELECT 10uF	20% 50V
C307	1-126-963-11	ELECT 4.7uF	20% 50V
C308	1-126-860-61	ELECT 3300uF	20% 35V
C309	1-126-860-61	ELECT 3300uF	20% 35V
C310	1-126-944-11	ELECT 3300uF	20% 25V
C311	1-164-156-11	CERAMIC CHIP 0.1uF	25V
C312	1-126-934-11	ELECT 220uF	20% 10V
C313	1-162-964-11	CERAMIC CHIP 0.001uF	10% 50V
C314	1-164-156-11	CERAMIC CHIP 0.1uF	25V
C315	1-126-947-11	ELECT 47uF	20% 16V
C316	1-164-156-11	CERAMIC CHIP 0.1uF	25V
C317	1-164-156-11	CERAMIC CHIP 0.1uF	25V
C318	1-126-935-11	ELECT 470uF	20% 16V
C319	1-126-964-11	ELECT 10uF	20% 50V
C320	1-162-927-11	CERAMIC CHIP 100PF	5% 50V
C321	1-164-156-11	CERAMIC CHIP 0.1uF	25V
C322	1-126-934-11	ELECT 220uF	20% 10V
C323	1-164-156-11	CERAMIC CHIP 0.1uF	25V
C324	1-126-935-11	ELECT 470uF	20% 16V
C325	1-162-927-11	CERAMIC CHIP 100PF	5% 50V
C328	1-126-933-11	ELECT 100uF	20% 16V
C329	1-126-935-11	ELECT 470uF	20% 16V
C330	1-164-156-11	CERAMIC CHIP 0.1uF	25V
C331	1-126-934-11	ELECT 220uF	20% 10V
C332	1-126-926-11	ELECT 1000uF	20% 10V
C333	1-162-964-11	CERAMIC CHIP 0.001uF	10% 50V
C339	1-126-935-11	ELECT 470uF	20% 16V
C340	1-126-964-11	ELECT 10uF	20% 50V
C341	1-164-156-11	CERAMIC CHIP 0.1uF	25V
C342	1-107-826-11	CERAMIC CHIP 0.1uF	10% 16V
C343	1-107-826-11	CERAMIC CHIP 0.1uF	10% 16V
C344	1-107-826-11	CERAMIC CHIP 0.1uF	10% 16V
C345	1-104-665-11	ELECT 100uF	20% 10V
C346	1-164-156-11	CERAMIC CHIP 0.1uF	25V
C347	1-126-964-11	ELECT 10uF	20% 50V
C360	1-126-947-11	ELECT 47uF	20% 16V
C361	1-162-970-11	CERAMIC CHIP 0.01uF	10% 25V
C365	1-126-934-11	ELECT 220uF	20% 10V
C368	1-164-156-11	CERAMIC CHIP 0.1uF	25V
C370	1-162-964-11	CERAMIC CHIP 0.001uF	10% 50V
C371	1-107-826-11	CERAMIC CHIP 0.1uF	10% 16V
C372	1-162-962-11	CERAMIC CHIP 470PF	10% 50V (EXCEPT US, CND, MX)
C373	1-162-964-11	CERAMIC CHIP 0.001uF	10% 50V

Ref. No.	Part No.	Description	Remark	Ref. No.	Part No.	Description	Remark
C374	1-107-826-11	CERAMIC CHIP	0.1uF 10% 16V (US, CND, MX)	D601	8-719-200-82	DIODE 11ES2-TA1B	
C375	1-162-294-31	CERAMIC	0.001uF 10% 50V	D602	8-719-200-82	DIODE 11ES2-TA1B	
C380	1-162-964-11	CERAMIC CHIP	0.001uF 10% 50V (US, CND, MX)	D801	8-719-991-33	DIODE 1SS133T-77	
C501	1-104-665-11	ELECT	100uF 20% 10V	D802	8-719-991-33	DIODE 1SS133T-77	
C502	1-104-665-11	ELECT	100uF 20% 10V	D805	8-719-982-11	DIODE MTZJ-T-77-4.3B (AEP, UK)	
C600	1-162-927-11	CERAMIC CHIP	100PF 5% 50V	D806	8-719-991-33	DIODE 1SS133T-77 (AEP, UK)	
C603	1-107-826-11	CERAMIC CHIP	0.1uF 10% 16V (AEP, UK)	D807	8-719-991-33	DIODE 1SS133T-77	
C604	1-126-947-11	ELECT	47uF 20% 10V (AEP, UK)	D808	8-719-991-33	DIODE 1SS133T-77	
C605	1-164-185-11	CERAMIC CHIP	13PF 5% 50V (AEP, UK)	D811	8-719-991-33	DIODE 1SS133T-77	
C606	1-164-185-11	CERAMIC CHIP	13PF 5% 50V (AEP, UK)	D812	8-719-991-33	DIODE 1SS133T-77	
C607	1-162-970-11	CERAMIC CHIP	0.01uF 10% 25V (AEP, UK)	< FERRITE BEAD >			
C608	1-162-961-11	CERAMIC CHIP	330PF 10% 50V (AEP, UK)	FB301	1-414-813-11	FERRITE 0uH	
C609	1-164-739-11	CERAMIC CHIP	560PF 5% 50V (AEP, UK)	FB302	1-414-813-11	FERRITE 0uH	
C610	1-126-963-11	ELECT	4.7uF 20% 50V (AEP, UK)	< IC >			
C611	1-162-927-11	CERAMIC CHIP	100PF 5% 50V (AEP, UK)	IC101	8-759-584-38	IC TDA7296	
C800	1-162-970-11	CERAMIC CHIP	0.01uF 10% 25V	IC201	8-759-584-38	IC TDA7296	
C803	1-162-975-11	CERAMIC CHIP	24PF 5% 50V	IC301	8-759-646-52	IC KIA7805API	
C804	1-162-975-11	CERAMIC CHIP	24PF 5% 50V	IC304	8-759-646-54	IC KIA7808API	
C805	1-115-156-11	CERAMIC CHIP	1uF 10V	IC306	8-759-646-54	IC KIA7808API	
C806	1-115-156-11	CERAMIC CHIP	1uF 10V	IC320	8-759-822-09	IC LB1641	
C807	1-107-826-11	CERAMIC CHIP	0.1uF 10% 16V	IC321	8-749-923-04	IC TOTX178A (OPTICAL DIGITAL OUT (CD))	
C808	1-107-826-11	CERAMIC CHIP	0.1uF 10% 16V	IC323	8-759-669-03	IC LC75342	
C809	1-107-826-11	CERAMIC CHIP	0.1uF 10% 16V	IC324	8-759-359-49	IC NJM3414AV (TE2)	
C810	1-115-456-21	DOUBLE LAYER	0.22F 5.5V	IC801	8-752-932-07	IC CXP83124A-055Q	
C811	1-162-919-11	CERAMIC CHIP	22PF 5% 50V	IC803	8-759-652-68	IC BMR-0301H	
C812	1-162-920-11	CERAMIC CHIP	27PF 5% 50V	IC804	8-759-557-36	IC BU1924F-E2 (AEP, UK)	
C813	1-126-964-11	ELECT	10uF 20% 50V	< RESISTOR >			
C814	1-162-970-11	CERAMIC CHIP	0.01uF 10% 25V	JR300	1-216-864-11	METAL CHIP 0 5% 1/10W	
< CONNECTOR >				JR301	1-216-864-11	METAL CHIP 0 5% 1/10W	
CN101	1-784-780-11	CONNECTOR, FFC 19P		JR302	1-216-864-11	METAL CHIP 0 5% 1/10W	
CN301	1-784-778-11	CONNECTOR, FFC 17P		JR303	1-216-864-11	METAL CHIP 0 5% 1/10W	
* CN303	1-506-984-11	PIN, CONNECTOR (PC BOARD) 2P		< COIL >			
* CN401	1-568-954-11	PIN, CONNECTOR 5P		L101	1-422-009-13	COIL, AIR-CORE	
CN501	1-506-469-11	PIN, CONNECTOR 4P		L201	1-422-009-13	COIL, AIR-CORE	
CN801	1-779-288-11	CONNECTOR, FFC (LIF (NON-ZIF)) 20P		L301	1-410-324-11	INDUCTOR 4.7uH	
CN802	1-779-286-11	CONNECTOR, FFC (LIF (NON-ZIF)) 18P		L304	1-414-137-31	INDUCTOR 0.22uH	
CN804	1-785-949-11	CONNECTOR, FFC/FPC 20P		L305	1-410-750-41	INDUCTOR 0.47uH	
< DIODE >				L306	1-410-985-11	INDUCTOR 0.22uH (AEP, UK)	
D301	8-719-914-42	DIODE DA204K-T-146		L306	1-410-985-42	INDUCTOR 0.22uH (EXCEPT AEP, UK)	
D303	8-719-200-82	DIODE 11ES2-TA1B		< TRANSISTOR >			
D304	8-719-921-42	DIODE MTZJ-5.1A		Q100	8-729-920-31	TRANSISTOR DTC343TK-T-146	
D305	8-719-110-17	DIODE MTZJ-T-77-10B		Q200	8-729-920-31	TRANSISTOR DTC343TK-T-146	
D307	8-719-110-17	DIODE MTZJ-T-77-10B		Q301	8-729-028-54	TRANSISTOR KTC3205-Y-AT	
D308	8-719-109-89	DIODE MTZJ-T-77-5.6B		Q303	8-729-038-54	TRANSISTOR KRA102S	
D309	8-719-110-08	DIODE MTZJ-T-77-8.2B		Q304	8-729-038-68	TRANSISTOR KRC103S	
D310	8-719-200-82	DIODE 11ES2-TA1B		Q305	8-729-019-00	TRANSISTOR KTC2026	
D311	8-719-110-31	DIODE MTZJ-T-77-12B		Q306	8-729-019-00	TRANSISTOR KTC2026	
				Q307	8-729-038-54	TRANSISTOR KRA102S	
				Q308	8-729-038-68	TRANSISTOR KRC103S	
				Q310	8-729-038-67	TRANSISTOR KRC102S	
				Q312	8-729-038-68	TRANSISTOR KRC103S	
				Q313	8-729-038-54	TRANSISTOR KRA102S	

MAIN

Ref. No.	Part No.	Description	Remark	Ref. No.	Part No.	Description	Remark
Q330	8-729-038-68	TRANSISTOR	KRC103S	R160	1-216-805-11	METAL CHIP	47 5% 1/10W
Q355	8-729-019-00	TRANSISTOR	KTC2026	R201	1-216-829-11	METAL CHIP	4.7K 5% 1/10W
Q501	8-729-036-89	TRANSISTOR	KTC3198GR-A	R202	1-216-821-11	METAL CHIP	1K 5% 1/10W
Q502	8-729-036-89	TRANSISTOR	KTC3198GR-A	R203	1-216-833-11	METAL CHIP	10K 5% 1/10W
Q601	8-729-202-56	TRANSISTOR	2SA950-Y-TPE2	R204	1-216-825-11	METAL CHIP	2.2K 5% 1/10W
Q602	8-729-038-67	TRANSISTOR	KRC102S	R205	1-216-825-11	METAL CHIP	2.2K 5% 1/10W
Q603	8-729-038-67	TRANSISTOR	KRC102S	R206	1-216-827-11	METAL CHIP	3.3K 5% 1/10W
Q604	8-729-202-56	TRANSISTOR	2SA950-Y-TPE2	R207	1-218-867-11	RES-CHIP	6.8K 5% 1/10W
Q605	8-729-038-67	TRANSISTOR	KRC102S	R213	1-216-829-11	METAL CHIP	4.7K 5% 1/10W
Q606	8-729-038-67	TRANSISTOR	KRC102S	R214	1-216-841-11	METAL CHIP	47K 5% 1/10W
Q607	8-729-801-84	TRANSISTOR	2SB1013-TP-34	R218	1-216-821-11	METAL CHIP	1K 5% 1/10W
Q608	8-729-801-84	TRANSISTOR	2SB1013-TP-34	R220	1-216-829-11	METAL CHIP	4.7K 5% 1/10W
Q609	8-729-038-67	TRANSISTOR	KRC102S	R221	1-216-849-11	METAL CHIP	220K 5% 1/10W
Q802	8-729-038-67	TRANSISTOR	KRC102S	R222	1-216-829-11	METAL CHIP	4.7K 5% 1/10W
Q803	8-729-038-67	TRANSISTOR	KRC102S	R223	1-216-837-11	METAL CHIP	22K 5% 1/10W
Q804	8-729-038-67	TRANSISTOR	KRC102S	R232	1-216-833-11	METAL CHIP	10K 5% 1/10W
Q805	8-729-038-67	TRANSISTOR	KRC102S	R240	1-216-817-11	METAL CHIP	470 5% 1/10W
Q806	8-729-038-67	TRANSISTOR	KRC102S	R240	1-216-818-11	METAL CHIP	560 5% 1/10W (EXCEPT E, SP, AR)
Q807	8-729-038-67	TRANSISTOR	KRC102S	R241	1-216-833-11	METAL CHIP	10K 5% 1/10W (E, SP, AR)
Q808	8-729-038-67	TRANSISTOR	KRC102S	R242	1-216-839-11	METAL CHIP	33K 5% 1/10W
Q810	8-729-038-67	TRANSISTOR	KRC102S	R243	1-216-845-11	METAL CHIP	100K 5% 1/10W
Q811	8-729-038-67	TRANSISTOR	KRC102S	R245	1-249-389-11	CARBON	4.7 5% 1/4W
Q812	8-729-901-81	TRANSISTOR	2SC2412K-T-146-R (AEP, UK)	R260	1-216-805-11	METAL CHIP	47 5% 1/10W
Q813	8-729-038-67	TRANSISTOR	KRC102S	R301	1-216-797-11	METAL CHIP	10 5% 1/10W
Q814	8-729-038-67	TRANSISTOR	KRC102S	R302	1-216-809-11	METAL CHIP	100 5% 1/10W
Q815	8-729-920-31	TRANSISTOR	DTC343TK-T-146	R303	1-216-809-11	METAL CHIP	100 5% 1/10W
Q816	8-729-920-31	TRANSISTOR	DTC343TK-T-146	R304	1-216-797-11	METAL CHIP	10 5% 1/10W
Q817	8-729-920-31	TRANSISTOR	DTC343TK-T-146	R305	1-216-833-11	METAL CHIP	10K 5% 1/10W
Q818	8-729-920-31	TRANSISTOR	DTC343TK-T-146	R306	1-216-833-11	METAL CHIP	10K 5% 1/10W
Q890	8-729-038-54	TRANSISTOR	KRA102S	R307	1-216-833-11	METAL CHIP	10K 5% 1/10W
Q891	8-729-120-28	TRANSISTOR	2SC2412K-T-146-R	R308	1-216-829-11	METAL CHIP	4.7K 5% 1/10W
		< RESISTOR >		R309	1-216-797-11	METAL CHIP	10 5% 1/10W
R101	1-216-829-11	METAL CHIP	4.7K 5% 1/10W	R310	1-216-809-11	METAL CHIP	100 5% 1/10W
R102	1-216-821-11	METAL CHIP	1K 5% 1/10W	R311	1-216-809-11	METAL CHIP	100 5% 1/10W
R103	1-216-833-11	METAL CHIP	10K 5% 1/10W	R312	1-249-413-11	CARBON	470 5% 1/4W
R104	1-216-825-11	METAL CHIP	2.2K 5% 1/10W	R313	1-249-413-11	CARBON	470 5% 1/4W
R105	1-216-825-11	METAL CHIP	2.2K 5% 1/10W	R314	1-249-413-11	CARBON	470 5% 1/4W
R106	1-216-827-11	METAL CHIP	3.3K 5% 1/10W	R317	1-216-841-11	METAL CHIP	47K 5% 1/10W
R107	1-218-867-11	RES-CHIP	6.8K 5% 1/10W	R318	1-216-841-11	METAL CHIP	47K 5% 1/10W
R113	1-216-829-11	METAL CHIP	4.7K 5% 1/10W	R320	1-216-851-11	METAL CHIP	330K 5% 1/10W
R114	1-216-841-11	METAL CHIP	47K 5% 1/10W	R340	1-247-807-31	CARBON	100 5% 1/4W
R118	1-216-821-11	METAL CHIP	1K 5% 1/10W	R350	1-216-829-11	METAL CHIP	4.7K 5% 1/10W
R120	1-216-829-11	METAL CHIP	4.7K 5% 1/10W	R396	1-216-837-11	METAL CHIP	22K 5% 1/10W
R121	1-216-849-11	METAL CHIP	220K 5% 1/10W	R397	1-216-797-11	METAL CHIP	10 5% 1/10W
R122	1-216-829-11	METAL CHIP	4.7K 5% 1/10W	R501	1-216-843-11	METAL CHIP	68K 5% 1/10W
R123	1-216-837-11	METAL CHIP	22K 5% 1/10W	R502	1-216-841-11	METAL CHIP	47K 5% 1/10W
R132	1-216-833-11	METAL CHIP	10K 5% 1/10W	R503	1-216-841-11	METAL CHIP	47K 5% 1/10W
R140	1-216-817-11	METAL CHIP	470 5% 1/10W (EXCEPT E, SP, AR)	R504	1-216-821-11	METAL CHIP	1K 5% 1/10W
R140	1-216-818-11	METAL CHIP	560 5% 1/10W (E, SP, AR)	R505	1-216-833-11	METAL CHIP	10K 5% 1/10W
R141	1-216-833-11	METAL CHIP	10K 5% 1/10W	R601	1-216-829-11	METAL CHIP	4.7K 5% 1/10W
R142	1-216-839-11	METAL CHIP	33K 5% 1/10W	R602	1-216-825-11	METAL CHIP	2.2K 5% 1/10W
R143	1-216-845-11	METAL CHIP	100K 5% 1/10W	R603	1-216-829-11	METAL CHIP	4.7K 5% 1/10W
R144	1-249-389-11	CARBON	4.7 5% 1/4W	R604	1-216-829-11	METAL CHIP	4.7K 5% 1/10W
				R605	1-249-407-11	CARBON	150 5% 1/4W
				R606	1-216-841-11	METAL CHIP	47K 5% 1/10W
				R607	1-216-841-11	METAL CHIP	47K 5% 1/10W

Ref. No.	Part No.	Description			Remark	Ref. No.	Part No.	Description			Remark
R608	1-216-829-11	METAL CHIP	4.7K	5%	1/10W	R834	1-216-821-11	METAL CHIP	1K	5%	1/10W
R609	1-249-408-11	CARBON	180	5%	1/4W	R835	1-216-821-11	METAL CHIP	1K	5%	1/10W
R610	1-216-843-11	METAL CHIP	68K	5%	1/10W	R836	1-216-821-11	METAL CHIP	1K	5%	1/10W
R611	1-216-845-11	METAL CHIP	100K	5%	1/10W	R837	1-216-821-11	METAL CHIP	1K	5%	1/10W
R612	1-216-821-11	METAL CHIP	1K	5%	1/10W	R838	1-216-817-11	METAL CHIP	470	5%	1/10W
R613	1-216-821-11	METAL CHIP	1K	5%	1/10W	R840	1-216-841-11	METAL CHIP	47K	5%	1/10W
R614	1-216-821-11	METAL CHIP	1K	5%	1/10W	R841	1-216-825-11	METAL CHIP	2.2K	5%	1/10W
R615	1-216-821-11	METAL CHIP	1K	5%	1/10W						(AEP, UK)
R616	1-216-821-11	METAL CHIP	1K	5%	1/10W	R841	1-216-837-11	METAL CHIP	22K	5%	1/10W
R617	1-216-829-11	METAL CHIP	4.7K	5%	1/10W						(E, MX, AR)
R618	1-216-853-11	METAL CHIP	470K	5%	1/10W	R841	1-216-839-11	METAL CHIP	33K	5%	1/10W
R619	1-216-845-11	METAL CHIP	100K	5%	1/10W						(SP, KR, AUS)
R620	1-216-821-11	METAL CHIP	1K	5%	1/10W	R841	1-216-864-11	METAL CHIP	0	5%	1/10W
R621	1-216-814-11	METAL CHIP	270	5%	1/10W						(US, CND)
R622	1-216-841-11	METAL CHIP	47K	5%	1/10W	R842	1-216-833-11	METAL CHIP	10K	5%	1/10W
R623	1-216-843-11	METAL CHIP	68K	5%	1/10W						(AEP, UK)
R626	1-216-829-11	METAL CHIP	4.7K	5%	1/10W	R843	1-216-845-11	METAL CHIP	100K	5%	1/10W
R629	1-216-841-11	METAL CHIP	47K	5%	1/10W	R844	1-216-821-11	METAL CHIP	1K	5%	1/10W
R800	1-216-821-11	METAL CHIP	1K	5%	1/10W						(US, CND)
R801	1-216-821-11	METAL CHIP	1K	5%	1/10W	R844	1-216-827-11	METAL CHIP	3.3K	5%	1/10W
R802	1-216-821-11	METAL CHIP	1K	5%	1/10W						(AEP, UK)
R803	1-216-821-11	METAL CHIP	1K	5%	1/10W	R844	1-216-833-11	METAL CHIP	10K	5%	1/10W
R804	1-216-821-11	METAL CHIP	1K	5%	1/10W						(SP, KR, AUS)
R805	1-216-821-11	METAL CHIP	1K	5%	1/10W	R844	1-216-843-11	METAL CHIP	68K	5%	1/10W
R806	1-216-821-11	METAL CHIP	1K	5%	1/10W						(E, MX, AR)
R807	1-216-821-11	METAL CHIP	1K	5%	1/10W	R845	1-216-845-11	METAL CHIP	100K	5%	1/10W
R808	1-216-821-11	METAL CHIP	1K	5%	1/10W	R846	1-216-837-11	METAL CHIP	22K	5%	1/10W
R809	1-216-821-11	METAL CHIP	1K	5%	1/10W	R847	1-216-833-11	METAL CHIP	10K	5%	1/10W
R810	1-216-821-11	METAL CHIP	1K	5%	1/10W	R848	1-216-833-11	METAL CHIP	10K	5%	1/10W
R811	1-216-821-11	METAL CHIP	1K	5%	1/10W	R849	1-216-833-11	METAL CHIP	10K	5%	1/10W
R812	1-216-821-11	METAL CHIP	1K	5%	1/10W	R850	1-216-829-11	METAL CHIP	4.7K	5%	1/10W
R813	1-216-821-11	METAL CHIP	1K	5%	1/10W	R851	1-216-829-11	METAL CHIP	4.7K	5%	1/10W
R814	1-216-821-11	METAL CHIP	1K	5%	1/10W	R852	1-216-829-11	METAL CHIP	4.7K	5%	1/10W
R815	1-216-821-11	METAL CHIP	1K	5%	1/10W	R853	1-216-829-11	METAL CHIP	4.7K	5%	1/10W
R816	1-216-821-11	METAL CHIP	1K	5%	1/10W	R854	1-216-829-11	METAL CHIP	4.7K	5%	1/10W
R817	1-216-821-11	METAL CHIP	1K	5%	1/10W	R855	1-216-829-11	METAL CHIP	4.7K	5%	1/10W
R818	1-216-821-11	METAL CHIP	1K	5%	1/10W	R856	1-216-829-11	METAL CHIP	4.7K	5%	1/10W
R819	1-216-821-11	METAL CHIP	1K	5%	1/10W	R857	1-216-829-11	METAL CHIP	4.7K	5%	1/10W
R820	1-216-821-11	METAL CHIP	1K	5%	1/10W	R858	1-216-829-11	METAL CHIP	4.7K	5%	1/10W
R821	1-216-821-11	METAL CHIP	1K	5%	1/10W	R859	1-216-829-11	METAL CHIP	4.7K	5%	1/10W
R822	1-216-821-11	METAL CHIP	1K	5%	1/10W	R860	1-216-829-11	METAL CHIP	4.7K	5%	1/10W
R823	1-216-821-11	METAL CHIP	1K	5%	1/10W	R861	1-216-829-11	METAL CHIP	4.7K	5%	1/10W
R824	1-216-821-11	METAL CHIP	1K	5%	1/10W	R862	1-216-829-11	METAL CHIP	4.7K	5%	1/10W
R825	1-216-809-11	METAL CHIP	100	5%	1/10W	R863	1-216-829-11	METAL CHIP	4.7K	5%	1/10W
R826	1-216-821-11	METAL CHIP	1K	5%	1/10W	R864	1-216-829-11	METAL CHIP	4.7K	5%	1/10W
R827	1-216-821-11	METAL CHIP	1K	5%	1/10W	R865	1-216-829-11	METAL CHIP	4.7K	5%	1/10W
R828	1-216-821-11	METAL CHIP	1K	5%	1/10W	R866	1-216-829-11	METAL CHIP	4.7K	5%	1/10W
R829	1-216-821-11	METAL CHIP	1K	5%	1/10W	R867	1-216-829-11	METAL CHIP	4.7K	5%	1/10W
R830	1-216-821-11	METAL CHIP	1K	5%	1/10W	R868	1-216-829-11	METAL CHIP	4.7K	5%	1/10W
R831	1-216-821-11	METAL CHIP	1K	5%	1/10W	R869	1-216-829-11	METAL CHIP	4.7K	5%	1/10W
R832	1-216-821-11	METAL CHIP	1K	5%	1/10W	R870	1-216-829-11	METAL CHIP	4.7K	5%	1/10W
R833	1-216-821-11	METAL CHIP	1K	5%	1/10W	R871	1-216-829-11	METAL CHIP	4.7K	5%	1/10W
						R872	1-216-829-11	METAL CHIP	4.7K	5%	1/10W
						R873	1-216-829-11	METAL CHIP	4.7K	5%	1/10W
						R874	1-216-829-11	METAL CHIP	4.7K	5%	1/10W
						R875	1-216-829-11	METAL CHIP	4.7K	5%	1/10W
						R876	1-216-829-11	METAL CHIP	4.7K	5%	1/10W
						R877	1-216-829-11	METAL CHIP	4.7K	5%	1/10W
						R878	1-216-829-11	METAL CHIP	4.7K	5%	1/10W
						R879	1-216-829-11	METAL CHIP	4.7K	5%	1/10W

HCD-CP101

Ver 1.2

MAIN

MOTOR

POWER

Ref. No.	Part No.	Description	Remark
R880	1-216-829-11	METAL CHIP 4.7K 5%	1/10W
R881	1-216-829-11	METAL CHIP 4.7K 5%	1/10W
R882	1-216-829-11	METAL CHIP 4.7K 5%	1/10W
R883	1-216-829-11	METAL CHIP 4.7K 5%	1/10W
R884	1-216-829-11	METAL CHIP 4.7K 5%	1/10W
R885	1-216-829-11	METAL CHIP 4.7K 5%	1/10W
R886	1-216-821-11	METAL CHIP 1K 5%	1/10W
R887	1-216-821-11	METAL CHIP 1K 5%	1/10W
R888	1-216-821-11	METAL CHIP 1K 5%	1/10W
R890	1-216-829-11	METAL CHIP 4.7K 5%	1/10W
R891	1-216-822-11	METAL CHIP 1.2K 5%	1/10W
R892	1-216-817-11	METAL CHIP 470 5%	1/10W
R894	1-216-821-11	METAL CHIP 1K 5%	1/10W
R895	1-216-821-11	METAL CHIP 1K 5%	1/10W
R896	1-216-829-11	METAL CHIP 4.7K 5%	1/10W
R897	1-216-821-11	METAL CHIP 1K 5%	1/10W
R898	1-216-821-11	METAL CHIP 1K 5%	1/10W
R899	1-216-821-11	METAL CHIP 1K 5%	1/10W

< TERMINAL BOARD/JACK >

SJ301	1-694-820-11	TERMINAL BOARD (SPEAKER IMPEDANCE USE 6-16Ω)
SJ302	1-815-045-11	JACK, PIN 2P (AUDIO IN MD (VIDEO))

< THERMISTOR >

TH1	1-537-770-21	TERMINAL BOARD, GROUND
TH2	1-537-770-21	TERMINAL BOARD, GROUND

< TUNER PACK >

TU1	A-4303-953-A	TUNER PACK (AEP, UK, KR, AUS)
TU1	A-4303-954-A	TUNER PACK (US, CND, E, SP, MX, AR)

< VIBRATOR >

X801	1-579-901-11	VIBRATOR, CERAMIC (4.19MHz)
X802	1-567-098-41	VIBRATOR, CRYSTAL (32.768kHz)
X803	1-579-242-41	VIBRATOR, CRYSTAL (4.332MHz) (AEP, UK)

1-681-807-11	MOTOR BOARD

*	1-568-943-11	PIN, CONNECTOR 5P
---	--------------	-------------------

< SWITCH >

S1	1-771-799-11	SWITCH, LEVER SLIDE (CD LID OPEN/COLSE DETECT)
----	--------------	---

Ref. No.	Part No.	Description	Remark
	A-4728-261-A	POWER BOARD, COMPLETE (AEP, UK, AUS)	
	A-4729-303-A	POWER BOARD, COMPLETE (E, SP, AR)	
	A-4729-396-A	POWER BOARD, COMPLETE (US, CND)	
	A-4729-399-A	POWER BOARD, COMPLETE (MX)	
	A-4730-026-A	POWER BOARD, COMPLETE (KR)	

	1-533-313-11	HOLDER, FUSE	
	< CAPACITOR >		
△ C901	1-113-925-11	CERAMIC 0.01uF 20%	250V
C910	1-161-494-00	CERAMIC 0.022uF	25V
C911	1-126-947-11	ELECT 47uF 20%	16V
C917	1-126-934-11	ELECT 220uF 20%	10V
C918	1-126-964-11	ELECT 10uF 20%	50V
C919	1-162-964-11	CERAMIC CHIP 0.001uF 10%	50V
C920	1-104-666-11	ELECT 220uF 20%	25V
C921	1-162-974-11	CERAMIC CHIP 0.01uF	50V
C922	1-162-974-11	CERAMIC CHIP 0.01uF	50V

< CONNECTOR >

CN901	1-564-321-00	PIN, CONNECTOR 2P
* CN902	1-766-281-11	PIN, CONNECTOR (PC BOARD) 8P

< DIODE >

D902	8-719-902-17	DIODE 1N5401
D903	8-719-902-17	DIODE 1N5401
D904	8-719-902-17	DIODE 1N5401
D905	8-719-902-17	DIODE 1N5401
D906	8-719-046-07	DIODE 2A02M
D907	8-719-046-07	DIODE 2A02M
D908	8-719-046-07	DIODE 2A02M
D909	8-719-046-07	DIODE 2A02M
D910	8-719-991-33	DIODE 1SS133T-77
D911	8-719-991-33	DIODE 1SS133T-77
D912	8-719-991-33	DIODE 1SS133T-77
D913	8-719-991-33	DIODE 1SS133T-77
D915	8-719-109-97	DIODE MTZJ-T-77-6.8B
D917	8-719-991-33	DIODE 1SS133T-77
D918	8-719-109-93	DIODE MTZJ-T-77-6.2B

< LINE FILTER >

△ LF901	1-424-150-11	TRANSFORMER, LINE FILTER (US, CND)
---------	--------------	------------------------------------

< TRANSISTOR >

Q901	8-729-028-54	TRANSISTOR KTC3205-Y-AT
Q902	8-729-119-79	TRANSISTOR 2SC2785TP-FEK
Q903	8-729-028-54	TRANSISTOR KTC3205-Y-AT

< RESISTOR >

R902	1-249-425-11	CARBON 4.7K 5%	1/4W
R903	1-249-409-11	CARBON 220 5%	1/4W
R904	1-249-425-11	CARBON 4.7K 5%	1/4W
R905	1-249-437-11	CARBON 47K 5%	1/4W
△ R909	1-219-237-11	SOLID 3.3M 20%	1/2W (US, CND)

< RELAY >

△ RY901	1-755-332-11	RELAY
---------	--------------	-------

The components identified by mark △ or dotted line with mark △ are critical for safety. Replace only with part number specified.

Les composants identifiés par une marque △ sont critiques pour la sécurité. Ne les remplacer que par une pièce portant le numéro spécifié.

Ref. No.	Part No.	Description	Remark	Ref. No.	Part No.	Description	Remark
		< SWITCH >				< IC >	
△S901	1-786-152-11	SWITCH, SLIDE (VOLTAGE SELECTOR) (E, SP, AR)		IC401	6-702-130-01	IC HA12237F	
		< TRANSFORMER >				< RESISTOR >	
△T901	1-437-844-11	TRANSFORMER, POWER (E, SP, AR)		JR102	1-216-864-11	METAL CHIP	0 5% 1/10W
△T901	1-437-730-11	TRANSFORMER, POWER (AEP, UK, KR, AUS)		JR103	1-216-864-11	METAL CHIP	0 5% 1/10W
△T901	1-437-731-11	TRANSFORMER, POWER (US, CND, MX)		JR104	1-216-864-11	METAL CHIP	0 5% 1/10W
		*****		JR105	1-216-864-11	METAL CHIP	0 5% 1/10W
		A-4728-263-A TC BOARD, COMPLETE		JR106	1-216-864-11	METAL CHIP	0 5% 1/10W
		*****				< TRANSISTOR >	
		< CAPACITOR >				< RESISTOR >	
C101	1-164-315-11	CERAMIC CHIP	470PF 5% 50V	Q100	8-729-212-02	TRANSISTOR	2SC2120-T
C102	1-126-933-11	ELECT	100uF 20% 16V	Q101	8-729-212-02	TRANSISTOR	2SC2120-T
C104	1-130-483-00	MYLAR	0.01uF 5% 50V	Q200	8-729-212-02	TRANSISTOR	2SC2120-T
C105	1-126-960-11	ELECT	1uF 20% 50V	Q201	8-729-212-02	TRANSISTOR	2SC2120-T
C106	1-126-964-11	ELECT	10uF 20% 50V	Q401	8-729-212-02	TRANSISTOR	2SC2120-T
C107	1-126-960-11	ELECT	1uF 20% 50V	Q402	8-729-037-02	TRANSISTOR	KTA1266Y-AT
C108	1-126-961-11	ELECT	2.2uF 20% 50V	Q403	8-729-038-67	TRANSISTOR	KRC102S
C109	1-162-964-11	CERAMIC CHIP	0.001uF 10% 50V	Q404	8-759-068-54	TRANSISTOR	KRA102S
C110	1-162-970-11	CERAMIC CHIP	0.01uF 10% 25V	Q405	8-729-038-71	TRANSISTOR	KRC107S
C111	1-162-961-11	CERAMIC CHIP	330PF 10% 50V			< RESISTOR >	
C201	1-164-315-11	CERAMIC CHIP	470PF 5% 50V	R101	1-216-841-11	METAL CHIP	47K 5% 1/10W
C202	1-126-933-11	ELECT	100uF 20% 16V	R102	1-216-825-11	METAL CHIP	2.2K 5% 1/10W
C204	1-130-483-00	MYLAR	0.01uF 5% 50V	R103	1-216-833-11	METAL CHIP	10K 5% 1/10W
C205	1-126-960-11	ELECT	1uF 20% 50V	R104	1-216-825-11	METAL CHIP	2.2K 5% 1/10W
C206	1-126-964-11	ELECT	10uF 20% 50V	R105	1-216-841-11	METAL CHIP	47K 5% 1/10W
C207	1-126-960-11	ELECT	1uF 20% 50V	R106	1-216-833-11	METAL CHIP	10K 5% 1/10W
C208	1-126-961-11	ELECT	2.2uF 20% 50V	R107	1-216-833-11	METAL CHIP	10K 5% 1/10W
C209	1-162-964-11	CERAMIC CHIP	0.001uF 10% 50V	R108	1-216-833-11	METAL CHIP	10K 5% 1/10W
C210	1-162-970-11	CERAMIC CHIP	0.01uF 10% 25V	R109	1-216-825-11	METAL CHIP	2.2K 5% 1/10W
C211	1-162-961-11	CERAMIC CHIP	330PF 10% 50V	R111	1-216-833-11	METAL CHIP	10K 5% 1/10W
C400	1-126-964-11	ELECT	10uF 20% 50V	R112	1-216-830-11	METAL CHIP	5.6K 5% 1/10W
C401	1-126-933-11	ELECT	100uF 20% 16V	R113	1-216-797-11	METAL CHIP	10 5% 1/10W
C402	1-162-970-11	CERAMIC CHIP	0.01uF 10% 25V	R201	1-216-841-11	METAL CHIP	47K 5% 1/10W
C403	1-162-970-11	CERAMIC CHIP	0.01uF 10% 25V	R202	1-216-825-11	METAL CHIP	2.2K 5% 1/10W
C407	1-126-965-11	ELECT	22uF 20% 50V	R203	1-216-833-11	METAL CHIP	10K 5% 1/10W
C410	1-126-960-11	ELECT	1uF 20% 50V	R204	1-216-825-11	METAL CHIP	2.2K 5% 1/10W
C422	1-162-969-11	CERAMIC CHIP	0.0068uF 10% 25V	R205	1-216-841-11	METAL CHIP	47K 5% 1/10W
C432	1-136-967-11	MYLAR	0.012uF 5% 50V	R206	1-216-833-11	METAL CHIP	10K 5% 1/10W
C433	1-162-968-11	CERAMIC CHIP	0.0047uF 10% 50V	R207	1-216-833-11	METAL CHIP	10K 5% 1/10W
C434	1-126-947-11	ELECT	47uF 20% 35V	R208	1-216-833-11	METAL CHIP	10K 5% 1/10W
C435	1-162-970-11	CERAMIC CHIP	0.01uF 10% 25V	R209	1-216-825-11	METAL CHIP	2.2K 5% 1/10W
C436	1-126-933-11	ELECT	100uF 20% 16V	R211	1-216-833-11	METAL CHIP	10K 5% 1/10W
C437	1-126-965-11	ELECT	22uF 20% 50V	R212	1-216-830-11	METAL CHIP	5.6K 5% 1/10W
		< CONNECTOR >		R213	1-216-797-11	METAL CHIP	10 5% 1/10W
CN301	1-784-778-11	CONNECTOR, FFC 17P		R400	1-218-446-11	METAL CHIP	1 5% 1/10W
CN302	1-691-040-31	CONNECTOR, FFC 8P		R401	1-216-827-11	METAL CHIP	3.3K 5% 1/10W
		< DIODE >		R402	1-216-803-11	METAL CHIP	33 5% 1/10W
D401	8-719-988-61	DIODE 1SS355TE-17		R403	1-216-805-11	METAL CHIP	47 5% 1/10W
				R404	1-216-833-11	METAL CHIP	10K 5% 1/10W
				R405	1-216-797-11	METAL CHIP	10 5% 1/10W
				R406	1-216-829-11	METAL CHIP	4.7K 5% 1/10W
				R407	1-216-841-11	METAL CHIP	47K 5% 1/10W
				R408	1-216-829-11	METAL CHIP	4.7K 5% 1/10W
				R409	1-216-829-11	METAL CHIP	4.7K 5% 1/10W

The components identified by mark △ or dotted line with mark ▲ are critical for safety. Replace only with part number specified.	Les composants identifiés par une marque △ sont critiques pour la sécurité. Ne les remplacer que par une pièce portant le numéro spécifié.
--	--



Ref. No.	Part No.	Description	Remark
R410	1-216-833-11	METAL CHIP 10K 5%	1/10W
R411	1-216-841-11	METAL CHIP 47K 5%	1/10W
R412	1-216-833-11	METAL CHIP 10K 5%	1/10W
R413	1-216-857-11	METAL CHIP 1M 5%	1/10W
R414	1-216-803-11	METAL CHIP 33 5%	1/10W
R415	1-216-841-11	METAL CHIP 47K 5%	1/10W
R416	1-216-821-11	METAL CHIP 1K 5%	1/10W
R417	1-218-725-11	RES-CHIP 24K 5%	1/10W
R418	1-216-829-11	METAL CHIP 4.7K 5%	1/10W
R422	1-216-833-11	METAL CHIP 10K 5%	1/10W
R423	1-216-837-11	METAL CHIP 22K 5%	1/10W
R424	1-216-841-11	METAL CHIP 47K 5%	1/10W
R425	1-216-829-11	METAL CHIP 4.7K 5%	1/10W
R426	1-216-829-11	METAL CHIP 4.7K 5%	1/10W
R428	1-216-829-11	METAL CHIP 4.7K 5%	1/10W
< VARIABLE RESISTOR >			
RV101	1-225-282-21	RES, ADJ, CARBON 33K	
RV201	1-225-282-21	RES, ADJ, CARBON 33K	
< COIL/TRANSFORMER >			
T101	1-419-080-11	COIL	
T201	1-419-080-11	COIL	
T401	1-433-372-31	TRANSFORMER, BIAS OSCILLATION	
< TERMINAL BOARD >			
TH1	1-537-770-21	TERMINAL BOARD, GROUND	
TH2	1-537-770-21	TERMINAL BOARD, GROUND	
TH3	1-537-770-21	TERMINAL BOARD, GROUND	

MISCELLANEOUS			

4	1-757-808-11	CABLE, FLEXIBLE FLAT (18 CORE)	
5	1-757-807-11	CABLE, FLEXIBLE FLAT (20 CORE)	
12	1-824-335-11	WIRE (FLAT TYPE) (EEC) (8 CORE)	
13	1-773-044-11	WIRE (FLAT TYPE) (17 CORE)	
15	1-796-353-11	DECK, MECHANICAL	
62	1-757-807-11	CABLE, FLEXIBLE FLAT (20 CORE)	
63	1-477-315-11	INDICATOR BLOCK, LED	
101	1-792-411-11	CABLE, FLEXIBLE FLAT (19 CORE)	
△ 105	1-696-169-11	CORD, POWER (AEP, UK, SP)	
△ 105	1-696-848-41	CORD, POWER (AUS)	
△ 105	1-769-079-21	CORD, POWER (KR)	
△ 105	1-775-789-91	CORD, POWER (E, MX)	
△ 105	1-783-532-11	CORD, POWER (US, CND)	
△ 105	1-783-941-21	CORD, POWER (AR)	
513	1-792-411-11	CABLE, FLEXIBLE FLAT (19 CORE)	
△ 553	A-4735-357-A	OP BASE ASSY (KSM-213DHAP/ZRP1)	
555	1-757-055-11	WIRE, PARALLEL (FFC) (16 CORE)	
M901	A-2004-893-A	MOTOR (LD) ASSY (LOADING)	
F901	1-533-464-11	FUSE, GLASS TUBE (DIA. 5) (0.8A/250V)	
		(AEP, UK, KR, AUS)	
F901	1-576-374-11	FUSE, GLASS TUBE (1.25A/125V)	
		(US, CND, MX)	
F902	1-533-466-11	FUSE, GLASS TUBE (DIA. 5) (1.25A/250V)	
		(E, AR, SP)	

Ref. No.	Part No.	Description	Remark
F903	1-533-468-11	FUSE, GLASS TUBE (DIA. 5) (2A/250V)	
		(AEP, UK, E, AR, SP, KR, AUS)	
F903	1-576-375-11	FUSE, GLASS TUBE (3.15A/125V)	
		(US, CND, MX)	
F905	1-533-464-11	FUSE, GLASS TUBE (DIA. 5) (0.8A/250V)	
		(E, AR, SP)	
T902	1-437-248-11	TRANSFORMER, POWER (AEP, UK, KR, AUS)	
T902	1-437-249-11	TRANSFORMER, POWER (US, CND, MX)	
T902	1-437-250-11	TRANSFORMER, POWER (E, AR, SP)	
TU1	A-4303-953-A	TUNER PACK (AEP, UK, KR, AUS)	
TU1	A-4303-954-A	TUNER PACK (US, CND, E, MX, AR, SP)	

ACCESSORIES			

△	1-770-019-51	ADAPTOR, CONVERSION PLUG (UK)	

The components identified by mark △ or dotted line with mark △ are critical for safety. Replace only with part number specified.	Les composants identifiés par une marque △ sont critiques pour la sécurité. Ne les remplacer que par une pièce portant le numéro spécifié.
--	--

MEMO

