

acer

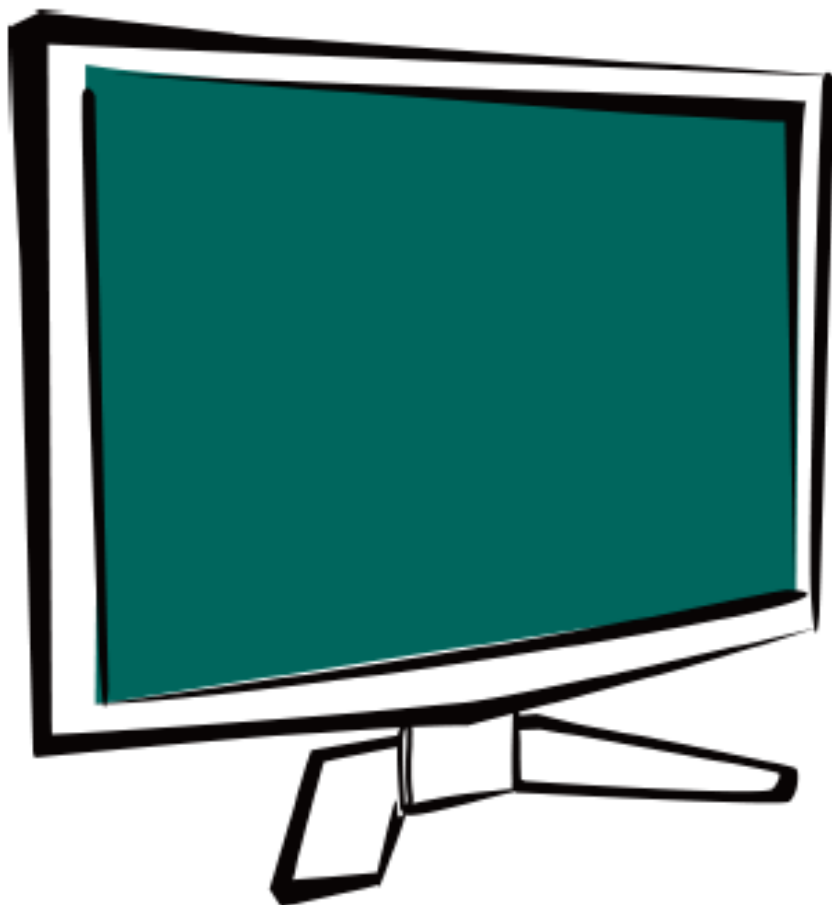

**Acer X203H
Service Guide**

Copyright

Copyright © 2003 by Acer Incorporated. All rights reserved. No part of this publication may be reproduced, Transmitted, transcribed, stored in a retrieval system, or translated into any language or computer language, in any form or by any means, electronic, mechanical, magnetic, optical, chemical, manual or otherwise, without the prior written permission of Acer Incorporated.

Disclaimer

The information in this guide is subject to change without notice. Acer Incorporated makes no representations or warranties, either expressed or implied, with respect to the contents hereof and specifically disclaims any warranties of merchantability or fitness for any particular purpose. Any Acer Incorporated software described in this manual is sold or licensed "as is". Should the programs prove defective following their purchase, the buyer (and not Acer Incorporated, its distributor, or its dealer) assumes the entire cost of all necessary servicing, repair, and any incidental or consequential damages resulting from any defect in the software.

Intel is a registered trademark of Intel Corporation.

Pentium and Pentium II/III are trademarks of Intel Corporation.

Other brand and product names are trademarks and/or registered trademarks of their respective holders.

Trademarks

Acer is a registered trademark of Acer Incorporated.

All other trademarks are property of their respective owners.

Conventions

The following conventions are used in this manual:

Screen messages	Denotes actual messages that appear on screen.
Note	Gives bits and pieces of additional information related to the current topic.
Warning	Alerts you to any damage that might result from doing or not doing specific actions.
Caution	Gives precautionary measures to avoid possible hardware or software problems.
Important	Remind you to do specific actions relevant to the accomplishment of procedures.

Preface

Before using this information and the product it supports, please read the following general information.

1. This Service Guide provides you with all technical information relating to the BASIC CONFIGURATION decided for Acer's "global" product offering. To better fit local market requirements and enhance product competitiveness, your regional office may have decided to extend the functionality of a machine (e.g. add-on card, modem, or extra memory capability). These LOCALIZED FEATURES will NOT be covered in this generic service guide. In such cases, please contact your regional offices or the responsible personnel/channel to provide you with further technical details.
2. Please note WHEN ORDERING FRU PARTS, that you should check the most up-to-date information available on your regional web or channel. If, for whatever reason, a part number change is made, it will not be noted in the printed Service Guide. For ACER-AUTHORIZED SERVICE PROVIDERS, your Acer office may have a DIFFERENT part number code to those given in the FRU list of this printed Service Guide. You MUST use the list provided by your regional Acer office to order FRU parts for repair and service of customer machines.

Warning: (For FCC Certified Models)

Note: This equipment has been tested and found to comply with the limits for a Class B digital device, pursuant to Part 15 of the FCC Rules. These limits are designed to provide reasonable protection against harmful interference in a residential installation. This equipment generates, uses and can radiate radio frequency energy, and if not installed and used in accordance with the instructions, may cause harmful interference to radio communications. However, there is no guarantee that interference will not occur in a particular installation. If this equipment does cause harmful interference to radio or television reception, which can be determined by turning the equipment off and on, the user is encouraged to try to correct the interference by one or more of the following measures:

1. Reorient or relocate the receiving antenna.
2. Increase the separation between the equipment and receiver.
3. Connect the equipment into an outlet on a circuit different from that to which the receiver is connected.
4. Consult the dealer or an experienced radio/TV technician for help.

Notice:

1. The changes or modifications not expressly approved by the party responsible for compliance could void the user's authority to operate the equipment.
2. Shielded interface cables and AC power cord, if any, must be used in order to comply with the emission limits.
3. The manufacturer is not responsible for any radio or TV interference caused by unauthorized modification to this equipment. It is the responsibility of the user to correct such interference.

As ENERGY STAR[®] Partner our company has determined that this product meets the ENERGY STAR[®] guidelines for energy efficiency.

Warning:

To prevent fire or shock hazard, do not expose the monitor to rain or moisture. Dangerous high voltages are present inside the monitor. Do not open the cabinet. Refer servicing to qualified personnel only.

Precautions

- Do not use the monitor near water, e.g. near a bathtub, washbowl, kitchen sink, laundry tub, swimming pool or in a wet basement.
- Do not place the monitor on an unstable trolley, stand, or table. If the monitor falls, it can injure a person and cause serious damage to the appliance. Use only a trolley or stand recommended by the manufacturer or sold with the monitor. If you mount the monitor on a wall or shelf, use a mounting kit approved by the manufacturer and follow the kit instructions.
- Slots and openings in the back and bottom of the cabinet are provided for ventilation. To ensure reliable operation of the monitor and to protect it from overheating, be sure these openings are not blocked or covered. Do not place the monitor on a bed, sofa, rug, or similar surface. Do not place the monitor near or over a radiator or heat register. Do not place the monitor in a bookcase or cabinet unless proper ventilation is provided.
- The monitor should be operated only from the type of power source indicated on the label. If you are not sure of the type of power supplied to your home, consult your dealer or local power company.
- The monitor is equipped with a three-pronged grounded plug, a plug with a third (grounding) pin. This plug will fit only into a grounded power outlet as a safety feature. If your outlet does not accommodate the three-wire plug, have an electrician install the correct outlet, or use an adapter to ground the appliance safely. Do not defeat the safety purpose of the grounded plug.
- Unplug the unit during a lightning storm or when it will not be used for long periods of time. This will protect the monitor from damage due to power surges.
- Do not overload power strips and extension cords. Overloading can result in fire or electric shock.
- Never push any object into the slot on the monitor cabinet. It could short circuit parts causing a fire or electric shock. Never spill liquids on the monitor.
- Do not attempt to service the monitor yourself; opening or removing covers can expose you to dangerous voltages and other hazards. Please refer all servicing to qualified service personnel
- To ensure satisfactory operation, use the monitor only with UL listed computers which have appropriate configured receptacles marked between 100 - 240V AC, Min. 5A.
- The wall socket shall be installed near the equipment and shall be easily accessible.

Special Notes On LCD Monitors

The following symptoms are normal with LCD monitor and do not indicate a problem.

Notes

- Due to the nature of the fluorescent light, the screen may flicker during initial use. Turn off the Power Switch and then turn it on again to make sure the flicker disappears.
- You may find slightly uneven brightness on the screen depending on the desktop pattern you use.
- The LCD screen has effective pixels of 99.99% or more. It may include blemishes of 0.01% or less such as a missing pixel or a pixel lit all of the time.
- Due to the nature of the LCD screen, an afterimage of the previous screen may remain after switching the image, when the same image is displayed for hours. In this case, the screen is recovered slowly by changing the image or turning off the Power Switch for hours.

Table Of Contents

Chapter 1	Monitor Features	7
	Introduction	7
	Electrical Requirements	8
	LCD Monitor General Specification	9
	LCD Panel Specification	10
	Factory Preset Timing	13
	Monitor Block Diagram	14
	Main Board Diagram	15
	Software Flow chart	16
	Main Board Layout	18
	Installation	19
Chapter 2	Operating Instructions	20
	External Controls	20
	Front Panel Controls	20
	eColor Management (OSD)	21
	How to Adjust a Setting	22
	How To Optimize The DOS-Mode	25
	Enter into the factory mode	25
Chapter 3	Machine Disassembly	26
Chapter 4	Troubleshooting	29
Chapter 5	Connector Information	35
Chapter 6	FRU (Field Replacement Unit) List	36
	Exploded Diagram	36
Chapter 7	Schematic Diagram	40

Introduction**Scope**

This specification defines the requirements for the 20.0" MICROPROCESSOR based Multi-mode supported high resolution color LCD monitor. This monitor can be directly connected to general 15-pin D-sub VGA connector, also supports VESA DPMS power management and plug & play function.

Description

The LCD monitor is designed with the latest LCD technology to provide a performance oriented product with no radiation. This will alleviate the growing health concerns. It is also a space saving design, allowing more desktop space, and comparing to the traditional CRT monitor, it consumes less power and gets less weight in addition MTBF target is 50k hours or more.

Chart of X203H

Panel	LTM200KT01 A02(002) SZ SEC
Signal Interface	D-Sub 15pin
Sync Type	Separate / Compatible
Color Temp User Adjust	Support
DDC	DDC2B
Speaker	Yes
Headphone Jack	No
Microphone Jack	No
USB Hub	Not support
Tilt / Swivel	No/No

Electrical Requirements

Standard Test Conditions

All tests shall be performed under the following conditions, unless otherwise specified.

Ambient light	Dark room ($< 1 \text{ cd/m}^2$)
Viewing distance	40 cm for LCD performance, 20 cm for LCD failures
Warm up time	> 30 minutes
Analog Input signal	700 mVss
Control temperature	6500° K
User brightness control	The value under user mode
User contrast control	Set to factory preset value, which allows that the brightest two of 32 linear distributed gray-scales (0~ 700mv) can be distinguished.
Picture position and size	Factory preset value
Viewing angle	90° H and V
AC Supply voltage	220V \pm 5%, 50 \pm 3Hz
Ambient temperature	20+5°C
Humidity	50% \pm 10%
Display mode	1600 x 900, 60 Hz, all white
e-color mode	Set to "User" mode

Measurement systems

The units of measure stated in this document are listed below:

1 gamma = 1 nano tesla

1 tesla = 10,000 gauss

cm = in x 2.54

Lb = kg x 2.2

Degrees F = [°C x 1.8] + 32

Degrees C = [°F - 32]/1.8

$u' = 4x/(-2x + 12y + 3)$

$v' = 9y/(-2x + 12y + 3)$

$x = (27u'/4)/[(9u'/2) - 12v' + 9]$

$y = (3v')/[(9u'/2) - 12v' + 9]$

nits = cd/(m²) = Ft-L x 3.426

lux = foot-candle x 10.76

LCD Monitor General Specification

LCD Panel	Driving system	TFT Color LCD
	Active Display Area	442.8 (W) × 249.075(H)
	Pixel pitch	0.2768(H) × 0.2768(W)
	Contrast Ratio	10000 : 1 Max(ACM)
	Response time	5ms
	Luminance of White	300(Typ.) cd/m ²
Input	Separate Sync.	H/V TTL
	H-Frequency	30kHz – 80kHz
	V-Frequency	56-75Hz
Viewing angle	(H)90 (V) 90(Type)	
Display Colors	16.7M	
Display mode	1600 x 900 @60Hz	
EPA ENERGY STAR®	ON Mode	< 56W
	OFF Mode	< 1W
Contrast control	Set to factory preset value, which allows that the brightest two of 32 linear distributed gray-scales (0~ 700mv) can be distinguished.	
Power Source	100 V ~ 240 V, 50 ± 3Hz, 60 ± 3Hz	
Environmental Considerations	Operating Temp: 0° to 40°C Storage Temp: -20° to 60°C Operating Humidity: 20% to 85%	
Peak surge current	< 55A peak at 240 VAC and cold starting	
Power line surge	No advance effects (no loss of information or defect) with a maximum of 1 half-wave missing per second	

LCD Panel Specification

LTM200KT01 is a color active matrix liquid crystal display (LCD) that uses amorphous silicon TFT(Thin Film Transistor) as switching components. This model is composed of a TFT LCD panel, a driver circuit and a back light unit. The resolution of a 20.0" is 1600 x 900 and this model can display up to 16.7 millions colors.

General Specifications

Items	Specification	Unit	Note
Pixel Pitch	0.2768(H) x 0.2768(W)	mm	
Active Display Area	442.8(W) x 249.075(H)	mm	
Surface Treatment	Haze 25%, Hard-coating(3H)		
Display Colors	16.7M (6bit Hi-FRC)	colors	
Number of Pixels	1600 x 900	pixel	
Pixel Arrangement	RGB vertical stripe		
Display Mode	Normally White		
Power Consumption	(28.4) Watt (Typ.)		
Luminance of White	300(Typ.)	cd/m ²	

Block Diagram

TFT LCD Module

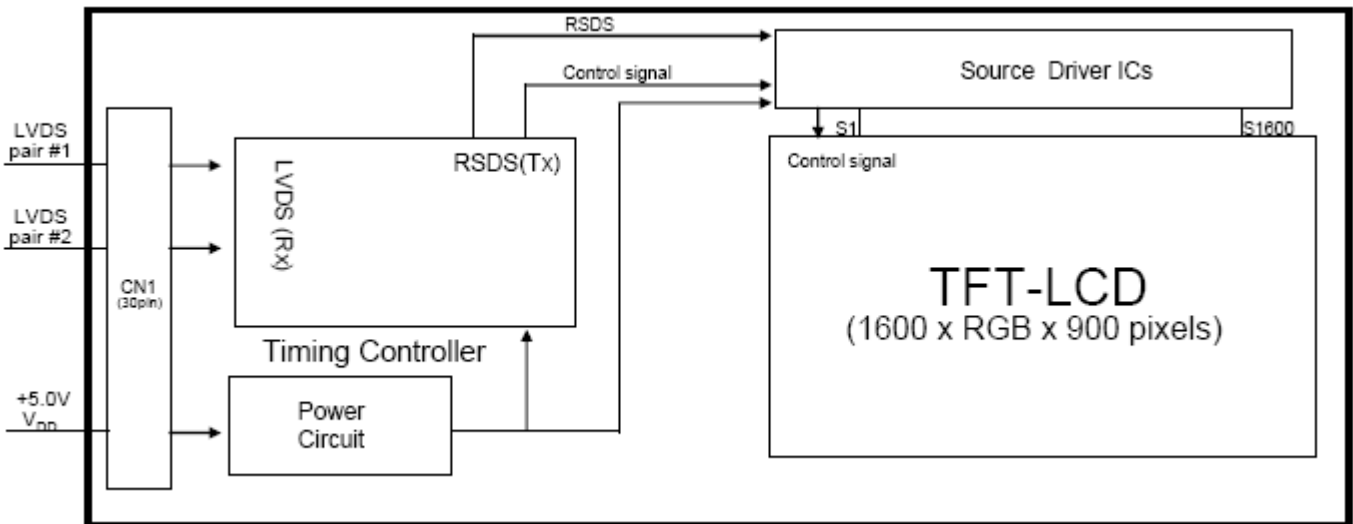

Back light Unit

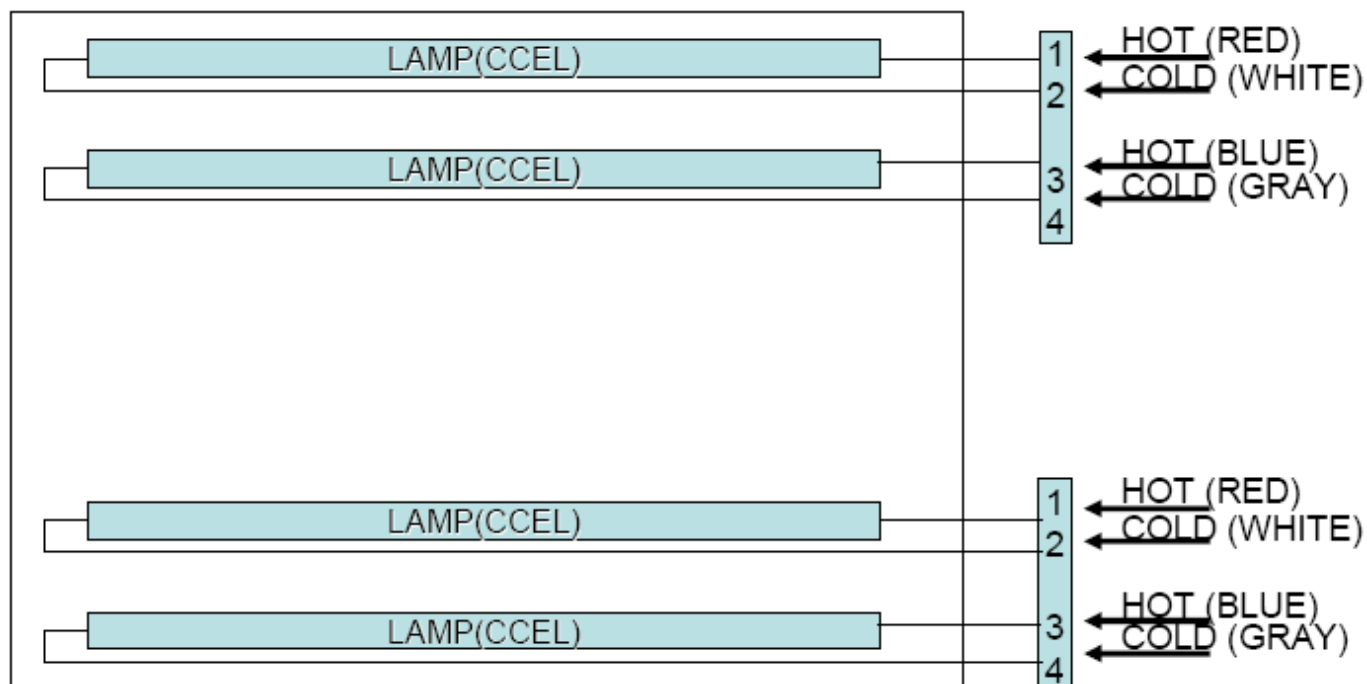

Electrical Characteristics

Item		Symbol	Min.	Typ.	Max.	Unit
Voltage of Power Supply		V_{DD}	4.5	5.0	5.5	V
LVDS Input Characteristics	Differential Input Voltage for LVDS Receiver Threshold	High	-	-	+100	mV
		Low	-100	-	-	mV
	LVDS skew	t_{SKEW}	-300		300	
	Differential input voltage	$ V_{ID} $	200		600	mV
	Input voltage range (single-ended)	V_{IN}	0		2.4	V
	Common mode voltage	V_{CM}	0+ $ V_{ID} /2$	1.2	2.4- $ V_{ID} /2$	V
Current of Power Supply	(a) Black	I_{DD}	-	800	-	mA
	(b) White		-	600	-	mA
	(c) Dot		-	1000	1500	mA
Vsync Frequency		f_V	50	60	75	Hz
Hsync Frequency		f_H	46.3	56.0	70.4	kHz
Main Frequency		f_{DCLK}	48.5	59.2	76.1	MHz
Rush Current		I_{RUSH}	-	-	3.0	A

Optical Specifications

Item		Symbol	Condition	Min.	Typ.	Max.	Unit
Contrast Ratio (Center of screen)		C/R	Normal $\theta_{L,R}=0$ $\theta_{U,D}=0$ Viewing Angle	600	1000	-	
Response Time	On/Off	Tr+Tf		-	5	10	msec
							msec
Luminance of White (Center of screen)		Y_L		250	300	-	cd/m ²
Color Chromaticity (CIE 1931)	Red	R _x		-0.030	+0.030	0.650	
		R _y				0.335	
	Green	G _x				0.295	
		G _y				0.605	
	Blue	B _x				0.145	
		B _y				0.075	
	White	W _x				0.313	
		W _y				0.329	
Color Chromaticity (CIE 1976)	Red	R _{u'}		-	0.455	-	
		R _{v'}	-	0.527	-		
	Green	G _{u'}	-	0.122	-		
		G _{v'}	-	0.563	-		
	Blue	B _{u'}	-	0.161	-		
		B _{v'}	-	0.187	-		
	White	W _{u'}	-	0.198	-		
		W _{v'}	-	0.468	-		
C.G.L	White	$\Delta u'v'$	-	-	0.02		

Item		Symbol	Condition	Min.	Typ.	Max.	Unit
Color Gamut		-		-	72	-	%
Color Temperature		-		-	6500	-	K
Viewing Angle	Hor.	e_L	CR \geq 10	70	80	-	Degrees
		e_R		70	80	-	
	Ver.	e_U		70	80	-	
		e_D		70	80	-	
Brightness Uniformity (9 Points)		B _{uni}		-	-	25	%

Factory Preset Timing

460BVESA MODES							
Mode	Resolution	Total	Horizontal		Vertical		Nominal Pixel Clock (MHz)
			Nominal Frequency +/- 0.5kHz	Sync Polarity	Nominal Freq. +/- 1 Hz	Sync Polarity	
VGA	640x480@60Hz	800 x 525	31.469	N	59.941	N	25.175
	640x480@72Hz	832 x 520	37.861	N	72.809	N	31.500
	640x480@75Hz	840 x 500	37.500	N	75.000	N	31.500
SVGA	800x600@56Hz	1024 x 625	35.156	P	56.250	P	36.000
	800x600@60Hz	1056 x 628	37.879	P	60.317	P	40.000
	800x600@72Hz	1040 x 666	48.077	P	72.188	P	50.000
	800x600@75Hz	1056 x 625	46.875	P	75.000	P	49.500
XGA	1024x768@60Hz	1344 x 806	48.363	N	60.004	N	65.000
	1024x768@70Hz	1328 x 806	56.476	N	70.069	N	75.000
	1024x768@75Hz	1312 x 800	60.023	P	75.029	P	78.750
SXGA	1152x864@75Hz	1600x900	67.5	P	75	P	108.000
	1280x720@60Hz	1650x750	44.955	P	59.940	P	74.176
	1280x960@60Hz	1800x1000	60	P	60	P	108.000
	1280x1024@60Hz	1688x1066	63.981	P	60.020	P	108.000
	1280x1024@75Hz	1688x1066	79.976	P	75.025	P	135.000
WXGA	1360x768@60Hz	1792x795	47.712	N	60.015	N	85.500
WXGA+	1600x900@60Hz	2122x934	55.99	P	59.946	N	118.25
	1600x900@60Hz	1760x926	55.540	P	59.978	N	97.750
461BIBM MODE							
DOS	720x400@70Hz	900 x 449	31.469	N	70.087	P	28.322
462BMAC MODES							
2BVGA	640x480@67Hz	864 x 525	35.000	N	66.667	N	30.240
SVGA	832x624@75Hz	1152 x 667	49.722	N	74.55	N	57.28
SXGA	1152x 870@75Hz	1568x909	68.700		75.000		100.00
ACER SPECIAL MODE							
Acer	1280x800@60Hz	1680x831	49.702	P	59.810	N	83.500

Monitor Block Diagram

The LCD MONITOR will contain a main board, a power board and a key board which house the flat panel control logic, brightness control logic and DDC.

The power board will provide AC to DC Inverter voltage to drive the backlight of panel and the main board chips each voltage.

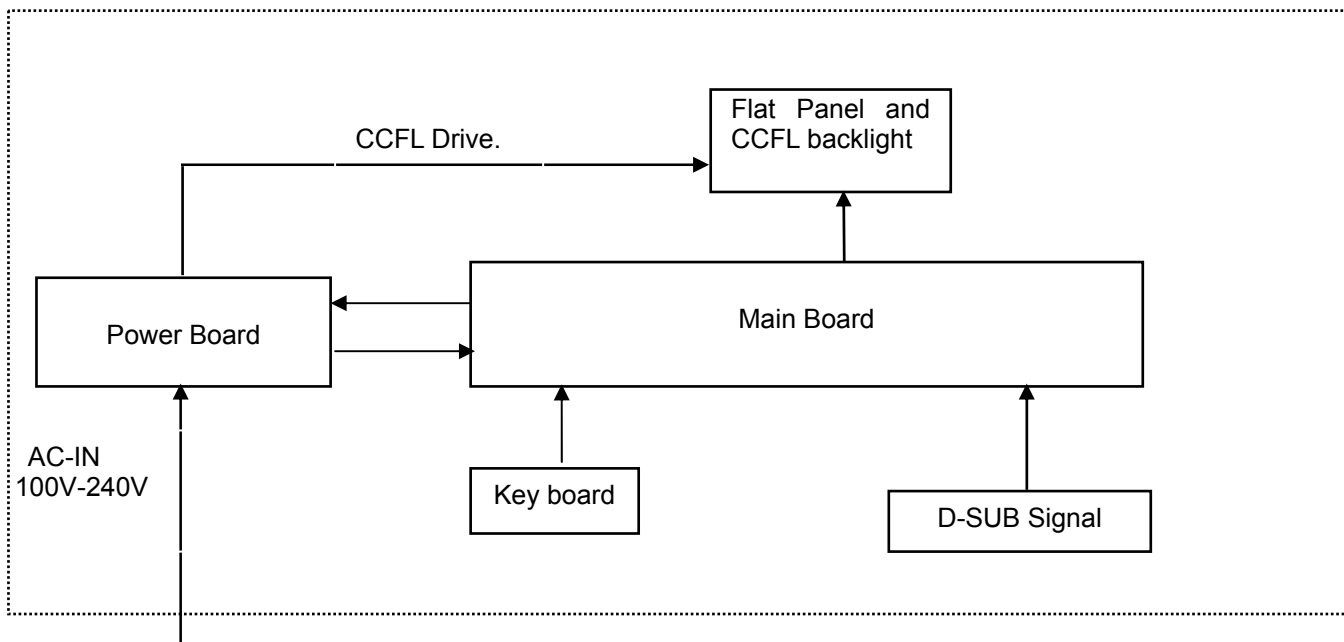

Main Board Diagram

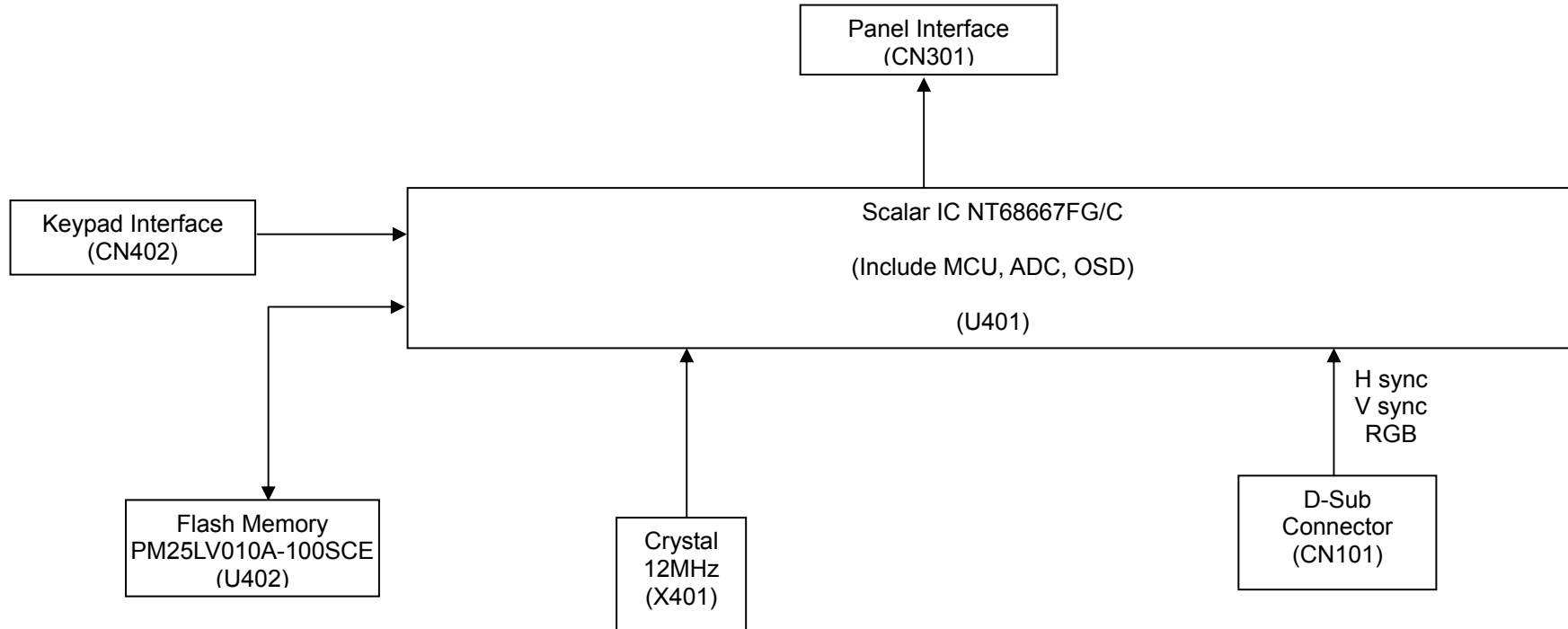

Software Flow Chart

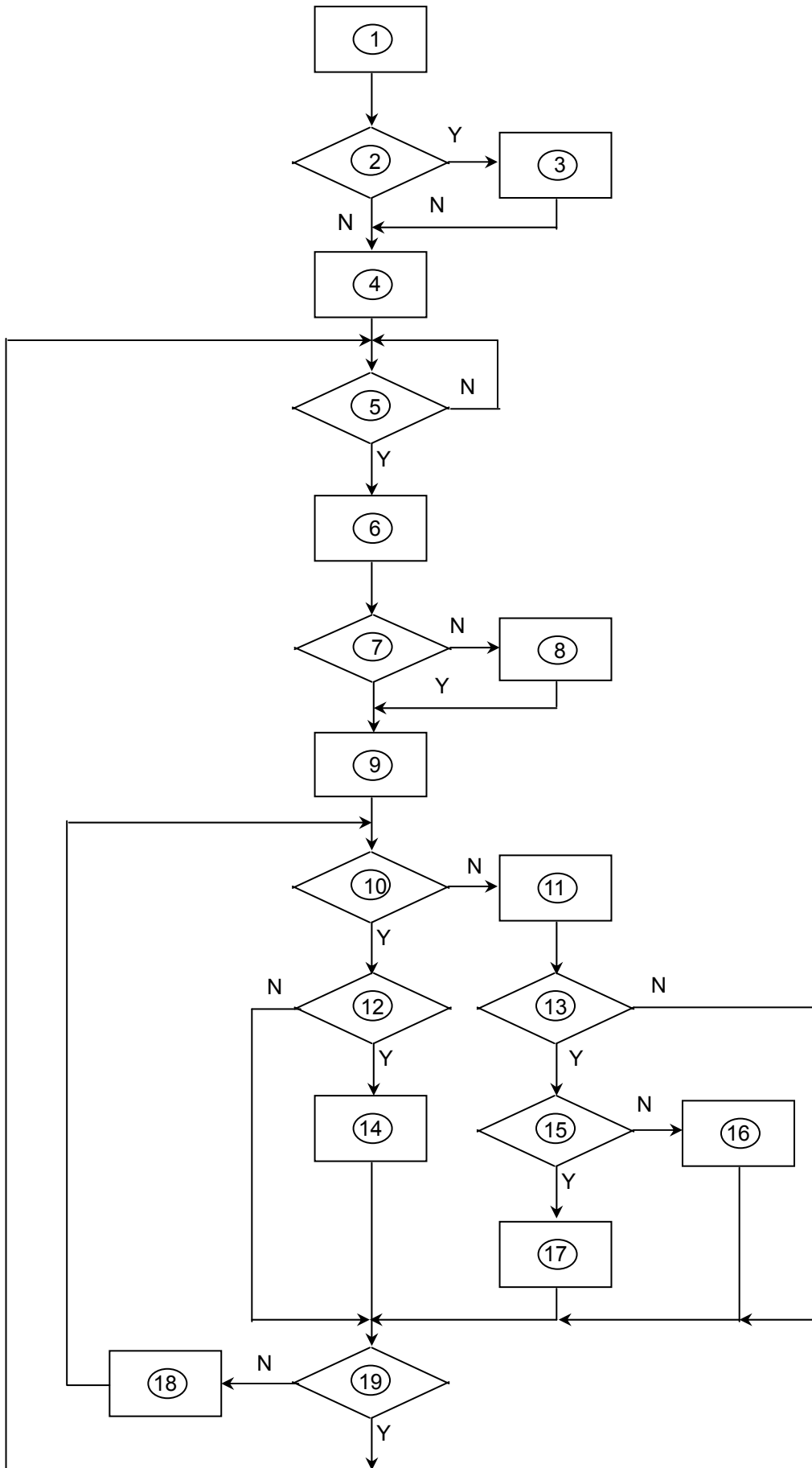

Remark:

1) MCU initializes.
2) Is the EEPROM blank?
3) Program the EEPROM by default values.
4) Get the PWM value of brightness from EEPROM.
5) Is the power key pressed?
6) Clear all global flags.
7) Are the AUTO and SELECT keys pressed?
8) Enter factory mode.
9) Save the power key status into EEPROM. Turn on the LED and set it to green color. Scalar initializes.
10) In standby mode?
11) Update the lifetime of back light.
12) Check the analog port, are there any signals coming?
13) Does the scalar send out an interrupt request?
14) Wake up the scalar.
15) Are there any signals coming from analog port?
16) Display "No connection Check Signal Cable" message. And go into standby mode after the message disappears.
17) Program the scalar to be able to show the coming mode.
18) Process the OSD display.
19) Read the keyboard. Is the power key pressed?

Main Board Layout

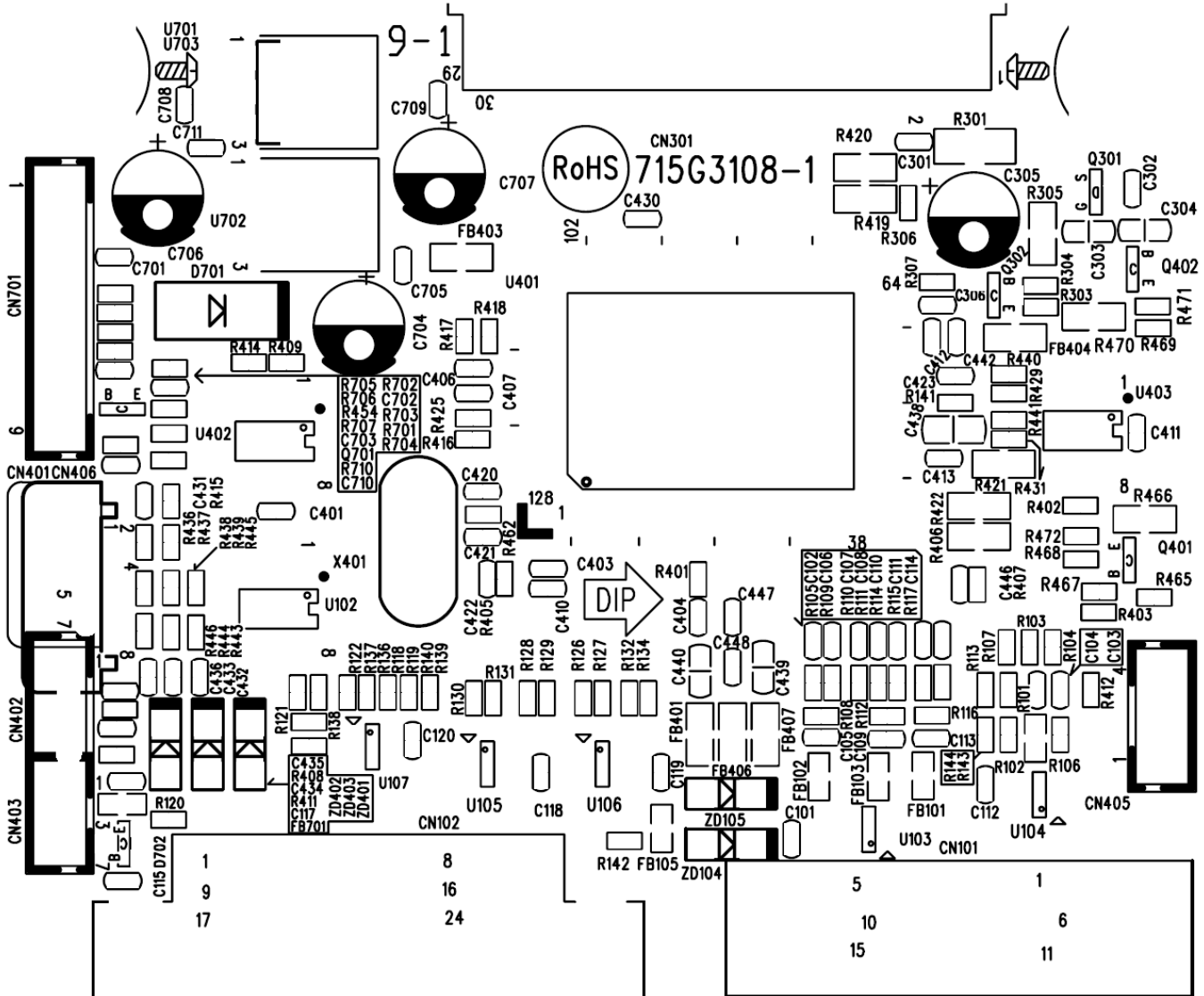

Symbol	Description	Symbol	Description
U401	IC NT68667FG/C QFP-128L	CN402	WAFER
U703	IC AP1117D33L-13 TO252-3L DIODES	CN701	WAFER 9P RIGHT ANELE PITCH
U103	IC AZC099-04S SOT23-6L	CN301	CONNECTOR
U104	IC AZC099-04S SOT23-6L	X401	CRYSTAL 12MHz HC-49US ARG6-120
U402	IC PM25LV010A-100SCE SOIC-8	CN101	D-SUB 15PIN VERTICAL CONN WITH SCREW

Installation

To install the monitor on your host system, please follow the steps below:

Steps

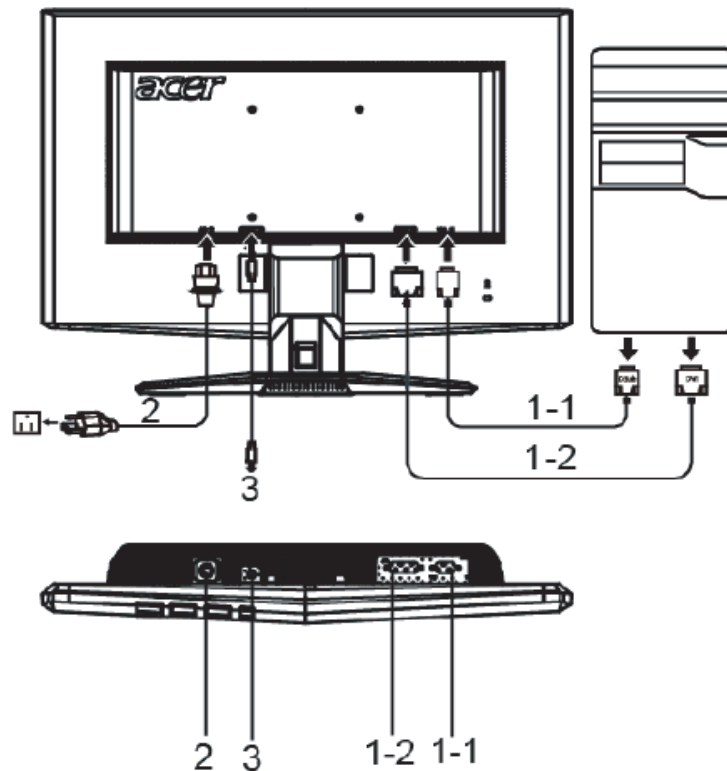

1. Connect Video Cable

- Make sure both the monitor and computer are powered-OFF.
- Connect the video cable to the computer.
- (only Dual-Input Model) Connect one end of the 24-pin DVI cable to the back of the monitor and connect the other end to the computer's port.

2. Connect power cord

Connect the power cord to the monitor, then to a properly grounded AC outlet.

3. Connect the Audio Cable.(optional)

4. Power-ON Monitor and Computer

Power-ON the monitor first, then power-ON the computer.

This sequence is very important.

- If the monitor still does not function properly, please refer to the troubleshooting section to diagnose the problem.

Press the power button to turn the monitor on or off. The other control buttons are located at front panel of the monitor. By changing these settings, the picture can be adjusted to your personal preferences.

- The power cord should be connected.
- Connect the video cable from the monitor to the video card.
- Press the power button to turn on the monitor position. The power indicator will light up.

External Controls

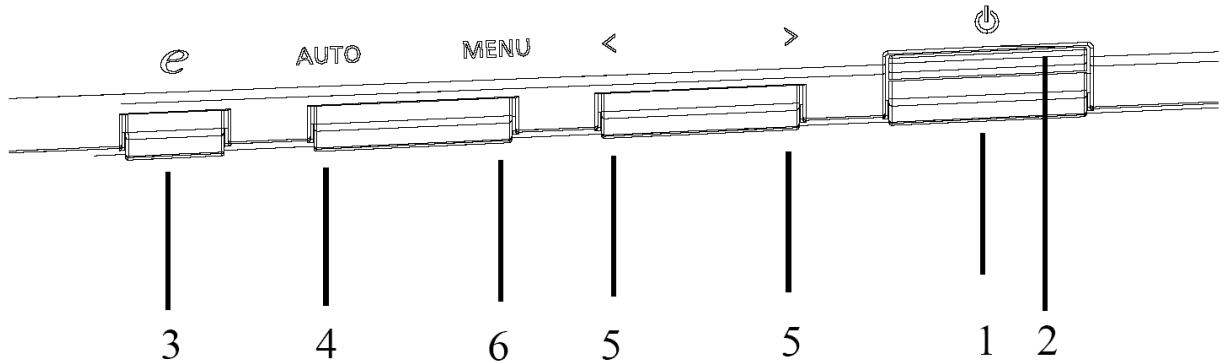

Front panel controls

1. Power Switch:

To turn ON or OFF the power.

2. Power LED:

Lights up to indicate the power is turned ON.

3. Empowering / Exit:

1) When OSD menu is in active status, this button will act as EXIT-KEY(EXIT OSD menu).

2) When OSD menu is in off status, press this button to select scenario mode.

4. Auto Adjust button / Exit:

1) When OSD menu is in active status, this button will act as EXIT-KEY (EXIT OSD menu).

2) When OSD menu is in off status, press this button for 2 seconds to activate the Auto Adjustment function. The Auto Adjustment function is used to set the HPos, VPos, Clock and Focus.

5. < / >

1) Press < or > to select the desired function. Press < or > to change the settings of the current function.

2) Press < or > to adjust the volume up or down (Only for Audio).

6. MENU / ENTER:

Activate OSD menu when OSD is OFF or activate/de-activate adjustment function when OSD is ON.

eColor Management (OSD)





Operation instructions

Step 1: Press “ Key” to open the Acer e-Color Management OSD and access the scenario modes

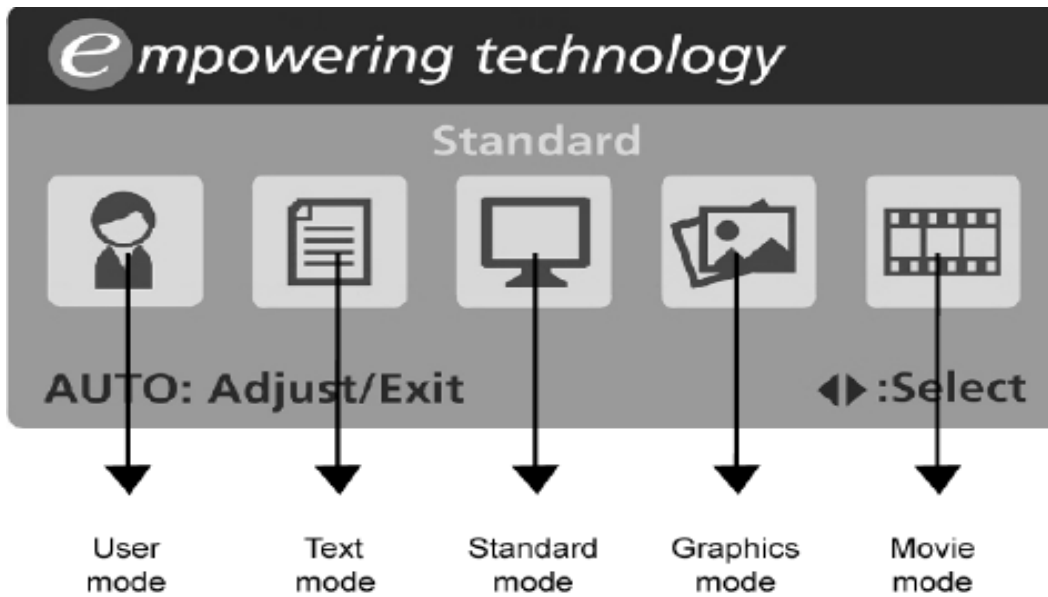
Step 2: Press “<” or “>” to select the mode

Step 3: Press “Auto Key” to confirm the mode and run Auto Adjust



Main Menu icon	Sub Menu icon	Sub Menu item	Description
	N/A	User mode	User defined. Settings can be fine-tuned to suit any situation
	N/A	Text mode	Optimal balance of brightness and contrast prevent eyestrain. The most comfortable way to read onscreen text
	N/A	Standard mode	Default Setting. Reflects native display capability
	N/A	Grahpic mode	Enhances colors and emphasize fine detail
	N/A	Movie mode	Displays scenes in clearest detail. Pictures and photographs appear in vibrant colors with sharp detail)

How to Adjust a Setting

1. Press the MENU-button to activate the OSD window.
 2. Press < or > to select the desired function.
 3. Press the MENU-button to select the function that you want to adjust.
 4. Press < or > to change the settings of the current function.
 5. To exit and save, select the exit function. If you want to adjust any other function, repeat steps 2-4.
- P/X Series OSD behave
When user press "MENU" button on front bezel

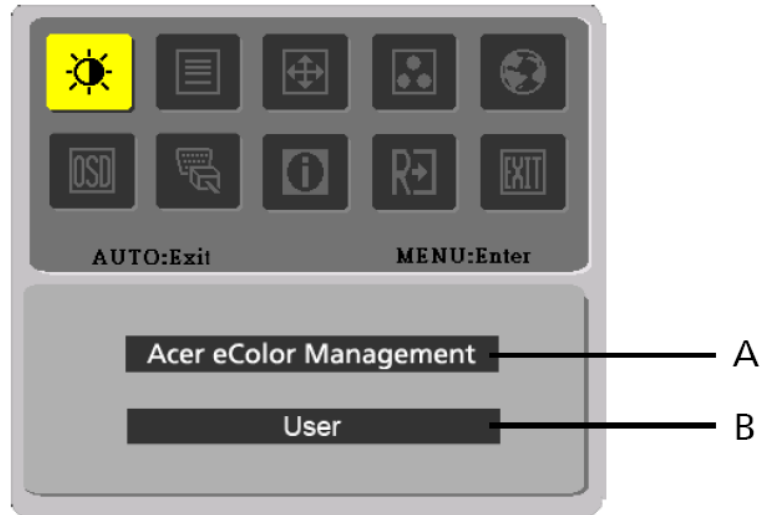

- A. Acer eColor Management
If selected to "Acer eColor Management" item, will appear the Acer eColor" OSD
- B. USER
If selected to "USER" item, will appear the Standard OSD

























I. Only Analog Input Model



II. Only Dual Input Model

Adjusting the picture

Main Menu icon	Sub Menu icon	Sub Menu item	Description
		Contrast	Adjust the contrast between the foreground and background of the screen image
		Brightness	Adjust the background brightness of the screen image
		ACM	ACM (Adaptive Contrast Management) ACM ON/OFF Switch, default "OFF"
		Focus	Adjust picture Focus (available in analog mode only)
		Clock	Adjust picture Clock (available in analog mode only)
		H. Position	Adjust the horizontal position. (available in Analog mode only)
		V. Position	Adjust the vertical position. (available in Analog mode only)
	N/A	Warm	Set the color temperature to warm white.
	N/A	Cool	Set the color temperature to cool white.
		User /Red	Adjusts Red/Green/Blue intensity.
		User /Green	
		User /Blue	

	N/A	English	Multi-language selection.
	N/A	Deutsch	
	N/A	Français	
	N/A	Español	
	N/A	Italiano	
	N/A	繁體中文	Asia version OSD only
	N/A	简体中文	
	N/A	日本語	
	N/A	Suomalainen	EMEA version OSD only
	N/A	Hollands	
N/A	Русский	EMEA & Russian version OSD only	
		H. Position	Adjust the horizontal position of the OSD.
		V. Position	Adjust the vertical position of the OSD.
		OSD Timeout	Adjust the OSD timeout.
	N/A	Analog	Select input signal from analog (D-Sub)
	N/A	Digital (only Dual-Input Model)	Select input signal from digital(DVI) (only Dual-Input Model)
	N/A	DDC/CI	Turn ON/OFF DDC/CI support
	N/A	Information	Show the resolution, H/V frequency and input port of current input timing.
	N/A	Reset	Clear each old status of Auto-configuration and set the color temperature to Warm
	N/A	Exit	Save user adjustment and OSD disappear.

How To Optimize The DOS-Mode

Plug And Play

Plug & Play DDC2B Feature

This monitor is equipped with VESA DDC2B capabilities according to the VESA DDC STANDARD. It allows the monitor to inform the host system of its identity and, depending on the level of DDC used, communicate additional information about its display capabilities.

The DDC2B is a bi-directional data channel based on the I²C protocol. The host can request EDID information over the DDC2B channel.

This monitor will appear to be non-functional if there is no video input signal. In order for this monitor to operate properly, there must be a video input signal.

This monitor meets the Green monitor standards as set by the Video Electronics Standards Association (VESA) and/or the United States Environmental Protection Agency (EPA) and The Swedish Confederation Employees (NUTEK). This feature is designed to conserve electrical energy by reducing power consumption when there is no video-input signal present. When there is no video input signals this monitor, following a time-out period, will automatically switch to an OFF mode. This reduces the monitor's internal power supply consumption. After the video input signal is restored, full power is restored and the display is automatically redrawn. The appearance is similar to a "Screen Saver" feature except the display is completely off. Pressing a key on the keyboard, or clicking the mouse restores the display.

Using the Right Power Cord

The accessory power cord for the Northern American region is the wallet plug with NEMA 5-15 style and is UL listed and CSA labeled. The voltage rating for the power cord shall be 125 volts AC.

Supplied with units intended for connection to power outlet of personal computer: Please use a cord set consisting of a minimum No. 18 AWG, type SJT or SVT three conductors flexible cord. One end terminates with a grounding type attachment plug, rated 10A, 250V, and CEE-22 male configuration. The other end terminates with a molded-on type connector body, rated 10A, 250V, having standard CEE-22 female configuration.

Please note that power supply cord needs to use VDE 0602, 0625, 0821 approval power cord in European countries.

Enter into the factory mode:

Turn off the power, press the "e-color" and turn the power on. The factory OSD will be at the left top of the panel.

This chapter contains step-by-step procedures on how to disassemble the monitor for maintenance.

The tool for disassembly is as follows:

Screwdriver, hexagonal screwdriver, Putty knife.

Disassembly Procedure

1. Remove the hinge assembly.



2. Remove the rear cover and bezel.

The arrows in blue are the hook that we should put attention to when remove the rear cover. Use plastic putty knife to release hooks, then you can easily remove the rear cover.



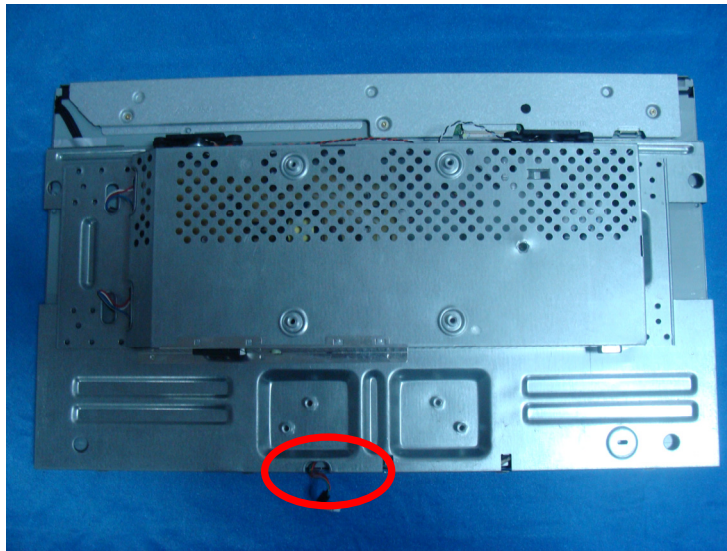

3. Remove the lamp connectors and remove the screws to remove the panel. Put attention to the LVDS cable.

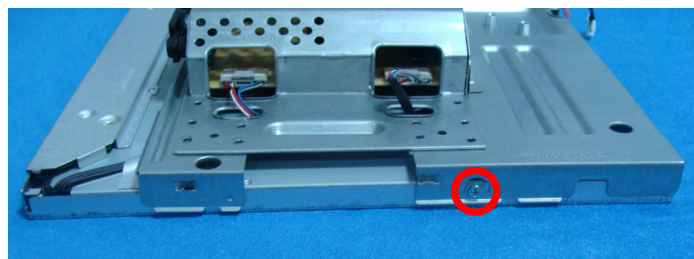
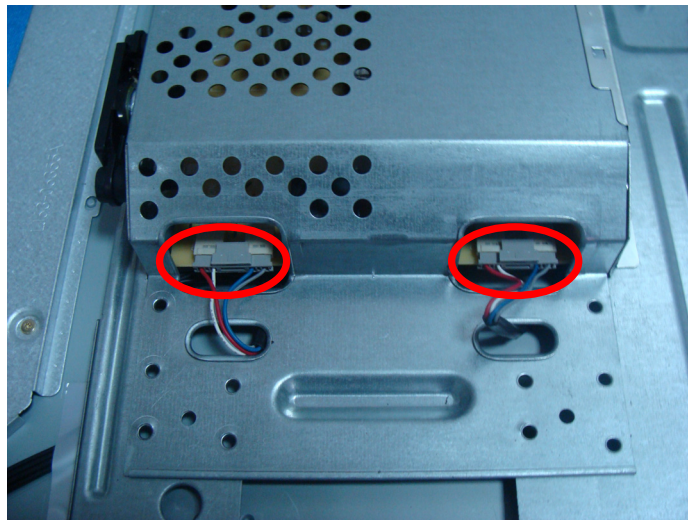

4. Remove the screws to remove the main board and power board.

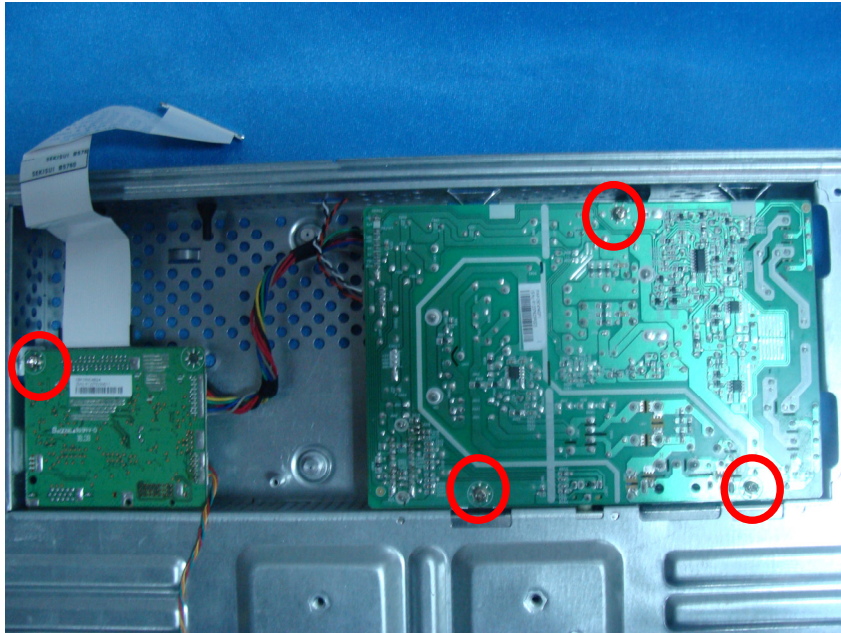

5. The panel



Troubleshooting

This chapter provides troubleshooting information for the X203H:

1. No Power

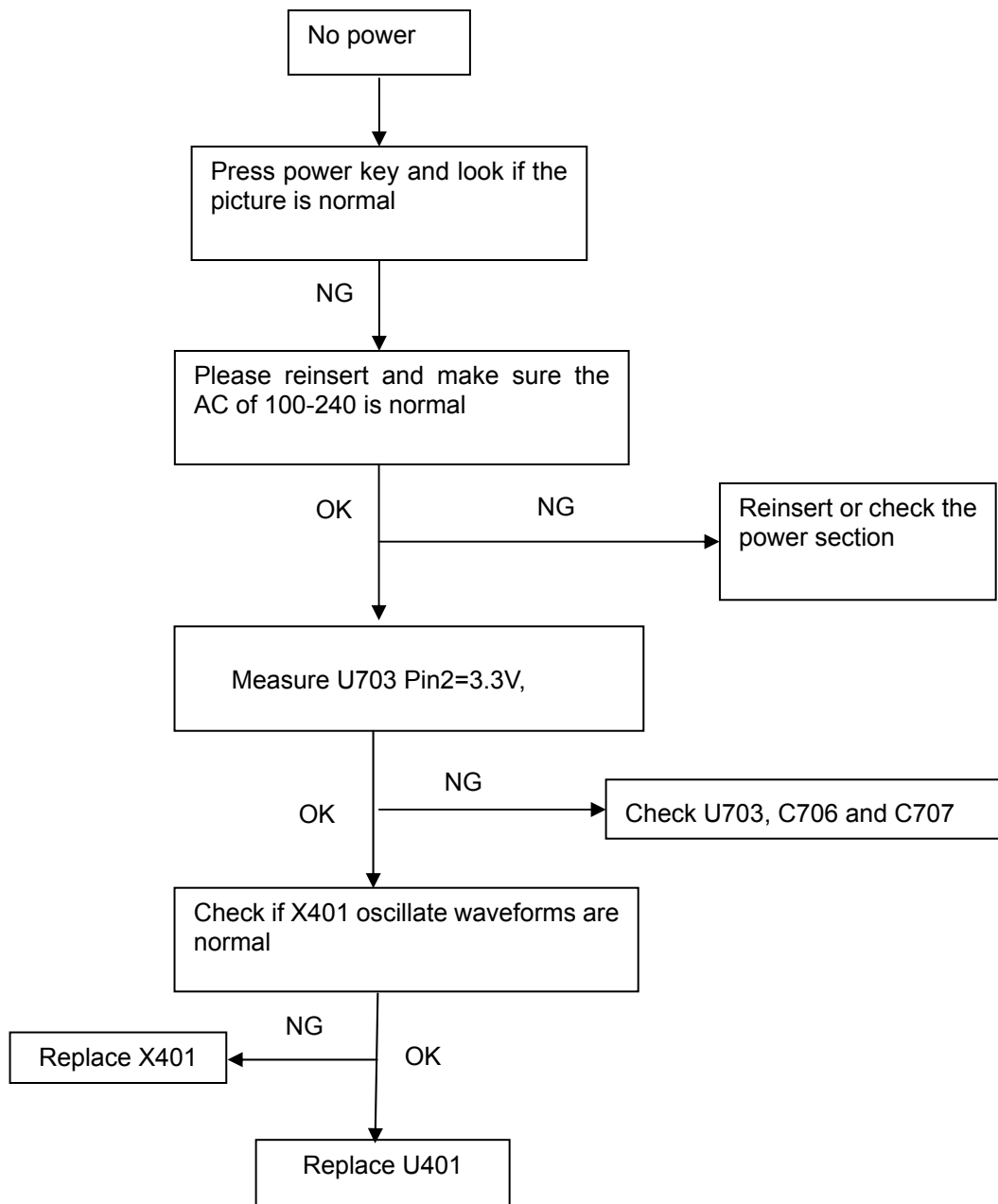

2. No Picture (LED is orange)

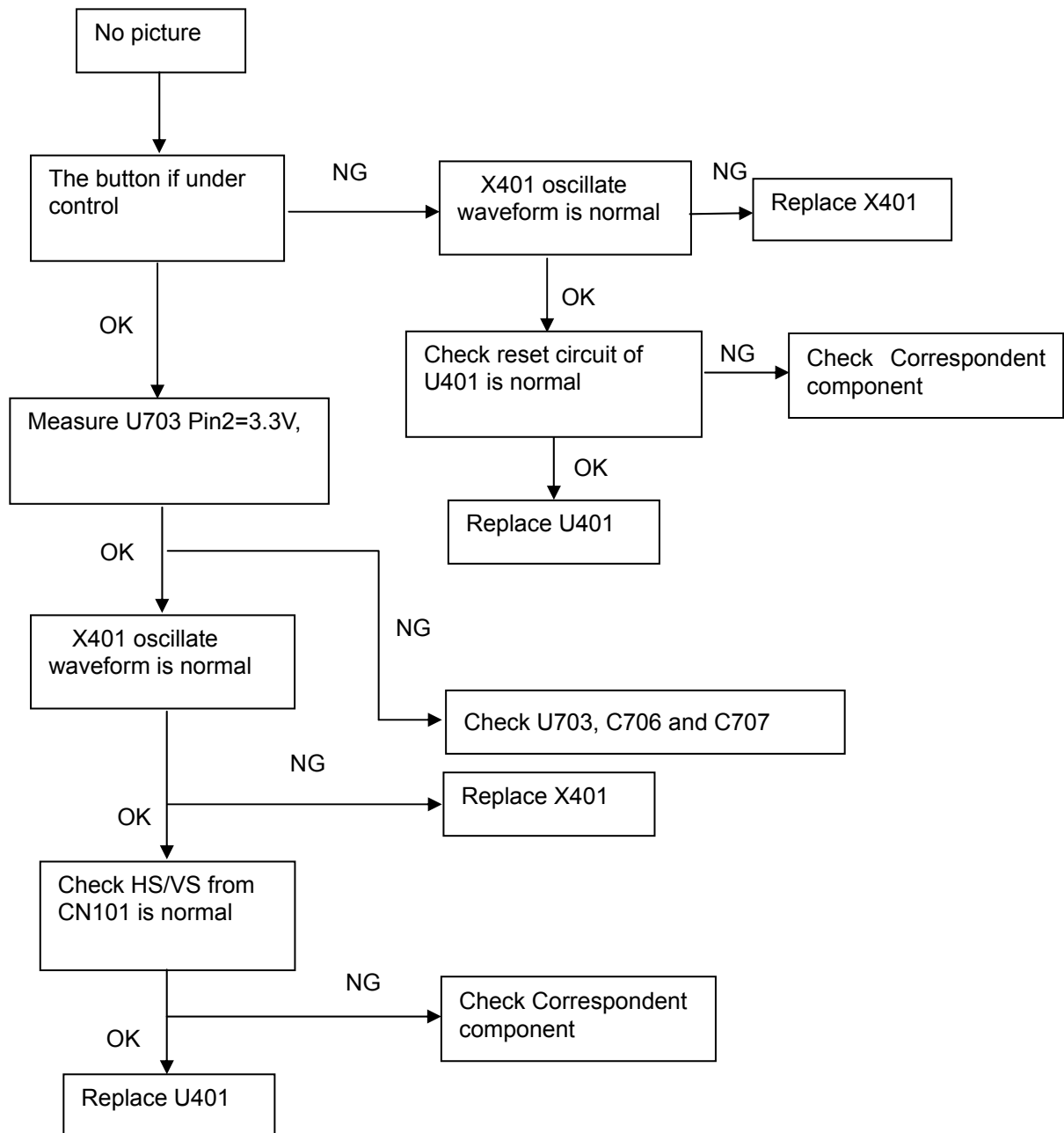

3. Panel Power Circuit

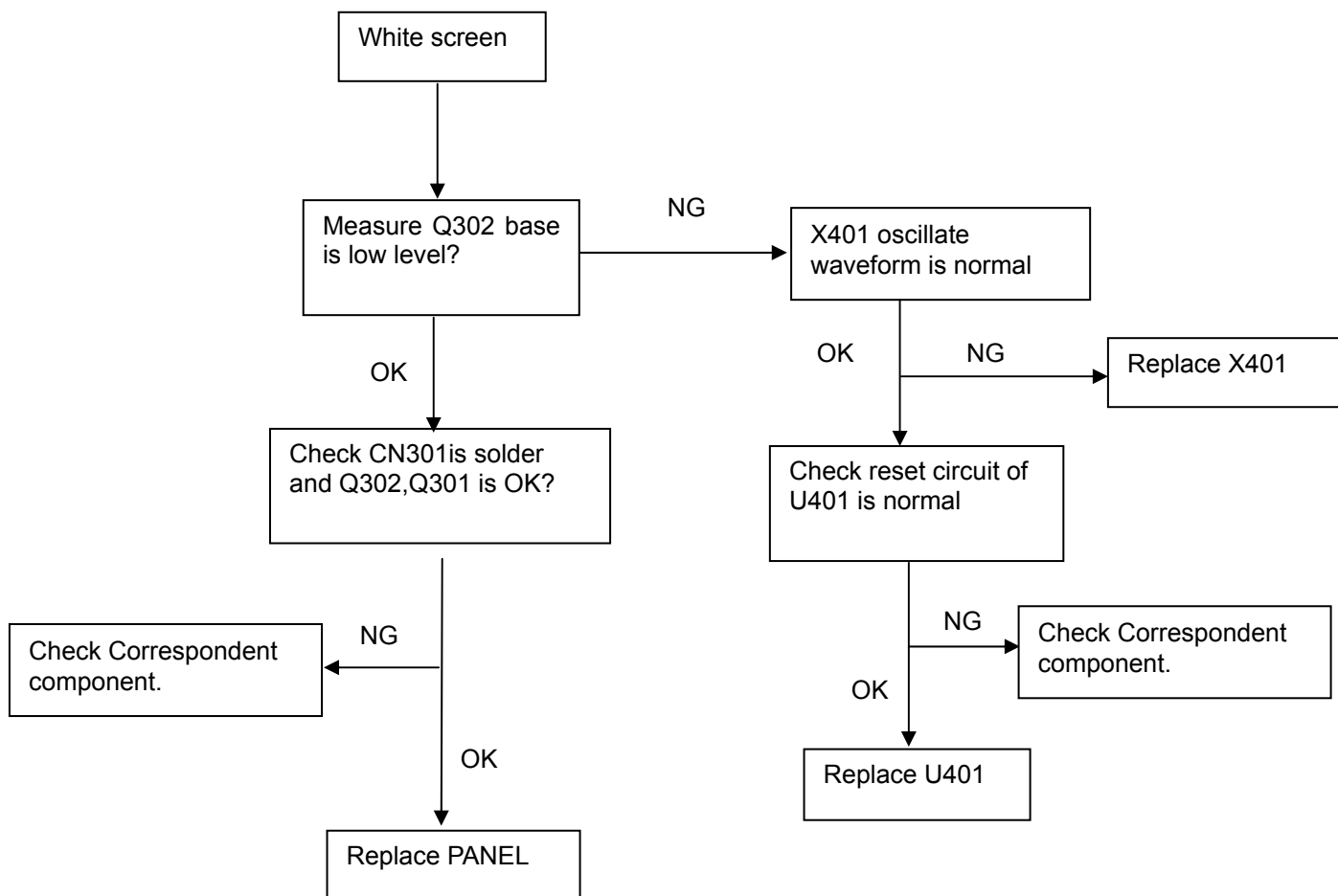

4. Key Board

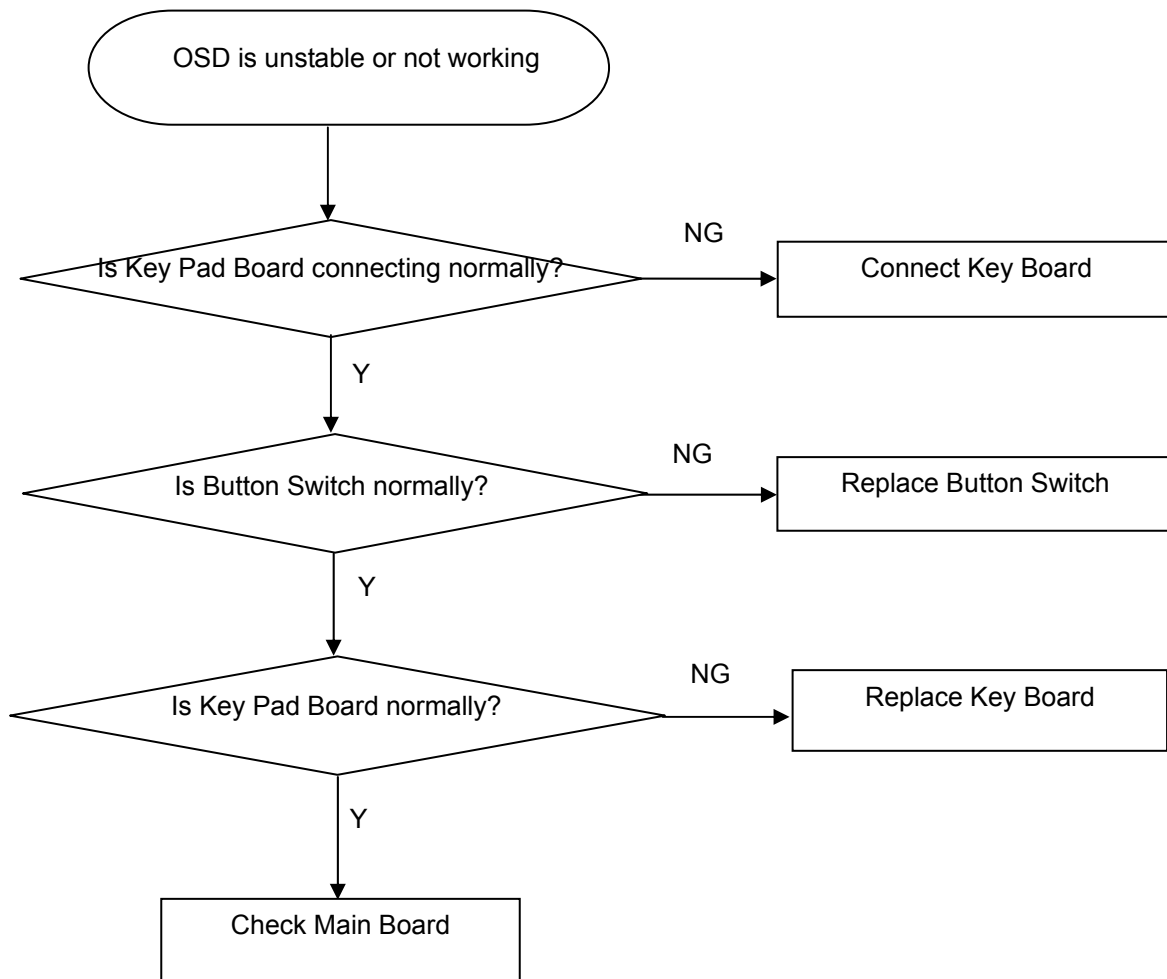

5. Power Board

1) No power

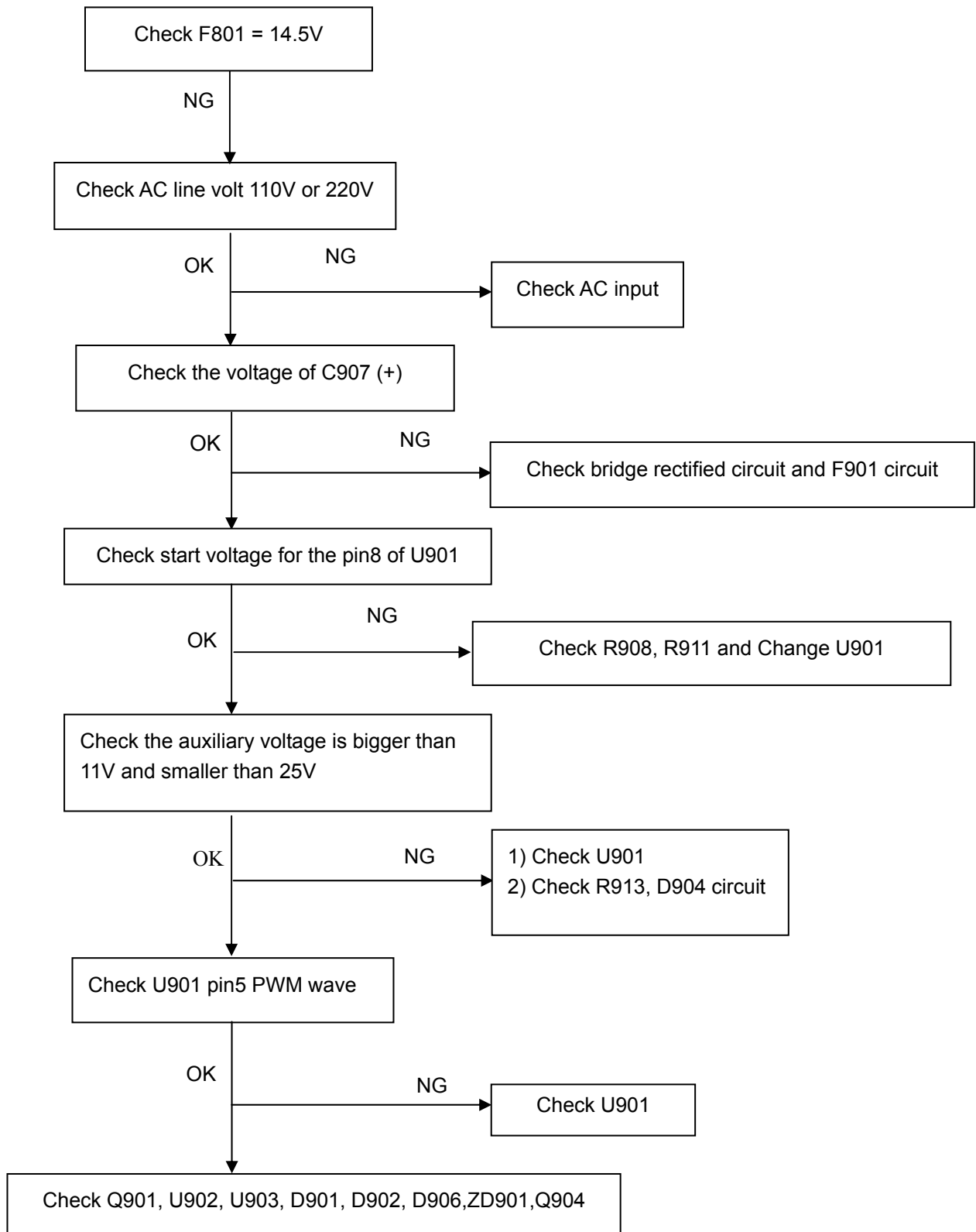

2.) No Backlight

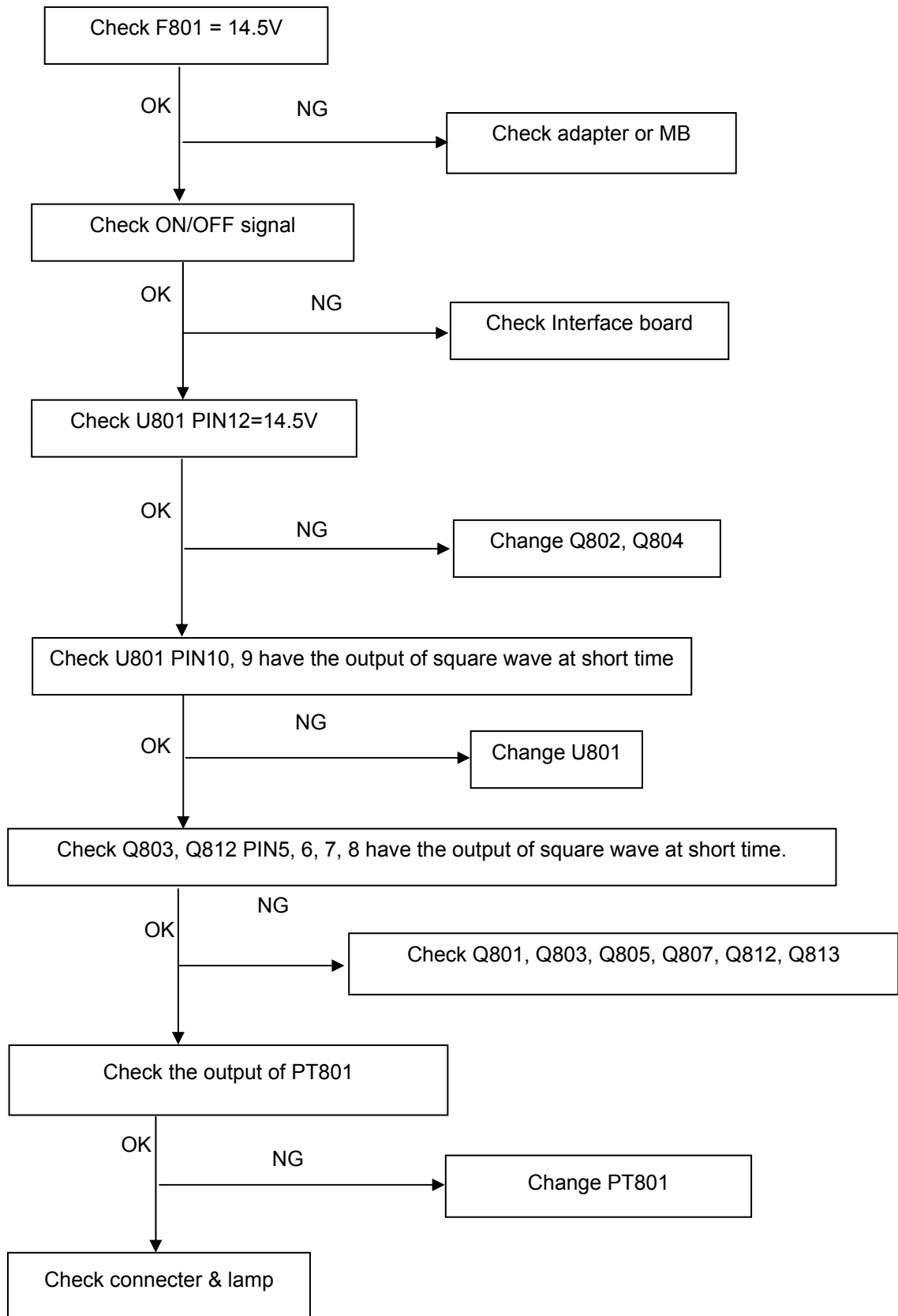

D-SUB CONNECTORS

Pin – Assignment of 15-pin D-sub:

1	Red Video	9	+5 v
2	Green Video	10	Logic Ground
3	Blue Video	11	RS232
4	RS232	12	DDC-Serial Data
5	DDC-Return	13	H-Sync.
6	Red Ground	14	V-Sync.
7	Green Ground	15	DDC-Serial Clock
8	Blue Ground		

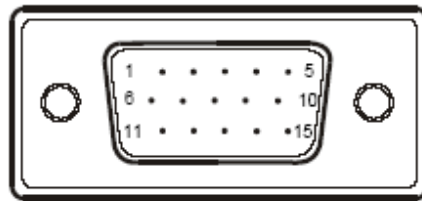

This chapter gives you the FRU (Field Replaceable Unit) listing in global configurations of X203H. Refer to this chapter whenever ordering for parts to repair or for RMA (Return Merchandise Authorization).

NOTE: Please note WHEN ORDERING FRU PARTS, that you should check the most up-to-date information available on your regional web or channel (<http://aicsl.acer.com.tw/spl/>). For whatever reasons a part number change is made, it will not be noted in the printed Service Guide. For ACER AUTHORIZED SERVICE PROVIDERS, your Acer office may have a DIFFERENT part number code from those given in the FRU list of this printed Service Guide. You MUST use the local FRU list provided by your regional Acer office to order FRU parts for repair and service of customer machines.

NOTE: To scrap or to return the defective parts, you should follow the local government ordinance or regulations on how to dispose it properly, or follow the rules set by your regional Acer office on how to return it.

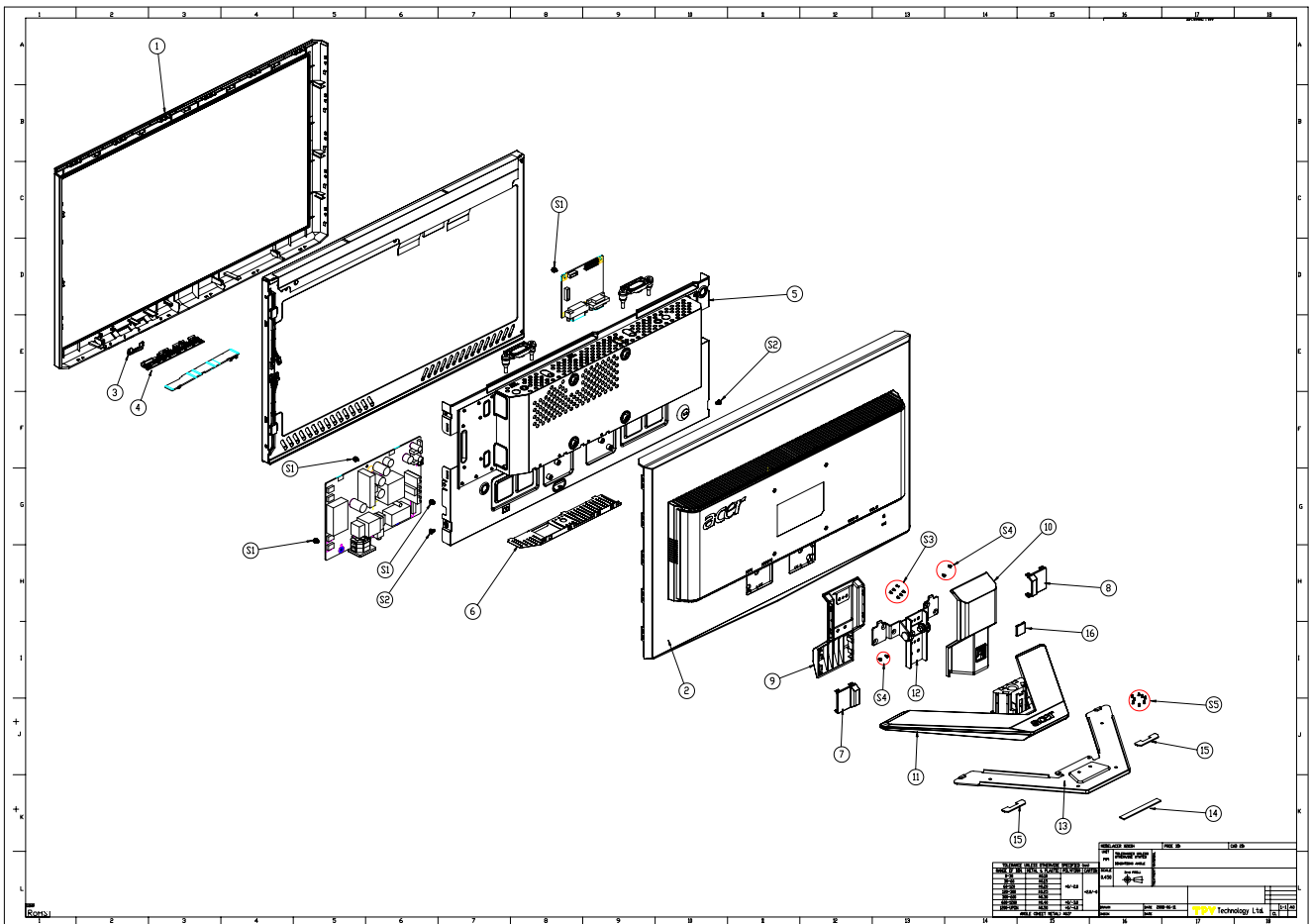

Exploded Diagram (Model: X203H)



ITEM	PART NO.	DESCRIPTION	Q'TY
1	BEZEL L20WA-8ACER3-S4 X203H	A34G1078 RXA1B0130	1
2	REAR COVER X203H	A34G1079 RX 4B0100	1
3	KEY BUTTON	Q33G0237 RX 1L0100	1
4	LED LENS	A33G0270 1 1L0100	1
5	MAINFRAME	A15G0492101401	1
6	SHIELD	A85G0135101	1
7	HINGE COVER L	A33G0271 RX 1L0200	1
8	HINGE COVER R	A33G0271 RX 2L0200	1
9	STAND FRONT	A34G0473 RX 1B0100	1
10	STAND REAR	A34G0474 RX 1B0100	1
11	BASE	A34G0475 RX 1B0130	1
12	HINGE	A37G0050 2	1
13	BASE BKT	A15G0263201	1
14	RUBER FOOT-1	A12G0006 1	1
15	RUBER FOOT-2	A12G0007 1	2
16	BASE BUTTON	A33G0266 RX 1L0100	1
S1	SCREW	0M1G1730 6120	4
S2	SCREW	0M1G 130 6120	2
S3	SCREW	0Q1G 140 10120	6
S4	SCREW	0M1G 140 8125	4
S5	SCREW	0Q1G 130 8120	8

Part List

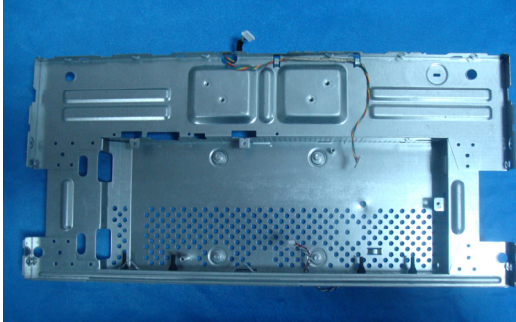
Above picture show the description of the following component.

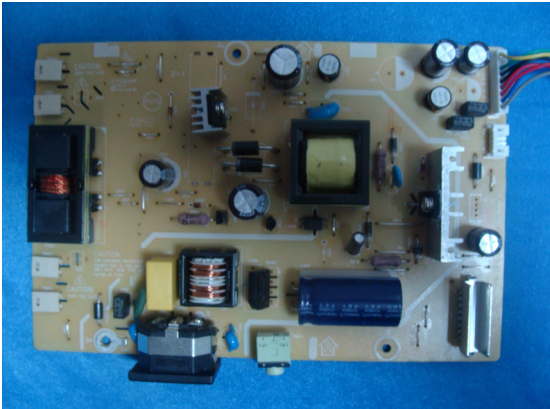
Picture	Description	Part No.
 A silver metal main frame for a laptop, showing various mounting points, screws, and a perforated section at the bottom.	Main Frame	A15G0492101401
 A black plastic bezel for a laptop screen, showing the mounting points and the screen area.	Bezel	A34G1078 RXA1B0130
 A silver metal panel for a laptop, showing the mounting points and a barcode label.	Panel	750GLS200KT112N000
 A yellow printed circuit board (PCB) for a laptop power supply, showing various electronic components like capacitors, resistors, and a transformer.	Power Board	PWPC8A41EQI3

	<p>Main Board</p>	<p>CBPCRNDABQN</p>
	<p>Key Board</p>	<p>KEPC7QK1</p>
	<p>Stand Front</p>	<p>A34G0473 RX 1B0100</p>
	<p>Base</p>	<p>A34G0475 RX 1B0130</p>
	<p>Stand Rear</p>	<p>A34G0474 RX 1B0100</p>
	<p>Hinge</p>	<p>A37G0050 2</p>

Main Board

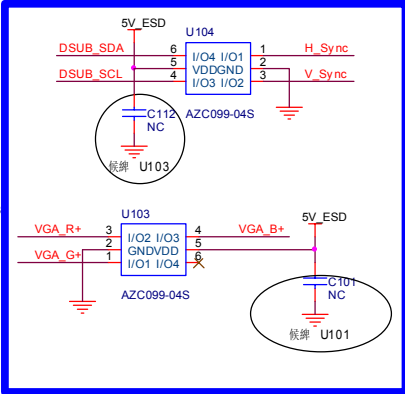
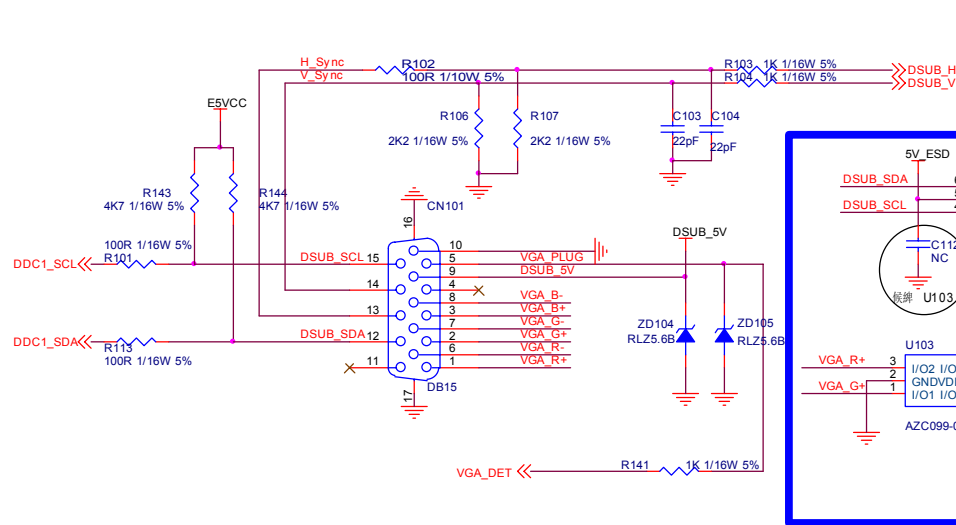

Modify in 2008/01/28

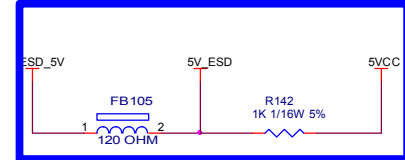
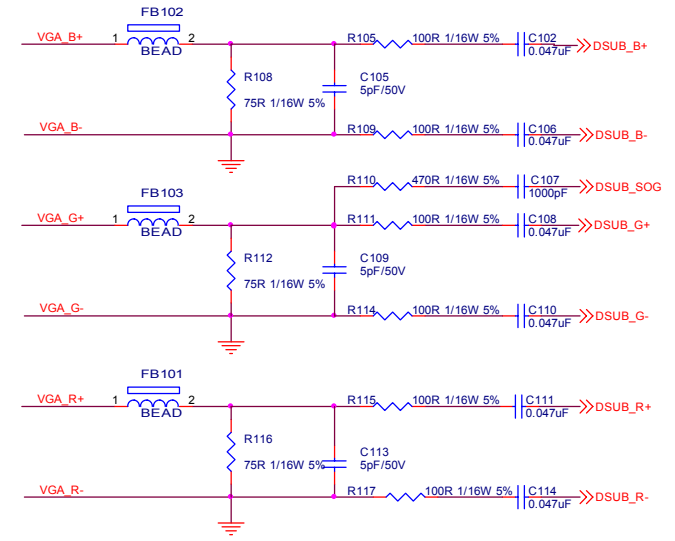

Modify in 2008/03/07



TPV (Top Victory Electronics Co., Ltd.)	OEM MODEL	Acer	Size	B
話筒瓜網膜	G3108-1-X-X-17-081119	TPV MODEL	Acer X203H Analog only	Rev
Key Component	2.0 Input	PCB NAME		
Date	Wednesday, November 19, 2008	Sheet	2 of 5	称差 <称差>

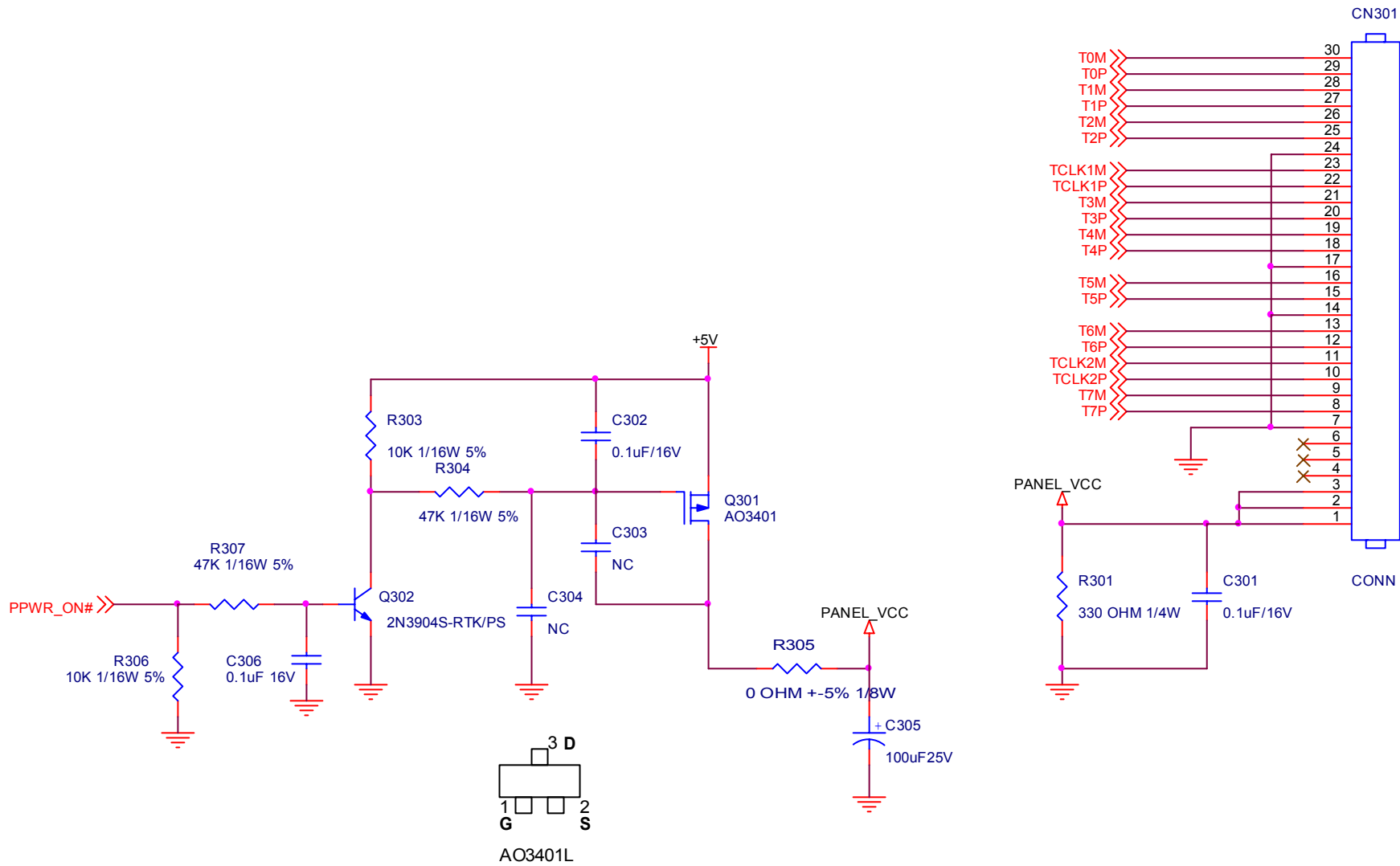

TPV (Top Victory Electronics Co., Ltd.)	OEM MODEL	Acer	Size	A
紙隔瓜網腹	G3108-1-X-X-17-081119	TPV MODEL	Acer X203H Analog only	Rev
Key Component	3.0.OUTPUT	PCB NAME		称爹
Date	Wednesday, November 19, 2008	Sheet	3 of 5	<称爹>

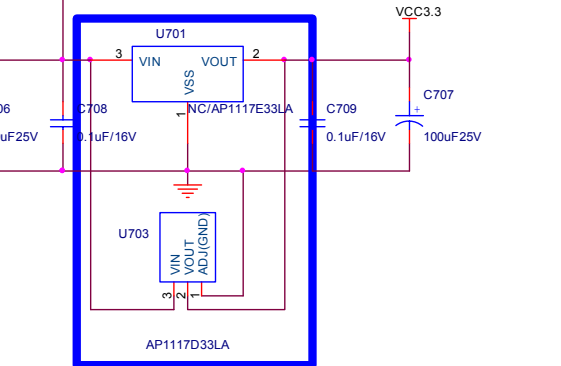
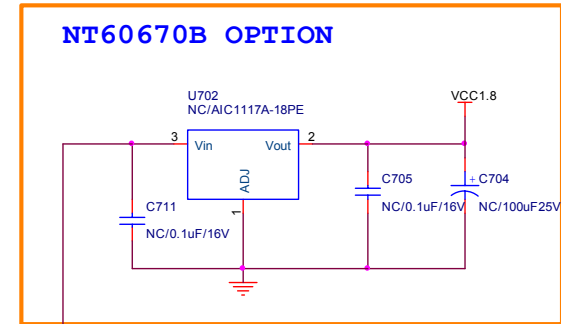
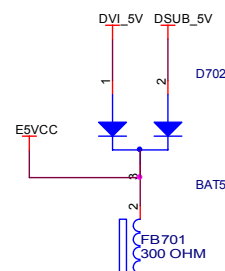
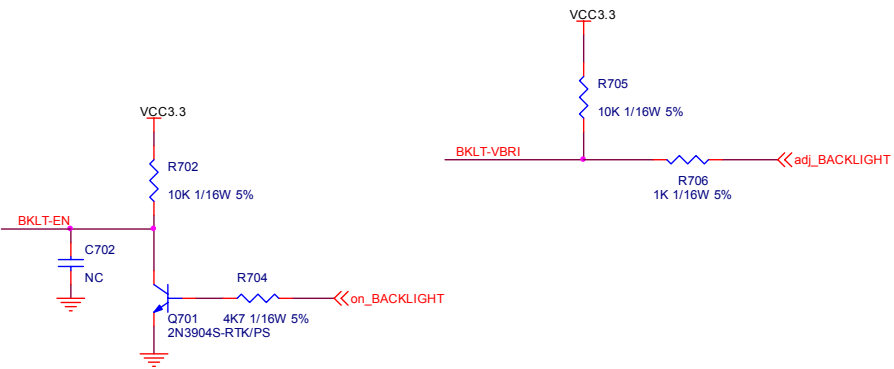
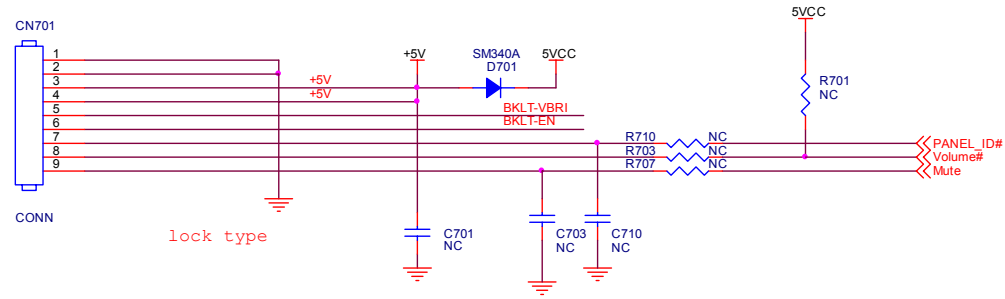

Both 223 and 252
foot-print



TPV (Top Victory Electronics Co., Ltd.)	OEM MODEL	Acer	Size	B
絲隔瓜網板 G3108-1-X-X-17-081119	TPV MODEL	Acer X203H Analog only	Rev	1
Key Component 4.0.POWER	PCB NAME		稱參	<稱參>
Date Wednesday, November 19, 2008	Sheet	4 of 5		

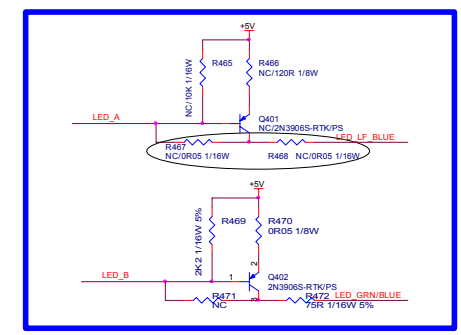
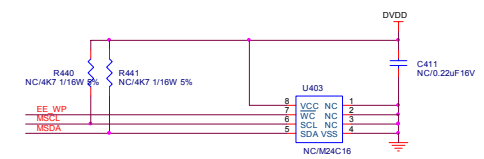
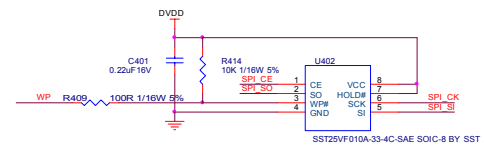
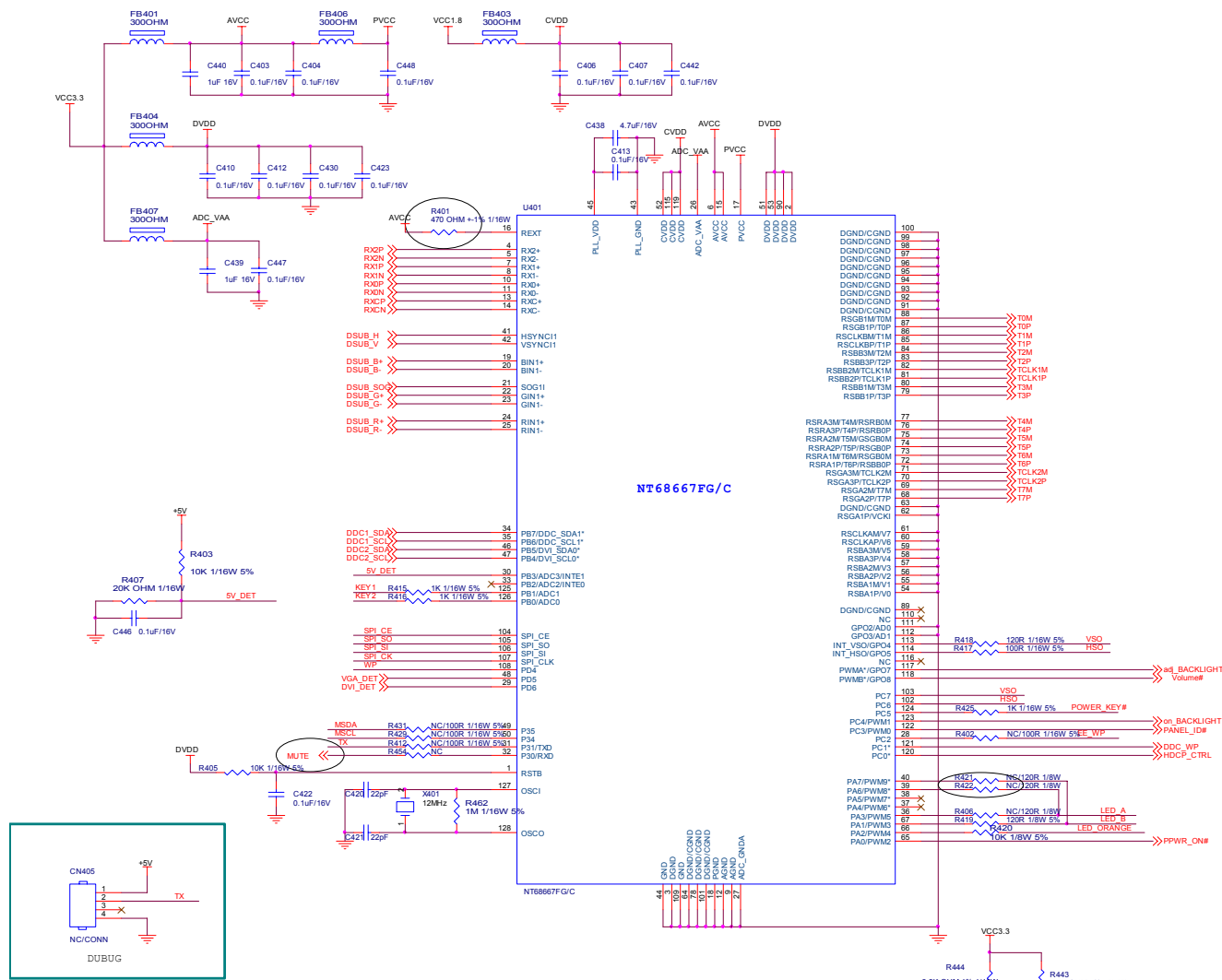

Modify in 2008/03/07

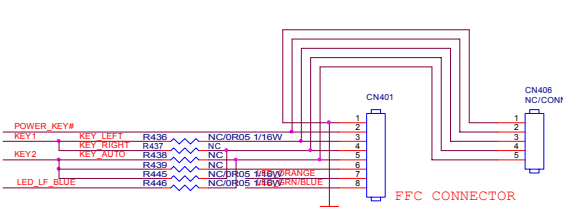

CN401 PIN1~5CN406 PIN1~5 LAY
CN402 PIN 5~7CN403 PIN1~3 LAY

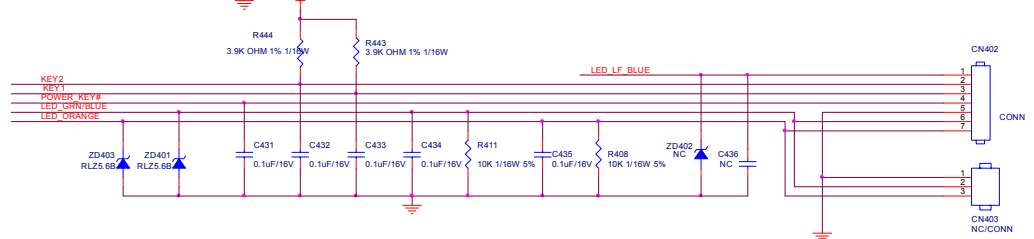

CN402 PIN 5~7CN403 PIN1~3 LAY

T P V (Top Victory Electronics Co., Ltd.)	GEM MODEL	Acer	Size	C	
规格书链接	G3108-1-XS-080818	TPV MODEL	Acer B1V203H Analog only	Rev	1
Key Component	S.O.SCALER	PCB NAME		备注	<#>
Date	Wednesday, November 19, 2008	Sheet	5 of 5		

Power board

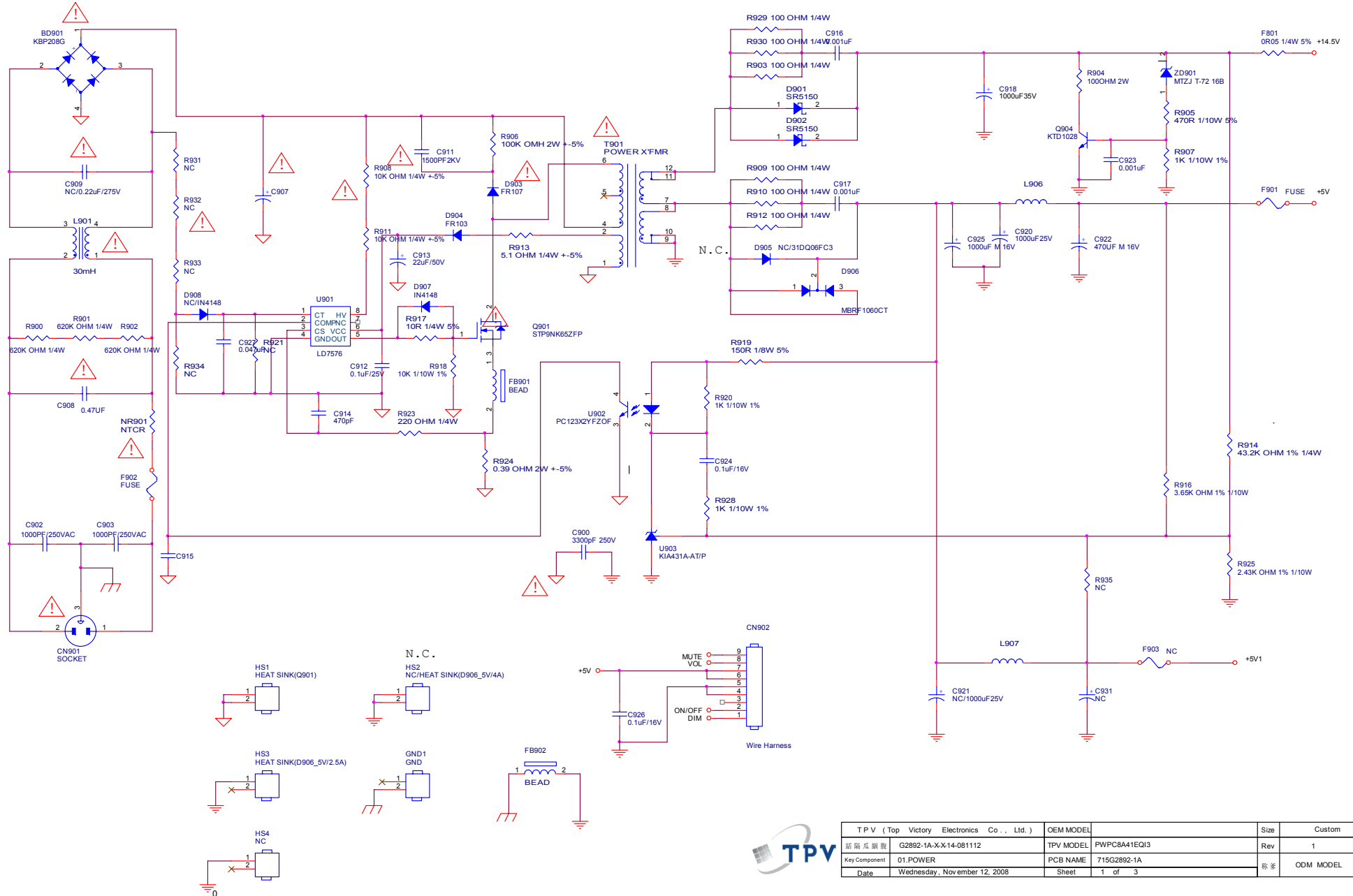

TPV (Top Victory Electronics Co., Ltd.)	OEM MODEL	Size	Custom
基爾瓜爾取	G2892-1A-X-X-14-081112	TPV MODEL	PWP/PCBA41EQI3
Key Component	01_POWER	PCB NAME	715G2892-1A
Date	Wednesday, November 12, 2008	Sheet	1 of 3
		Rev	1
		ODM MODEL	

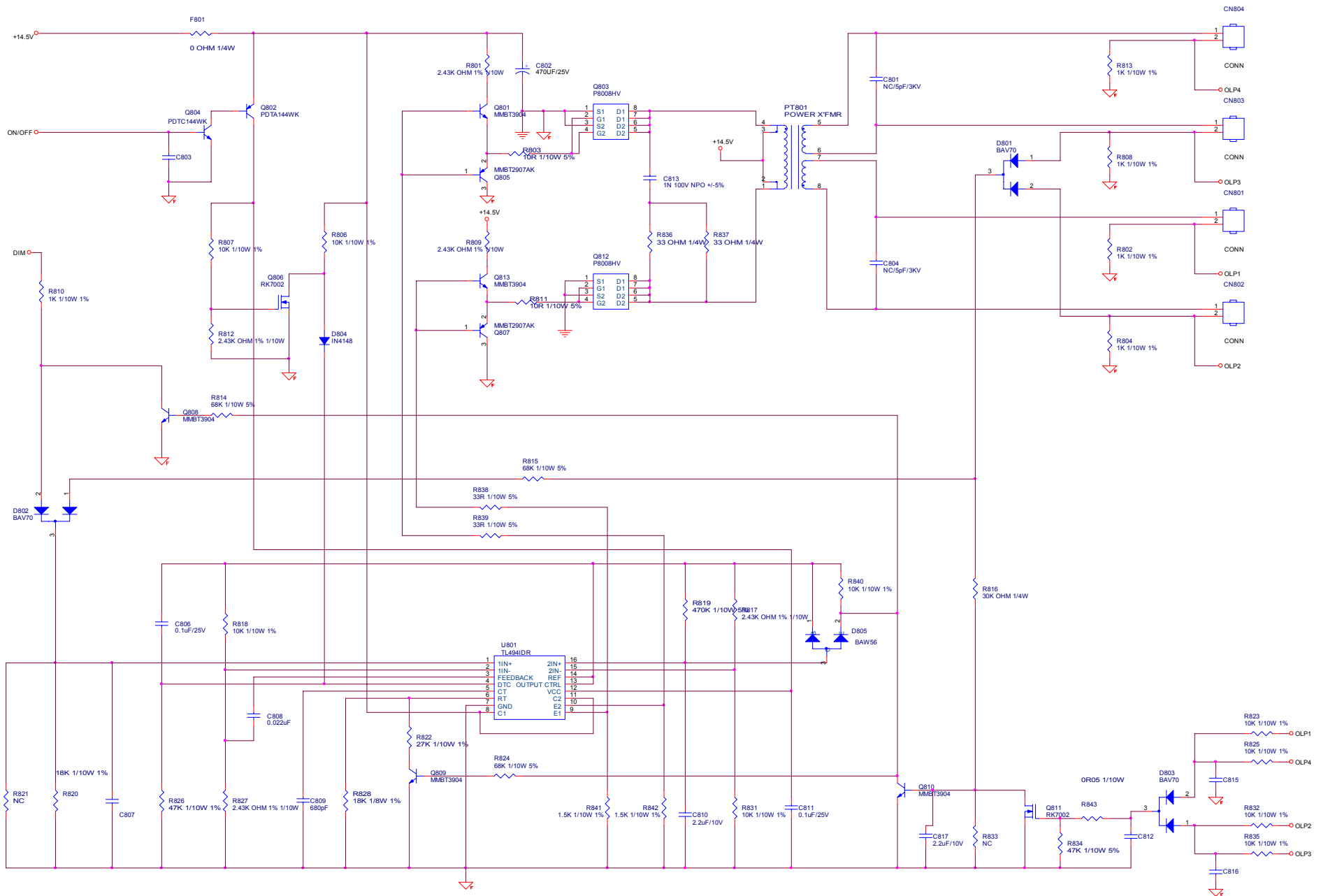

TPV (Top Victory Electronics Co., Ltd.)		OEM MODEL	Size	Custom
基點 圖號 G2892-1A-X-X-14-081112		TPV MODEL PWPC&M1EQ/3	Rev	1
Key Component 02.INVERTER		PCB NAME 715G2892-1A	標號	ODM MODEL
Date	Wednesday, November 12, 2008	Sheet 2 of 3		

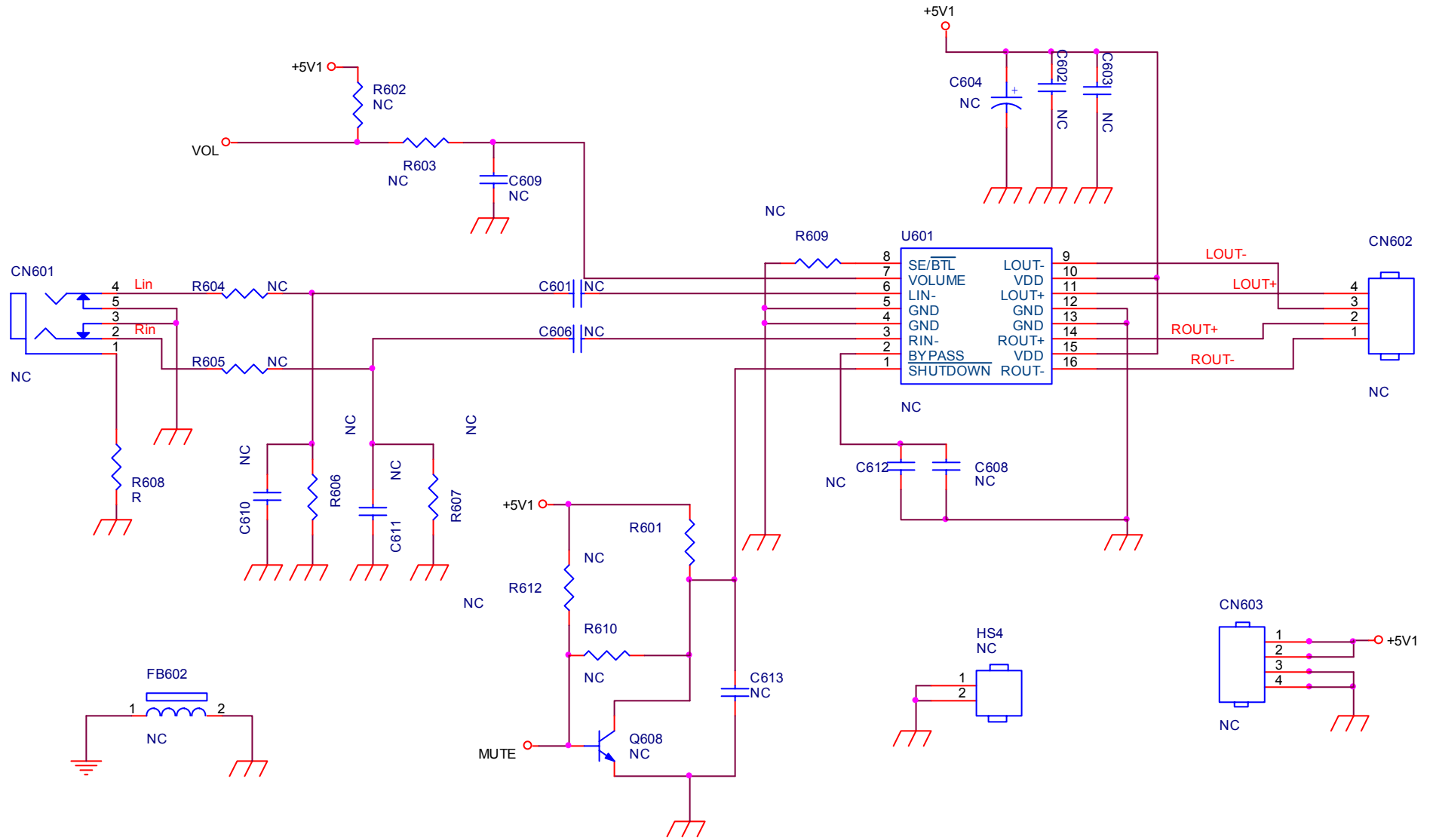

	TPV (Top Victory Electronics Co . , Ltd.)	OEM MODEL		Size	A
網隔瓜網腹	G2892-1A-X-X-14-081112	TPV MODEL	PWPC8A41EQI3	Rev	1
Key Component	04.AUDIO	PCB NAME	715G2892-1A	称爹	ODM MODEL
Date	Wednesday , Nov ember 12, 2008	Sheet	1 of 3		

Key board

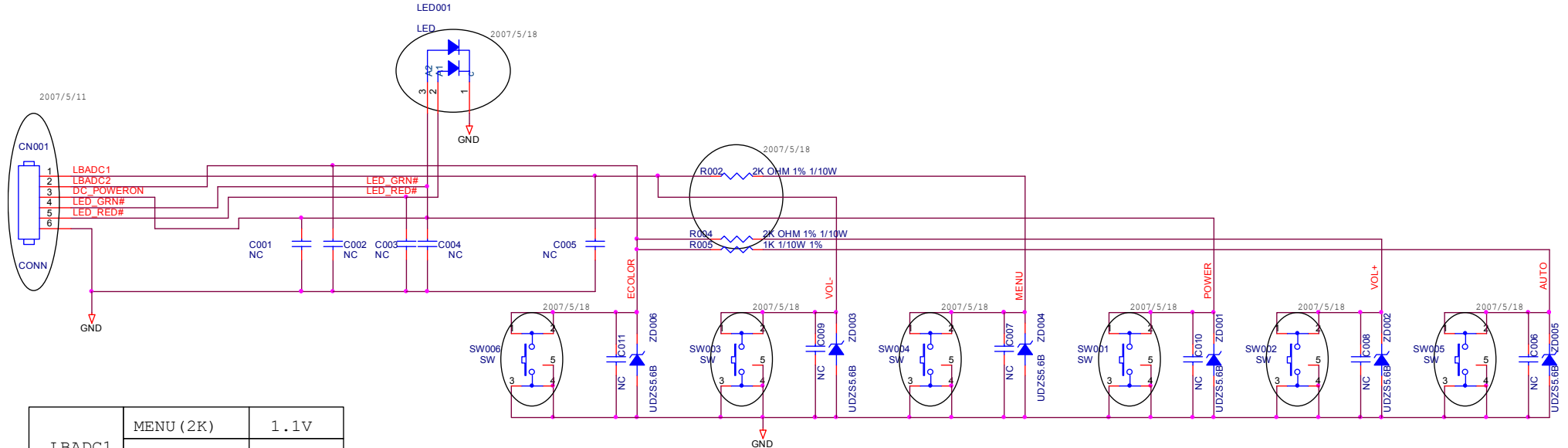

LBADC1	MENU (2K)	1.1V
	VOL- (GND)	0 V
LBADC2	VOL+ (2K)	1.1V
	AUTO (1K)	0.65V
	ECOLOR (GND)	0 V

change Net name
 MENU--->AUTO
 AUTO---->MENU

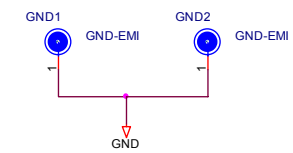
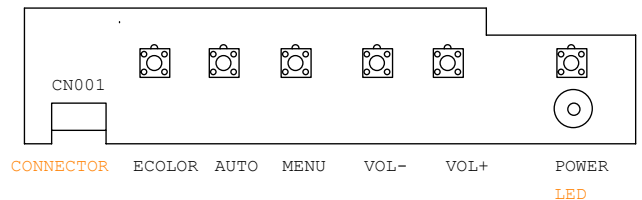

TPV (Top Victory Electronics Co., Ltd.)	OEM MODEL		Size	B
錫隔瓜網廠	G2731-B-AC-X-1-070617	TPV MODEL	ACER	Rev
Key Component	02.Key Board	PCB NAME	715G2731-B-AC	称差
Date	Sunday, June 17, 2007	Sheet	1 of 2	<称差>