



North/Latin America
Europe/Africa
Asia/Oceania

Internal Use Only

<http://aic.lgservice.com>
<http://eic.lgservice.com>
<http://biz.lgservice.com>

LED LCD TV

SERVICE MANUAL

CHASSIS : LB01B

MODEL : 42LE5300
42LE5310

42LE5300-TA
42LE5310-TC

CAUTION

BEFORE SERVICING THE CHASSIS,
READ THE SAFETY PRECAUTIONS IN THIS MANUAL.

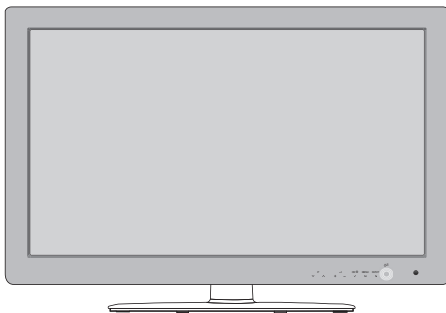

P/NO : MFL62865318 (1004-REV00)

Printed in Korea

CONTENTS

CONTENTS	2
PRODUCT SAFETY	3
SPECIFICATION	6
ADJUSTMENT INSTRUCTION	9
BLOCK DIAGRAM.....	15
EXPLODED VIEW	16
SVC. SHEET	

SAFETY PRECAUTIONS

IMPORTANT SAFETY NOTICE

Many electrical and mechanical parts in this chassis have special safety-related characteristics. These parts are identified by \triangle in the Schematic Diagram and Exploded View.

It is essential that these special safety parts should be replaced with the same components as recommended in this manual to prevent Shock, Fire, or other Hazards.

Do not modify the original design without permission of manufacturer.

General Guidance

An **isolation Transformer should always be used** during the servicing of a receiver whose chassis is not isolated from the AC power line. Use a transformer of adequate power rating as this protects the technician from accidents resulting in personal injury from electrical shocks.

It will also protect the receiver and its components from being damaged by accidental shorts of the circuitry that may be inadvertently introduced during the service operation.

If any fuse (or Fusible Resistor) in this TV receiver is blown, replace it with the specified.

When replacing a high wattage resistor (Oxide Metal Film Resistor, over 1 W), keep the resistor 10 mm away from PCB.

Keep wires away from high voltage or high temperature parts.

Before returning the receiver to the customer,

always perform an **AC leakage current check** on the exposed metallic parts of the cabinet, such as antennas, terminals, etc., to be sure the set is safe to operate without damage of electrical shock.

Leakage Current Cold Check(Antenna Cold Check)

With the instrument AC plug removed from AC source, connect an electrical jumper across the two AC plug prongs. Place the AC switch in the on position, connect one lead of ohm-meter to the AC plug prongs tied together and touch other ohm-meter lead in turn to each exposed metallic parts such as antenna terminals, phone jacks, etc.

If the exposed metallic part has a return path to the chassis, the measured resistance should be between 1 M Ω and 5.2 M Ω .

When the exposed metal has no return path to the chassis the reading must be infinite.

An other abnormality exists that must be corrected before the receiver is returned to the customer.

Leakage Current Hot Check (See below Figure)

Plug the AC cord directly into the AC outlet.

Do not use a line Isolation Transformer during this check.

Connect 1.5 K / 10 watt resistor in parallel with a 0.15 μ F capacitor between a known good earth ground (Water Pipe, Conduit, etc.) and the exposed metallic parts.

Measure the AC voltage across the resistor using AC voltmeter with 1000 ohms/volt or more sensitivity.

Reverse plug the AC cord into the AC outlet and repeat AC voltage measurements for each exposed metallic part. Any voltage measured must not exceed 0.75 volt RMS which corresponds to 0.5 mA.

In case any measurement is out of the limits specified, there is possibility of shock hazard and the set must be checked and repaired before it is returned to the customer.

Leakage Current Hot Check circuit

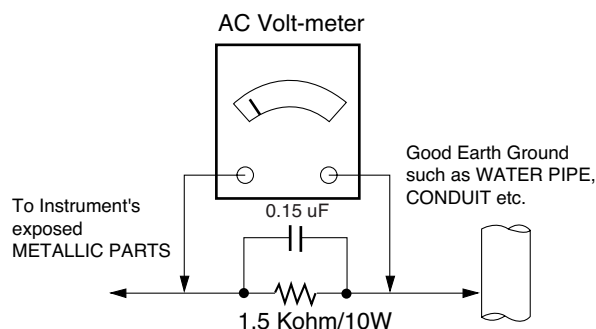

When 25A is impressed between Earth and 2nd Ground for 1 second, Resistance must be less than 0.1 Ω

*Base on Adjustment standard

SERVICING PRECAUTIONS

CAUTION: Before servicing receivers covered by this service manual and its supplements and addenda, read and follow the SAFETY PRECAUTIONS on page 3 of this publication.

NOTE: If unforeseen circumstances create conflict between the following servicing precautions and any of the safety precautions on page 3 of this publication, always follow the safety precautions. Remember: Safety First.

General Servicing Precautions

1. Always unplug the receiver AC power cord from the AC power source before;
 - a. Removing or reinstalling any component, circuit board module or any other receiver assembly.
 - b. Disconnecting or reconnecting any receiver electrical plug or other electrical connection.
 - c. Connecting a test substitute in parallel with an electrolytic capacitor in the receiver.
CAUTION: A wrong part substitution or incorrect polarity installation of electrolytic capacitors may result in an explosion hazard.
2. Test high voltage only by measuring it with an appropriate high voltage meter or other voltage measuring device (DVM, FETVOM, etc) equipped with a suitable high voltage probe. Do not test high voltage by "drawing an arc".
3. Do not spray chemicals on or near this receiver or any of its assemblies.
4. Unless specified otherwise in this service manual, clean electrical contacts only by applying the following mixture to the contacts with a pipe cleaner, cotton-tipped stick or comparable non-abrasive applicator; 10 % (by volume) Acetone and 90 % (by volume) isopropyl alcohol (90 % - 99 % strength)
CAUTION: This is a flammable mixture.
Unless specified otherwise in this service manual, lubrication of contacts is not required.
5. Do not defeat any plug/socket B+ voltage interlocks with which receivers covered by this service manual might be equipped.
6. Do not apply AC power to this instrument and/or any of its electrical assemblies unless all solid-state device heat sinks are correctly installed.
7. Always connect the test receiver ground lead to the receiver chassis ground before connecting the test receiver positive lead.
Always remove the test receiver ground lead last.
8. Use with this receiver only the test fixtures specified in this service manual.
CAUTION: Do not connect the test fixture ground strap to any heat sink in this receiver.

Electrostatically Sensitive (ES) Devices

Some semiconductor (solid-state) devices can be damaged easily by static electricity. Such components commonly are called Electrostatically Sensitive (ES) Devices. Examples of typical ES devices are integrated circuits and some field-effect transistors and semiconductor "chip" components. The following techniques should be used to help reduce the incidence of component damage caused by static by static electricity.

1. Immediately before handling any semiconductor component or semiconductor-equipped assembly, drain off any electrostatic charge on your body by touching a known earth ground. Alternatively, obtain and wear a commercially available discharging wrist strap device, which should be removed to prevent potential shock reasons prior to applying power to the unit under test.

2. After removing an electrical assembly equipped with ES devices, place the assembly on a conductive surface such as aluminum foil, to prevent electrostatic charge buildup or exposure of the assembly.
3. Use only a grounded-tip soldering iron to solder or unsolder ES devices.
4. Use only an anti-static type solder removal device. Some solder removal devices not classified as "anti-static" can generate electrical charges sufficient to damage ES devices.
5. Do not use freon-propelled chemicals. These can generate electrical charges sufficient to damage ES devices.
6. Do not remove a replacement ES device from its protective package until immediately before you are ready to install it. (Most replacement ES devices are packaged with leads electrically shorted together by conductive foam, aluminum foil or comparable conductive material).
7. Immediately before removing the protective material from the leads of a replacement ES device, touch the protective material to the chassis or circuit assembly into which the device will be installed.
CAUTION: Be sure no power is applied to the chassis or circuit, and observe all other safety precautions.
8. Minimize bodily motions when handling unpackaged replacement ES devices. (Otherwise harmless motion such as the brushing together of your clothes fabric or the lifting of your foot from a carpeted floor can generate static electricity sufficient to damage an ES device.)

General Soldering Guidelines

1. Use a grounded-tip, low-wattage soldering iron and appropriate tip size and shape that will maintain tip temperature within the range or 500 °F to 600 °F.
2. Use an appropriate gauge of RMA resin-core solder composed of 60 parts tin/40 parts lead.
3. Keep the soldering iron tip clean and well tinned.
4. Thoroughly clean the surfaces to be soldered. Use a mall wire-bristle (0.5 inch, or 1.25 cm) brush with a metal handle. Do not use freon-propelled spray-on cleaners.
5. Use the following unsoldering technique
 - a. Allow the soldering iron tip to reach normal temperature. (500 °F to 600 °F)
 - b. Heat the component lead until the solder melts.
 - c. Quickly draw the melted solder with an anti-static, suction-type solder removal device or with solder braid.
CAUTION: Work quickly to avoid overheating the circuit board printed foil.
6. Use the following soldering technique.
 - a. Allow the soldering iron tip to reach a normal temperature (500 °F to 600 °F)
 - b. First, hold the soldering iron tip and solder the strand against the component lead until the solder melts.
 - c. Quickly move the soldering iron tip to the junction of the component lead and the printed circuit foil, and hold it there only until the solder flows onto and around both the component lead and the foil.
CAUTION: Work quickly to avoid overheating the circuit board printed foil.
 - d. Closely inspect the solder area and remove any excess or splashed solder with a small wire-bristle brush.

IC Remove/Replacement

Some chassis circuit boards have slotted holes (oblong) through which the IC leads are inserted and then bent flat against the circuit foil. When holes are the slotted type, the following technique should be used to remove and replace the IC. When working with boards using the familiar round hole, use the standard technique as outlined in paragraphs 5 and 6 above.

Removal

1. Desolder and straighten each IC lead in one operation by gently prying up on the lead with the soldering iron tip as the solder melts.
2. Draw away the melted solder with an anti-static suction-type solder removal device (or with solder braid) before removing the IC.

Replacement

1. Carefully insert the replacement IC in the circuit board.
2. Carefully bend each IC lead against the circuit foil pad and solder it.
3. Clean the soldered areas with a small wire-bristle brush. (It is not necessary to reapply acrylic coating to the areas).

"Small-Signal" Discrete Transistor

Removal/Replacement

1. Remove the defective transistor by clipping its leads as close as possible to the component body.
2. Bend into a "U" shape the end of each of three leads remaining on the circuit board.
3. Bend into a "U" shape the replacement transistor leads.
4. Connect the replacement transistor leads to the corresponding leads extending from the circuit board and crimp the "U" with long nose pliers to insure metal to metal contact then solder each connection.

Power Output, Transistor Device

Removal/Replacement

1. Heat and remove all solder from around the transistor leads.
2. Remove the heat sink mounting screw (if so equipped).
3. Carefully remove the transistor from the heat sink of the circuit board.
4. Insert new transistor in the circuit board.
5. Solder each transistor lead, and clip off excess lead.
6. Replace heat sink.

Diode Removal/Replacement

1. Remove defective diode by clipping its leads as close as possible to diode body.
2. Bend the two remaining leads perpendicular y to the circuit board.
3. Observing diode polarity, wrap each lead of the new diode around the corresponding lead on the circuit board.
4. Securely crimp each connection and solder it.
5. Inspect (on the circuit board copper side) the solder joints of the two "original" leads. If they are not shiny, reheat them and if necessary, apply additional solder.

Fuse and Conventional Resistor

Removal/Replacement

1. Clip each fuse or resistor lead at top of the circuit board hollow stake.
2. Securely crimp the leads of replacement component around notch at stake top.
3. Solder the connections.

CAUTION: Maintain original spacing between the replaced component and adjacent components and the circuit board to prevent excessive component temperatures.

Circuit Board Foil Repair

Excessive heat applied to the copper foil of any printed circuit board will weaken the adhesive that bonds the foil to the circuit board causing the foil to separate from or "lift-off" the board. The following guidelines and procedures should be followed whenever this condition is encountered.

At IC Connections

To repair a defective copper pattern at IC connections use the following procedure to install a jumper wire on the copper pattern side of the circuit board. (Use this technique only on IC connections).

1. Carefully remove the damaged copper pattern with a sharp knife. (Remove only as much copper as absolutely necessary).
2. Carefully scratch away the solder resist and acrylic coating (if used) from the end of the remaining copper pattern.
3. Bend a small "U" in one end of a small gauge jumper wire and carefully crimp it around the IC pin. Solder the IC connection.
4. Route the jumper wire along the path of the out-away copper pattern and let it overlap the previously scraped end of the good copper pattern. Solder the overlapped area and clip off any excess jumper wire.

At Other Connections

Use the following technique to repair the defective copper pattern at connections other than IC Pins. This technique involves the installation of a jumper wire on the component side of the circuit board.

1. Remove the defective copper pattern with a sharp knife. Remove at least 1/4 inch of copper, to ensure that a hazardous condition will not exist if the jumper wire opens.
2. Trace along the copper pattern from both sides of the pattern break and locate the nearest component that is directly connected to the affected copper pattern.
3. Connect insulated 20-gauge jumper wire from the lead of the nearest component on one side of the pattern break to the lead of the nearest component on the other side. Carefully crimp and solder the connections.

CAUTION: Be sure the insulated jumper wire is dressed so the it does not touch components or sharp edges.

SPECIFICATION

NOTE : Specifications and others are subject to change without notice for improvement.

1. Application range

This specification is applied to the LCD TV used LB01B chassis.

2. Requirement for Test

Each part is tested as below without special appointment.

- 1) Temperature : 25 °C ± 5 °C (77 °F ± 9 °F), CST : 40 °C ± 5 °C
- 2) Relative Humidity : 65 % ± 10 %
- 3) Power Voltage : Standard input voltage (AC 100-240 V~ 50 / 60 Hz)
* Standard Voltage of each products is marked by models.
- 4) Specification and performance of each parts are followed each drawing and specification by part number in accordance with BOM.
- 5) The receiver must be operated for about 5 minutes prior to the adjustment.

3. Test method

- 1) Performance: LGE TV test method followed
- 2) Demanded other specification
 - Safety: CE, IEC specification
 - EMC:CE, IEC

4. Module optical specifications

- LGD Module

No.	Item	Specification	Min.	Typ.	Max.	Remark
1.	Viewing Angle (CR > 10)	Up/Down(Right/Left)	178			Degree
2.	Luminance	Luminance (cd/m ²)	350	450		
		Variation		-	1.3	MAX / MIN
3.	Contrast Ratio	CR	1000	1400		
4.	CIE Color Coordinates	White	Typ. -0.03	Wx	Typ. +0.03	
				Wy		
		RED		Rx		
				Ry		
		Green		Gx		
				Gy		
		Blue		Bx		
				By		

- 1) Standard Test Condition (The unit has been 'ON')
- 2) Stable for approximately 30 minutes in a dark environment at 25 °C ± 2 °C.
- 3) The values specified are at approximate distance 50 cm from the LCD surface.
- 4) Ta = 25 °C ± 2 °C, VLCD = 12.0 V, fv = 60 Hz, Dclk = 74.25 MHz, VBR_A = 1.65 V, EXTV_{BR-B} = 100 %

5. Component Video Input (Y, Cb/Pb, Cr/Pr)

No.	Specification				Remark
	Resolution	H-freq(kHz)	V-freq(Hz)		
1.	720x480	15.73	60.00	SDTV,DVD 480i	
2.	720x480	15.63	59.94	SDTV,DVD 480i	
3.	720x480	31.47	59.94	480p	
4.	720x480	31.50	60.00	480p	
5.	720x576	15.625	50.00	SDTV,DVD 625 Line	
6.	720x576	31.25	50.00	HDTV 576p	
7.	1280x720	45.00	50.00	HDTV 720p	
8.	1280x720	44.96	59.94	HDTV 720p	
9.	1280x720	45.00	60.00	HDTV 720p	
10.	1920x1080	31.25	50.00	HDTV 1080i	
11.	1920x1080	33.75	60.00	HDTV 1080i	
12.	1920x1080	33.72	59.94	HDTV 1080i	
13.	1920x1080	56.250	50	HDTV 1080p	
14.	1920x1080	67.5	60	HDTV 1080p	

6. RGB (PC)

No.	Specification				Proposed	Remark
	Resolution	H-freq(kHz)	V-freq(Hz)	Pixel Clock(MHz)		
1.	720*400	31.468	70.08	28.321		For only DOS mode
2.	640*480	31.469	59.94	25.17	VESA	Input 848*480 60 Hz, 852*480 60 Hz -> 640*480 60 Hz Display
3.	800*600	37.879	60.31	40.00	VESA	
4.	1024*768	48.363	60.00	65.00	VESA(XGA)	
5.	1280*768	47.78	59.87	79.5	WXGA	
6.	1360*768	47.72	59.8	84.75	WXGA	
7.	1280*1024	63.981	60.02	108.875	SXGA	FHD Model
8.	1920*1080	66.587	59.93	138.625	WUXGA	FHD model

7. HDMI Input

(1) DTV Mode

No.	Resolution	H-freq(kHz)	V-freq.(Hz)	Pixel clock(MHz)	Proposed	Remark
1.	720*480	31.469 /31.5	59.94 /60	27.00/27.03	SDTV 480P	
2.	720*576	31.25	50	54	SDTV 576P	
3.	1280*720	37.500	50	74.25	HDTV 720P	
4.	1280*720	44.96 /45	59.94 /60	74.17/74.25	HDTV 720P	
5.	1920*1080	33.72 /33.75	59.94 /60	74.17/74.25	HDTV 1080I	
6.	1920*1080	28.125	50.00	74.25	HDTV 1080I	
7.	1920*1080	26.97 /27	23.97 /24	74.17/74.25	HDTV 1080P	
8.	1920*1080	33.716 /33.75	29.976 /30.00	74.25	HDTV 1080P	
9.	1920*1080	56.250	50	148.5	HDTV 1080P	
10.	1920*1080	67.43 /67.5	59.94 /60	148.35/148.50	HDTV 1080P	

(2) PC Mode

No.	Resolution	H-freq(kHz)	V-freq.(Hz)	Pixel clock(MHz)	Proposed	Remark
1.	720*400	31.468	70.08	28.321		HDCP
2.	640*480	31.469	59.94	25.17	VESA	HDCP
3.	800*600	37.879	60.31	40.00	VESA	HDCP
4.	1024*768	48.363	60.00	65.00	VESA(XGA)	HDCP
5.	1280*768	47.78	59.87	79.5	WXGA	HDCP
6.	1360*768	47.72	59.8	84.75	WXGA	HDCP
7.	1280*1024	63.981	60.02	108.875	SXGA	HDCP/FHD model
8.	1920*1080	67.5	60.00	138.625	WUXGA	HDCP/FHD model

ADJUSTMENT INSTRUCTION

1. Application Range

This specification sheet is applied to all of the LCD TV with LB01B chassis.

2. Designation

- 1) The adjustment is according to the order which is designated and which must be followed, according to the plan which can be changed only on agreeing.
- 2) Power Adjustment: Free Voltage
- 3) Magnetic Field Condition: Nil.
- 4) Input signal Unit: Product Specification Standard
- 5) Reserve after operation: Above 5 Minutes (Heat Run)
Temperature : at 25 °C ± 5 °C
Relative humidity : 65 % ± 10 %
Input voltage : 220 V, 60 Hz
- 6) Adjustment equipments: Color Analyzer(CA-210 or CA-110), DDC Adjustment Jig equipment, Service remote control.
- 7) Push the "IN STOP" key - For memory initialization.

Case1 : Software version up

1. After downloading S/W by USB, TV set will reboot automatically
2. Push "In-stop" key
3. Push "Power on" key
4. Function inspection
5. After function inspection, Push "In-stop" key.

Case2 : Function check at the assembly line

1. When TV set is entering on the assembly line, Push "In-stop" key at first.
2. Push "Power on" key for turning it on.
-> If you push "Power on" key, TV set will recover channel information by itself.
3. After function inspection, Push "In-stop" key.

3. Main PCB check process

* APC - After Manual-Insult, executing APC

* Boot file Download

- 1) Execute ISP program "Mstar ISP Utility" and then click "Config" tab.

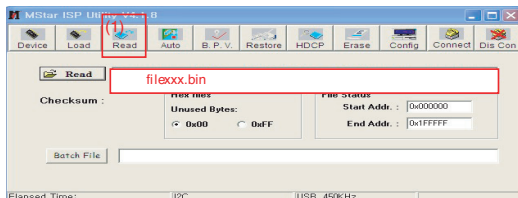

- 2) Set as below, and then click "Auto Detect" and check "OK" message
If "Error" is displayed, Check connection between computer, jig, and set.
- 3) Click "Read" tab, and then load download file (XXXX.bin) by clicking "Read"
- 4) Click "Connect" tab. If "Can't" is displayed, check connection between computer, jig, and set.

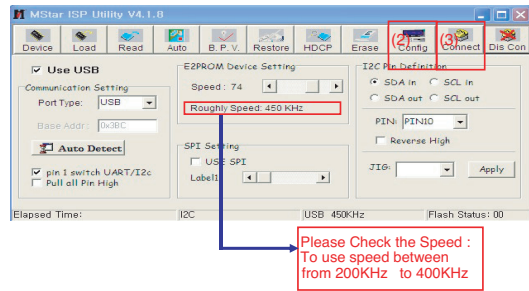

- 5) Click "Auto" tab and set as below
- 6) Click "Run".
- 7) After downloading, check "OK" message.

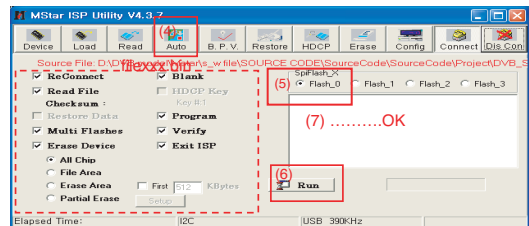

* USB DOWNLOAD

- 1) Put the USB Stick to the USB socket
- 2) Automatically detecting update file in USB Stick
- If your downloaded program version in USB Stick is Low, it didn't work. But your downloaded version is High, USB data is automatically detecting
- 3) Show the message "Copying files from memory"

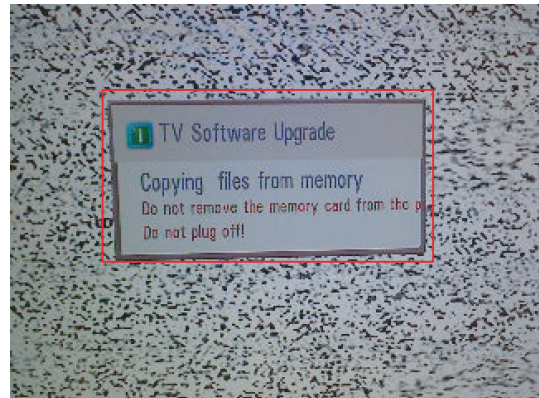

4) Updating is starting.

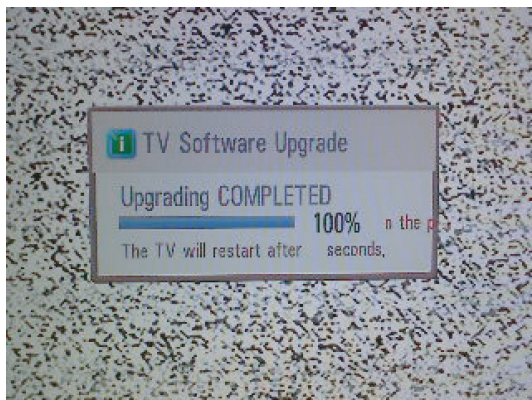
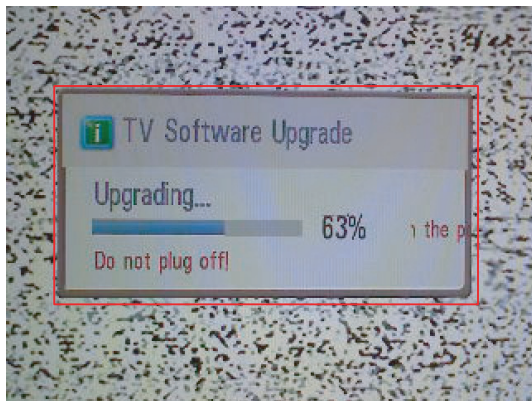

- 5) Uploading completed, The TV will restart automatically.
 6) If your TV is turned on, check your updated version and Tool option.(explain the Tool option, next stage)
 * If downloading version is more high than your TV have, TV can lost all channel data. In this case, you have to channel recover. if all channel data is cleared, you didn't have a DTV/ATV test on production line.

*** After downloading, have to adjust Tool Option again.**

- 1) Push "IN-START" key in service remote control.
- 2) Select "Tool Option 1" and Push "OK" button.
- 3) Punch in the number. (Each model has their number)

Module	Tool option1	Tool option2	Tool option3	Tool option4	Tool option5
LGD	24801	27666	56332	26892	40

4) Completed selecting Tool option.

3.1. ADC Process

(1) ADC

- Enter Service Mode by pushing "ADJ" key,
- Enter Internal ADC mode by pushing "▶" key at "5. ADC Calibration"

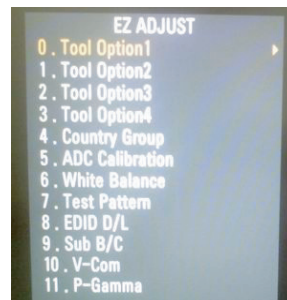

<Caution> Using 'power on' button of the Adjustment R/C, power on TV.

*** ADC Calibration Protocol (RS232)**

No	Item	CMD1	CMD2	Data0	
Enter Adjust Mode	Adjust 'Mode In'	A	A	0 0	When transfer the 'Mode In', Carry the command.
ADC adjust	ADC Adjust	A	D	1 0	Automatically adjustment (The use of a internal pattern)

Adjust Sequence

- aa 00 00 [Enter Adjust Mode]
- xb 00 40 [Component1 Input (480i)]
- ad 00 10 [Adjust 480i Comp1]
- xb 00 60 [RGB Input (1024*768)]
- ad 00 10 [Adjust 1024*768 RGB]
- aa 00 90 End Adjust mode
- * Required equipment : Adjustment R/C.

3.2. Function Check

- * Check display and sound
- Check Input and Signal items. (cf. work instructions)
 - 1) TV
 - 2) AV (SCART1/SCART2/ CVBS)
 - 3) COMPONENT (480i)
 - 4) RGB (PC : 1024 x 768 @ 60 Hz)
 - 5) HDMI
 - 6) PC Audio In
- * Display and Sound check is executed by Remote control.

4. Total Assembly line process

4.1. Adjustment Preparation

- W/B Equipment condition
CA210 : CH 9, Test signal : Inner pattern (85IRE)
- Above 5 minutes H/run in the inner pattern. ("power on" key of adjust remote control)

Cool	13,000	K	X=0.269(±0.002)	<Test Signal> Inner pattern (216 gray,85 IRE)
			Y=0.273(±0.002)	
Medium	9,300	K	X=0.285(±0.002)	
			Y=0.293(±0.002)	
Warm	6,500	K	X=0.313(±0.002)	
			Y=0.329(±0.002)	

- Edge LED W/B Table is process of time(Only LGD)
CA210 : CH 14, Test signal : Inner pattern (85 IRE)

Color Temperature	Time	Cool		Medium		Warm	
		X	Y	X	Y	X	Y
		0-2 Minute	276	285	292	305	315
3-5 Minute	274	282	290	302	313	332	
6-9 Minute	273	280	289	300	312	330	
10-19 Minute	272	278	288	298	311	328	
20-35 Minute	271	276	287	296	310	326	
36-49 Minute	269	274	286	294	309	324	
50-79 Minute	269	273	286	293	308	323	
More than 80 Minute	269	273	285	293	308	323	

- Connecting picture of the measuring instrument (On Automatic control)

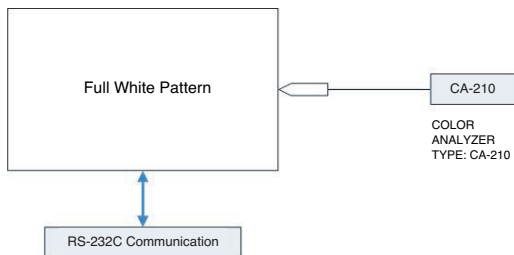

Inside PATTERN is used when W/B is controlled. Connect to auto controller or push Adjustment R/C POWER ON -> Enter the mode of White-Balance, the pattern will come out.

- Auto-control interface and directions

- Adjust in the place where the influx of light like floodlight around is blocked. (illumination is less than 10 lux).
- Adhere closely the Color Analyzer (CA210) to the module less than 10 cm distance, keep it with the surface of the Module and Color Analyzer's prove vertically.(80° ~ 100°).
- Aging time
 - After aging start, keep the power on (no suspension of power supply) and heat-run over 5 minutes.
 - Using 'no signal' or 'full white pattern' or the others, check the back light on.

- Auto adjustment Map(RS-232C)

```
RS-232C COMMAND
[CMD ID DATA]
Wb 00 00      White Balance Start
Wb 00 ff      White Balance End
```

	RS-232C COMMAND [CMD ID DATA]			MIN	CENTER (DEFAULT)			MAX
	Cool	Mid	Warm		Cool	Mid	Warm	
	R Gain	jg	Ja		jd	00	172	
G Gain	jh	Jb	je	00	172	192	192	192
B Gain	ji	Jc	jf	00	192	192	172	192
R Cut					64	64	64	128
G Cut					64	64	64	128
B Cut					64	64	64	128

<Caution>

Color Temperature : COOL, Medium, Warm.
One of R Gain/G Gain/ B Gain should be kept on 0xC0, and adjust other two lower than C0.
(when R/G/B Gain are all C0, it is the FULL Dynamic Range of Module)

- Manual W/B process using adjusts Remote control.

- After enter Service Mode by pushing "ADJ" key,
- Enter White Balance by pushing "▶" key at "6. White Balance".

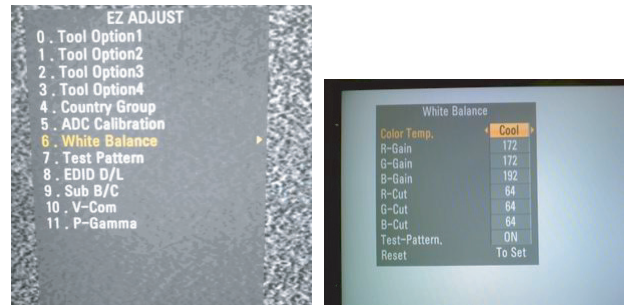

- After done all adjustments, Press "In-start" button and compare Tool option and Area option value with its BOM, if it is correctly same then unplug the AC cable. If it is not same, then correct it same with BOM and unplug AC cable. For correct it to the model's module from factory Jig model.
- Push the "IN STOP" key after completing the function inspection. And Mechanical Power Switch must be set "ON".

4.2. DDC EDID Write (RGB 128Byte)

- Connect D-sub Signal Cable to D-sub Jack.
- Write EDID Data to EEPROM(24C02) by using DDC2B protocol.
- Check whether written EDID data is correct or not.
- For SVC main Assembly, EDID have to be downloaded to Insert Process in advance.

4.3. DDC EDID Write (HDMI 256Byte)

- Connect HDMI Signal Cable to HDMI Jack.
- Write EDID data to EEPROM(24C02) by using DDC2B protocol.
- Check whether written EDID data is correct or not.
- For SVC main Assembly, EDID have to be downloaded to Insert Process in advance.

4.4. EDID DATA

- All Data : HEXA Value
- Changeable Data :
 - *: Serial No : Controlled / Data:01
 - ** : Month : Controlled / Data:00
 - ***:Year : Controlled
 - ****:Check sum

4.5. Auto Download

- 1) Press Adj. key on the Adj. Remote control.
- 2) Select EDID D/L menu.
- 3) By pressing Enter key, EDID download will begin
- 4) If Download is successful, OK is display, but If Download if failure, NG is displayed.
- 5) If Download is failure, Re-try downloads.

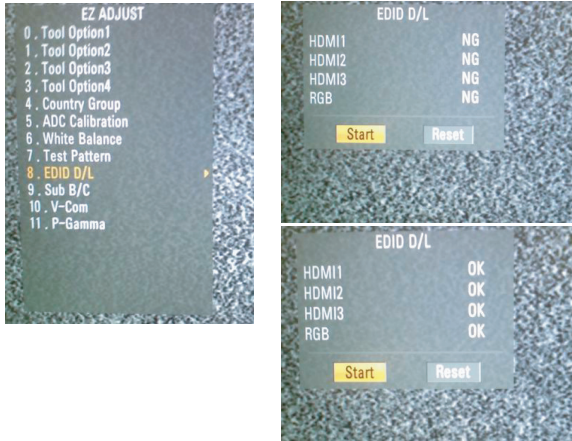

* Edid data and Model option download (RS232)

NO	Item	CMD1	CMD2	Data0	
Enter download Mode	Download 'Mode In'	A	A	0 0	When transfer the 'Mode In', Carry the command.
EDID data and Model option download	Download	A	E	00 10	Automatically Download (The use of a internal pattern)

- Manual Download

* Caution

- 1) Use the proper signal cable for EDID Download
 - Analog EDID : Pin3 exists
 - Digital EDID : Pin3 exists
- 2) Never connect HDMI & D-sub Cable at the same time.
- 3) Use the proper cables below for EDID Writing
- 4) Download HDMI1, HDMI2, separately because HDMI1 is different from HDMI2

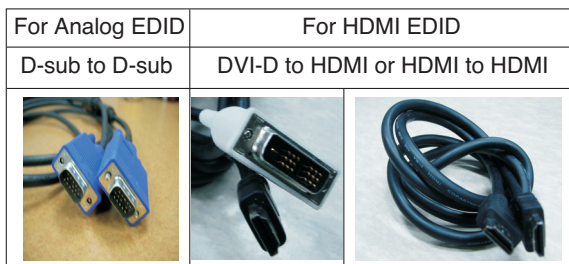

Item	Condition	Data(Hex)
Manufacturer ID	GSM	1E6D
Version	Digital : 1	01
Revision	Digital : 3	03

1) FHD RGB EDID data

	0	1	2	3	4	5	6	7	8	9	A	B	C	D	E	F	
00	00	FF	FF	FF	FF	FF	FF	00	1E	6D	a		b				
10	c	01	03	68	10	09	78	0A	EE	91	A3	54	4C	99	26		
20	0F	50	54	A1	08	00	81	80	61	40	45	40	31	40	01	01	
30	01	01	01	01	01	01	02	3A	80	18	71	38	2D	40	58	2C	
40	45	00	A0	5A	00	00	00	1E	01	1D	00	72	51	D0	1E	20	
50	6E	28	55	00	A0	5A	00	00	00	1E	00	00	00	FD	00	3A	
60	3E	1E	53	10	00	0A	20	20	20	20	20	20	d				
70	d															00	e
80	FF	FF	FF	FF	FF	FF	FF	FF	FF	FF	FF	FF	FF	FF	FF	FF	
90	FF	FF	FF	FF	FF	FF	FF	FF	FF	FF	FF	FF	FF	FF	FF	FF	
A0	FF	FF	FF	FF	FF	FF	FF	FF	FF	FF	FF	FF	FF	FF	FF	FF	
B0	FF	FF	FF	FF	FF	FF	FF	FF	FF	FF	FF	FF	FF	FF	FF	FF	
C0	FF	FF	FF	FF	FF	FF	FF	FF	FF	FF	FF	FF	FF	FF	FF	FF	
D0	FF	FF	FF	FF	FF	FF	FF	FF	FF	FF	FF	FF	FF	FF	FF	FF	
E0	FF	FF	FF	FF	FF	FF	FF	FF	FF	FF	FF	FF	FF	FF	FF	FF	
F0	FF	FF	FF	FF	FF	FF	FF	FF	FF	FF	FF	FF	FF	FF	FF	FF	

2) FHD HDMI EDID data

	0	1	2	3	4	5	6	7	8	9	A	B	C	D	E	F	
00	00	FF	FF	FF	FF	FF	FF	00	1E	6D	a		b				
10	c	01	03	80	10	09	78	0A	EE	91	A3	54	4C	99	26		
20	0F	50	54	A1	08	00	71	4F	81	01	01	01	01	01	01	01	
30	01	01	01	01	01	01	02	3A	80	18	71	38	2D	40	58	2C	
40	45	00	A0	5A	00	00	00	1E	01	1D	00	72	51	D0	1E	20	
50	6E	28	55	00	A0	5A	00	00	00	1E	00	00	00	FD	00	3A	
60	3E	1E	53	10	00	0A	20	20	20	20	20	20	d				
70	d															01	e
80	02	03	26	F1	4E	10	1F	84	13	05	14	03	02	12	20	21	
90	22	15	01	26	15	07	50	09	57	07	f						
A0	f	E3	05	03	01	01	1D	80	18	71	1C	16	20	58	2C		
B0	25	00	A0	5A	00	00	00	9E	01	1D	00	80	51	D0	0C	20	
C0	40	80	35	00	A0	5A	00	00	00	1E	02	3A	80	18	71	38	
D0	2D	40	58	2C	45	00	A0	5A	00	00	00	1E	66	21	50	B0	
E0	51	00	1B	30	40	70	36	00	A0	5A	00	00	00	1E	00	00	
F0	00	00	00	00	00	00	00	00	00	00	00	00	00	00	00	F9	

* Detail EDID Options are below
Product ID

Model Name	HEX	EDID Table	DDC Function
FHD Model	0000	01 00	Analog/Digital

Serial No: Controlled on production line.

Month, Year: Controlled on production line:

ex) Monthly : '02' -> '01'

Year : '2010' -> '14'

Model Name(Hex):

MODEL	MODEL NAME(HEX)
all	00 00 00 FC 00 4C 47 20 54 56 0A 20 20 20 20 20 20

Checksum: Changeable by total EDID data.

Vendor Specific(HDMI)

INPUT	MODEL NAME(HEX)
HDMI1	67030C001000B82D
HDMI2	67030C002000B82D
HDMI3	67030C003000B82D
HDMI4	67030C004000B82D

4.5. V-COM Adjust(Only LGD(M+S) Module)

- Why need Vcom adjustment?
- The Vcom (Common Voltage) is a Reference Voltage of Liquid Crystal Driving.
- > Liquid Crystal need for Polarity Change with every frame.

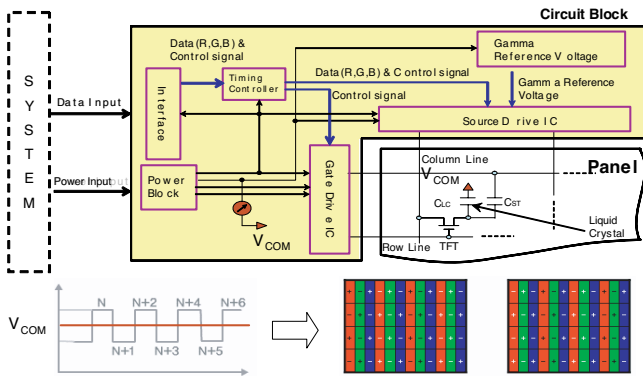

- Adjust sequence
- Press the PIP key of the ADJ remote control. (This PIP key is a hot key to enter the VCOM adjusting mode) (Or After enter Service Mode by pushing "ADJ" key, then Enter V-Com Adjust mode by pushing "▶" key at "10. V-Com")
- As pushing the right or the left key on the remote control, and find the V-COM value which is no or minimized the Flicker. (If there is no flicker at default value, Press the exit key and finish the VCOM adjustment.)
- Push the "OK" key to store value. Then the message "Saving OK" is pop.
- Press the exit key to finish VCOM adjustment.



(Visual Adjust and control the Voltage level)

4.6. Outgoing condition Configuration

- When pressing IN-STOP key by SVC remote, Red LED are blinked alternatively. And then Automatically turn off. (Must not AC power OFF during blinking)

4.7. Internal pressure

Confirm whether is normal or not when between power board's ac block and GND is impacted on 1.5 kV(dc) or 2.2 kV(dc) for one second.

5. Model name & Serial number D/L

- Press "Power on" key of service remote.
- (Baud rate : 115200 bps)
- Connect RS232 Signal Cable to RS-232 Jack.
- Write Serial number by use RS-232.
- Must check the serial number at the Diagnostics of SET UP menu. (Refer to below).

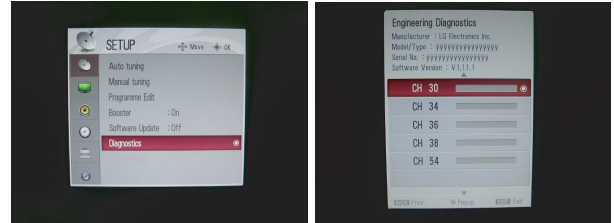

5.1. Signal TABLE

CMD	LENGTH	ADH	ADL	DATA_1	...	Data_n	CS	DELAY
-----	--------	-----	-----	--------	-----	--------	----	-------

CMD : A0h
 LENGTH : 85~94h (1~16 bytes)
 ADH : EEPROM Sub Address high (00~1F)
 ADL : EEPROM Sub Address low (00~FF)
 Data : Write data
 CS : CMD + LENGTH + ADH + ADL + Data_1 + ... + Data_n
 Delay : 20ms

5.2. Command Set

No.	Adjust mode	CMD(hex)	LENGTH(hex)	Description
1	EEPROM WRITE	A0h	84h+n	n-bytes Write (n = 1~16)

* Description
 FOS Default write : <7mode data> write
 Vtotal, V_Frequency, Sync_Polarity, Htotal, Hstart, Vstart, 0, Phase
 Data write : Model Name and Serial Number write in EEPROM,.

5.3. Method & notice

- Serial number D/L is using of scan equipment.
- Setting of scan equipment operated by Manufacturing Technology Group.
- Serial number D/L must be conformed when it is produced in production line, because serial number D/L is mandatory by D-book 4.0.

- * Manual Download (Model Name and Serial Number)
 If the TV set is downloaded by OTA or Service man, Sometimes model name or serial number is initialized. (Not always)
 There is impossible to download by bar code scan, so It need Manual download.
 - Press the 'instart' key of ADJ remote controller.
 - Go to the menu '5. Model Number D/L' like below photo.
 - Input the Factory model name(ex 42LD450-ZA) or Serial number like photo.

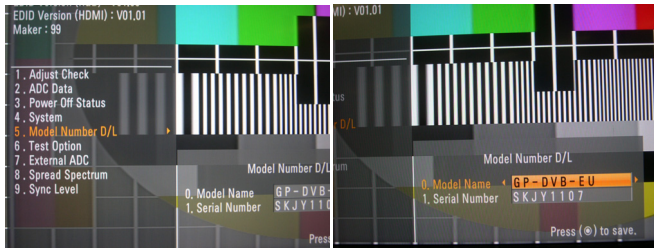

- 4) Check the model name Instart menu -> Factory name displayed (ex 42LD450-ZA)
- 5) Check the Diagnostics (DTV country only) -> Buyer model displayed (ex 42LD450)

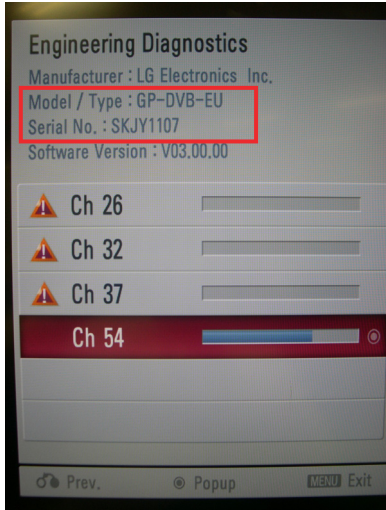

6. CI+ key download(Only for CI model)

6-1. Download Procedure

- (1) Press "Power on" button of a service R/C.(Baud rate : 115200 bps)
- (2) Connect RS232-C Signal Cable.
- (3) Write CI+ Key through RS-232-C.
- (4) Check whether the key was downloaded or not at 'In Start' menu. (Refer to below).



=> Check the Download to CI+ Key value in LGset.

6-2. check the method of CI+ Key value

- (1) Check the method on Instart menu



- (2) check the method of RS232C Command

- 1) into the main ass'y mode (RS232 : aa 00 00)

CMD 1	CMD 2	Data 0	
A	A	0	0

- 2) check the key download for transmitted command (RS232 : ci 00 10)

CMD 1	CMD 2	Data 0	
C	I	1	0

- 3) result value

- normally status for download : OKx
- abnormally status for download : NGx

6-3. Check the method of CI+ key value (RS232)

- (1) into the main ass'y mode (RS232 : aa 00 00)

CMD 1	CMD 2	Data 0	
A	A	0	0

- (2) Check the method of CI+ key by command (RS232 : ci 00 20)

CMD 1	CMD 2	Data 0	
C	I	2	0

- (3) Result value

i 01 OK 1d1852d21c1ed5dcx
 └──────────────────────────┘
 CI+ key Value

EXPLODED VIEW

IMPORTANT SAFETY NOTICE

Many electrical and mechanical parts in this chassis have special safety-related characteristics. These parts are identified by \triangle in the Schematic Diagram and EXPLODED VIEW. It is essential that these special safety parts should be replaced with the same components as recommended in this manual to prevent X-RADIATION, Shock, Fire, or other Hazards. Do not modify the original design without permission of manufacturer.

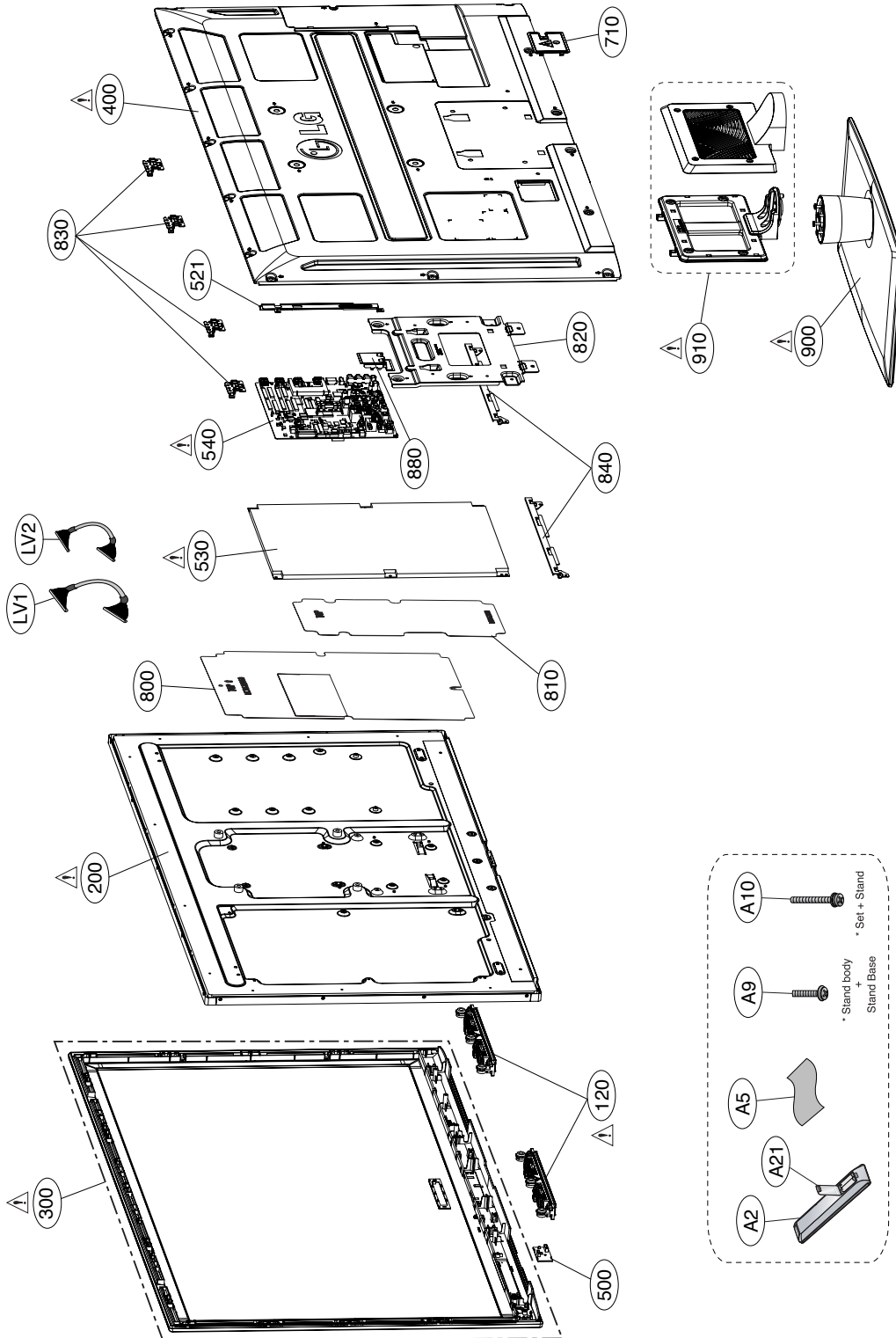

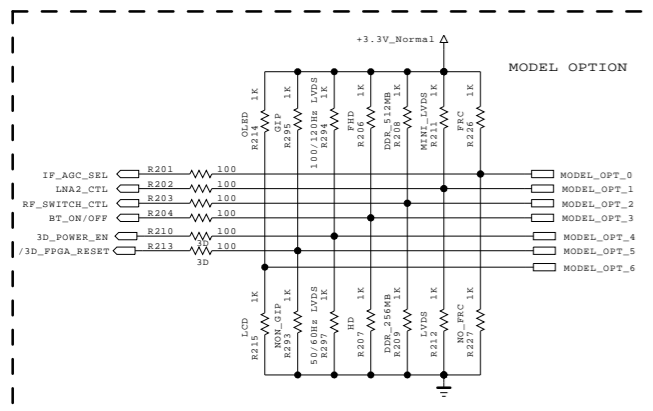

FROM LIPS & POWER B/D

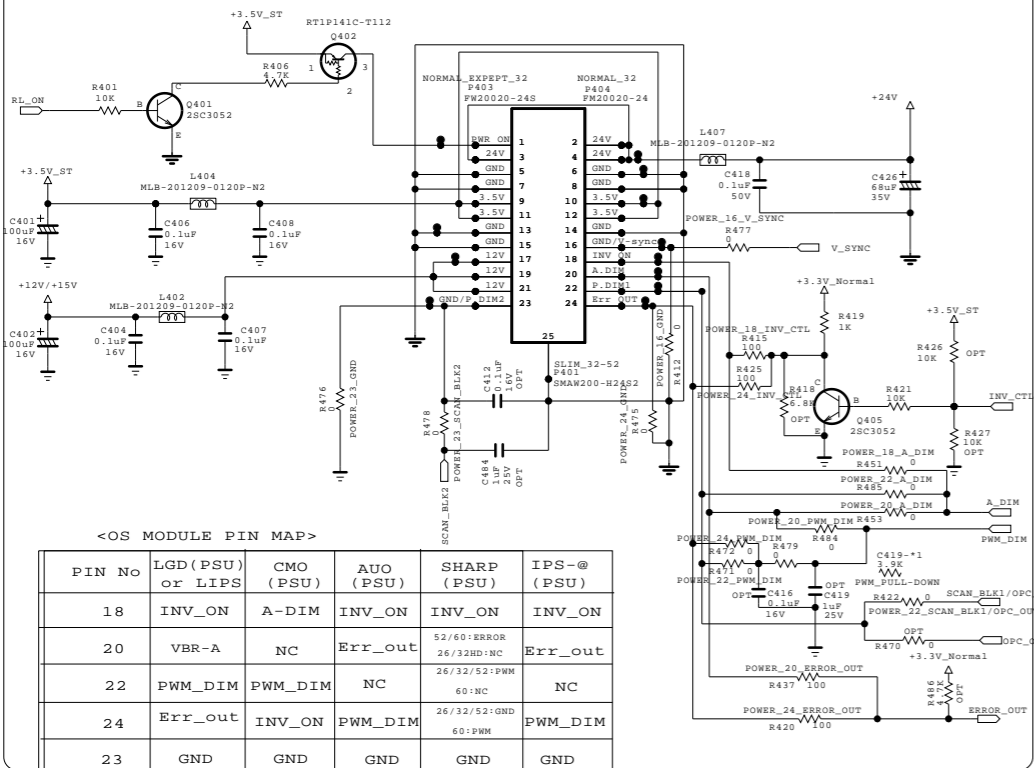

+5V_USB

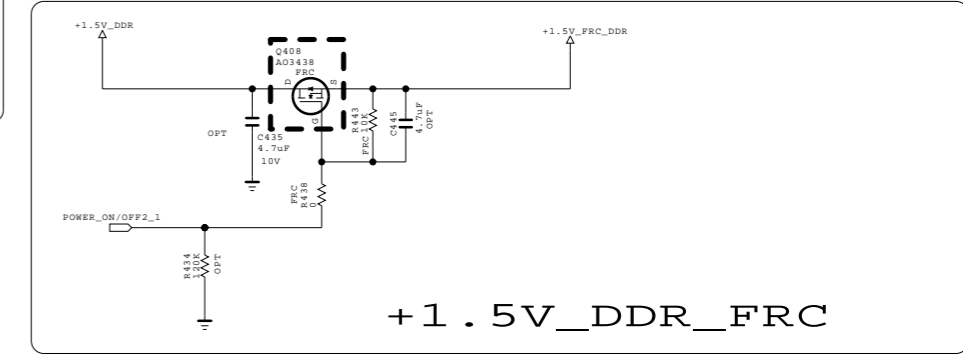
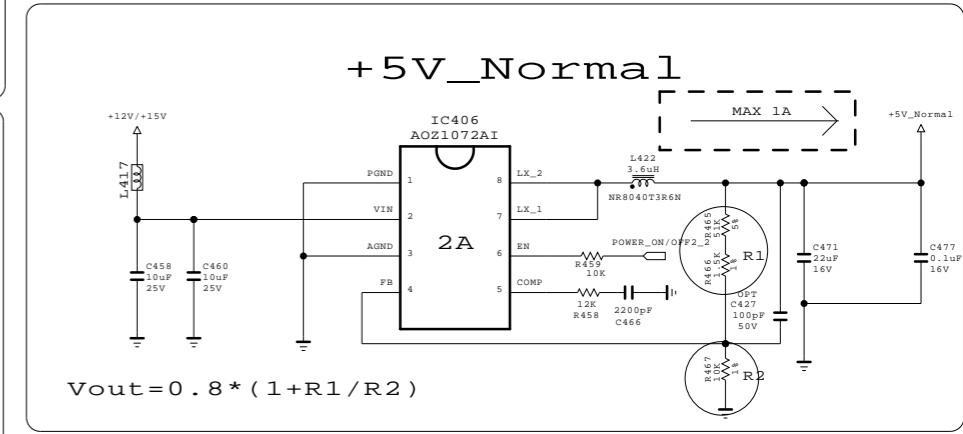
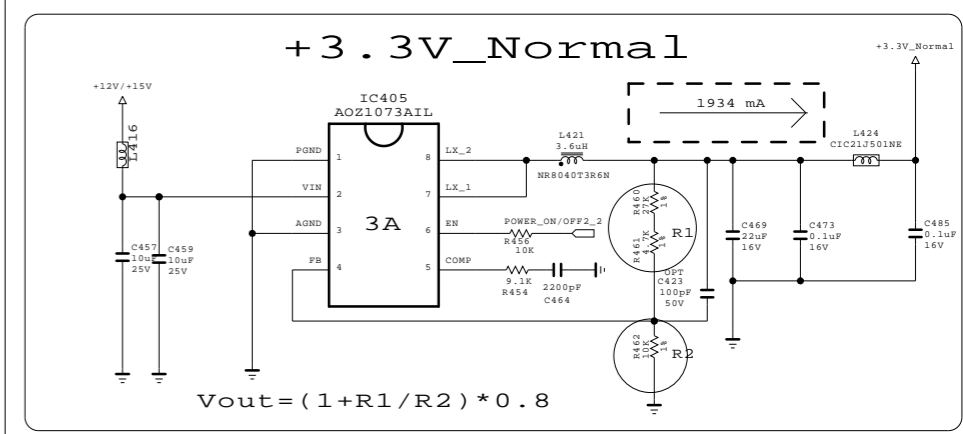
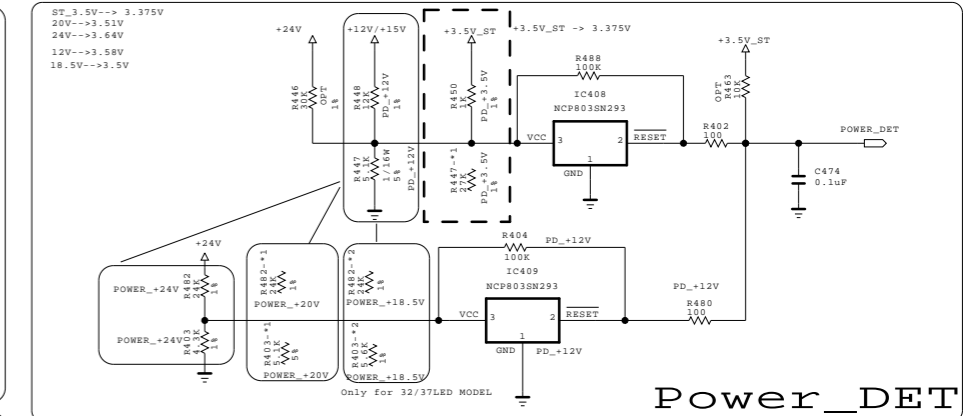
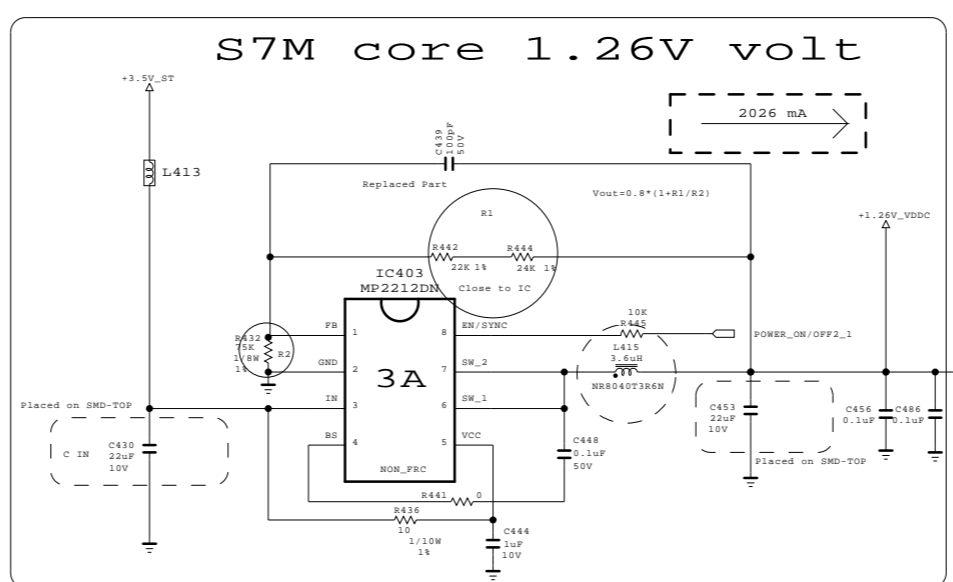
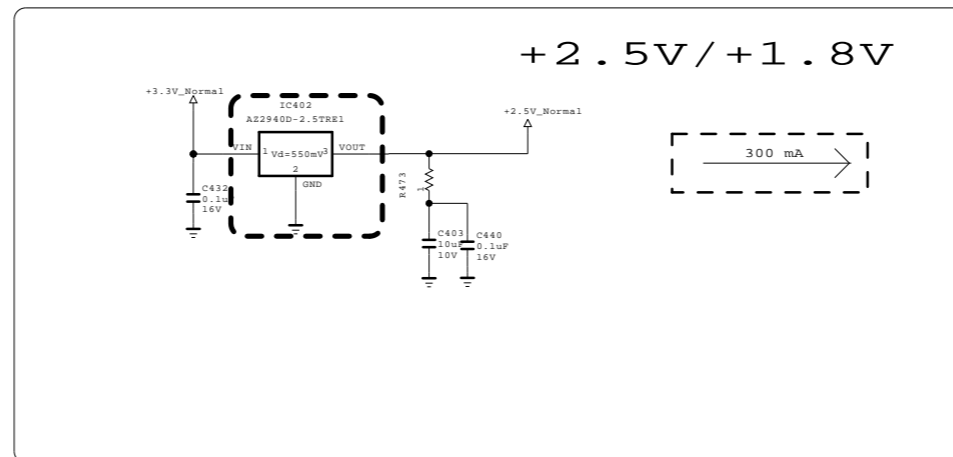
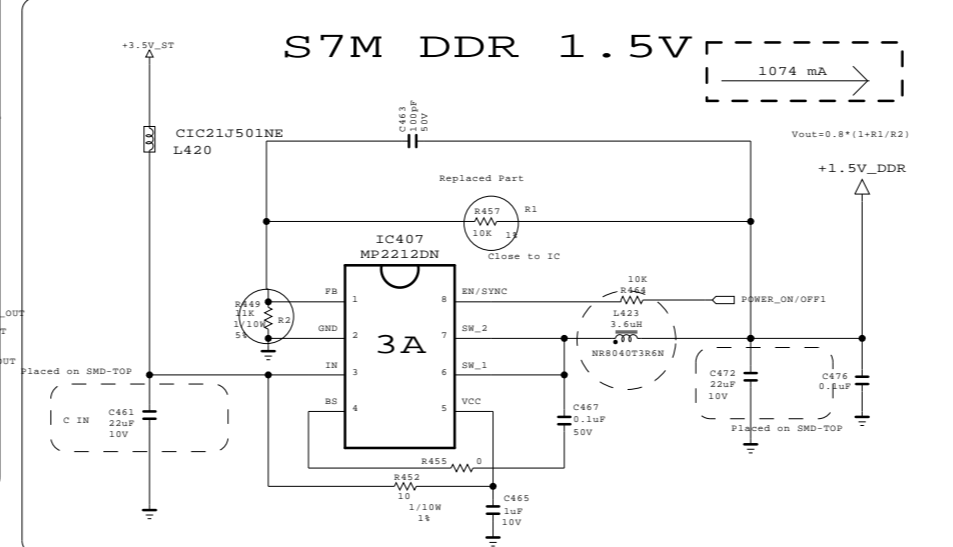
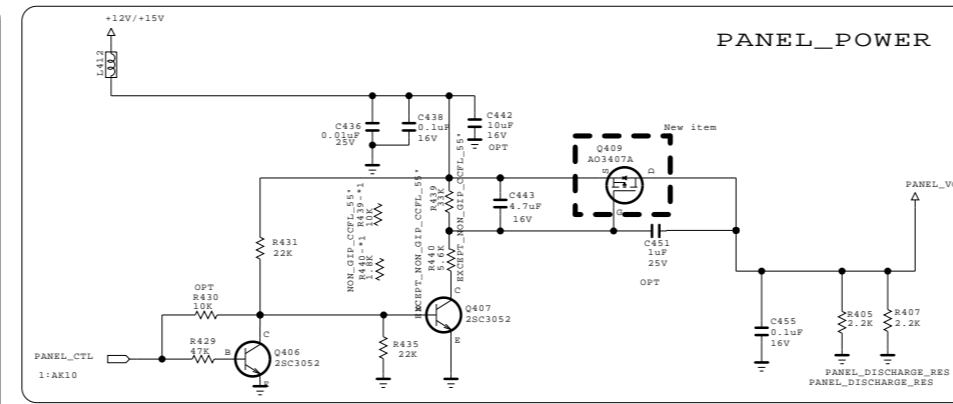
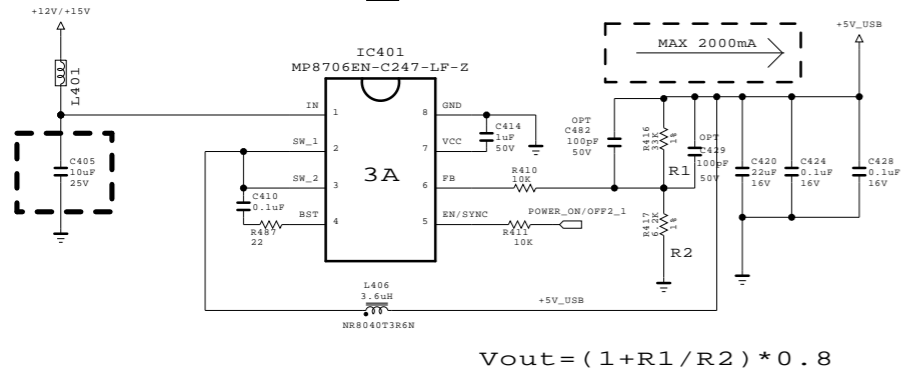

THE Δ SYMBOL MARK OF THIS SCHEMATIC DIAGRAM INCORPORATES SPECIAL FEATURES IMPORTANT FOR PROTECTION FROM X-RADIATION. FILRE AND ELECTRICAL SHOCK HAZARDS, WHEN SERVICING IF IS ESSENTIAL THAT ONLY MANUFACTURES SPECIFIED PARTS BE USED FOR THE CRITICAL COMPONENTS IN THE Δ SYMBOL MARK OF THE SCHEMATIC.

SECRET
LGElectronics



MODEL	GP2_Saturn7M	DATE	Ver. 1.2
BLOCK	POWER	SHEET	4

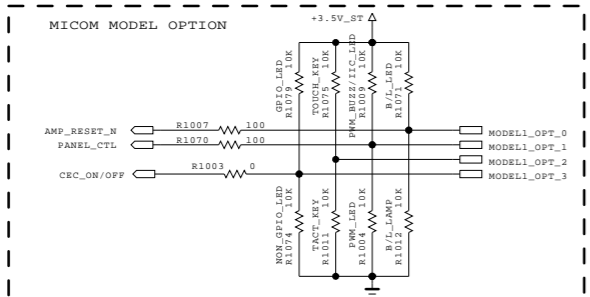
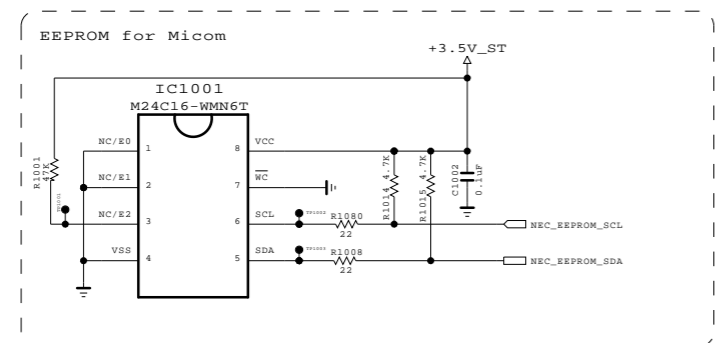
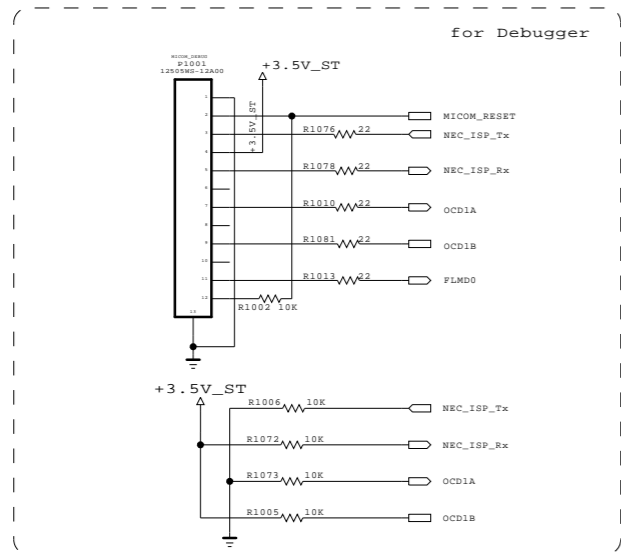

MODEL OPTION

PIN NAME	PIN NO.	HIGH	LOW
MODEL_OPT_0	8	B/L_LED	B/L_LAMP
MODEL_OPT_1	11	PWM_BUZZ/IIC_LED	PWM_LED
MODEL_OPT_2	30	TOUCH_KEY	TACT_KEY
MODEL_OPT_3	31	GPIO_LED	NON_GPIO_LED

MODEL_OPT_0	MODEL_OPT_1	MODEL_OPT_2	MODEL_OPT_3	
LOW	LOW	LOW	LOW	LD350/450/550
HIGH	LOW	HIGH	LOW	19/22/26LE3300(5500)
HIGH	HIGH	HIGH	LOW	32/37/42/47/55LRS300(10)
LOW	HIGH	LOW	LOW	LD420
HIGH	LOW	LOW	HIGH	LK7300
	HIGH		HIGH	TBD

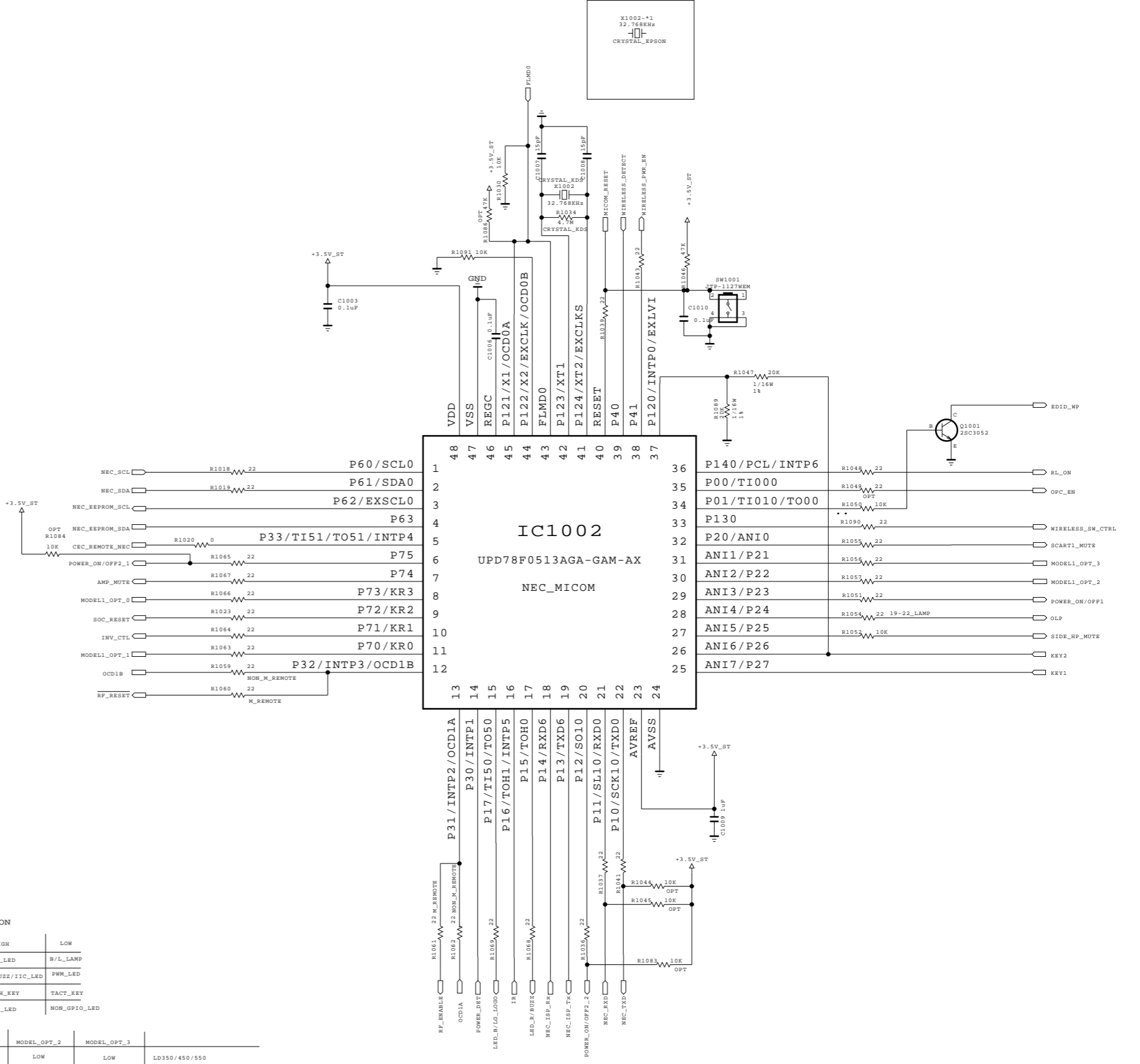

THE SYMBOL MARK OF THIS SCHEMATIC DIAGRAM INCORPORATES SPECIAL FEATURES IMPORTANT FOR PROTECTION FROM X-RADIATION. FILRE AND ELECTRICAL SHOCK HAZARDS, WHEN SERVICING IF IS ESSENTIAL THAT ONLY MANUFACTURES SPECIFIED PARTS BE USED FOR THE CRITICAL COMPONENTS IN THE SYMBOL MARK OF THE SCHEMATIC.

SECRET
LGElectronics



MODEL	GP2_Saturn7M	DATE	Ver. 1.4
BLOCK	MICOM	SHEET	5

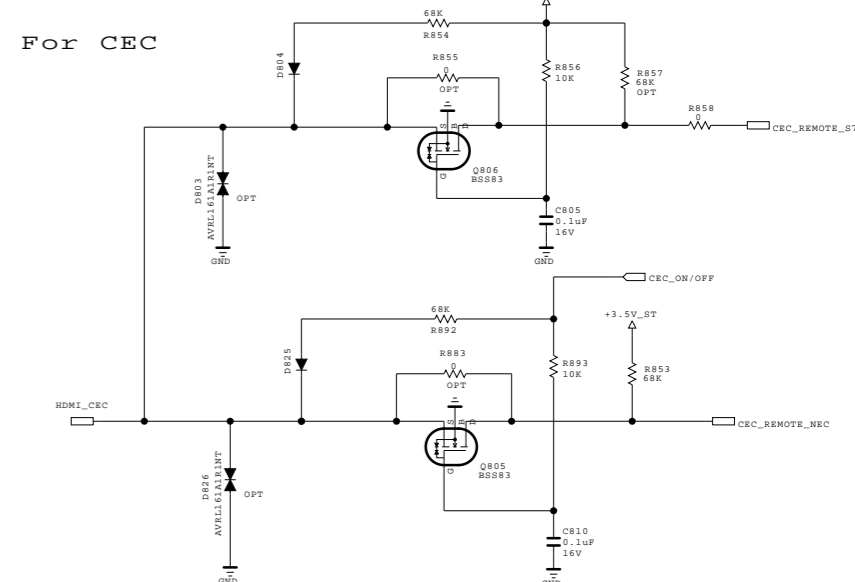
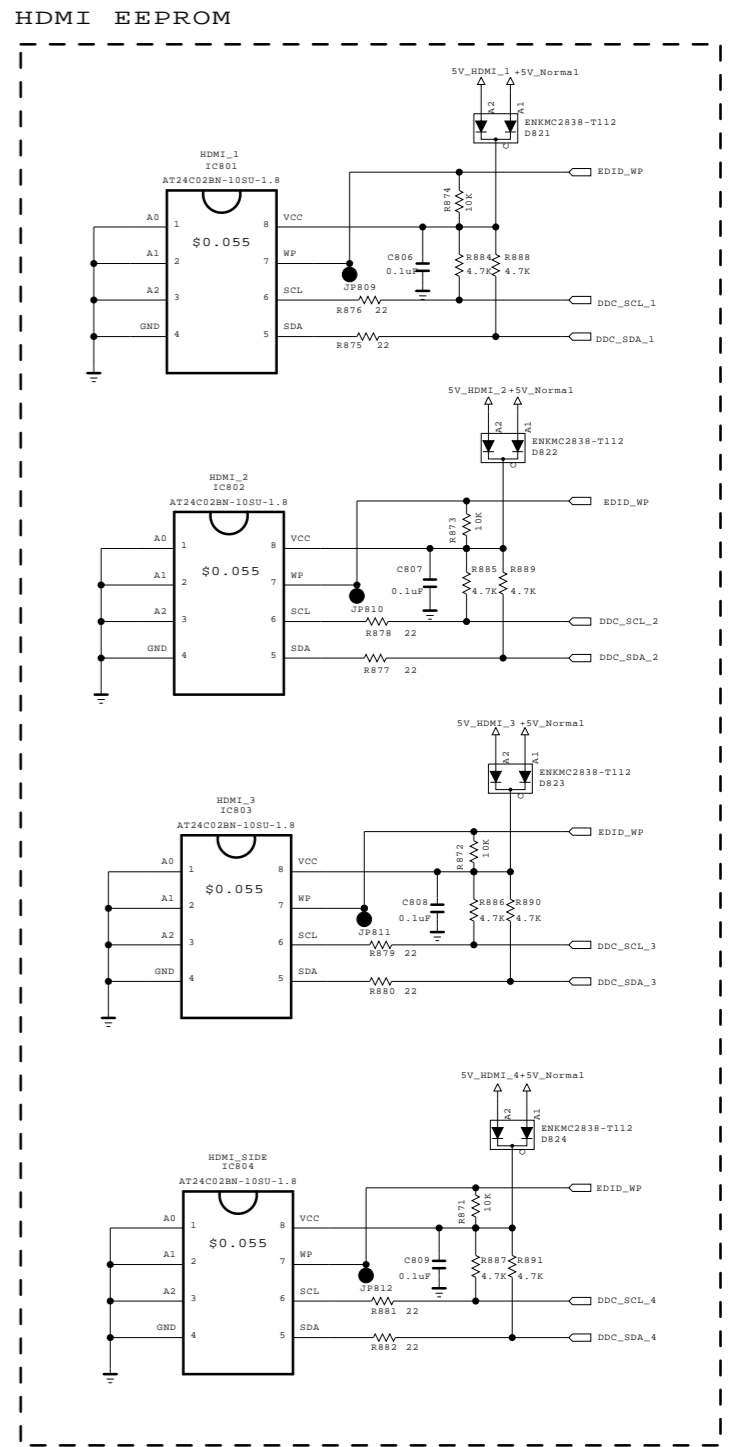
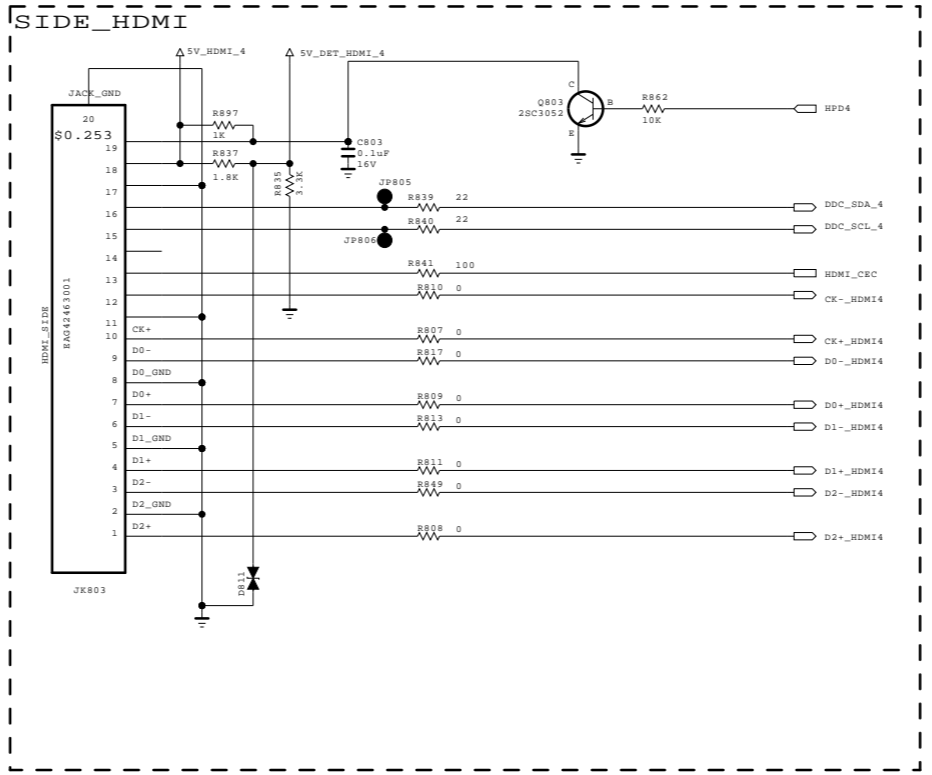
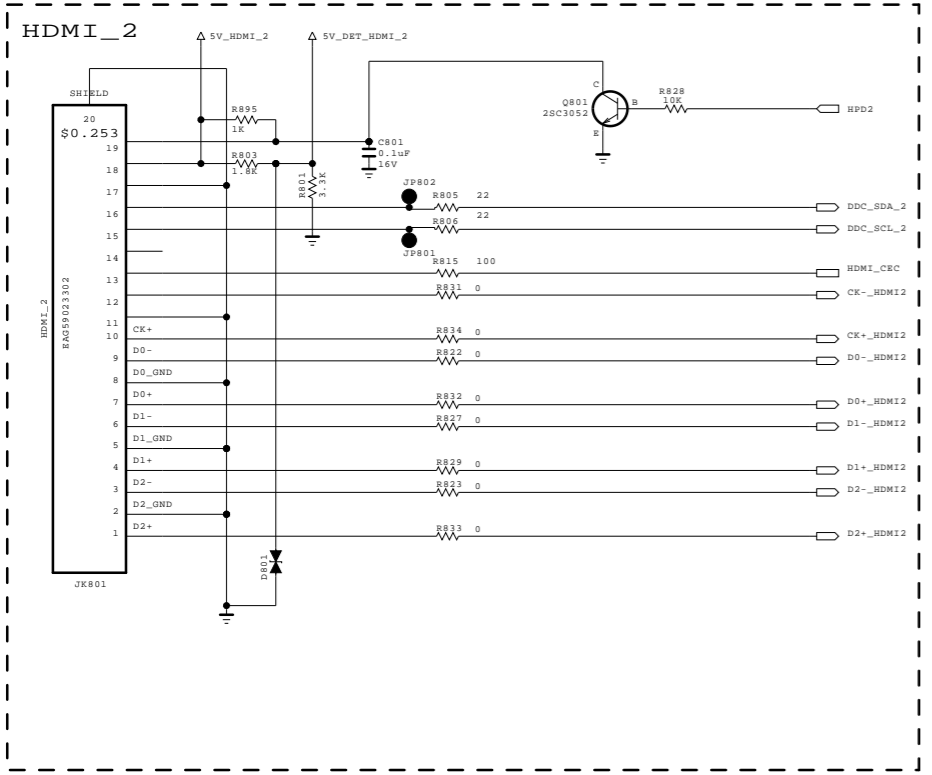
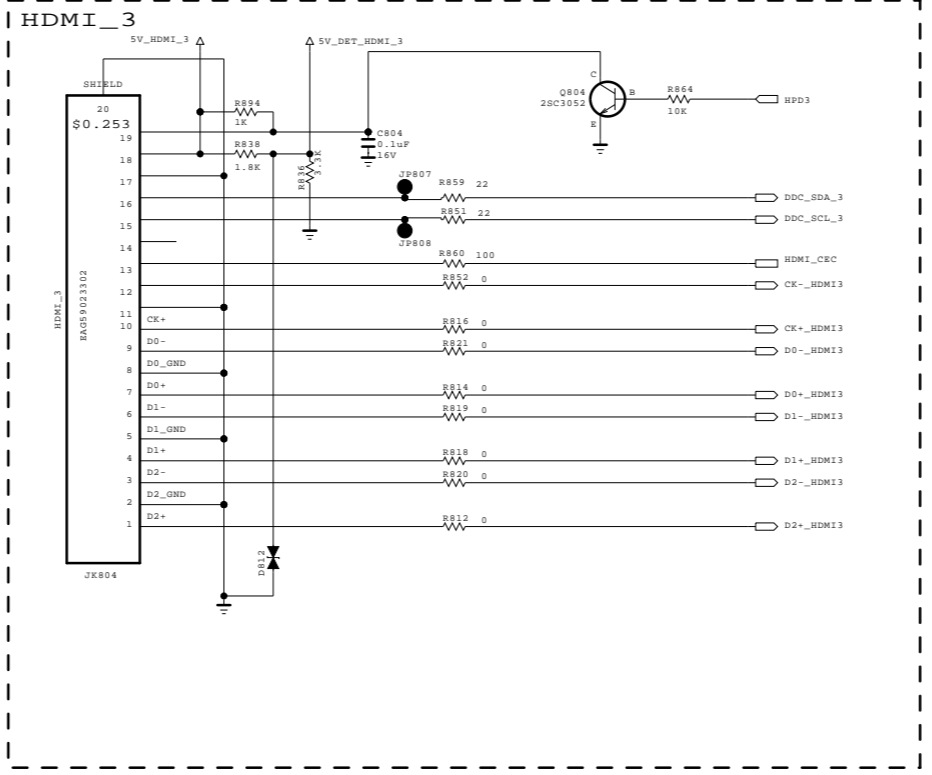
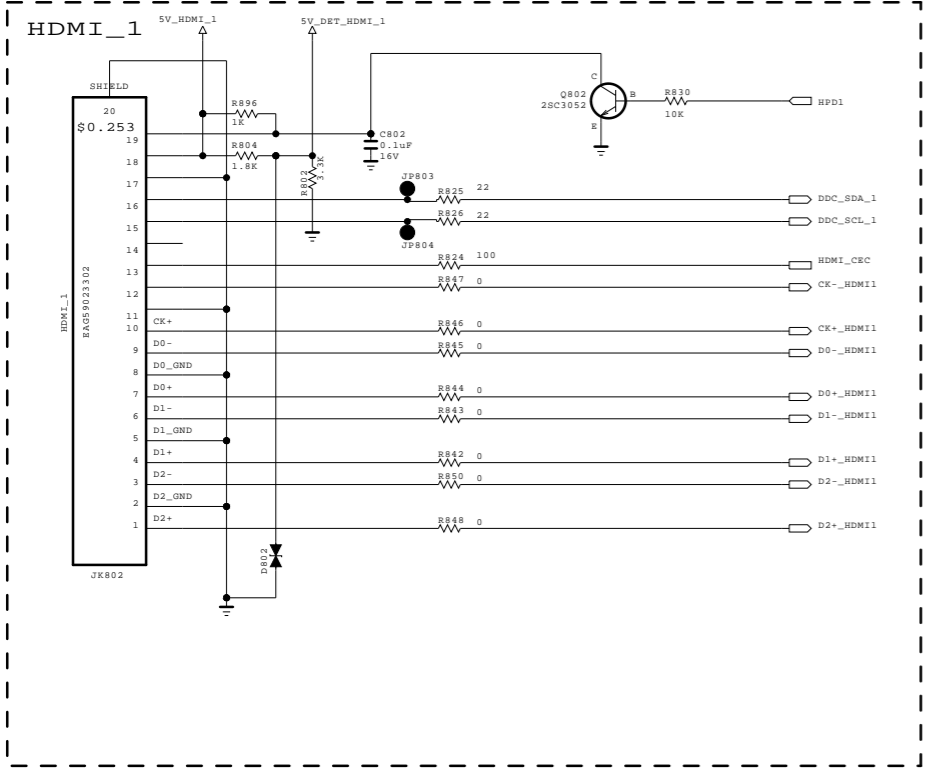

THE Δ SYMBOL MARK OF THIS SCHEMATIC DIAGRAM INCORPORATES SPECIAL FEATURES IMPORTANT FOR PROTECTION FROM X-RADIATION. FILRE AND ELECTRICAL SHOCK HAZARDS, WHEN SERVICING IF IS ESSENTIAL THAT ONLY MANUFACTURES SPECIFIED PARTS BE USED FOR THE CRITICAL COMPONENTS IN THE Δ SYMBOL MARK OF THE SCHEMATIC.

SECRET
LGElectronics



MODEL	GP2_Saturn7M	DATE	Ver. 1.2
BLOCK	HDMI	SHEET	8

COMMON AREA

New Item Development EARPHONE BLOCK

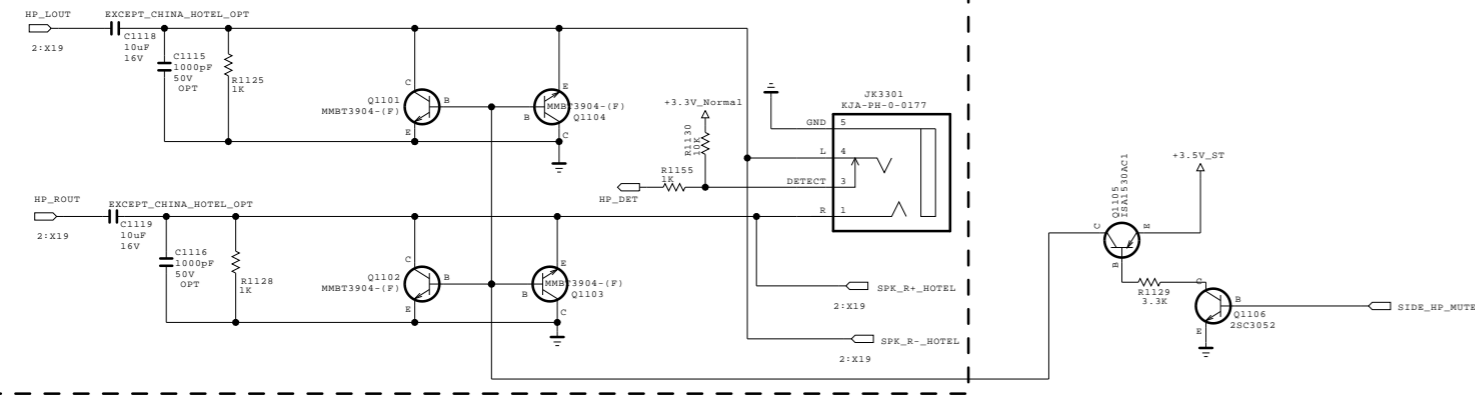

PC AUDIO

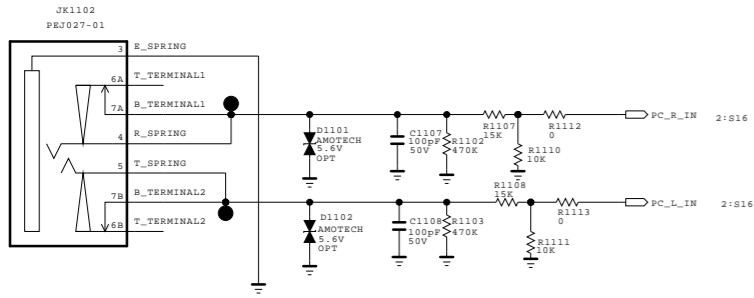

SPDIF OPTIC JACK

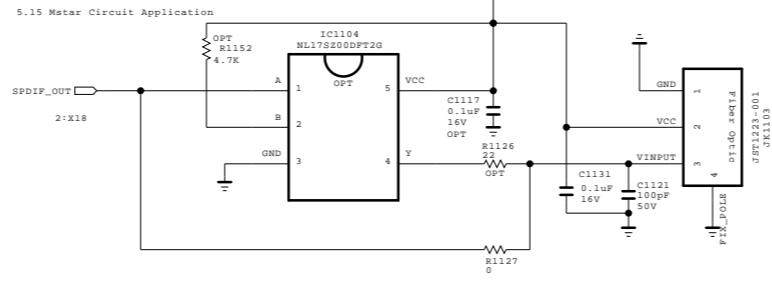

RGB PC

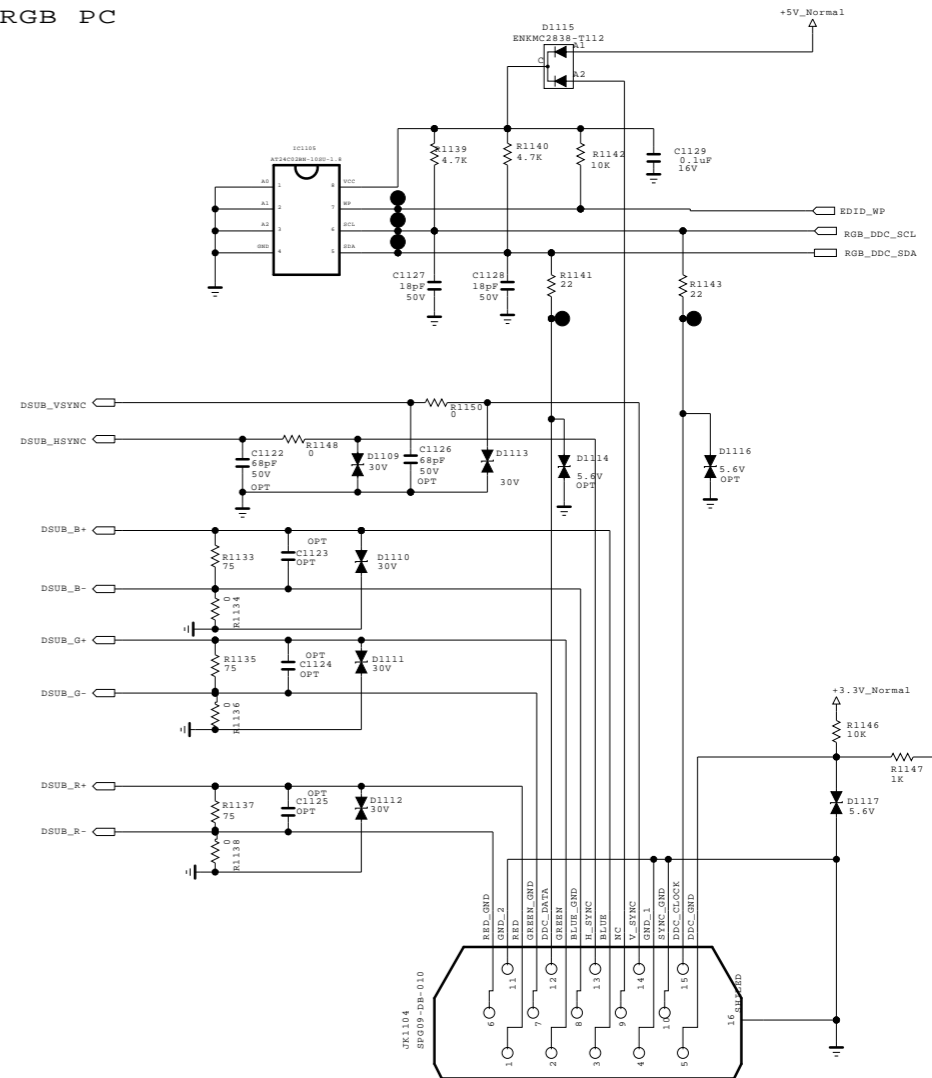

THE SYMBOL MARK OF THIS SCHEMATIC DIAGRAM INCORPORATES SPECIAL FEATURES IMPORTANT FOR PROTECTION FROM X-RADIATION. FILRE AND ELECTRICAL SHOCK HAZARDS, WHEN SERVICING IF IS ESSENTIAL THAT ONLY MANUFACTURES SPECIFIED PARTS BE USED FOR THE CRITICAL COMPONENTS IN THE SYMBOL MARK OF THE SCHEMATIC.

SECRET
LGElectronics



MODEL	GP2_Saturn7M	DATE	Ver. 1.0
BLOCK	COMMON AREA	SHEET	9 /

RS232C

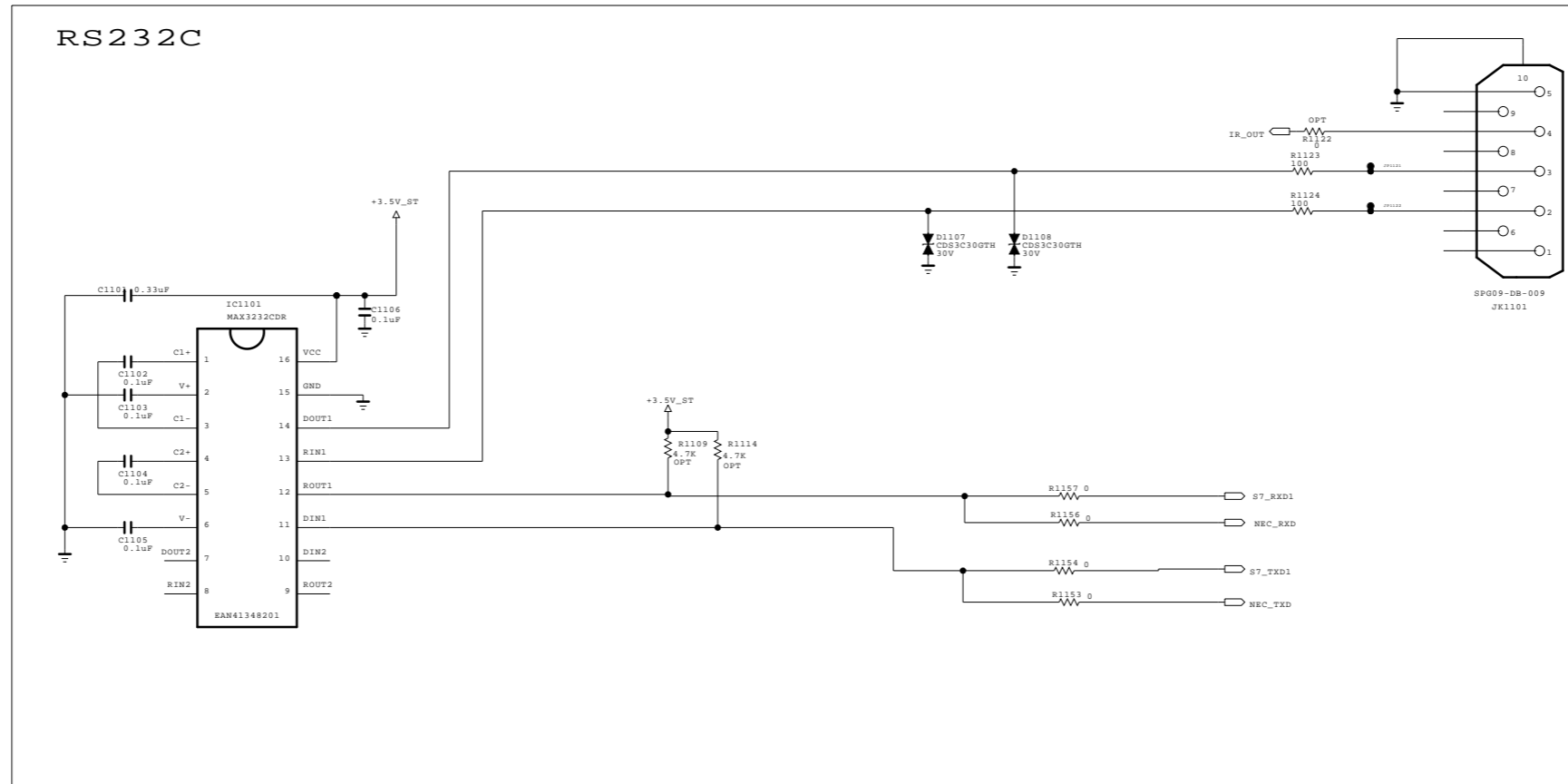

THE SYMBOL MARK OF THIS SCHEMATIC DIAGRAM INCORPORATES SPECIAL FEATURES IMPORTANT FOR PROTECTION FROM X-RADIATION. FILRE AND ELECTRICAL SHOCK HAZARDS, WHEN SERVICING IF IS ESSENTIAL THAT ONLY MANUFACTURES SPECIFIED PARTS BE USED FOR THE CRITICAL COMPONENTS IN THE SYMBOL MARK OF THE SCHEMATIC.

SECRET
LGElectronics



MODEL	GP2_Saturn7M	DATE	Ver. 1.0
BLOCK	RS232C 9PIN	SHEET	10 /

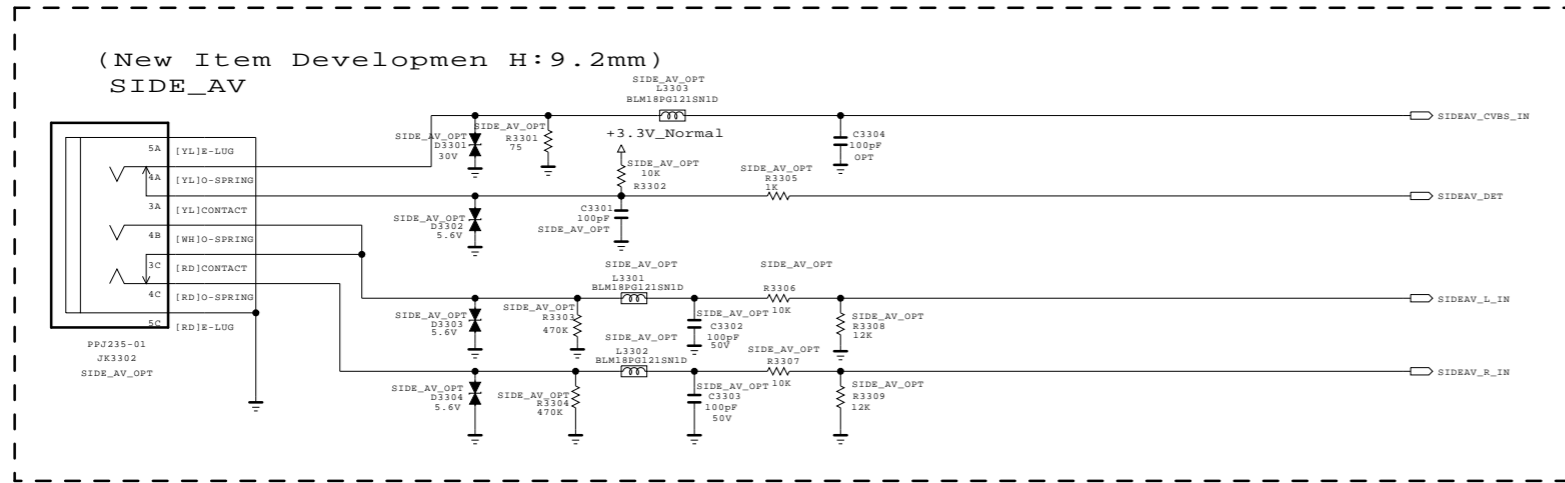

THE SYMBOL MARK OF THIS SCHEMATIC DIAGRAM INCORPORATES SPECIAL FEATURES IMPORTANT FOR PROTECTION FROM X-RADIATION. FILRE AND ELECTRICAL SHOCK HAZARDS, WHEN SERVICING IF IS ESSENTIAL THAT ONLY MANUFACTURES SPECIFIED PARTS BE USED FOR THE CRITICAL COMPONENTS IN THE SYMBOL MARK OF THE SCHEMATIC.

SECRET
LGElectronics



MODEL	GP2_Saturn7M	DATE	Ver. 1.0
BLOCK	SIDE AV	SHEET	11 /

WIRELESS READY MODEL

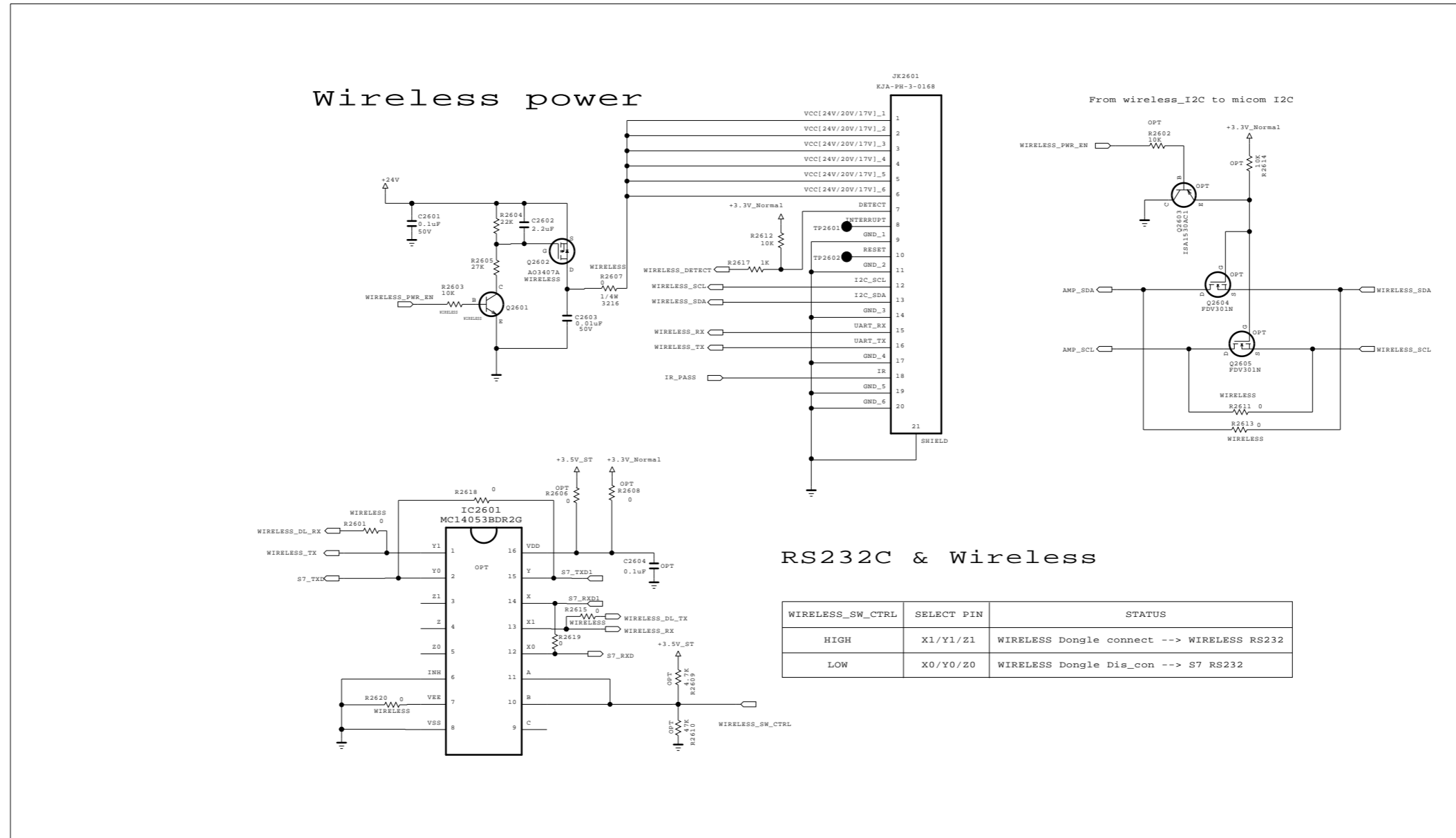

RS232C & Wireless

WIRELESS_SW_CTRL	SELECT PIN	STATUS
HIGH	X1/Y1/Z1	WIRELESS Dongle connect --> WIRELESS RS232
LOW	X0/Y0/Z0	WIRELESS Dongle Dis_con --> S7 RS232

Ver. 1.2 --> 1.3: wireless opt change, 090818, hongsu

THE SYMBOL MARK OF THIS SCHEMATIC DIAGRAM INCORPORATES SPECIAL FEATURES IMPORTANT FOR PROTECTION FROM X-RADIATION. FILRE AND ELECTRICAL SHOCK HAZARDS, WHEN SERVICING IF IS ESSENTIAL THAT ONLY MANUFACTURES SPECIFIED PARTS BE USED FOR THE CRITICAL COMPONENTS IN THE SYMBOL MARK OF THE SCHEMATIC.

SECRET
LGElectronics



MODEL	GP2_Saturn7M	DATE	Ver. 1.3
BLOCK	Wireless ready	SHEET	12 /

USB_DIODES

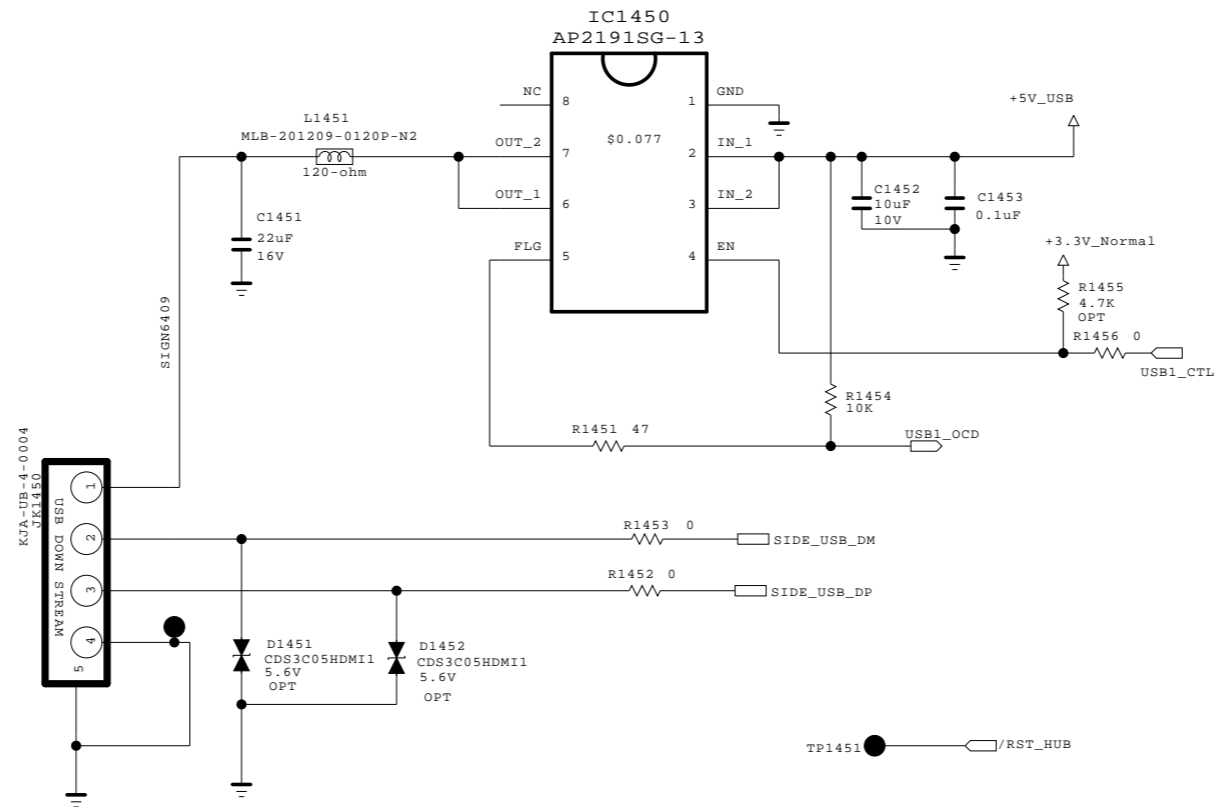

THE SYMBOL MARK OF THIS SCHEMATIC DIAGRAM INCORPORATES SPECIAL FEATURES IMPORTANT FOR PROTECTION FROM X-RADIATION, FILRE AND ELECTRICAL SHOCK HAZARDS, WHEN SERVICING IF IS ESSENTIAL THAT ONLY MANUFACTURES SPECIFIED PARTS BE USED FOR THE CRITICAL COMPONENTS IN THE SYMBOL MARK OF THE SCHEMATIC.

SECRET	
LG Electronics	

MODEL		DATE	
BLOCK		SHEET	/

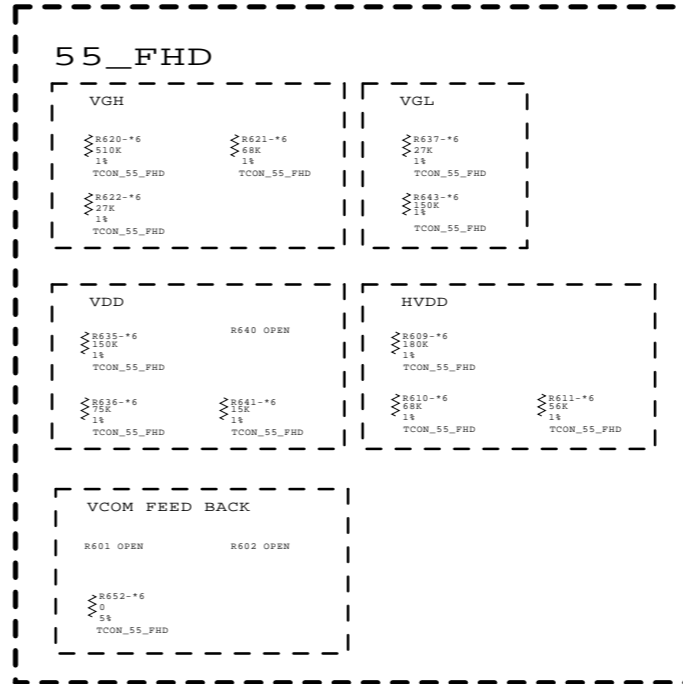
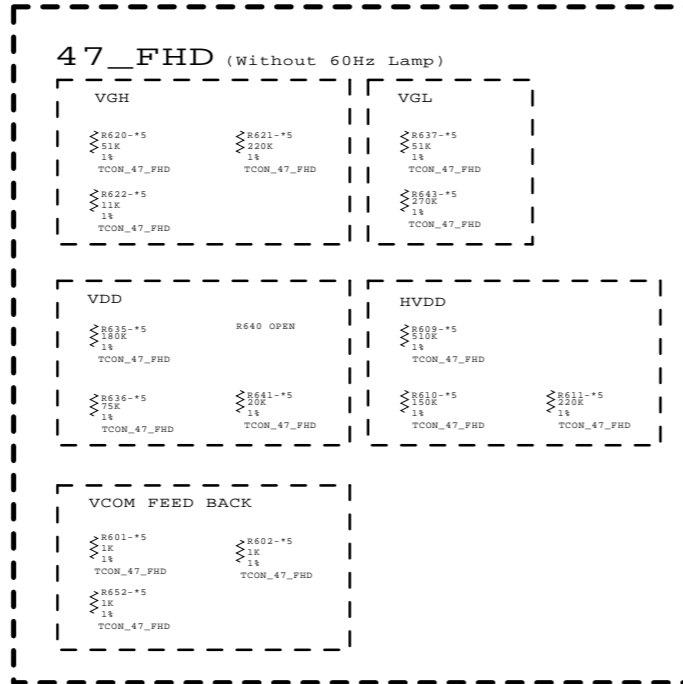
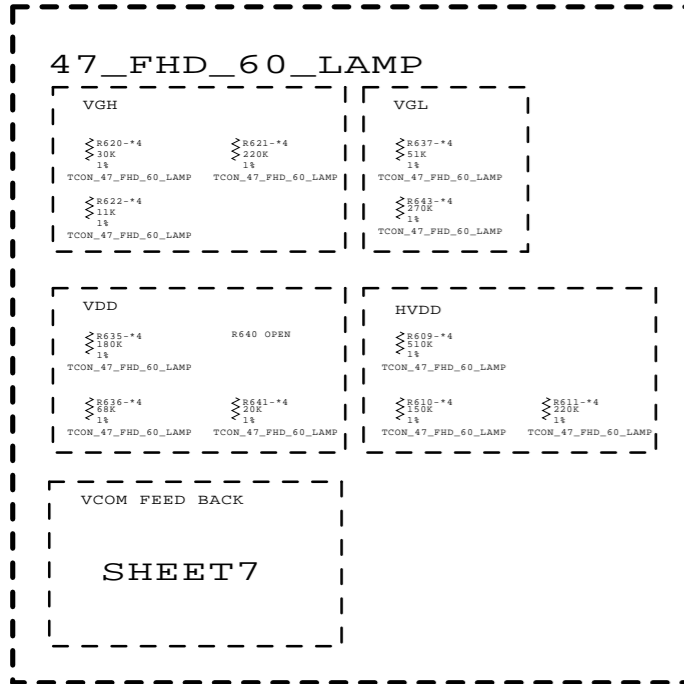
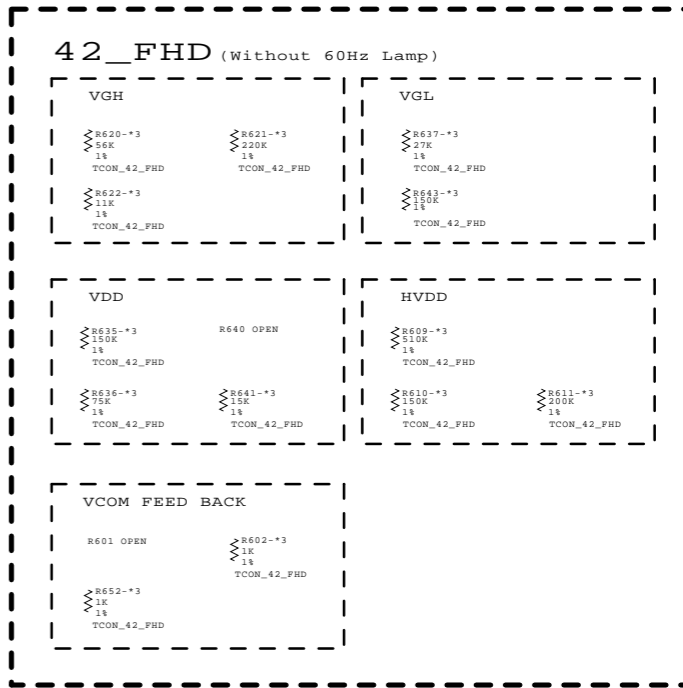
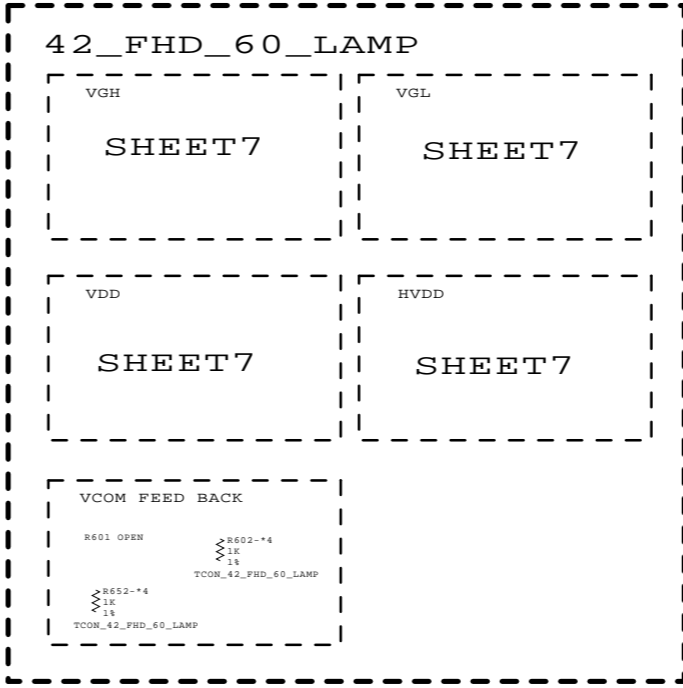
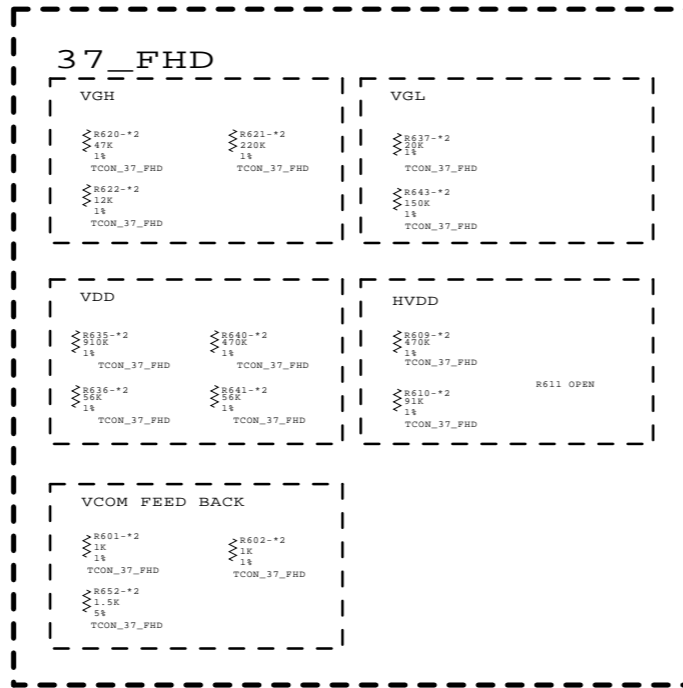
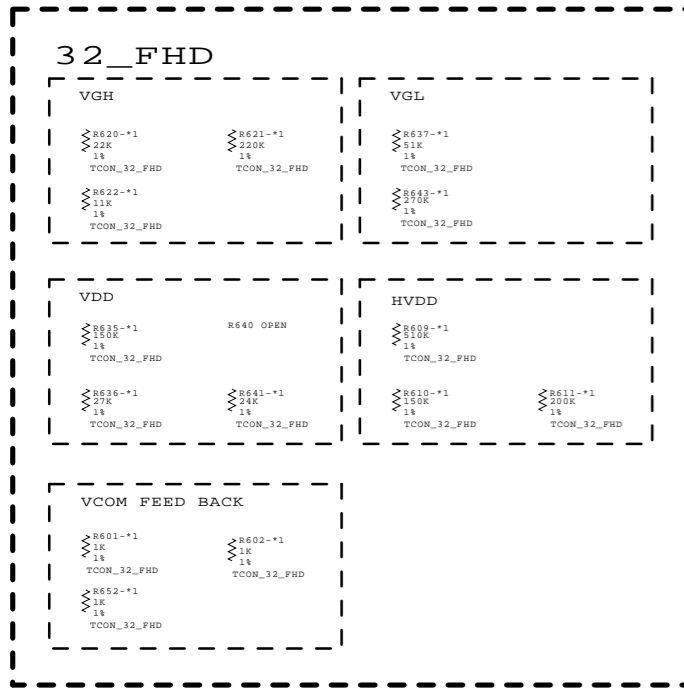



THE SYMBOL MARK OF THIS SCHEMATIC DIAGRAM INCORPORATES SPECIAL FEATURES IMPORTANT FOR PROTECTION FROM X-RADIATION. FILRE AND ELECTRICAL SHOCK HAZARDS, WHEN SERVICING IF IS ESSENTIAL THAT ONLY MANUFACTURERS SPECIFIED PARTS BE USED FOR THE CRITICAL COMPONENTS IN THE SYMBOL MARK OF THE SCHEMATIC.

SECRET
 LGElectronics

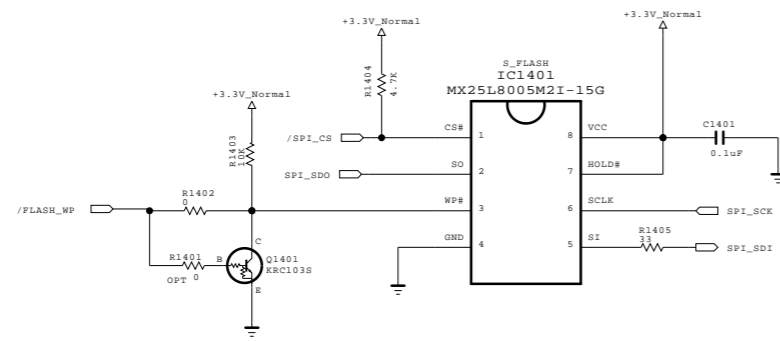

MODEL	GP2_Saturn7M	DATE	Ver. 1.2
BLOCK	T-CON Power Table	SHEET	15



THE  SYMBOL MARK OF THIS SCHEMATIC DIAGRAM INCORPORATES SPECIAL FEATURES IMPORTANT FOR PROTECTION FROM X-RADIATION. FILRE AND ELECTRICAL SHOCK HAZARDS, WHEN SERVICING IF IS ESSENTIAL THAT ONLY MANUFACTURES SPECIFIED PARTS BE USED FOR THE CRITICAL COMPONENTS IN THE  SYMBOL MARK OF THE SCHEMATIC.

SECRET
LGElectronics



MODEL	GP2_Saturn7M	DATE	Ver. 1.2
BLOCK	S-Flash(1MB)	SHEET	23 /

LGIT CAN H/N TUNER for US&KOR&BRAZIL&TAIWAN&AUS

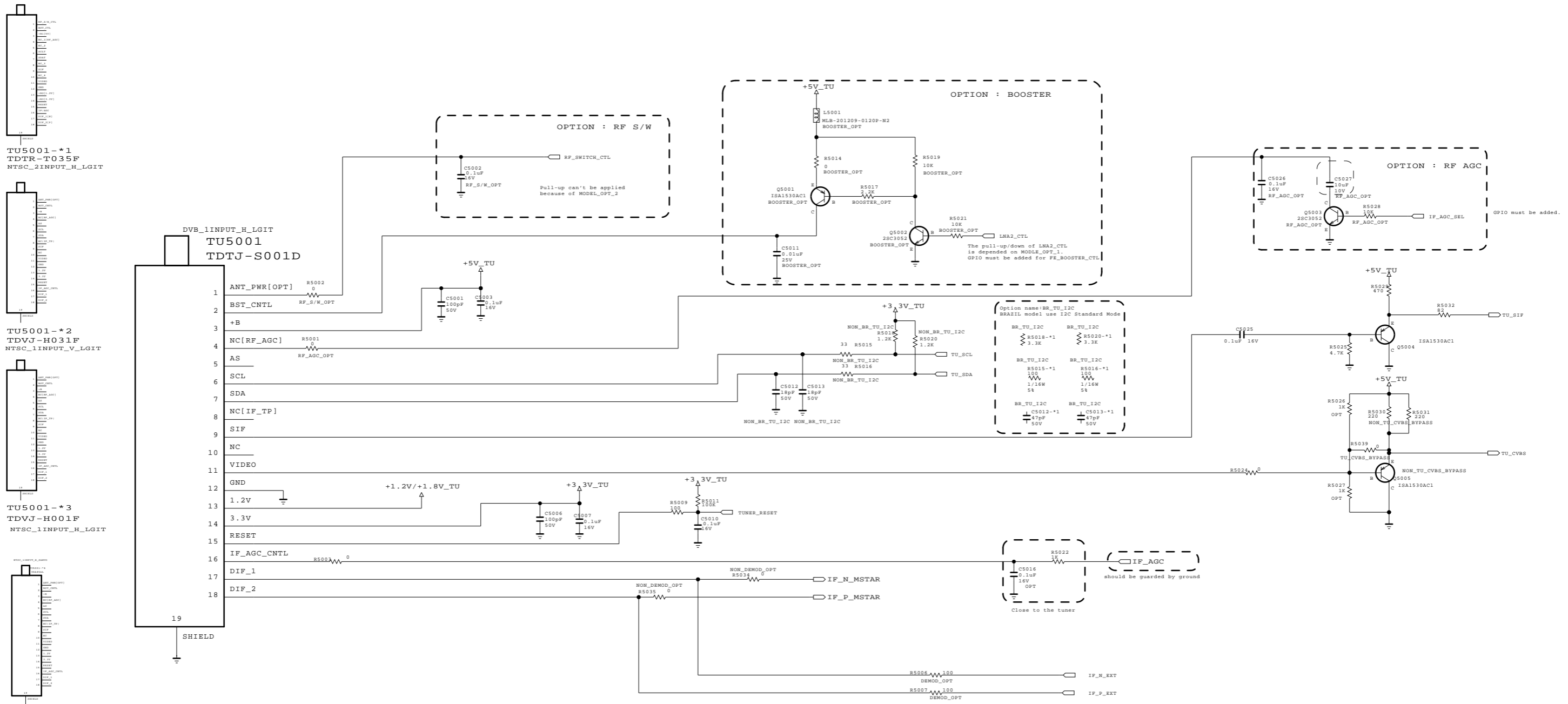

TU5001-*1
TDTR-T035F
NTSC_2INPUT_H_LGIT

TU5001-*2
TDVJ-H031F
NTSC_1INPUT_V_LGIT

TU5001-*3
TDVJ-H001F
NTSC_1INPUT_H_LGIT

*Change History.
Ver 1.0 --> 1.1: Change of chip type. 091019, w.s.jeong
Ver 1.1 --> 1.2: Change of chip type. Add of Tuner P/N for NTSC_1INPUT* 091116, w.s.jeong
1.De-rating
1) R5029, R5030, R5031 : 1005 Type => 1608 Type(w.s.jeong_1019)
2) R5030, R5031 : 200/1608 Type => 220/2012 Type(w.s.jeong_1116)
2.ADD of TUNER P/N (w.s.jeong_1116)

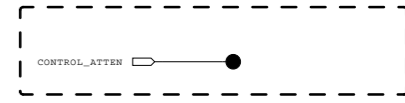
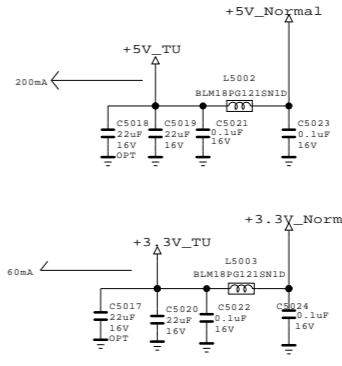
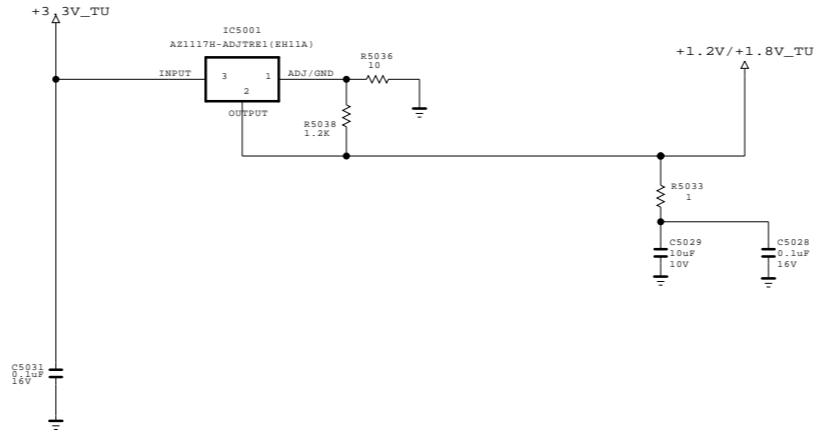

This was being applied to the only china demod, so this has to be deleted in both main and 18DB sheet.

THE Δ SYMBOL MARK OF THIS SCHEMATIC DIAGRAM INCORPORATES SPECIAL FEATURES IMPORTANT FOR PROTECTION FROM X-RADIATION. FILRE AND ELECTRICAL SHOCK HAZARDS, WHEN SERVICING IF IS ESSENTIAL THAT ONLY MANUFACTURES SPECIFIED PARTS BE USED FOR THE CRITICAL COMPONENTS IN THE Δ SYMBOL MARK OF THE SCHEMATIC.

SECRET
LGElectronics



MODEL	GP2 Saturn7M	DATE	Ver. 1.1
BLOCK	ATSC CAN TUNER	SHEET	26

Panasonic Demodulator Power (3.3V, 1.2V)

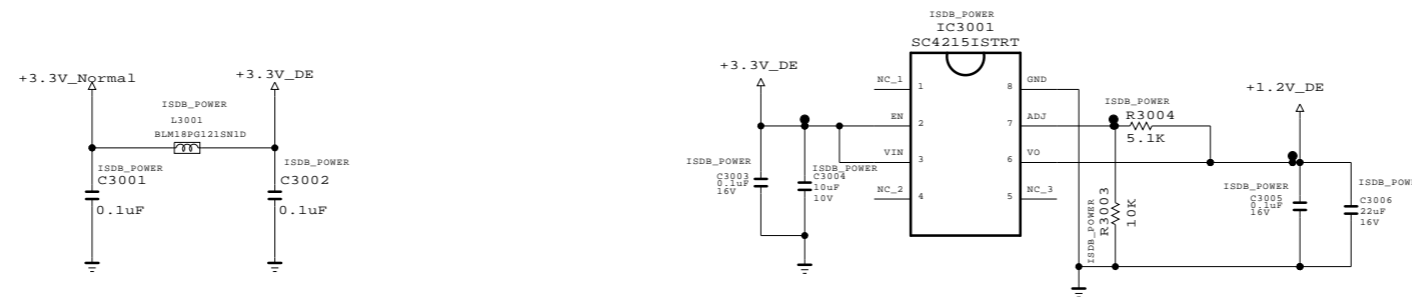

IF AGC SELECTION

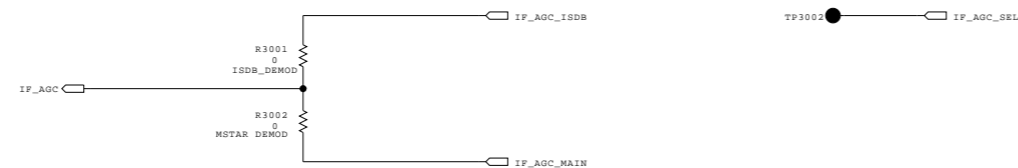

THE SYMBOL MARK OF THIS SCHEMATIC DIAGRAM INCORPORATES SPECIAL FEATURES IMPORTANT FOR PROTECTION FROM X-RADIATION. FILRE AND ELECTRICAL SHOCK HAZARDS, WHEN SERVICING IF IS ESSENTIAL THAT ONLY MANUFACTURES SPECIFIED PARTS BE USED FOR THE CRITICAL COMPONENTS IN THE SYMBOL MARK OF THE SCHEMATIC.

SECRET
LGElectronics



MODEL	GP2_Saturn7M	DATE	Ver. 1.0
BLOCK	Demodulator	SHEET	29 /

SCART OPTION BLOCK

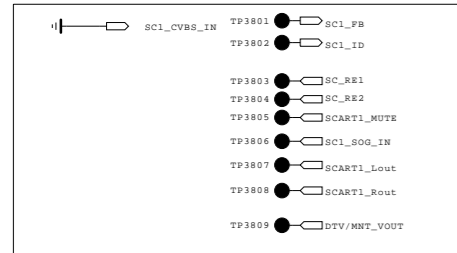

JK3801
PPJ238-01
NON CI 30

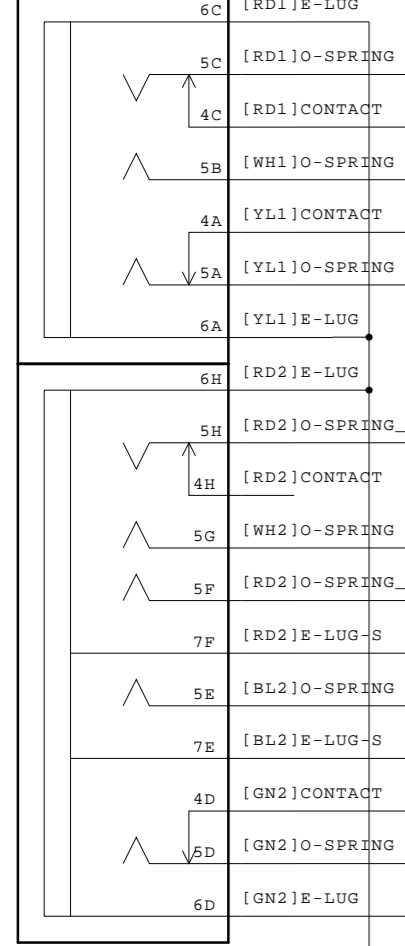

JK3802
PPJ239-01
NON CI 4/5/60

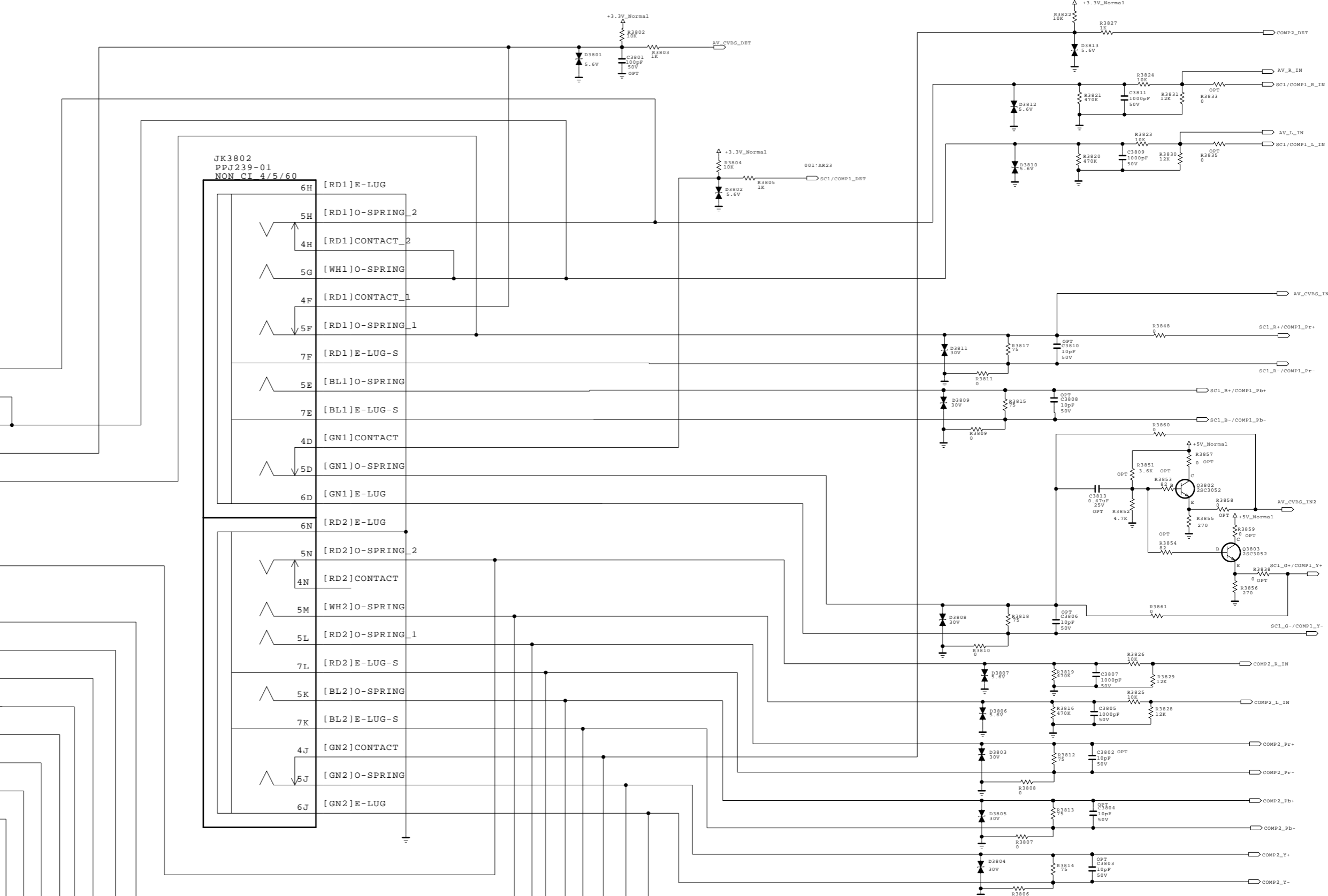
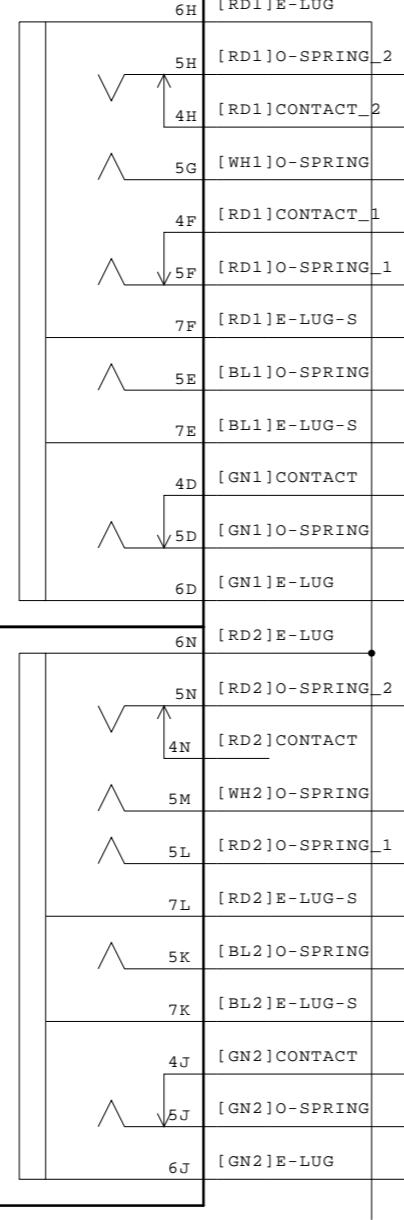

SC1/COMP1_DET	AV_CVBS_DET	RESULT
HIGH	HIGH	SC1/COMP1_DET
HIGH	LOW	SC1/COMP1_DET
LOW	HIGH	AV_CVBS_DET
LOW	LOW	

THE Δ SYMBOL MARK OF THIS SCHEMATIC DIAGRAM INCORPORATES SPECIAL FEATURES IMPORTANT FOR PROTECTION FROM X-RADIATION. FILRE AND ELECTRICAL SHOCK HAZARDS, WHEN SERVICING IF IS ESSENTIAL THAT ONLY MANUFACTURES SPECIFIED PARTS BE USED FOR THE CRITICAL COMPONENTS IN THE Δ SYMBOL MARK OF THE SCHEMATIC.

SECRET
LGElectronics



MODEL	GP2_Saturn7M	DATE	Ver. 1.1
BLOCK	NON CI LOW	SHEET	31

[LEFT FFC Connector]
(60Pin Mini-LVDS)

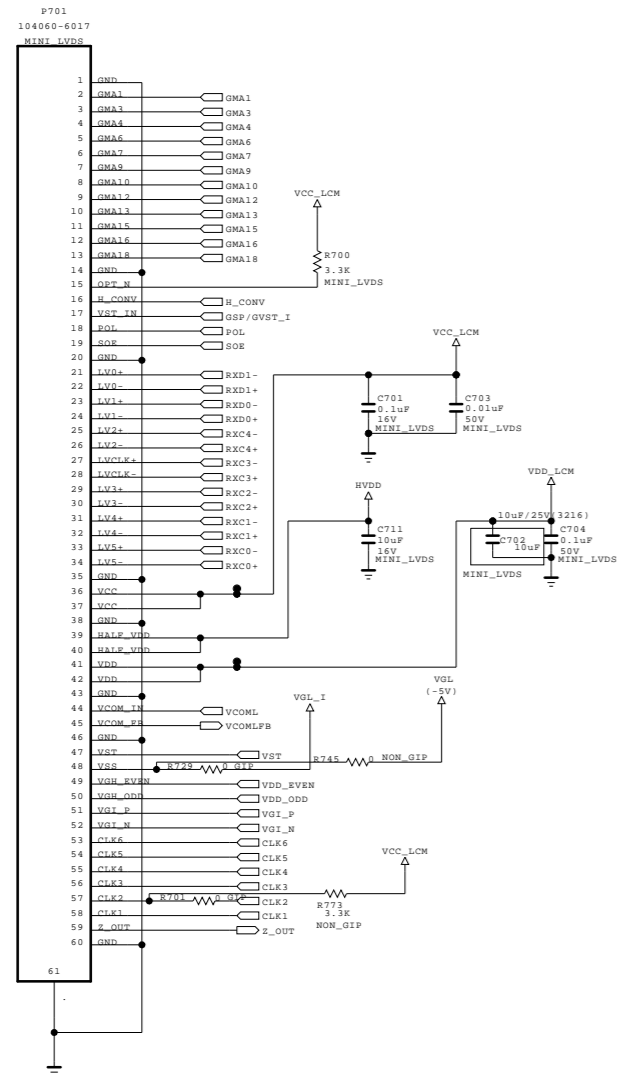

[Right FFC Connector]
(60Pin Mini-LVDS)

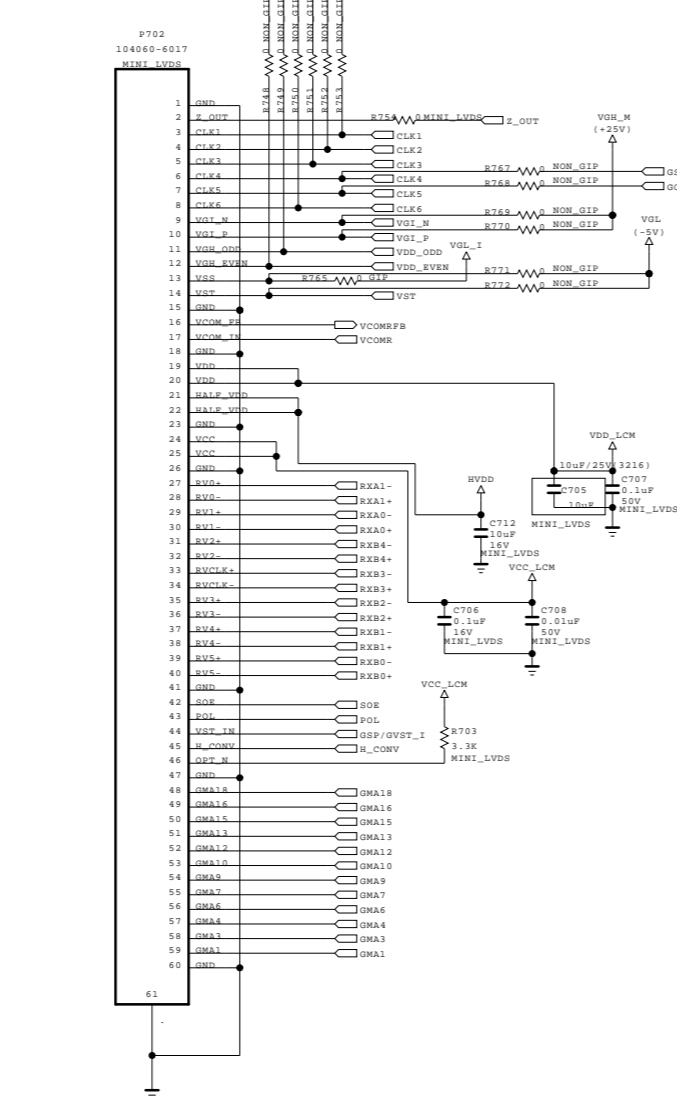

[51Pin LVDS Connector]
(For FHD 60/120Hz)

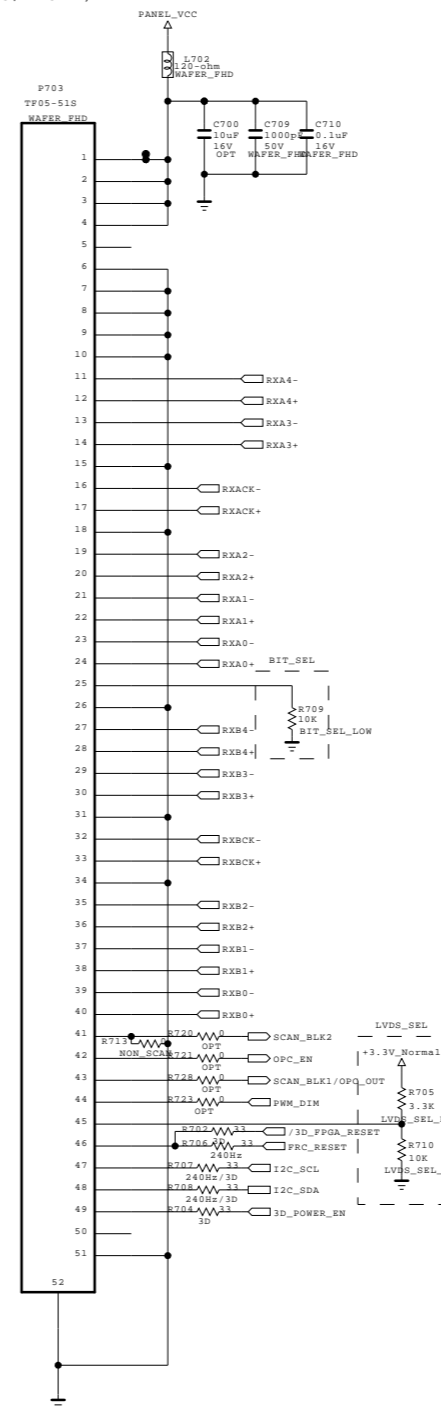

[41Pin LVDS Connector]
(For FHD 120Hz)

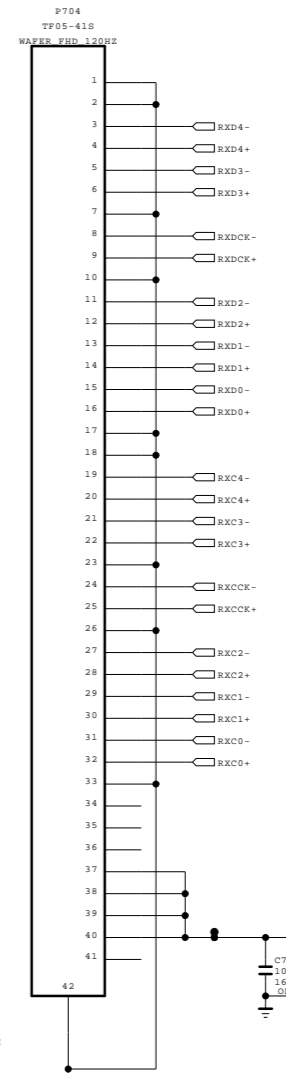

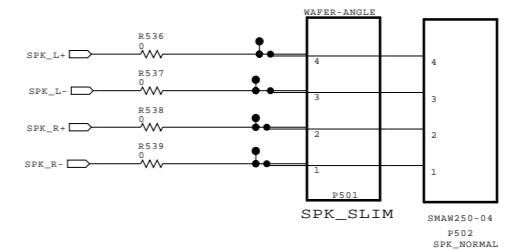
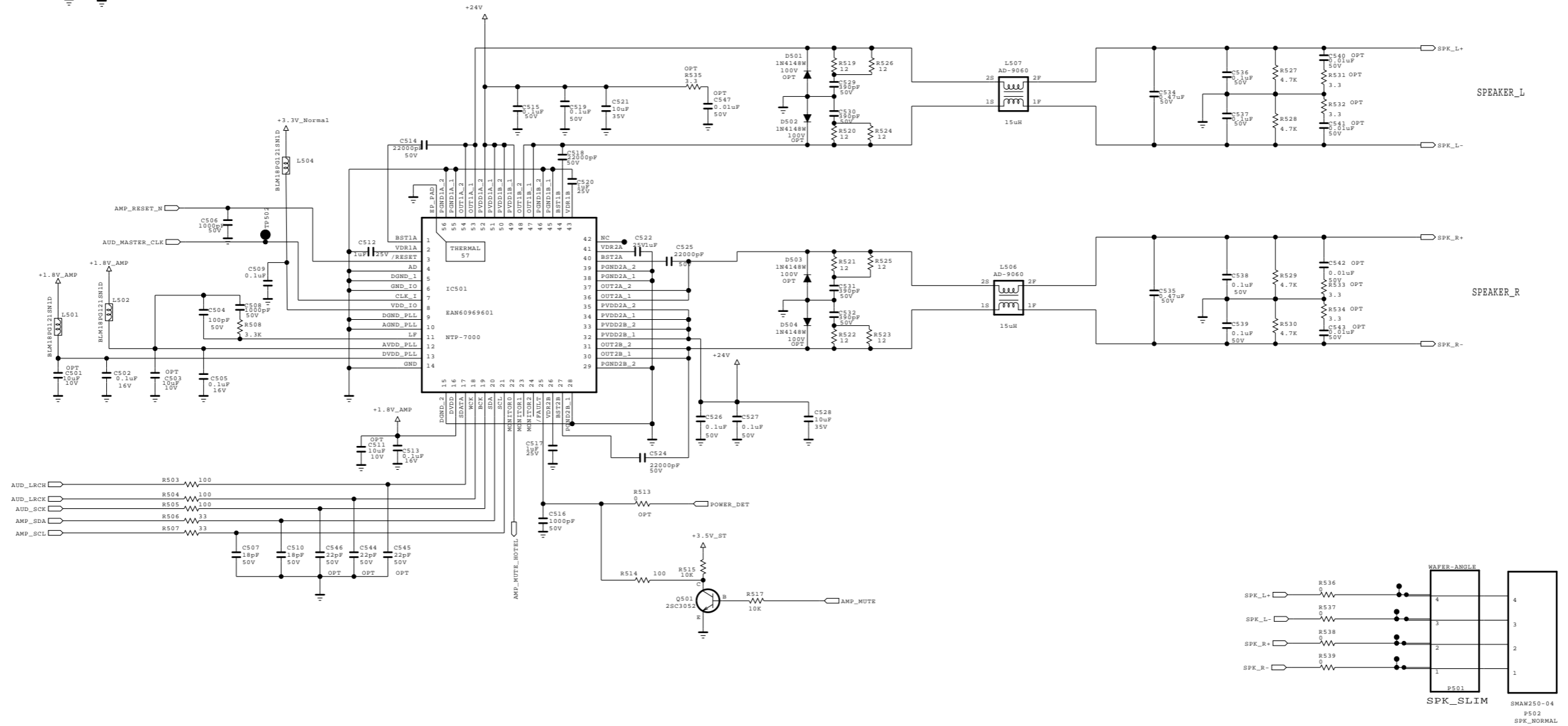
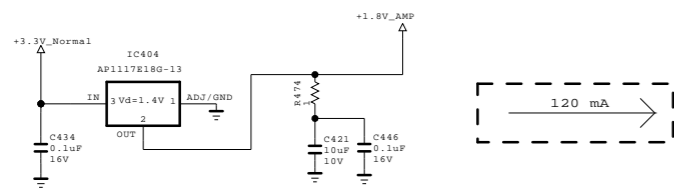

THE SYMBOL MARK OF THIS SCHEMATIC DIAGRAM INCORPORATES SPECIAL FEATURES IMPORTANT FOR PROTECTION FROM X-RADIATION. FILRE AND ELECTRICAL SHOCK HAZARDS, WHEN SERVICING IF IS ESSENTIAL THAT ONLY MANUFACTURES SPECIFIED PARTS BE USED FOR THE CRITICAL COMPONENTS IN THE SYMBOL MARK OF THE SCHEMATIC.

SECRET
LGElectronics



MODEL	GP2_Saturn7M	DATE	Ver. 1.1
BLOCK	AUDIO [NTP]	SHEET	38 /

NOT USING B/T

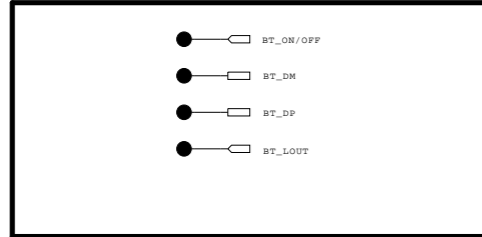

THE SYMBOL MARK OF THIS SCHEMATIC DIAGRAM INCORPORATES SPECIAL FEATURES IMPORTANT FOR PROTECTION FROM X-RADIATION. FILRE AND ELECTRICAL SHOCK HAZARDS, WHEN SERVICING IF IS ESSENTIAL THAT ONLY MANUFATURES SPECIFIED PARTS BE USED FOR THE CRITICAL COMPONENTS IN THE SYMBOL MARK OF THE SCHEMATIC.

SECRET
LGElectronics



MODEL	GP2_Saturn7M	DATE	Ver. 1.0
BLOCK	NON B/T	SHEET	44 /

NON CI Region

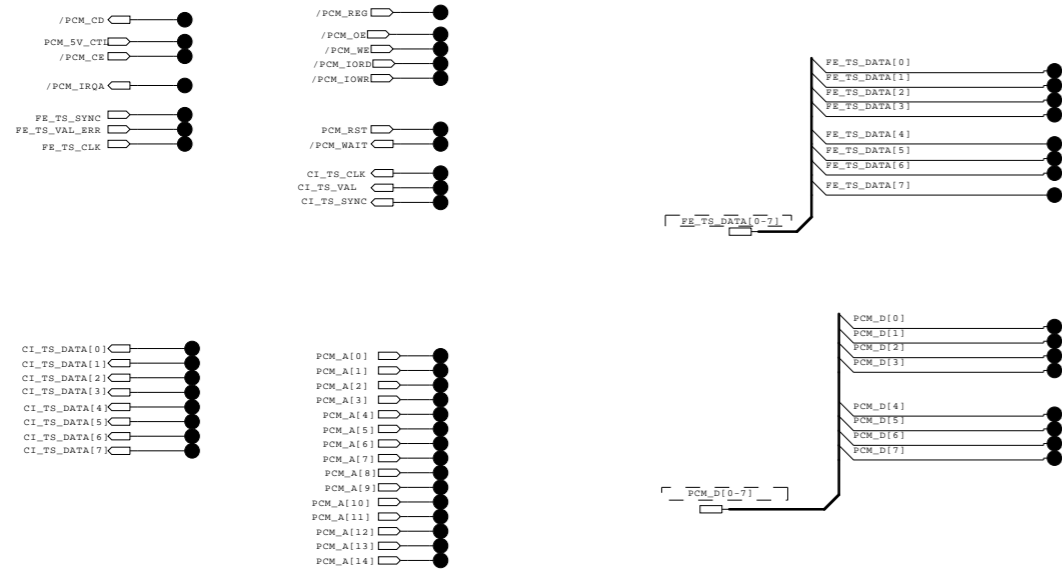

THE SYMBOL MARK OF THIS SCHEMATIC DIAGRAM INCORPORATES SPECIAL FEATURES IMPORTANT FOR PROTECTION FROM X-RADIATION. FILRE AND ELECTRICAL SHOCK HAZARDS, WHEN SERVICING IF IS ESSENTIAL THAT ONLY MANUFACTURES SPECIFIED PARTS BE USED FOR THE CRITICAL COMPONENTS IN THE SYMBOL MARK OF THE SCHEMATIC.



SECRET
LGElectronics

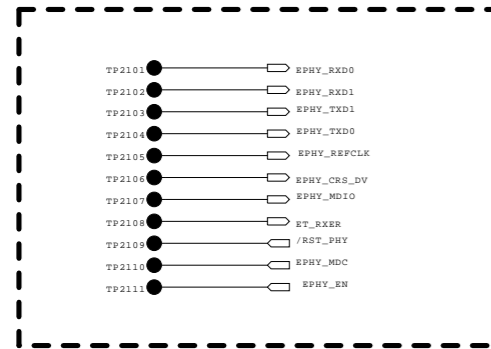

MODEL	GP2_Saturn7M	DATE	Ver. 1.0
BLOCK	PCMCI	SHEET	46 /

NON ETHERNET



THE  SYMBOL MARK OF THIS SCHEMATIC DIAGRAM INCORPORATES SPECIAL FEATURES IMPORTANT FOR PROTECTION FROM X-RADIATION. FILRE AND ELECTRICAL SHOCK HAZARDS, WHEN SERVICING IF IS ESSENTIAL THAT ONLY MANUFACTURES SPECIFIED PARTS BE USED FOR THE CRITICAL COMPONENTS IN THE  SYMBOL MARK OF THE SCHEMATIC.



SECRET
LGElectronics

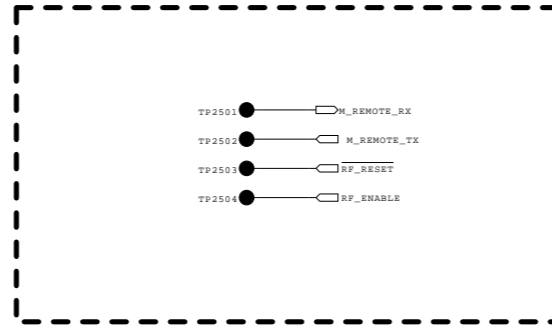

MODEL	GP2_Saturn7M	DATE	Ver. 1.0
BLOCK	NON ETHERNET	SHEET	48 /

NON Motion Remocon Region



THE  SYMBOL MARK OF THIS SCHEMATIC DIAGRAM INCORPORATES SPECIAL FEATURES IMPORTANT FOR PROTECTION FROM X-RADIATION. FILRE AND ELECTRICAL SHOCK HAZARDS, WHEN SERVICING IF IS ESSENTIAL THAT ONLY MANUFACTURES SPECIFIED PARTS BE USED FOR THE CRITICAL COMPONENTS IN THE  SYMBOL MARK OF THE SCHEMATIC.



SECRET
LGElectronics

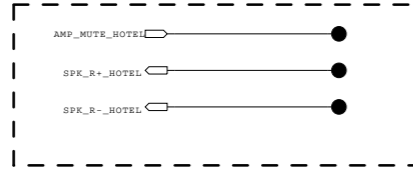

MODEL	GP2_Saturn7M	DATE	Ver. 1.0
BLOCK	NON M REMOCON	SHEET	50 /

NON CHINA HOTEL





THE  SYMBOL MARK OF THIS SCHEMATIC DIAGRAM INCORPORATES SPECIAL FEATURES IMPORTANT FOR PROTECTION FROM X-RADIATION. FILRE AND ELECTRICAL SHOCK HAZARDS, WHEN SERVICING IF IS ESSENTIAL THAT ONLY MANUFACTURES SPECIFIED PARTS BE USED FOR THE CRITICAL COMPONENTS IN THE  SYMBOL MARK OF THE SCHEMATIC.

SECRET
LGElectronics

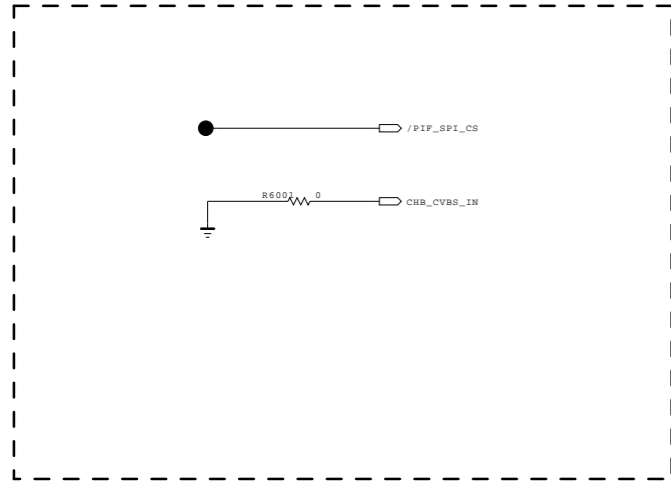

MODEL	GP2_Saturn7M	DATE	Ver. 1.0
BLOCK	NON CHINA HOTEL	SHEET	52 /



THE  SYMBOL MARK OF THIS SCHEMATIC DIAGRAM INCORPORATES SPECIAL FEATURES IMPORTANT FOR PROTECTION FROM X-RADIATION. FILRE AND ELECTRICAL SHOCK HAZARDS, WHEN SERVICING IF IS ESSENTIAL THAT ONLY MANUFATURES SPECIFIED PARTS BE USED FOR THE CRITICAL COMPONENTS IN THE  SYMBOL MARK OF THE SCHEMATIC.

SECRET
LGElectronics



MODEL	GP2_Saturn7M	DATE	Ver. 1.0
BLOCK	NON CHB	SHEET	68 /

