

Service  
Service  
**Service**



# Service Manual

Contents	Page
<a href="#">1. Revision List</a>	2
<a href="#">2. Technical Specs, Diversity, and Connections</a>	2
<a href="#">3. Precautions, Notes, and Abbreviation List</a>	5
<a href="#">4. Mechanical Instructions</a>	9
<a href="#">5. Service Modes, Error Codes, and Fault Finding</a>	14
<a href="#">6. Alignments (Option)</a>	23
<a href="#">7. Circuit Descriptions</a>	25
<a href="#">8. IC Data Sheets</a>	30
<a href="#">9. Block Diagrams</a>	
<a href="#">Wiring diagram 3000 series 32"</a>	33
<a href="#">Wiring diagram 3000 series 39"</a>	34
<a href="#">Wiring diagram 3000 series 42"-46"</a>	35
<a href="#">Block diagram 3000 series</a>	36
<a href="#">10. Circuit Diagrams and PWB Layouts</a>	<i>Drawing PWB</i>
<a href="#">A 715G5827 PSU</a>	37    39-40
<a href="#">A 715G5792 PSU</a>	41    46-47
<a href="#">A 715G6050 PSU</a>	48    51-52
<a href="#">B 715G5749 SSB</a>	53    63-64
<a href="#">J 715G5772 IR/LED Panel</a>	65    66
<a href="#">E 715G5771 Keyboard control panel</a>	67    68
<a href="#">11. Styling Sheets</a>	
<a href="#">3000 series 32"</a>	69
<a href="#">3000 series 39"</a>	70
<a href="#">3000 series 42"-46"</a>	71

Contents	Page
----------	------

# 1. Revision List

Manual xxxx xxx xxxx.0

- First release.

# 2. Technical Specs, Diversity, and Connections

Index of this chapter:

- [2.1 Technical Specifications](#)
- [2.2 Directions for Use](#)
- [2.3 Connections](#)
- [2.4 Chassis Overview](#)

Notes:

- Figures can deviate due to the different set executions.

- Specifications are indicative (subject to change).

## 2.1 Technical Specifications

For on-line product support please use the links in [Table 2-1](#). Here is product information available, as well as getting started, user manuals, frequently asked questions and software & drivers.

Table 2-1 Described Model Numbers and Diversity

CTN	2	4			9		10				11
	Connection Overview	Mechanics			Block Diagrams		Schematics				Styling
		Wire Dressing	Rear Cover Removal	SSB Removal	Wiring Diagram	Block Diagram	Power Supply	SSB	J (IR/LED)	E (Keyboard/Leading Edge)	
<a href="#">32PFL3008D/78</a>	<a href="#">2-1</a>	<a href="#">4-1</a>	<a href="#">4-4</a>	<a href="#">4-5</a>	<a href="#">9.1</a>	<a href="#">9.4</a>	<a href="#">10.1</a>	<a href="#">10.4</a>	<a href="#">10.5</a>	<a href="#">10.6</a>	<a href="#">11.1</a>
<a href="#">32PFL3008D/77</a>	<a href="#">2-1</a>	<a href="#">4-1</a>	<a href="#">4-4</a>	<a href="#">4-5</a>	<a href="#">9.1</a>	<a href="#">9.4</a>	<a href="#">10.1</a>	<a href="#">10.4</a>	<a href="#">10.5</a>	<a href="#">10.6</a>	<a href="#">11.1</a>
<a href="#">32PFL3018D/78</a>	<a href="#">2-1</a>	<a href="#">4-1</a>	<a href="#">4-4</a>	<a href="#">4-5</a>	<a href="#">9.1</a>	<a href="#">9.4</a>	<a href="#">10.1</a>	<a href="#">10.4</a>	<a href="#">10.5</a>	<a href="#">10.6</a>	<a href="#">11.1</a>
<a href="#">32PFL3018D/77</a>	<a href="#">2-1</a>	<a href="#">4-1</a>	<a href="#">4-4</a>	<a href="#">4-5</a>	<a href="#">9.1</a>	<a href="#">9.4</a>	<a href="#">10.1</a>	<a href="#">10.4</a>	<a href="#">10.5</a>	<a href="#">10.6</a>	<a href="#">11.1</a>
<a href="#">39PFL3008D/78</a>	<a href="#">2-1</a>	<a href="#">4-2</a>	<a href="#">4-4</a>	<a href="#">4-5</a>	<a href="#">9.2</a>	<a href="#">9.4</a>	<a href="#">10.3</a>	<a href="#">10.4</a>	<a href="#">10.5</a>	<a href="#">10.6</a>	<a href="#">11.2</a>
<a href="#">42PFL3008D/78</a>	<a href="#">2-1</a>	<a href="#">4-3</a>	<a href="#">4-4</a>	<a href="#">4-5</a>	<a href="#">9.3</a>	<a href="#">9.4</a>	<a href="#">10.2</a>	<a href="#">10.4</a>	<a href="#">10.5</a>	<a href="#">10.6</a>	<a href="#">11.3</a>
<a href="#">42PFL3008D/77</a>	<a href="#">2-1</a>	<a href="#">4-3</a>	<a href="#">4-4</a>	<a href="#">4-5</a>	<a href="#">9.3</a>	<a href="#">9.4</a>	<a href="#">10.2</a>	<a href="#">10.4</a>	<a href="#">10.5</a>	<a href="#">10.6</a>	<a href="#">11.3</a>
<a href="#">46PFL3008D/78</a>	<a href="#">2-1</a>	<a href="#">4-3</a>	<a href="#">4-4</a>	<a href="#">4-5</a>	<a href="#">9.3</a>	<a href="#">9.4</a>	<a href="#">10.2</a>	<a href="#">10.4</a>	<a href="#">10.5</a>	<a href="#">10.6</a>	<a href="#">11.3</a>

## 2.2 Directions for Use

Directions for use can be downloaded from the following websites:

- <http://www.philips.com/support>
- <http://www.p4c.philips.com>

2.3 Connections

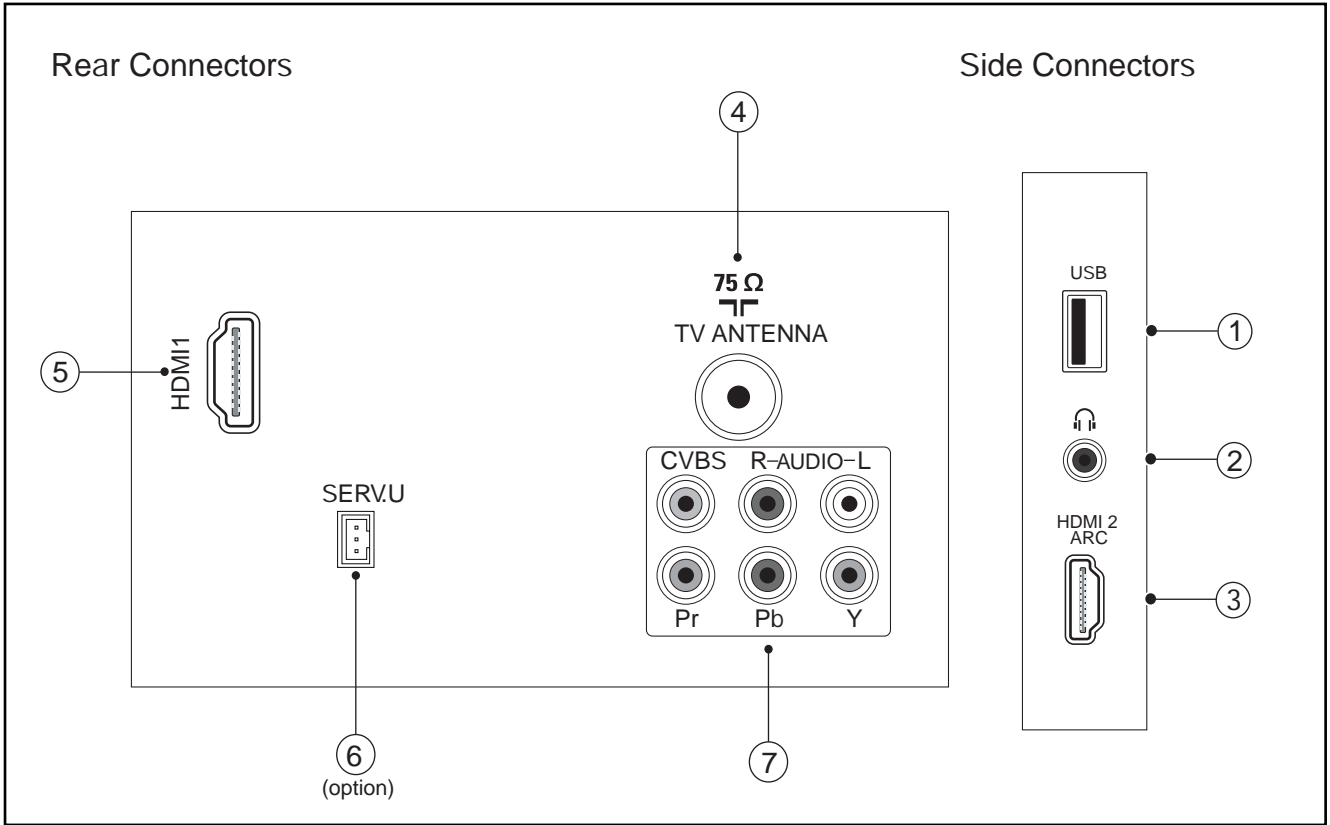

19500\_001\_130408.eps  
130408

Figure 2-1 Connection overview

**Note:** The following connector colour abbreviations are used (acc. to DIN/IEC 757): Bk= Black, Bu= Blue, Gn= Green, Gy= Grey, Rd= Red, Wh= White, Ye= Yellow.

2.3.1 Side Connections

1 - USB2.0

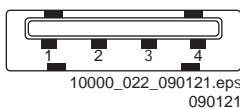
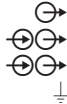

Figure 2-2 USB (type A)

- 1 - +5V
- 2 - Data (-)
- 3 - Data (+)
- 4 - Ground



2 - Head phone (Output)

Bk - Head phone 80 - 600 Ω / 10 mW



3 - HDMI2 : Digital Video - In, Digital Audio - In/Out

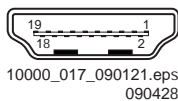

Figure 2-3 HDMI (type A) connector

- 1 - D2+ Data channel
- 2 - Shield Gnd
- 3 - D2- Data channel
- 4 - D1+ Data channel
- 5 - Shield Gnd
- 6 - D1- Data channel



2.3.2 Rear Connections

4 - TV ANTENNA - In

Signal input from an antenna, cable or satellite.

5 - HDMI 1: Digital Video - In, Digital Audio with ARC - In/Out

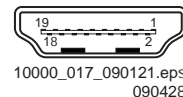

10000\_017\_090121.eps  
090428

Figure 2-4 HDMI (type A) connector

- 1 - D2+ Data channel
- 2 - Shield Gnd
- 3 - D2- Data channel
- 4 - D1+ Data channel
- 5 - Shield Gnd
- 6 - D1- Data channel
- 7 - D0+ Data channel



8	- Shield	Gnd	⊥
9	- D0-	Data channel	⊕
10	- CLK+	Data channel	⊕
11	- Shield	Gnd	⊥
12	- CLK-	Data channel	⊕
13	- Easylink/CEC	Control channel	⊕
14	- ARC	Audio Return Channel	⊕
15	- DDC_SCL	DDC clock	⊕
16	- DDC_SDA	DDC data	⊕
17	- Ground	Gnd	⊥
18	- +5V		⊕
19	- HPD	Hot Plug Detect	⊕
20	- Ground	Gnd	⊥

**6 - Service / UART**

1	- Ground	Gnd	⊥
2	- UART_TX	Transmit	⊕
3	- UART_RX	Receive	⊕

**7- Cinch: Video YPbPr - In, Audio - In**

Gn	- Video - Y	1 V <sub>PP</sub> / 75 Ω	⊕
Bu	- Video - Pb	0.7 V <sub>PP</sub> / 75 Ω	⊕
Rd	- Video - Pr	0.7 V <sub>PP</sub> / 75 Ω	⊕
Wh	- Audio - L	0.5 V <sub>RMS</sub> / 10 kΩ	⊕
Rd	- Audio - R	0.5 V <sub>RMS</sub> / 10 kΩ	⊕

**2.4 Chassis Overview**

Refer to [9. Block Diagrams](#) for PWB/CBA locations.

## 3. Precautions, Notes, and Abbreviation List

### Index of this chapter:

[3.1 Safety Instructions](#)

[3.2 Warnings](#)

[3.3 Notes](#)

[3.4 Abbreviation List](#)

### 3.1 Safety Instructions

Safety regulations require the following **during** a repair:

- Connect the set to the Mains/AC Power via an isolation transformer (> 800 VA).
- Replace safety components, indicated by the symbol h, only by components identical to the original ones. Any other component substitution (other than original type) may increase risk of fire or electrical shock hazard.

Safety regulations require that **after** a repair, the set must be returned in its original condition. Pay in particular attention to the following points:

- Route the wire trees correctly and fix them with the mounted cable clamps.
- Check the insulation of the Mains/AC Power lead for external damage.
- Check the strain relief of the Mains/AC Power cord for proper function.
- Check the electrical DC resistance between the Mains/AC Power plug and the secondary side (only for sets that have a Mains/AC Power isolated power supply):
  1. Unplug the Mains/AC Power cord and connect a wire between the two pins of the Mains/AC Power plug.
  2. Set the Mains/AC Power switch to the "on" position (keep the Mains/AC Power cord unplugged!).
  3. Measure the resistance value between the pins of the Mains/AC Power plug and the metal shielding of the tuner or the aerial connection on the set. The reading should be between 4.5 MW and 12 MW.
  4. Switch "off" the set, and remove the wire between the two pins of the Mains/AC Power plug.
- Check the cabinet for defects, to prevent touching of any inner parts by the customer.

### 3.2 Warnings

- All ICs and many other semiconductors are susceptible to electrostatic discharges (ESD w). Careless handling during repair can reduce life drastically. Make sure that, during repair, you are connected with the same potential as the mass of the set by a wristband with resistance. Keep components and tools also at this same potential.
- Be careful during measurements in the high voltage section.
- Never replace modules or other components while the unit is switched "on".
- When you align the set, use plastic rather than metal tools. This will prevent any short circuits and the danger of a circuit becoming unstable.

### 3.3 Notes

#### 3.3.1 General

- Measure the voltages and waveforms with regard to the chassis (= tuner) ground (H), or hot ground (I), depending on the tested area of circuitry. The voltages and waveforms shown in the diagrams are indicative. Measure them in the Service Default Mode with a colour bar signal and stereo sound (L: 3 kHz, R: 1 kHz unless stated otherwise) and picture carrier at 475.25 MHz for PAL, or 61.25 MHz for NTSC (channel 3).
- Where necessary, measure the waveforms and voltages with (D) and without (E) aerial signal. Measure the voltages in the power supply section both in normal operation (G) and in stand-by (F). These values are indicated by means of the appropriate symbols.

#### 3.3.2 Schematic Notes

- All resistor values are in ohms, and the value multiplier is often used to indicate the decimal point location (e.g. 2K2 indicates 2.2 kW).
- Resistor values with no multiplier may be indicated with either an "E" or an "R" (e.g. 220E or 220R indicates 220 W).
- All capacitor values are given in micro-farads ( $m = \cdot 10^{-6}$ ), nano-farads ( $n = \cdot 10^{-9}$ ), or pico-farads ( $p = \cdot 10^{-12}$ ).
- Capacitor values may also use the value multiplier as the decimal point indication (e.g. 2p2 indicates 2.2 pF).
- An "asterisk" (\*) indicates component usage varies. Refer to the diversity tables for the correct values.
- The correct component values are listed on the Philips Spare Parts Web Portal.

#### 3.3.3 Spare Parts

For the latest spare part overview, consult your Philips Spare Part web portal.

#### 3.3.4 BGA (Ball Grid Array) ICs

##### Introduction

For more information on how to handle BGA devices, visit this URL: <http://www.atyourservice-magazine.com>. Select "Magazine", then go to "Repair downloads". Here you will find information on how to deal with BGA-ICs.

##### BGA Temperature Profiles

For BGA-ICs, you **must** use the correct temperature-profile. Where applicable and available, this profile is added to the IC Data Sheet information section in this manual.

#### 3.3.5 Lead-free Soldering

Due to lead-free technology some rules have to be respected by the workshop during a repair:

- Use only lead-free soldering tin. If lead-free solder paste is required, please contact the manufacturer of your soldering equipment. In general, use of solder paste within workshops should be avoided because paste is not easy to store and to handle.
- Use only adequate solder tools applicable for lead-free soldering tin. The solder tool must be able:
  - To reach a solder-tip temperature of at least 400°C.
  - To stabilize the adjusted temperature at the solder-tip.
  - To exchange solder-tips for different applications.
- Adjust your solder tool so that a temperature of around 360°C - 380°C is reached and stabilized at the solder joint. Heating time of the solder-joint should not exceed ~ 4 sec. Avoid temperatures above 400°C, otherwise wear-out of tips will increase drastically and flux-fluid will be destroyed. To avoid wear-out of tips, switch "off" unused equipment or reduce heat.
- Mix of lead-free soldering tin/parts with leaded soldering tin/parts is possible but PHILIPS recommends strongly to **avoid** mixed regimes. If this cannot be avoided, carefully clear the solder-joint from old tin and re-solder with new tin.

#### 3.3.6 Alternative BOM identification

It should be noted that on the European Service website, "Alternative BOM" is referred to as "Design variant".

The **third digit** in the serial number (example: AG2B0335000001) indicates the number of the alternative B.O.M. (Bill Of Materials) that has been used for producing the specific TV set. In general, it is possible that the same TV model on the market is produced with e.g. two different types of displays, coming from two different suppliers. This will then

result in sets which have the same CTN (Commercial Type Number; e.g. 28PW9515/12) but which have a different B.O.M. number.

By looking at the third digit of the serial number, one can identify which B.O.M. is used for the TV set he is working with. If the third digit of the serial number contains the number "1" (example: AG1B033500001), then the TV set has been manufactured according to B.O.M. number 1. If the third digit is a "2" (example: AG2B033500001), then the set has been produced according to B.O.M. no. 2. This is important for ordering the correct spare parts!

For the third digit, the numbers 1...9 and the characters A...Z can be used, so in total: 9 plus 26= 35 different B.O.M.s can be indicated by the third digit of the serial number.

**Identification:** The bottom line of a type plate gives a 14-digit serial number. Digits 1 and 2 refer to the production centre (e.g. SN is Lysomice, RJ is Kobierzyce), digit 3 refers to the B.O.M. code, digit 4 refers to the Service version change code, digits 5 and 6 refer to the production year, and digits 7 and 8 refer to production week (in example below it is 2010 week 10 / 2010 week 17). The 6 last digits contain the serial number.



Figure 3-1 Serial number (example)

### 3.3.7 Board Level Repair (BLR) or Component Level Repair (CLR)

If a board is defective, consult your repair procedure to decide if the board has to be exchanged or if it should be repaired on component level.

If your repair procedure says the board should be exchanged completely, do not solder on the defective board. Otherwise, it cannot be returned to the O.E.M. supplier for back charging!

### 3.3.8 Practical Service Precautions

- **It makes sense to avoid exposure to electrical shock.** While some sources are expected to have a possible dangerous impact, others of quite high potential are of limited current and are sometimes held in less regard.
- **Always respect voltages.** While some may not be dangerous in themselves, they can cause unexpected reactions that are best avoided. Before reaching into a powered TV set, it is best to test the high voltage insulation. It is easy to do, and is a good service precaution.

## 3.4 Abbreviation List

0/6/12 SCART switch control signal on A/V board. 0 = loop through (AUX to TV),

6 = play 16 : 9 format, 12 = play 4 : 3 format

AARA	Automatic Aspect Ratio Adaptation: algorithm that adapts aspect ratio to remove horizontal black bars; keeps the original aspect ratio
ACI	Automatic Channel Installation: algorithm that installs TV channels directly from a cable network by means of a predefined TXT page
ADC	Analogue to Digital Converter
AFC	Automatic Frequency Control: control signal used to tune to the correct frequency
AGC	Automatic Gain Control: algorithm that controls the video input of the feature box
AM	Amplitude Modulation
AP	Asia Pacific
AR	Aspect Ratio: 4 by 3 or 16 by 9
ASF	Auto Screen Fit: algorithm that adapts aspect ratio to remove horizontal black bars without discarding video information
ATSC	Advanced Television Systems Committee, the digital TV standard in the USA
ATV	See Auto TV
Auto TV	A hardware and software control system that measures picture content, and adapts image parameters in a dynamic way
AV	External Audio Video
AVC	Audio Video Controller
AVIP	Audio Video Input Processor
B/G	Monochrome TV system. Sound carrier distance is 5.5 MHz
BDS	Business Display Solutions (iTV)
BLR	Board-Level Repair
BTSC	Broadcast Television Standard Committee. Multiplex FM stereo sound system, originating from the USA and used e.g. in LATAM and AP-NTSC countries
B-TXT	Blue TeleteXT
C	Centre channel (audio)
CEC	Consumer Electronics Control bus: remote control bus on HDMI connections
CL	Constant Level: audio output to connect with an external amplifier
CLR	Component Level Repair
ComPair	Computer aided rePair
CP	Connected Planet / Copy Protection
CSM	Customer Service Mode
CTI	Color Transient Improvement: manipulates steepness of chroma transients
CVBS	Composite Video Blanking and Synchronization
DAC	Digital to Analogue Converter
DBE	Dynamic Bass Enhancement: extra low frequency amplification
DCM	Data Communication Module. Also referred to as System Card or Smartcard (for iTV).
DDC	See "E-DDC"
D/K	Monochrome TV system. Sound carrier distance is 6.5 MHz
DFI	Dynamic Frame Insertion
DFU	Directions For Use: owner's manual
DMR	Digital Media Reader: card reader
DMSD	Digital Multi Standard Decoding
DNM	Digital Natural Motion



DNR	Digital Noise Reduction: noise reduction feature of the set		The SDI signal is self-synchronizing, uses 8 bit or 10 bit data words, and has a maximum data rate of 270 Mbit/s, with a minimum bandwidth of 135 MHz.
DRAM	Dynamic RAM		
DRM	Digital Rights Management		
DSP	Digital Signal Processing		
DST	Dealer Service Tool: special remote control designed for service technicians	iTV	Institutional TeleVision; TV sets for hotels, hospitals etc.
		LS	Last Status; The settings last chosen by the customer and read and stored in RAM or in the NVM. They are called at start-up of the set to configure it according to the customer's preferences
DTCP	Digital Transmission Content Protection; A protocol for protecting digital audio/video content that is traversing a high speed serial bus, such as IEEE-1394		
DVB-C	Digital Video Broadcast - Cable	LATAM	Latin America
DVB-T	Digital Video Broadcast - Terrestrial	LCD	Liquid Crystal Display
DVD	Digital Versatile Disc	LED	Light Emitting Diode
DVI(-d)	Digital Visual Interface (d= digital only)	L/L'	Monochrome TV system. Sound carrier distance is 6.5 MHz. L' is Band I, L is all bands except for Band I
E-DDC	Enhanced Display Data Channel (VESA standard for communication channel and display). Using E-DDC, the video source can read the EDID information form the display.	LPL	LG.Philips LCD (supplier)
		LS	Loudspeaker
		LVDS	Low Voltage Differential Signalling
EDID	Extended Display Identification Data (VESA standard)	Mbps	Mega bits per second
		M/N	Monochrome TV system. Sound carrier distance is 4.5 MHz
EEPROM	Electrically Erasable and Programmable Read Only Memory	MHEG	Part of a set of international standards related to the presentation of multimedia information, standardised by the Multimedia and Hypermedia Experts Group. It is commonly used as a language to describe interactive television services
EMI	Electro Magnetic Interference		
EPG	Electronic Program Guide		
EPLD	Erasable Programmable Logic Device		
EU	Europe		
EXT	EXternal (source), entering the set by SCART or by cinches (jacks)		
FDS	Full Dual Screen (same as FDW)	MIPS	Microprocessor without Interlocked Pipeline-Stages; A RISC-based microprocessor
FDW	Full Dual Window (same as FDS)		
FLASH	FLASH memory		
FM	Field Memory or Frequency Modulation	MOP	Matrix Output Processor
		MOSFET	Metal Oxide Silicon Field Effect Transistor, switching device
FPGA	Field-Programmable Gate Array		
FTV	Flat TeleVision	MPEG	Motion Pictures Experts Group
Gb/s	Giga bits per second	MPIF	Multi Platform InterFace
G-TXT	Green TeleteXT	MUTE	MUTE Line
H	H_sync to the module	MTV	Mainstream TV: TV-mode with Consumer TV features enabled (iTV)
HD	High Definition		
HDD	Hard Disk Drive	NC	Not Connected
HDCP	High-bandwidth Digital Content Protection: A "key" encoded into the HDMI/DVI signal that prevents video data piracy. If a source is HDCP coded and connected via HDMI/DVI without the proper HDCP decoding, the picture is put into a "snow vision" mode or changed to a low resolution. For normal content distribution the source and the display device must be enabled for HDCP "software key" decoding.	NICAM	Near Instantaneous Compounded Audio Multiplexing. This is a digital sound system, mainly used in Europe.
		NTC	Negative Temperature Coefficient, non-linear resistor
		NTSC	National Television Standard Committee. Color system mainly used in North America and Japan. Color carrier NTSC M/N= 3.579545 MHz, NTSC 4.43= 4.433619 MHz (this is a VCR norm, it is not transmitted off-air)
		NVM	Non-Volatile Memory: IC containing TV related data such as alignments
HDMI	High Definition Multimedia Interface		
HP	HeadPhone	O/C	Open Circuit
I	Monochrome TV system. Sound carrier distance is 6.0 MHz	OSD	On Screen Display
		OAD	Over the Air Download. Method of software upgrade via RF transmission. Upgrade software is broadcasted in TS with TV channels.
I <sup>2</sup> C	Inter IC bus		
I <sup>2</sup> D	Inter IC Data bus		
I <sup>2</sup> S	Inter IC Sound bus		
IF	Intermediate Frequency	OTC	On screen display Teletext and Control; also called Artistic (SAA5800)
IR	Infra Red		
IRQ	Interrupt Request	P50	Project 50: communication protocol between TV and peripherals
ITU-656	The ITU Radio communication Sector (ITU-R) is a standards body subcommittee of the International Telecommunication Union relating to radio communication. ITU-656 (a.k.a. SDI), is a digitized video format used for broadcast grade video.	PAL	Phase Alternating Line. Color system mainly used in West Europe (colour carrier = 4.433619 MHz) and South America (colour carrier PAL M = 3.575612 MHz and PAL N = 3.582056 MHz)
	Uncompressed digital component or digital composite signals can be used.	PCB	Printed Circuit Board (same as "PWB")
		PCM	Pulse Code Modulation

PDP	Plasma Display Panel	SWAN	Spatial temporal Weighted Averaging
PFC	Power Factor Corrector (or Pre-conditioner)	SXGA	Noise reduction 1280 × 1024
PIP	Picture In Picture	TFT	Thin Film Transistor
PLL	Phase Locked Loop. Used for e.g. FST tuning systems. The customer can give directly the desired frequency	THD	Total Harmonic Distortion
POD	Point Of Deployment: a removable CAM module, implementing the CA system for a host (e.g. a TV-set)	TMD5	Transmission Minimized Differential Signalling
POR	Power On Reset, signal to reset the uP	TS	Transport Stream
PSDL	Power Supply for Direct view LED backlight with 2D-dimming	TXT	TeleteXT
PSL	Power Supply with integrated LED drivers	TXT-DW	Dual Window with TeleteXT
PSLS	Power Supply with integrated LED drivers with added Scanning functionality	UI	User Interface
PTC	Positive Temperature Coefficient, non-linear resistor	uP	Microprocessor
PWB	Printed Wiring Board (same as "PCB")	UXGA	1600 × 1200 (4:3)
PWM	Pulse Width Modulation	V	V-sync to the module
QRC	Quasi Resonant Converter	VESA	Video Electronics Standards Association
QTNR	Quality Temporal Noise Reduction	VGA	640 × 480 (4:3)
QVCP	Quality Video Composition Processor	VL	Variable Level out: processed audio output toward external amplifier
RAM	Random Access Memory	VSF	Vestigial Side Band; modulation method
RGB	Red, Green, and Blue. The primary color signals for TV. By mixing levels of R, G, and B, all colors (Y/C) are reproduced.	WYSIWYR	What You See Is What You Record: record selection that follows main picture and sound
RC	Remote Control	WXGA	1280 × 768 (15:9)
RC5 / RC6	Signal protocol from the remote control receiver	XTAL	Quartz crystal
RESET	RESET signal	XGA	1024 × 768 (4:3)
ROM	Read Only Memory	Y	Luminance signal
RSDS	Reduced Swing Differential Signalling data interface	Y/C	Luminance (Y) and Chrominance (C) signal
R-TXT	Red TeleteXT	YPbPr	Component video. Luminance and scaled color difference signals (B-Y and R-Y)
SAM	Service Alignment Mode	YUV	Component video
S/C	Short Circuit		
SCART	Syndicat des Constructeurs d'Appareils Radiorécepteurs et Téléviseurs		
SCL	Serial Clock I <sup>2</sup> C		
SCL-F	CLock Signal on Fast I <sup>2</sup> C bus		
SD	Standard Definition		
SDA	Serial Data I <sup>2</sup> C		
SDA-F	DAta Signal on Fast I <sup>2</sup> C bus		
SDI	Serial Digital Interface, see "ITU-656"		
SDRAM	Synchronous DRAM		
SECAM	SEquence Couleur Avec Mémoire. Colour system mainly used in France and East Europe. Colour carriers = 4.406250 MHz and 4.250000 MHz		
SIF	Sound Intermediate Frequency		
SMPS	Switched Mode Power Supply		
SoC	System on Chip		
SOG	Sync On Green		
SOPS	Self Oscillating Power Supply		
SPI	Serial Peripheral Interface bus; a 4-wire synchronous serial data link standard		
S/PDIF	Sony Philips Digital InterFace		
SRAM	Static RAM		
SRP	Service Reference Protocol		
SSB	Small Signal Board		
SSC	Spread Spectrum Clocking, used to reduce the effects of EMI		
STB	Set Top Box		
STBY	STand-BY		
SVGA	800 × 600 (4:3)		
SVHS	Super Video Home System		
SW	Software		



## 4. Mechanical Instructions

Index of this chapter:

[4.1 Cable Dressing](#)

[4.2 Service Positions](#)

[4.3 Assembly/Panel Removal](#)

[4.4 Set Re-assembly](#)

Notes:

- Figures below can deviate slightly from the actual situation, due to the different set executions.

### 4.1 Cable Dressing

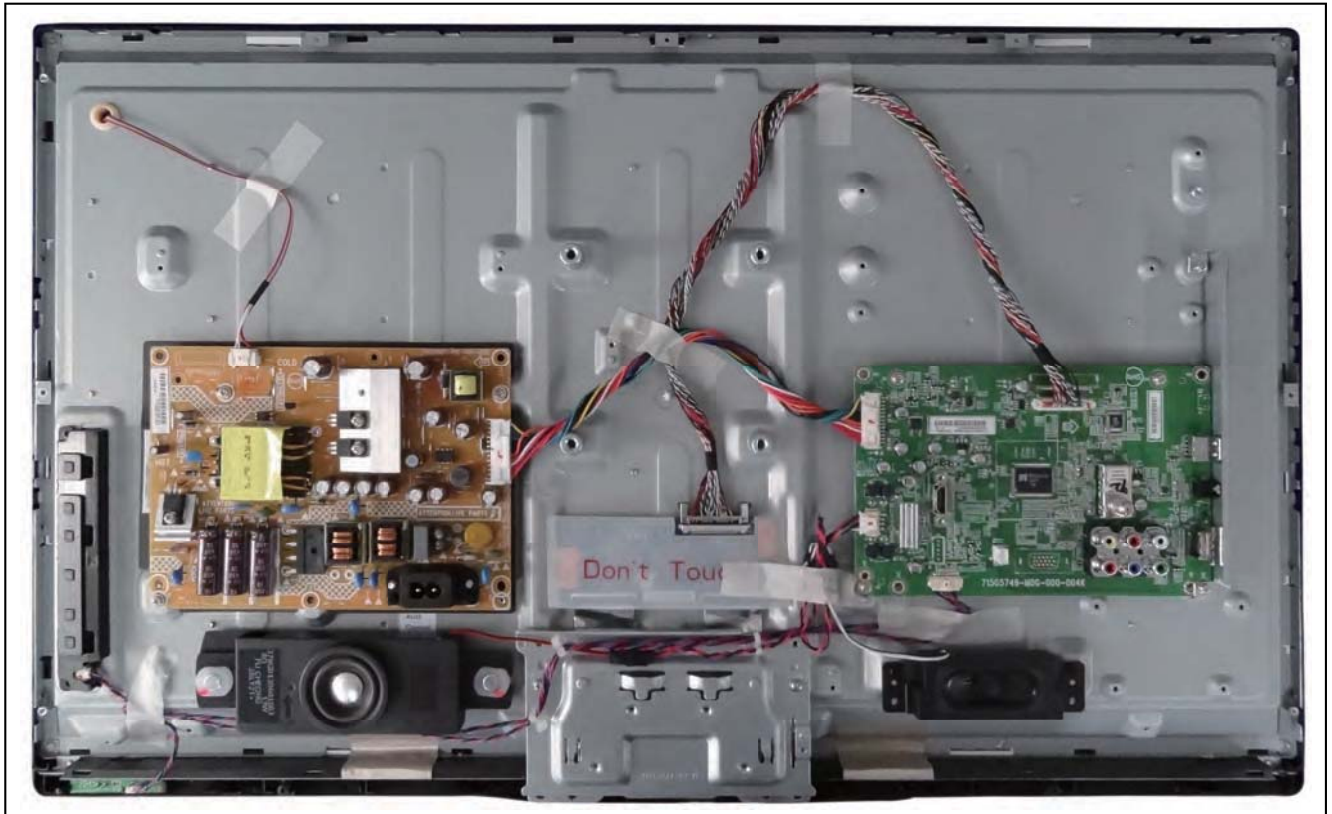

19500\_100\_130411.eps  
130411

Figure 4-1 Cable dressing (32" 3000 series)

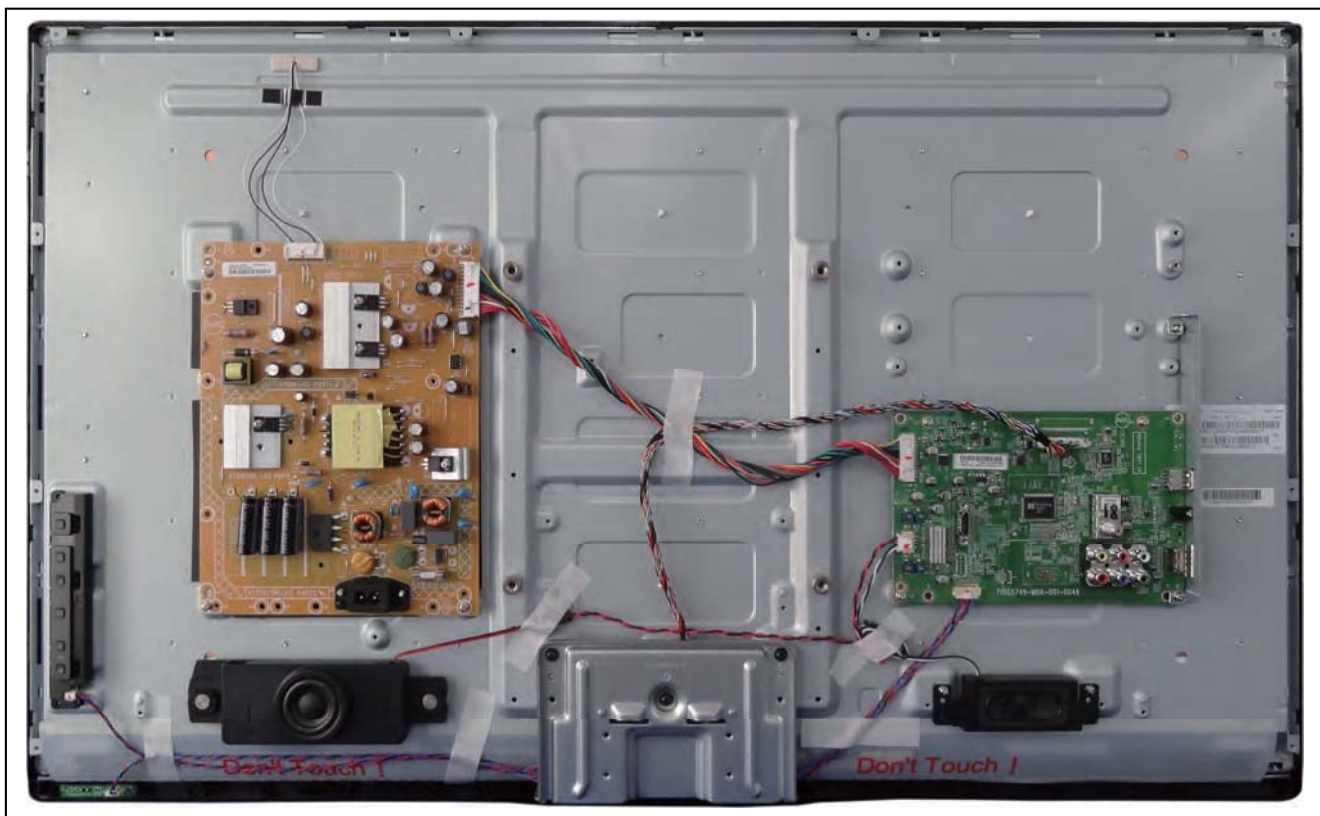

19500\_101\_130411.eps  
130411

Figure 4-2 Cable dressing (39" 3000 series)

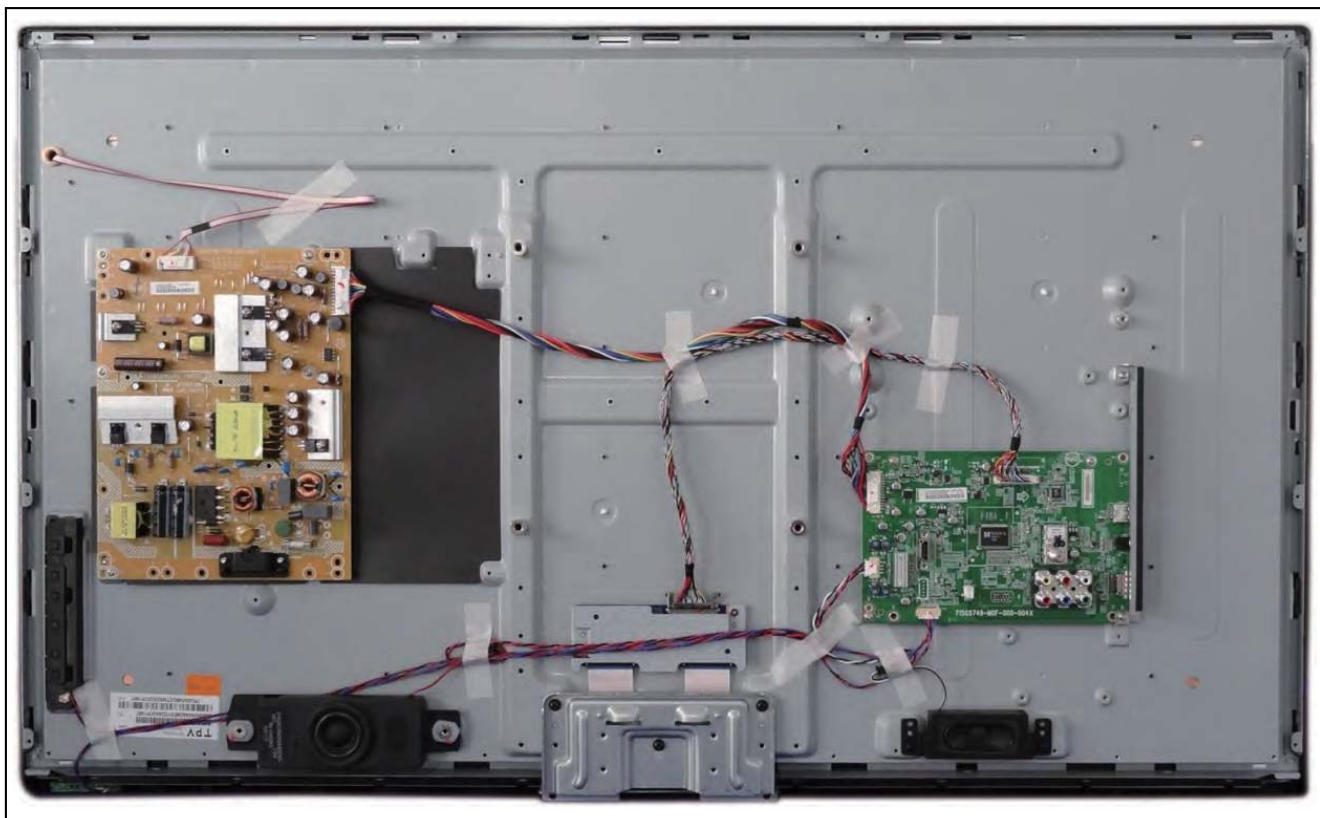

19500\_102\_130411.eps  
130411

Figure 4-3 Cable dressing (42"-46" 3000 series)

#### 4.2 Service Positions

For easy servicing of a TV set, the set should be put face down on a soft flat surface, foam buffers or other specific workshop tools. Ensure that a stable situation is created to perform measurements and alignments. When using foam bars take care that these always support the cabinet and **never** only the display. **Caution:** Failure to follow these guidelines can seriously damage the display!  
Ensure that ESD safe measures are taken.

#### 4.3 Assembly/Panel Removal

Instructions below apply to the 32PFL3018D/78, but will be similar for other series models.

#### 4.3.1 Rear Cover

Refer to [Figure 4-4](#) for details.

**Warning:** Disconnect the mains power cord before removing the rear cover.

1. Remove fixation screws [1] that secure the base assy, pull out the base assy from the set. Then remove the fixation

screws [2], [3] that secure the rear cover. Refer to [Figure 4-4](#) for details.

2. Gently lift the rear cover from the TV. Make sure that wires and cables are not damaged while lifting the rear cover from the set.



19500\_103\_130411.eps  
130411

Figure 4-4 Rear cover removal

#### 4.3.2 Small Signal Board (SSB)

Refer to [Figure 4-5](#) for details.

**Caution:** it is mandatory to remount all different screws at their original position during re-assembly. Failure to do so may result in damaging the SSB.

1. Release the clips from the LVDS connector that connect with the SSB [1].  
**Caution:** be careful, as these are very fragile connectors!
2. Unplug all other connectors [2].
3. Remove all the fixation screws from the SSB [3].
4. The SSB can now be shifted from side connector cover, then lifted and taken out of the I/O bracket. Refer to [Figure 4-5](#) for details.

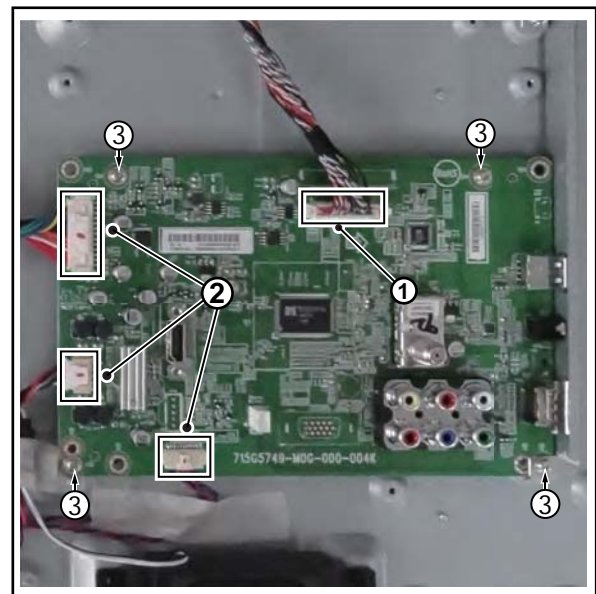

19500\_104\_130411.eps  
130411

Figure 4-5 SSB removal

### 4.3.3 Power Supply Unit (PSU)

**Caution:** it is mandatory to remount all different screws at their original position during re-assembly. Failure to do so may result in damaging the PSU.

1. Gently unplug all connectors from the PSU.
2. Remove all fixation screws from the PSU.
3. The PSU can be taken out of the set now.

### 4.3.4 Speakers

1. Gently release the tapes that secures the speaker cables.
2. Unplug the speaker connectors from the SSB.
3. Take the speakers out.

When defective, replace the both units.

### 4.3.5 Keyboard Control unit

1. Unplug the connector from the keyboard control panel.
2. Gently push inwards the two clips at the PSU side of the unit. Release the unit at the PSU side and turn it away from the PSU. Now push it towards the PSU to release the catches at the other side of the unit. Take it out from the metal bracket.

When defective, replace the whole unit.

### 4.3.6 Stand bracket

1. Remove all fixation screws of the bracket.
2. Lift the bracket from the set.

### 4.3.7 IR/LED Panel

1. Remove the stand bracket, as described earlier.
2. Unplug the connector from the IR/LED panel.
3. Gently release the clip that holds the panel and take it out from the bezel.

When defective, replace the whole unit.

### 4.3.8 LCD Panel

1. Remove the SSB as described earlier.
2. Remove the PSU as described earlier.
3. Remove the keyboard control panel as described earlier.
4. Remove the stand bracket as described earlier.
5. Remove the IR/LED as described earlier.
6. Remove the fixations screws that fix the metal clamps to the front bezel. Take out those clamps.
7. Remove all other metal parts not belonging to the panel.
8. Lift the LCD Panel from the bezel.

When defective, replace the whole unit.

## 4.4 Set Re-assembly

To re-assemble the whole set, execute all processes in reverse order.

#### Notes:

- While re-assembling, make sure that all cables are placed and connected in their original position. See [Figure 4-1](#).
- Pay special attention not to damage the EMC foams on the SSB shields. Ensure that EMC foams are mounted correctly.



## 5. Service Modes, Error Codes, and Fault Finding

### Index of this chapter:

- [5.1 Test Points](#)
- [5.2 Service Modes](#)
- [5.3 Stepwise Start-up](#)
- [5.4 Service Tools](#)
- [5.5 Software Upgrading](#)
- [5.6 Error Codes](#)
- [5.7 The Blinking LED Procedure](#)
- [5.8 Fault Finding and Repair Tips](#)

### 5.1 Test Points

As most signals are digital, it will be difficult to measure waveforms with a standard oscilloscope. However, several key ICs are capable of generating test patterns, which can be controlled via ComPair. In this way it is possible to determine which part is defective.

Perform measurements under the following conditions:

- Service Default Mode.
- Video: Colour bar signal.
- Audio: 3 kHz left, 1 kHz right.

### 5.2 Service Modes

The Service Mode feature is split into five parts:

- Service Default Mode (SDM).
- Service Alignment Mode (SAM).
- Factory Mode.
- Customer Service Mode (CSM).
- Computer Aided Repair Mode (ComPair).

SDM, SAM and the Factory mode offer features, which can be used by the Service engineer to repair/align a TV set. Some features are:

- A pre-defined situation to ensure measurements can be made under uniform conditions (SDM).
- Activates the blinking LED procedure for error identification when no picture is available (SDM).
- Make alignments (e.g. White Tone), reset the error buffer (SAM and Factory Mode).
- Display information ("SDM" or "SAM" indication in upper right corner of screen, error buffer, software version, operating hours, options and option codes, sub menus).

The CSM is a Service Mode that can be enabled by the consumer. The CSM displays diagnosis information, which the customer can forward to the dealer or call centre. In CSM mode, "CSM", is displayed in the top right corner of the screen. The information provided in CSM and the purpose of CSM is to:

- Increase the home repair hit rate.
- Decrease the number of nuisance calls.
- Solved customers' problem without home visit.

ComPair Mode is used for communication between a computer and a TV on I<sup>2</sup>C /UART level and can be used by a Service engineer to quickly diagnose the TV set by reading out error codes, read and write in NVMs, communicate with ICs and the micro processor (PWM, registers, etc.), and by making use of a fault finding database. It will also be possible to up and download the software of the TV set via I<sup>2</sup>C with help of ComPair. To do this, ComPair has to be connected to the TV set via the ComPair connector, which will be accessible through the rear of the set (without removing the rear cover).

**Note:** For the new model range, a new remote control (RC) is used with some renamed buttons. This has an impact on the activation of the Service modes. For instance the old "MENU" button is now called "HOME" (or is indicated by a "house" icon).

#### 5.2.1 General

Next items are applicable to all Service Modes or are general.

#### Life Timer

During the life time cycle of the TV set, a timer is kept (called "Op. Hour"). It counts the normal operation hours (not the Stand-by hours). The actual value of the timer is displayed in SDM and SAM in a decimal value. Every two soft-resets increase the hour by + 1. Stand-by hours are not counted.

#### Software Identification, Version, and Cluster

The software ID, version, and cluster will be shown in the main menu display of SDM, SAM, and CSM.

The screen will show: "AAAAB-X.YYY", where:

- AAAA is the chassis name: 2K13TPS1011L x.yy.
- B is the region indication: E = Europe, A = AP/China, U = NAFTA, L = LATAM.
- X is the main version number: this is updated with a major change of specification (incompatible with the previous software version). Numbering will go from 1 - 99 and AA - ZZ.
  - If the main version number changes, the new version number is written in the NVM.
  - If the main version number changes, the default settings are loaded.
- YYY is the sub version number: this is updated with a minor change (backwards compatible with the previous versions). Numbering will go from 000 - 999.
  - If the sub version number changes, the new version number is written in the NVM.
  - If the NVM is refreshed, the software identification, version, and cluster will also be written to NVM.

#### Display Option Code Selection(option)

When after an SSB or display exchange, the display option code is not set properly, it will result in a TV with "no display". Therefore, it is required to set this display option code after such a repair.

To do so, press the following key sequence on a standard RC transmitter: "062598" directly followed by MENU and "xxx", where "xxx" is a 3 digit decimal value of the panel type: see column "Display Code" in [Table 6-3](#). When the value is accepted and stored in NVM, the set will switch to Stand-by, to indicate that the process has been completed.

During this algorithm, the NVM-content must be filtered, because several items in the NVM are TV-related and not SSB related (e.g. Model and Prod. S/N). Therefore, "Model" and "Prod. S/N" data is changed into "See Type Plate". In case a call centre or consumer reads "See Type Plate" in CSM mode.

#### 5.2.2 Service Default Mode (SDM)(option)

##### Purpose

Set the TV in SDM mode in order to be able to create a predefined setting for measurements to be made. In this platform, a simplified SDM is introduced (without protection override and without tuning to a predefined frequency).

##### Specifications

- Set linear video and audio settings to 50%, but volume to 25%. Stored user settings are not affected.
- All service-unfriendly modes (if present) are disabled, since they interfere with diagnosing/repairing a set. These service unfriendly modes are:
  - (Sleep) timer.
  - Blue mute/Wall paper.
  - Auto switch "off" (when there is no "ident" signal).
  - Hotel or hospital mode.
  - Child lock or parental lock (manual or via V-chip).
  - Skipping, blanking of "Not favourite", "Skipped" or "Locked" presets/channels.
  - Automatic storing of Personal Preset or Last Status settings.



- Automatic user menu time-out (menu switches back/OFF automatically).
- Auto Volume levelling (AVL).

### How to Activate SDM

To activate SDM, use the following methods:

- Press the following key sequence on the RC transmitter: "062596", directly followed by the "Home" button.

After activating this mode, "SDM" will appear in the upper left corner of the screen.

### On Screen Menu

After activating SDM, the following items are displayed, with SDM in the upper right corner of the screen to indicate that the television is in Service Default Mode. Menu items and explanation:

- **xxxxx** Operating hours (in decimal).
- **AAAAB-X.YYY** See [Software Identification, Version, and Cluster](#) for the software name definition.
- **ERR** Shows all errors detected since the last time the buffer was erased in format <xxx> <xxx> <xxx> <xxx> <xxx> (five errors possible).
- **OP** Used to read-out the option bytes. In this chassis two times eight option codes are used.

### How to Navigate

As this mode is read only, there is nothing to navigate. To switch to other modes, use one of the following methods:

- Command MENU from the user remote will exit SDM.
- To prevent the OSD from interfering with measurements in SDM, use the command "Adjust" or "Options" ("STATUS" or "INFO" for NAFTA and LATAM) from the user remote. This will switch the OSD "off" while remaining in the SDM mode. The "SDM" OSD is remains visible in the upper right corner of the screen. To exit SDM switch to "Stand-by" mode.
- Press the following key sequence on the remote control transmitter: "062596" directly followed by the OK button to switch to SAM (do not allow the display to time out between entries while keying the sequence). Remarks: new remote

controls will not have I+ button, but an "INFO" button instead.

### How to Exit SDM

- Switch the set to Stand-by, by pressing the standby button on the remote control transmitter or on the television set.
- Via a standard customer RC-transmitter: key in "00"-sequence.

**Note:** If the TV is switched "off" by a power interrupt while in SDM, the TV will show up in the last status of SDM menu as soon as the power is supplied again. The error buffer will not be cleared.

## 5.2.3 Service Alignment Mode (SAM)(option)

### Purpose

- To modify the NVM.
- To display/clear the error code buffer.
- To perform alignments.

### Specifications

- Operation hours counter (maximum five digits displayed).
- Software version, error codes, and option settings display.
- Error buffer clearing.
- Option settings.
- Software alignments (White Tone).
- NVM Editor.
- Set screen mode to full screen (all content is visible).

### How to Activate SAM

To activate SAM, use one of the following methods:

- Press the following key sequence on the remote control transmitter: "062596", directly followed by the "INFO" button. Do not allow the display to time out between entries while keying the sequence.
- Or via ComPair.

After entering SAM, the following items are displayed, with "SAM" in the upper right corner of the screen to indicate that the television is in Service Alignment Mode.

Table 5-1 SAM mode overview

Main Menu	Sub-menu 1	Sub-menu 2	Description
System Information	Op Hour	e.g. 00003	This represents the life timer. The timer counts normal operation hours, but does not count Stand-by hours.
	Main SW ID	e.g. "TPM1012E 1.027B"	See paragraph <a href="#">Software Identification, Version, and Cluster</a> for the software name definition.
	ERR	e.g. "000 000 000 000 000"	Shows all errors detected since the last time the buffer was erased. Five errors possible.
	OP1	e.g. "000 224 032 000 038 192 192 015"	Used to read-out the option bytes. See paragraph <a href="#">6.4 Option Settings</a> in the Alignments section for a detailed description. Ten codes are possible.
	OP2	e.g. "159 255 127 061 011003 000 000"	
Clear Codes	Press [OK] to clean the Error Codes immediately		Erases the contents of the error buffer. Select this menu item and press the MENU RIGHT key on the remote control. The content of the error buffer is cleared.
Options	OP#1-OP#8	e.g. "032"	Option code
RGB Align	Warm	R Gain	To align the White Tone. See paragraph <a href="#">6.3 Software Alignments</a> in the Alignments section for a detailed description
		G Gain	
		B Gain	
	Normal	R Gain	
		G Gain	
		B Gain	
	Cool	R Gain	
G Gain			
Store		Store the RGB value	
NVM editor	Address		Select and fill the NVM address
	Value		Select and fill the NVM value
	Store		Store the value in the address
Upload to USB	Copy Channel List to USB		To upload several settings from the TV to an USB stick
	Copy NVM to USB		
	Copy Readable Info to USB		
	Copy EDID to USB		

Main Menu	Sub-menu 1	Sub-menu 2	Description
Download from USB	Copy Channel List from USB		To download several settings from the USB stick to the TV
	Copy NVM from USB		
	Copy Readable Info from USB		
	Copy EDID from USB		
Initialize NVM	Press [OK] to Initialize NVM immediately		To initialize a (corrupted) NVM. Be careful, this will erase all settings.
Service Data	Type Number	Press [OK] use key pad edit type number immediately	Edit and display the applicable service data by using the displayed key pad.
	Production Number	Press [OK] use key pad edit production number immediately	
	12NC SSB	Press [OK] use key pad edit SSB immediately	
	12NC PSU	Press [OK] use key pad edit PSU immediately	
	12NC Display	Press [OK] use key pad edit display immediately	
Dealer Options	Set Virgin mode	Virgin mode:Off	Set Virgin mode
	Store	Press [OK] to store virgin mode immediately	Store the virgin mode in the address
Event Count	Software Events	0000 0000	Software Events
	Hardware Events	0000 0000	Hardware Events
	Clear Software Events	Press [OK] to clear software events immediately	Clear Software Events
	Clear Hardware Events	Press [OK] to clear hardware events immediately	Clear Hardware Events

### How to Navigate

- In the SAM menu, select menu items with the UP/DOWN keys on the remote control transmitter. The selected item will be indicated. When not all menu items fit on the screen, use the UP/DOWN keys to display the next/previous menu items.
- With the "LEFT/RIGHT" keys, it is possible to:
  - (De) activate the selected menu item.
  - (De) activate the selected sub menu.
  - Change the value of the selected menu item.
- When you press the MENU button once while in top level SAM, the set will switch to the normal user menu (with the SAM mode still active in the background).
- Press the following key sequence on the remote control transmitter: "062596" directly followed by the "Home" button to switch to SDM (do not allow the display to time out between entries while keying the sequence).

### How to Store SAM Settings

To store the settings changed in SAM mode (except the RGB Align settings), leave the top level SAM menu by using the POWER button on the remote control transmitter or the television set. The mentioned exceptions must be stored separately via the STORE button.

### How to Exit SAM

Use one of the following methods:

- Switch the set to STANDBY by pressing the mains button on the remote control transmitter or the television set.
- Via a standard RC-transmitter, key in "00" sequence.

**Note:** When the TV is switched "off" by a power interrupt while in SAM, the TV will show up in "normal operation mode" as soon as the power is supplied again. The error buffer will not be cleared.

### 5.2.4 Contents of the Factory mode:

#### Purpose

- To perform extended alignments.

#### Specifications

- Displaying and or changing Panel ID information.
- Displaying and or changing Tuner ID information.
- Error buffer clearing.
- Various software alignment settings.
- Testpattern displaying.
- Public Broadcasting Service password Reset.
- etc.

#### How to Activate the Factory mode

To activate the Factory mode, use the following method:

- Press the following key sequence on the remote control transmitter: from the "Home screen" press "1999", directly followed by the "Back" button. Do not allow the display to time out between entries while keying the sequence.

After entering the Factory mode, the following items are displayed,

Table 5-2 Factory mode overview

Item	Item value	Default value			Description
		32"	39"	42"	
0	Main-MCU Ver	V1.00	V2.06	V1.03	Main-MCU Version
1	Bootloader Ver	V0.01			Bootloader Version
2	Sub-MCU Ver	NA			SUB-MCU Version
3	EEPROM Ver	NA			EEPROM Version
4	Date	Dec 24 2012	Mar 18 2013	Jan 22 2013	Software release date
5	ModelName	32PFL3 018D	39PFL 3008D	42PFL 3008D	Model name
6	Scaler	MST6931XP			Scaler model
7	Panel Type	TPT315 B5-A05 1	TPT39 QJ1-HV N01	TPT42 0H2-H VN04	Display model
8	Source	DTV	ATV	HDMI1	Input source
9	Auto Color	GO			Only need to do automatic correction input source of effective,otherwise it is not action

Item	Item value	Default value			Description
		32"	39"	42"	
10	W/B Pattern	OFF			W/B Pattern
11	ADC				ADC
12	Gain	R61	G60	B61	ADC Gain
13	Offset	R64	G8	B64	Offset RGB
14	ColorTemp	cool			The current set of color temperature
15	Scaler	MST6931XP			Scaler model
16	Gain	R137	G128	B133	ADC Gain
17	Offset	R128	G128	B128	Offset RGB
18	Burn in	OFF			Turn on or turn off Burn in pattern
19	V-COM				V-COM
20	Bcak LIT Time	01340.0 Hrs Hrs	00000. 0Hrs Hrs	00000. 3Hrs Hrs	Bcaklight time
21	Total Time	01416.4 Hrs Hrs	00000. 0Hrs Hrs	S0640. 7Hrs Hrs	Total time
22	BackLight	100			Set the brightness of the backlight
23	Language	English			Factory Lanuguage
24	System Reset				Reset the EEPROM data except the HDCP,product serial number,the factory menu ADC data,white balance set point,Black light,language and Energy Logo.
25	Exit				Exit

### How to Exit the Factory mode

Use one of the following methods:

- Select EXIT\_FACTORY from the menu and press the "OK" button.

**Note:** When the TV is switched "off" by a power interrupt, or normal switch to "stand-by" while in the factory mode, the TV will show up in "normal operation mode" as soon as the power is supplied again. The error buffer will not be cleared.

## 5.2.5 Customer Service Mode (CSM)

### Purpose

The Customer Service Mode shows error codes and information on the TVs operation settings. The call centre can instruct the customer (by telephone) to enter CSM in order to identify the status of the set. This helps the call centre to diagnose problems and failures in the TV set before making a service call.

The CSM is a read-only mode; therefore, modifications are not possible in this mode.

### Specifications

- Ignore "Service unfriendly modes".
- Line number for every line (to make CSM language independent).
- Set the screen mode to full screen (all contents on screen is visible).
- After leaving the Customer Service Mode, the original settings are restored.
- Possibility to use "CH+" or "CH-" for channel surfing, or enter the specific channel number on the RC.

### How to Activate CSM

To activate CSM, press the following key sequence on a standard remote control transmitter: "123654" (do not allow the display to time out between entries while keying the sequence). After entering the Customer Service Mode, the following items are displayed.

**Note:** Activation of the CSM is only possible if there is no (user) menu on the screen!

### Contents of CSM

- **1.1 Set Type** This information is very helpful for a helpdesk/workshop as reference for further diagnosis. In this way, it is not necessary for the customer to look at the rear of the TV-set. Note that if an NVM is replaced or is initialized after corruption, this set type has to be re-written to NVM.

- **1.2 Production code** Displays the production code (the serial number) of the TV. Note that if an NVM is replaced or is initialized after corruption, this production code has to be re-written to NVM.
- **1.3 Installation date** Indicates the date of the first installation of the TV. This date is acquired via time extraction.
- **1.4 Option Code 1** Gives the option codes of option group 1 as set in SAM.
- **1.5 Option Code 2** Gives the option codes of option group 2 as set in SAM.
- **1.6 SSB** Gives an identification of the SSB as stored in NVM. Note that if an NVM is replaced or is initialized after corruption, this identification number has to be re-written to NVM. This identification number is the 12NC number of the SSB.
- **1.7 Display** 12NC NVM read/write.
- **1.8 PSU** 12NC NVM read/write.
- **2.1 Current Main SW** Displays the built-in main software version. In case of field problems related to software, software can be upgraded. As this software is consumer upgradeable, it will also be published on the internet.
- **2.2 Standby SW** Displays the built-in stand-by processor software version. Upgrading this software will be possible via USB.
- **2.3 Panel Code** Displays the Display Code number.
- **2.4 NVM version** Detects and displays NVM version.
- **2.5 Error Codes** Detects and displays errors.
- **3.1 Signal Quality** Analog/digital signal strength.
- **3.2 Child lock** Not active / active. This is a combined item for locks. If any lock (channel lock, parental lock) is active, it is indicated as "active".
- **3.3 HDCP keys** Indicates the validity of the HDMI keys (or HDCP keys). In case these keys are not valid and the customer wants to make use of the HDMI functionality, the SSB has to be replaced.
- **3.4 Ethernet MAC address** A Media Access Control address (MAC address) is a unique identifier assigned to network interfaces for communications on the physical network segment.
- **3.5 Wireless MAC address** Wireless Media Access Control address.

### How to Navigate

By means of the "CURSOR-DOWN/UP" knob (or the scroll wheel) on the RC-transmitter, can be navigated through the menus.

### How to Exit CSM

To exit CSM, use one of the following methods.

- Press the MENU/HOME button on the remote control transmitter.
- Press the POWER button on the remote control transmitter.
- Press the POWER button on the television set.

### 5.3 Stepwise Start-up

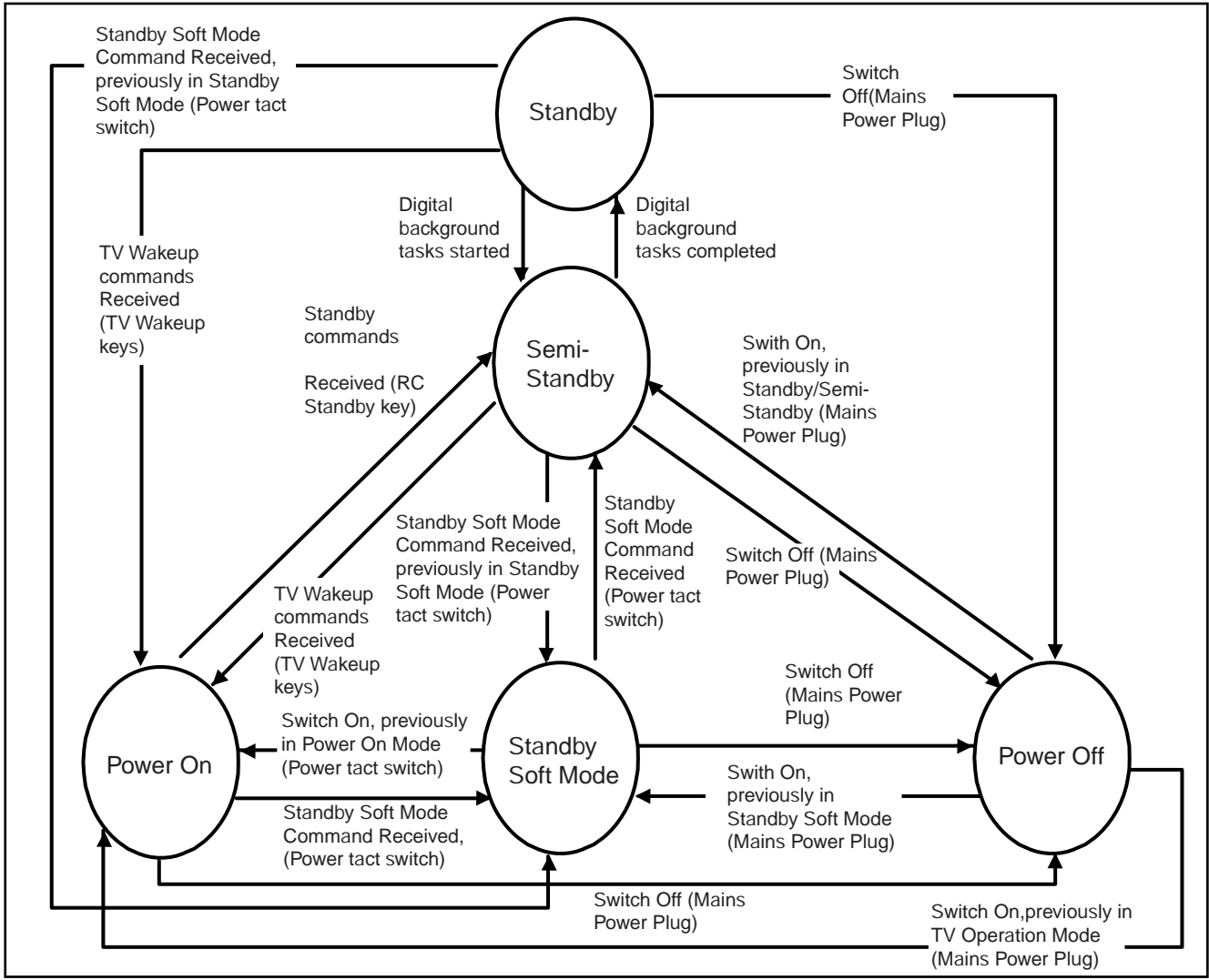

19080\_206\_110323.eps  
120224

Figure 5-1 Stepwise Start-up

## 5.4 Service Tools

### 5.4.1 ComPair

#### Introduction

ComPair (Computer Aided Repair) is a Service tool for Philips Consumer Electronics products. and offers the following:

1. ComPair helps to quickly get an understanding on how to repair the chassis in a short and effective way.
2. ComPair allows very detailed diagnostics and is therefore capable of accurately indicating problem areas. No knowledge on I<sup>2</sup>C or UART commands is necessary, because ComPair takes care of this.
3. ComPair speeds up the repair time since it can automatically communicate with the chassis (when the micro processor is working) and all repair information is directly available.
4. ComPair features TV software up possibilities.

#### Specifications

ComPair consists of a Windows based fault finding program and an interface box between PC and the (defective) product. The ComPair II interface box is connected to the PC via an USB cable. For the TV chassis, the ComPair interface box and the TV communicate via a bi-directional cable via the service connector(s).

The ComPair fault finding program is able to determine the problem of the defective television, by a combination of automatic diagnostics and an interactive question/answer procedure.

#### How to Connect

This is described in the chassis fault finding database in ComPair.

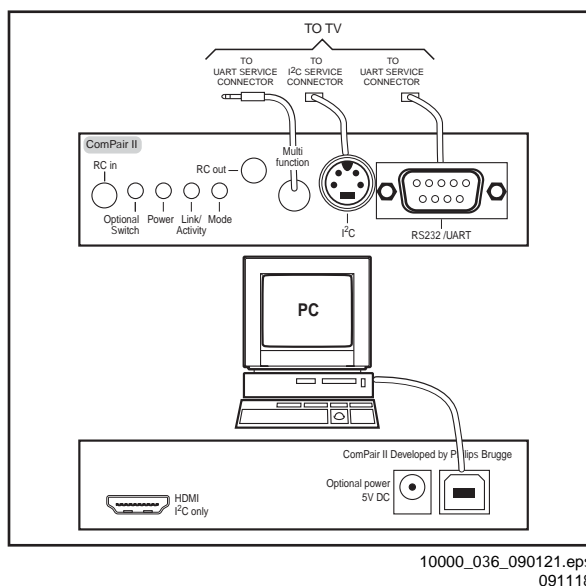

Figure 5-2 ComPair II interface connection

**Caution:** It is compulsory to connect the TV to the PC as shown in the picture above (with the ComPair interface in between), as the ComPair interface acts as a level shifter. If one connects the TV directly to the PC (via UART), ICs can be blown!

#### How to Order

ComPair II order codes:

- ComPair II interface: 3122 785 91020.
- Software is available via the Philips Service web portal.
- ComPair UART interface cable for TPM10.1x xx.  
(using DB9 to 2mm pitch JST connector): 3122 785 90630.

**Note:** When you encounter problems, contact your local support desk.

## 5.5 Software Upgrading

### 5.5.1 Description

It is possible for the user to upgrade the main software via the USB port. This allows replacement of a software image in a stand alone set. A description on how to upgrade the main software can be found in the DFU or on the Philips website.

### 5.5.2 Introduction

Philips continuously tries to improve its products, and it's recommend that the TV software is updated when updates are available. Software update files can be obtained from the dealer or can be downloaded from the following websites:  
<http://www.philips.com/support>

#### Preparing a portable memory for software upgrade

The following requirements have to be met:

1. A personal computer connected to the internet.
2. An archive utility that supports the ZIP-format (e.g. WinZip for Windows or Stuffit for Mac OS).
3. A FAT formatted USB memory stick (preferably empty).

#### Note:

1. Only FAT/DOS-formatted memory sticks are supported.
2. Only use software update files that can be found on the <http://www.philips.com/support> web site.

### 5.5.3 Check the current TV software version

Before starting the software upgrade procedure, it is advised to check that what the current TV software:

1. Press the "1 2 3 6 5 4" button on the remote control to enter the CSM mode.
2. Use the up/down cursor keys to select "Current Main Software".

If the current software version of the TV is the same as the latest update file found on <http://www.philips.com/support>, it is not necessary to update the TV software.

### 5.5.4 Download the latest software

1. Open the internet page <http://www.philips.com/support>.
2. Find information and software related to the TV.
3. Select the latest software update file and download it to the PC.
4. Insert the USB memory stick into one of the USB ports of the PC.
5. Decompress the downloaded ZIP file and copy the "autorun.upg" to the root directory of the USB flash drive.

### 5.5.5 Update the TV software

1. Turn the TV on and wait for it to boot completely.
2. Insert the USB memory stick that contains the software update files in one of the TV's USB ports.
3. The TV will detect the USB memory stick automatically. Then a window jumps out as [Figure 5-3](#).  
**Note:** If the USB flash drive is not detected after power up, disconnect it and re-insert it.
4. Select [Update] and press OK. See [Figure 5-3](#).
5. To proceed, In next menu select [Start] and press OK to start software updates. See [Figure 5-4](#).
6. Upgrading will now begins and the status of the updating progress will be displayed.
7. When the TV software is updated. Remove your USB flash drive, then select [Restart] and press OK to restart the TV. See [Figure 5-5](#).



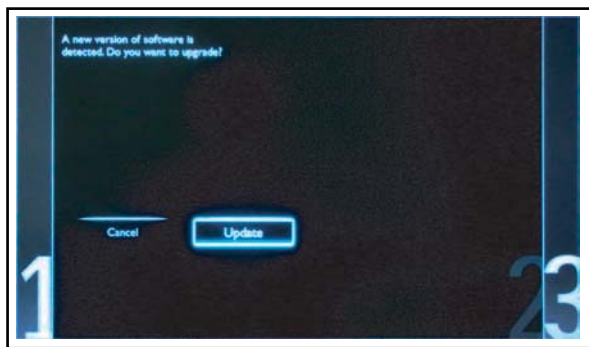

19080\_207\_110324.eps  
110324

Figure 5-3 Update the TV software [1/3]

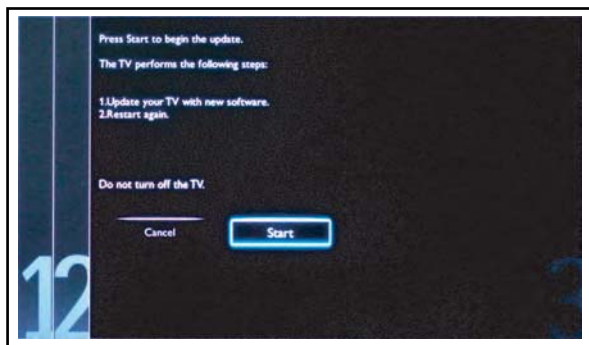

19080\_208\_110324.eps  
110324

Figure 5-4 Update the TV software [2/3]

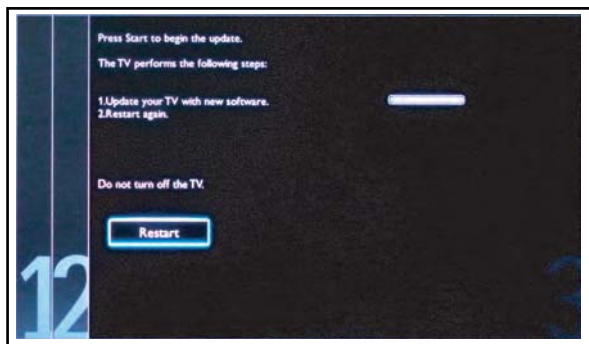

19080\_209\_110324.eps  
110324

Figure 5-5 Update the TV software [3/3]

**Note:**

- Do not remove the USB flash drive during the software update.
- If a power failure occurs during the update, do not remove the USB flash drive from the TV. The TV will continue the software update as soon as the power comes up again.
- If an error occurs during the update retry the procedure or contact the dealer.
- We do not recommend downgrading to an older version.
- Once the upgrade is finished, use the PC to remove the TV software from the USB portable memory.

**5.5.6 Content and Usage of the One-Zip Software File**

Below you find a content explanation of the One-Zip file, and instructions on how and when to use it. Only files that are relevant for Service are mentioned here.

- **EDID\_clustername.zip:** Contains the EDID content of the different EDID NVMs. See ComPair for further instructions.

- **FUS\_clustername\_version.zip:** Contains the "autorun.upg" which is needed to upgrade the TV main software and the software download application.
- **NVM\_clustername\_version.zip:** Default NVM content. Must be programmed via ComPair.

**5.5.7 How to Copy NVM Data to/from USB**

When copying data to and from a USB memory stick, the folder "repair" is used. When inserting an empty USB memory stick, and downloading data to the stick, the TV will create this folder. When sending data from a USB memory stick to a TV, the intended data must be available in the "repair" folder. Note that when copying EDID data to the TV, all necessary EDID files must be in this folder. Service mode overview for your reference.

**Table 5-3 Service mode overview**

Service Modes	Description
SAM	Service alignment mode
Factory Mode	Used for extended alignments
SDM	Service default Mode
CSM	3-page compact CSM pages. There will be CSM dump to USB-stick upon entering CSM-mode
USB SW upgradeable	SW-upgrading of flash memories MTK-chips MT5366 can be done via USB. The main SW can be upgraded via Autorun.upg
NVM-Editor in SAM	NVM-editor will function as in the past: Address and Value field is a decimal value via digit entry
Service Data	New Service data in SAM for CTN, Prod. no., 12NC programming with virtual keyboard
USB copy/paste in SAM	Channel list, NVM data, Readable info, EDID
UART logging	There will be printout available in UART. No specifications of the printout, per MTK provision/definition.
Blind SAM	RC sequence "062598" + "Menu" + "Panel code"
Clear Buffer	RC sequence "062599" + "OK" or via SAM

**5.6 Error Codes**

**5.6.1 Introduction**

Error codes are required to indicate failures in the TV set. In principle a unique error code is available for every:

- Activated (SW) protection.
- Failing I<sup>2</sup>C device.
- General I<sup>2</sup>C error.

The last five errors, stored in the NVM, are shown in the Service menu's. This is called the error buffer.

The error code buffer contains all errors detected since the last time the buffer was erased. The buffer is written from left to right. When an error occurs that is not yet in the error code buffer, it is displayed at the left side and all other errors shift one position to the right.

An error will be added to the buffer if this error differs from any error in the buffer. The last found error is displayed on the left. An error with a designated error code **never** leads to a deadlock situation. It must always be diagnosable (e.g. error buffer via OSD or blinking LED or via ComPair). In case a failure identified by an error code automatically results in other error codes (cause and effect), only the error code of the MAIN failure is displayed.

**5.6.2 How to Read the Error Buffer**

You can read the error buffer in three ways:

- On screen via the SAM/SDM/CSM (if you have a picture). Example:
  - **ERROR: 000 000 000 000 000:** No errors detected
  - **ERROR: 013 000 000 000 000:** Error code 13 is the last and only detected error



- **ERROR: 034 013 000 000 000:** Error code 13 was detected first and error code 34 is the last detected (newest) error
- Via the blinking LED procedure (when you have no picture). See paragraph [5.7 The Blinking LED Procedure](#).
- Via ComPair.

### 5.6.3 Error codes

In this chassis only “layer 2” error codes are available and point to problems on the SSB. They are triggered by LED blinking when CSM is activated. Only the following layer 2 errors are defined:

**Table 5-4 Error code table**

Layer-2 error code	Defective device
13	General I <sup>2</sup> C bus error on the SSB
16	+12 V missing or low, PSU defective
27	Channel decoder error on the SSB
34	Tuner I <sup>2</sup> C bus error on the SSB
35	EEPROM I <sup>2</sup> C error on SSB, M24C64

### 5.6.4 How to Clear the Error Buffer

The error code buffer is cleared in the following cases:

- By using the CLEAR command in the SAM menu
- By using the CLEAR command in the Factory mode:
- By using the following key sequence on the remote control transmitter: “**062599**” directly followed by the **OK** button.
- If the contents of the error buffer have not changed for 50 hours, the error buffer resets automatically.

**Note:** If you exit SAM by disconnecting the mains from the television set, the error buffer is not reset.

## 5.7 The Blinking LED Procedure

### 5.7.1 Introduction

The software is capable of identifying different kinds of errors. Because it is possible that more than one error can occur over time, an error buffer is available, which is capable of storing the last five errors that occurred. This is useful if the OSD is not working properly.

Errors can also be displayed by the blinking LED procedure. The method is to repeatedly let the front LED pulse with as many pulses as the error code number, followed by a period of 1.5 seconds in which the LED is “off”. Then this sequence is repeated.

**Example (1):** error code 4 will result in four times the sequence LED “on” for 0.25 seconds / LED “off” for 0.25 seconds. After this sequence, the LED will be “off” for 1.5 seconds. Any RC command terminates the sequence. Error code LED blinking is in red color.

**Example (2):** the content of the error buffer is “12 9 6 0 0” After entering SDM, the following occurs.

- 1 long blink of 5 seconds to start the sequence.
- 12 short blinks followed by a pause of 1.5 seconds.
- 9 short blinks followed by a pause of 1.5 seconds.
- 6 short blinks followed by a pause of 1.5 seconds.
- 1 long blink of 1.5 seconds to finish the sequence.
- The sequence starts again with 12 short blinks.

### 5.7.2 Displaying the Entire Error Buffer

Additionally, the entire error buffer is displayed LED when Service Mode “SDM” is entered.

## 5.8 Fault Finding and Repair Tips

### Note:

- It is assumed that the components are mounted correctly with correct values and no bad solder joints.
- Before any fault finding actions, check if the correct options are set.

### 5.8.1 NVM Editor

In some cases, it can be convenient if one directly can change the NVM contents. This can be done with the “NVM Editor” in SAM mode. With this option, single bytes can be changed.

### Caution:

- Do not change these, without understanding the function of each setting, because incorrect NVM settings may seriously hamper the correct functioning of the TV set!
- Always write down the existing NVM settings, before changing the settings. This will enable you to return to the original settings, if the new settings turn out to be incorrect.

### 5.8.2 Load Default NVM Values

It is possible to upload the default values to the NVM with ComPair in case the SW is changed, the NVM is replaced with a new (empty) one, or when the NVM content is corrupted. After replacing an EEPROM (or with a defective/no EEPROM), default settings should be used to enable the set to start-up and allow the Service Default Mode and Service Alignment Mode to be accessed.

### 5.8.3 No Picture

When you have no picture, first make sure you have entered the correct display code. See paragraph [6.4 Option Settings](#) for the instructions. See also [Table 6-3](#).

### 5.8.4 Unstable Picture via HDMI input

Check (via ComPair or factory mode) if HDMI EDID data is properly programmed.

### 5.8.5 No Picture via HDMI input

Check if HDCP key is valid. This can be done in CSM.

### 5.8.6 TV Will Not Start-up from Stand-by

Possible Stand-by Controller failure. Re-flash the software.

### 5.8.7 Audio Amplifier

The Class D-IC U606 has a powerpad for cooling. When the IC is replaced it must be ensured that the powerpad is very well pushed to the PWB while the solder is still liquid. This is needed to insure that the cooling is guaranteed, otherwise the Class D-IC could break down in short time.

### 5.8.8 CSM

When CSM is activated and there is a USB memory stick connected to the TV, the software will dump the complete CSM content to the USB memory stick. The file (Csm.txt) will be saved in the root of the USB memory stick.

### 5.8.9 Loudspeakers

Make sure that the volume is set to minimum during disconnecting the speakers in the ON-state of the TV. The audio amplifier can be damaged by disconnecting the speakers during ON-state of the set!

#### 5.8.10 Display option code

Attention: In case the SSB is replaced, always check the Panel Code in CSM, even when picture is available. Performance with the incorrect display option code can lead to unwanted side-effects for certain conditions.

## 6. Alignments(Optional)

### Index of this chapter:

[6.1 General Alignment Conditions](#)

[6.2 Hardware Alignments](#)

[6.3 Software Alignments](#)

[6.4 Option Settings](#)

[6.5 Reset of Repaired SSB](#)

### 6.1 General Alignment Conditions

Perform all electrical adjustments under the following conditions:

- Power supply voltage: 90 - 264 V<sub>AC</sub>, 50/ 60 ± 3 Hz.
- Connect the set to the mains via an isolation transformer with low internal resistance.
- Allow the set to warm up for approximately 15 minutes.
- Measure voltages and waveforms in relation to correct ground (e.g. measure audio signals in relation to AUDIO\_GND).

**CAUTION:** It is not allowed to use heat sinks as ground.

- Test probe: R<sub>i</sub> > 10 MW, C<sub>i</sub> < 20 pF.
- Use an isolated trimmer/screwdriver to perform alignments.

### 6.2 Hardware Alignments

Not applicable.

### 6.3 Software Alignments

Put the set in SAM mode (see Chapter 5. [Service Modes, Error Codes, and Fault Finding](#)). The SAM menu will now appear on the screen. Select RGB Align and go to one of the sub menus. The alignments are explained below.

The following items can be aligned:

- White point.

To store the data:

- Press OK on the RC **before the cursor is moved to the left**.
- Select "Store" and press OK on the RC.
- Switch the set to stand-by mode.

For the next alignments, supply the following test signals via a video generator to the RF input:

- **EU/AP-PAL models:** a PAL B/G TV-signal with a signal strength of at least 1 mV and a frequency of 475.25 MHz
- **US/AP-NTSC models:** an NTSC M/N TV-signal with a signal strength of at least 1 mV and a frequency of 61.25 MHz (channel 3).
- **LATAM models:** an NTSC M TV-signal with a signal strength of at least 1 mV and a frequency of 61.25 MHz (channel 3).

#### 6.3.1 RGB Alignment

Before alignment, set the picture as follows:

Picture Setting	
Dynamic backlight	Off
Dynamic Contrast	Off
Color Enhancement	Off
Picture Format	Unscaled
Light Sensor	Off
Brightness	50
Color	0
Contrast	100

#### White Tone Alignment:

- Activate SAM.
- Select "RGB Align." and choose a color temperature.
- Use a 100% white screen as input signal and set the following values:
  - "Red BL Offset" and "Green BL Offset" to "7" (if present).
  - All "White point" values initial to "128".

In case you have a colour analyser:

- Measure with a calibrated (phosphor- independent) color analyser (e.g. Minolta CA-210) in the centre of the screen. Consequently, the measurement needs to be done in a dark environment.
- Adjust the correct x, y coordinates (while holding one of the White point registers R, G or B on max. value) by means of decreasing the value of one or two other white points to the correct x, y coordinates (see [Table 6-1 White D alignment values](#)). Tolerance: dx: ± 0.003, dy: ± 0.003.
- Repeat this step for the other colour Temperatures that need to be aligned.
- When finished return to the SAM root menu and press STANDBY on the RC to store the aligned values to the NVM.

**Table 6-1 White D alignment values**

Value	Cool (12000 K)	Normal (9000 K)	Warm (6500 K)
x	0.276	0.287	0.313
y	0.282	0.296	0.329

If you do **not** have a colour analyser, you can use the default values. This is the next best solution. The default values are average values coming from production (statistics).

#### 6.3.2 Display Adjustment

You can use the default values. The default values are average values coming from production.

- Enter SAM mode.
- Select a colour temperature (e.g. COOL, NORMAL, or WARM).
- Set the RED, GREEN and BLUE default values according to the values in [Table 6-2](#).
- When finished press OK on the RC, then press STORE to store the aligned values to the NVM.
- Restore the initial picture settings after the alignments.

**Table 6-2 White tone default settings**

Picture mode	Screen size	Colour temperature		
		Red	Green	Blue
Normal (9000K)	32PFL30x8			
	39PFL3008			
	42PFL3008			
Cool (11000K)	32PFL30x8			
	39PFL3008			
	42PFL3008			
Warm (6500K)	32PFL30x8			
	39PFL3008			
	42PFL3008			

This group setting of colour temperature will be applied automatically to the TV / VGA / HDMI / AV sources.

## 6.4 Option Settings

### 6.4.1 Introduction

The microprocessor communicates with a large number of I<sup>2</sup>C ICs in the set. To ensure good communication and to make digital diagnosis possible, the microprocessor has to know which ICs to address. The presence / absence of these MT5366 ICs is made known by the option codes.

#### Notes:

- After changing the option(s), save them by pressing the OK button on the RC before the cursor is moved to the left, select STORE and press OK on the RC.
- The new option setting is only active after the TV is switched "off" / "stand-by" and "on" again with the mains switch (the NVM is then read again).

### 6.4.2 Option Code Overview

Enter SAM mode to check the option codes. they could not be edited in the NVM.

### 6.4.3 Display Code Overview

Press the following key sequence on a standard RC transmitter: "062598" directly followed by MENU and "xxx", where "xxx" is a 3 digit decimal value of the panel type: see column "Display Code" in [Table 6-3](#). After resetting the Display Code, restart the set immediately.

**Table 6-3 Display code overview**

CTN_ALT BOM#	Panel Type	Display Code
32PFL30x8	TPT315B5-A051	
39PFL3008	TPT390J1-HVN01	
42PFL3008	TPT420H2-HVN04	

## 6.5 Reset of Repaired SSB

A very important issue towards a repaired SSB from a Service repair shop (SSB repair on component level) implies the reset of the NVM on the SSB.

A repaired SSB in Service should get the service Set type "00PF0000000000" and Production code "00000000000000". Also the virgin bit is to be set. To set all this, you can use the ComPair tool or use the "NVM editor" and "Dealer options" items in SAM (do not forget to "store").

After a repaired SSB has been mounted in the set (set repair on board level), the type number (CTN) and production code of the TV has to be set according to the type plate of the set. For this, you can use the NVM editor in SAM. The loading of the CTN and production code can also be done via ComPair (Model number programming).

In case of a display replacement, reset the "Operation hours display" to "0", or to the operation hours of the replacement display.

#### Remark:

- After the NVM has been replaced, go to SAM and scroll to the <Reload MAC address> (see figure 1\*).
- Select the item and press <OK> on the RC.

### 6.5.1 Reset of Repaired SSB

#### Instruction

After NVM replacement, reload MAC address via SAM menu. This ensures the correct MAC address to be available in CSM for future repair actions.

#### Way of working:

- After the NVM has been replaced, go to SAM and scroll to the <Reload MAC address> .
- Select the item and press <OK> on the RC.

#### Notes:

- Only applicable to all related models that are "Smart TV level 0" enabled (only YouTube access). For models without internet connection feature, **no action** is needed.
- HDCP keys are located in the NVM. If you are loading NVM with the ComPair tool, there is warning message displayed.

New NVM EEPROMs are shipped with pre-loaded HDCP keys.

### 6.5.2 SSB Identification

SSB's of this chassis are identified by a "715" code on the SSB. 715Axxxx-Nnn-MMM-O000

- **715** main category, Printed Wiring Board
- **Axxxx** sub category, sequential coding number
- **Nnn** Version code
  - **N** Development number
  - **nn** Production number
- **MMM** Mounting variation code
- **O000** Optional variation code

Make sure when replacing an SSB the SSB identification codes match the replacement panel.

## 7. Circuit Descriptions

### Index of this chapter:

[7.1 Introduction](#)

[7.2 Power Supply](#)

[7.3 DC/DC Converters](#)

[7.4 Front-End Analogue and DVB-T, DVB-C reception](#)

### Notes:

- Only **new** circuits (circuits that are not published recently) are described.
- Figures can deviate slightly from the actual situation, due to different set executions.
- For a good understanding of the following circuit descriptions, please use the wiring block (see chapter [9. Block Diagrams](#)) and circuit diagrams (see chapter [10. Circuit Diagrams and PWB Layouts](#)). Where necessary, you will find a separate drawing for clarification.

### 7.1 Introduction

The TPS10.1L LA is a new chassis launched in LATAM in 2013. The whole range is covered by SCALER MST6931. The major deltas versus its predecessor support ATV, DTV; with also multi-media, ARC, CEC functionality.

The TPS10.1L LA chassis comes with the following stylings:

- series xxPFL30x8D

#### 7.1.1 Implementation

Key components of this chassis are:

- SCALER MST6931XP-SW EPLQFP-128
- TUNER LATAM TDST-H030F
- IC TPA3110D2 15W TSSOP-28 for Audio Amplifier
- AUDIO APA2176AQBTRG 0.27W TQFN3X3-16 for headphone AMP
- DEMODULATOR MSB1400LQFP for DTV Demod

#### 7.1.2 TPS10.1L LA Architecture Overview

For details about the chassis block diagrams refer to [Figure 9.4](#).

7.1.3 SSB Cell Layout

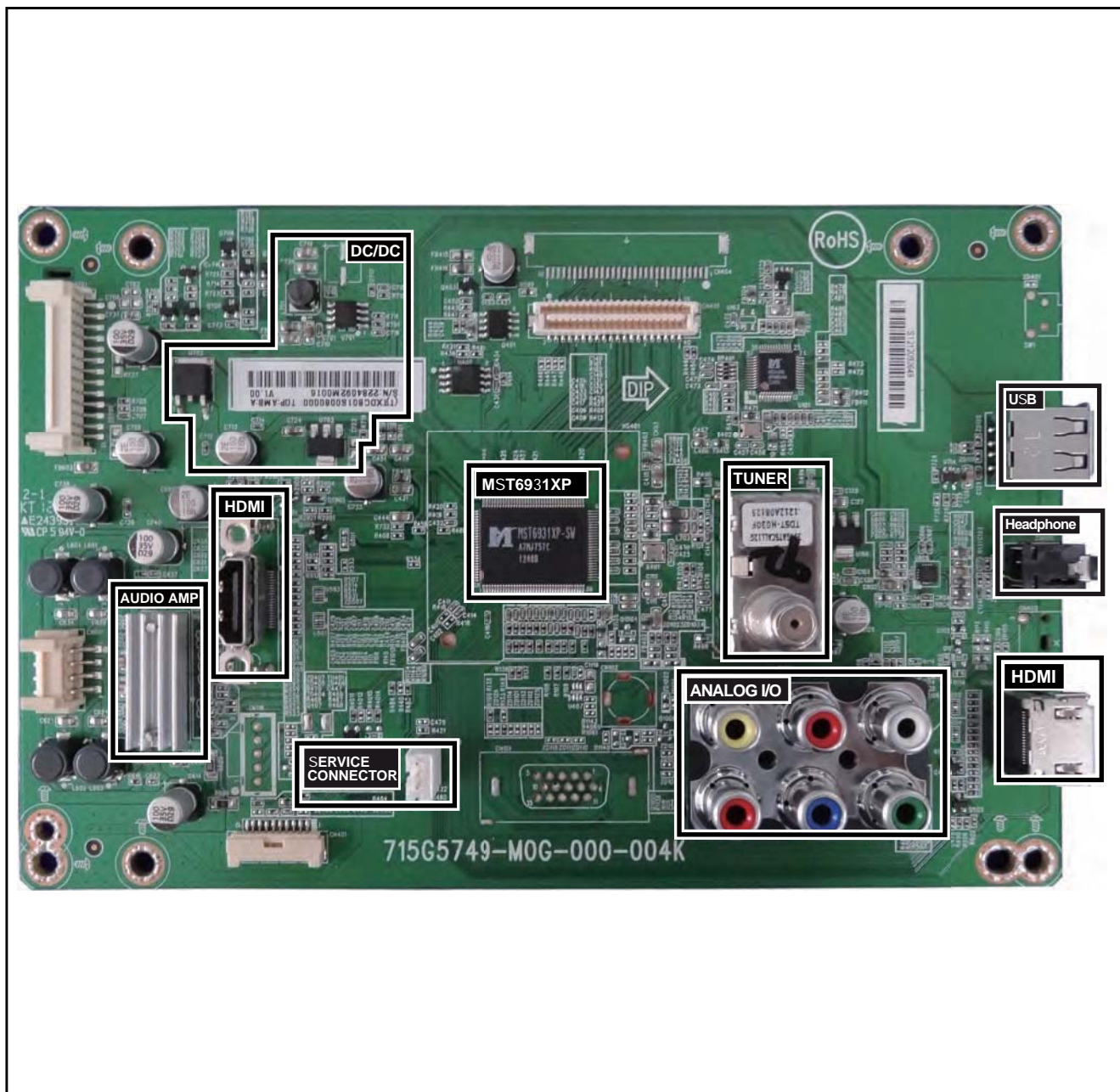

19500\_200\_130415.eps  
130415

Figure 7-1 SSB layout cells (top view)



## 7.2 Power Supply

Refer to figure [Figure 7-2](#) for the power architecture of this platform.

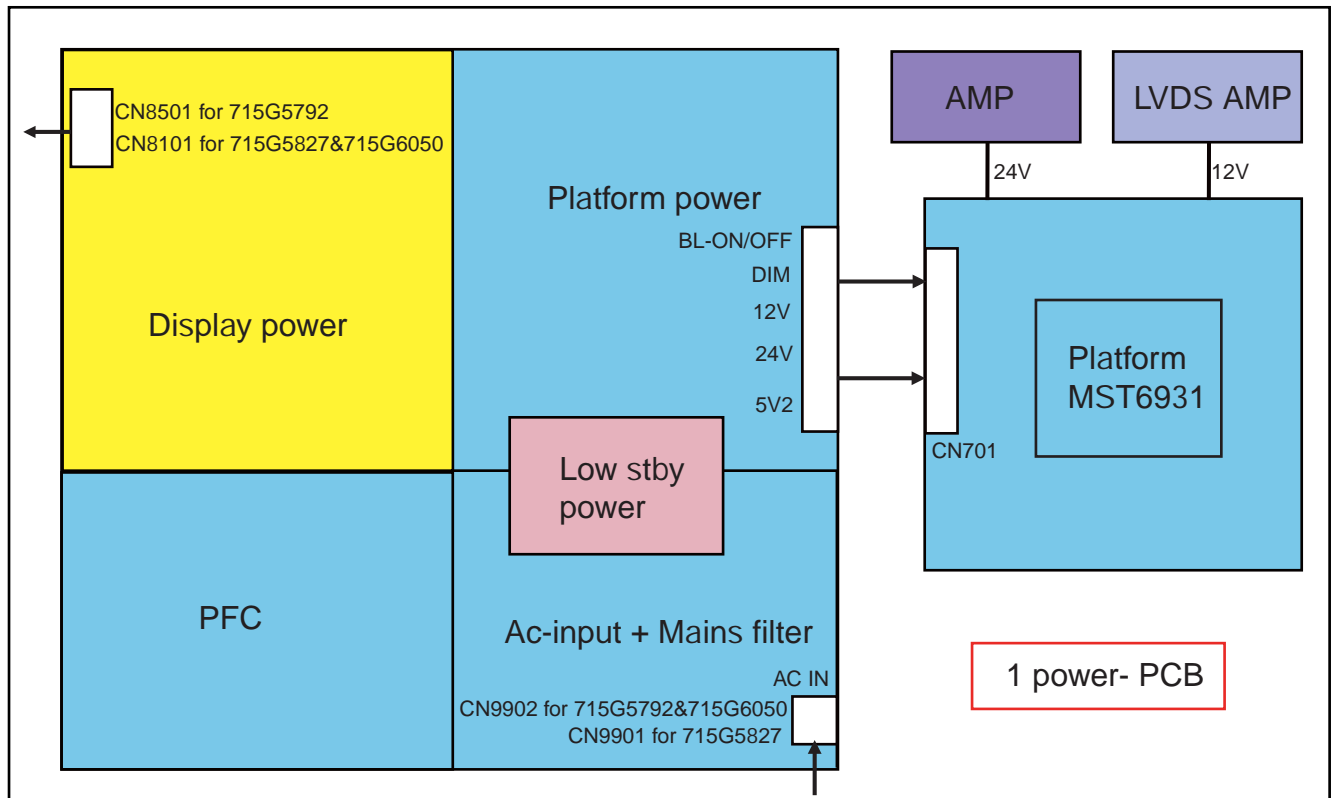

19500\_201\_130416.eps  
130416

Figure 7-2 Power Architecture

### 7.2.1 Power Supply Unit

All power supplies are a black box for Service. When defective, a new panel must be ordered and the defective one must be returned, unless the main fuse of the panel is broken. Always replace a defective fuse with one with the correct specifications! This part is available in the regular market. Consult the Philips Service web portal for the order codes of the panels.

Important delta's with the TPS10.L LA classis platform are:

- New power architecture for LED backlight
- "Boost"-signal is now a PWM-signal + continuous variable.

The control signals are:

- Stand-by
- Inverter "on/off"
- DIM (PWM) (not for PSDL)

In this manual, no detailed information is available because of design protection issues.

The output voltages to the chassis are:

- +4V7-STANDBY (Stand-by mode only)
- +12V (on-mode)
- +Vsnd (+24V) (audio power) (on-mode)
- +24V (bolt-on power) (on-mode)
- Output to the display; in case of
  - IPB: High voltage to the LCD panel
  - PSL and PSLs (LED-driver outputs)
  - PSDL (high frequent) AC-current.

### 7.2.2 Diversity

The diversity in power supply units is mainly determined by the diversity in displays.

The following displays can be distinguished:

- CCFL/EEFL backlight: power panel is conventional IPB
- LED backlight:
  - side-view LED without scanning: PSL power panel
  - side-view LED with scanning: PSLs power panel
  - direct-view LED without 2D-dimming: PSL power panel
  - direct-view LED with 2D-dimming: PSDL power panel.

**PSL** stands for **Power Supply** with integrated LED-drivers.

**PSLS** stands for a **Power Supply** with integrated LED-drivers with added **Scanning** functionality (added microcontroller).

**PSDL** stands for a **Power Supply** for **Direct-view LED** backlight with 2D-dimming.

### 7.2.3 Connector overview

Table 7-1 Connector overview

Number	Connector					
	CN8101	CN9101	CN8101	CN9101	CN8501	CN9101
Description	to panel	to SSB	to panel	to SSB	to panel	to SSB
Pin	12	13	12	13	12	13
1	VLED	n.c.	VLED	n.c.	VLED	n.c.
2	n.c.	+5.2V	n.c.	+5.2V	n.c.	+5.2V
3	LED1	+5.2V	LED1	+5.2V	LED6	+5.2V
4	LED1	PS_ON	LED1	PS_ON	LED5	PS_ON
5	LED1	+12V	LED1	+24V	LED4	+24V
6	n.c.	+12V	LED1	+24V	n.c.	+24V
7	n.c.	GND	LED1	GND	n.c.	GND

Number	Connector					
	CN8101		CN9101		CN9101	
	to panel	to SSB	to panel	to SSB	to panel	to SSB
8	n.c.	GND	LED1	GND	LED3	GND
9	-	GND	LED1	GND	LED2	GND
10	-	+12V	LED1	+12V	LED1	+12V
11	-	+12V	n.c.	+12V	n.c.	+12V
12	-	DIM	VLED	DIM	VLED	DIM
13	-	ON/OFF	-	ON/OFF	-	ON/OFF

- +3V3-STANDBY, power supply for LED/IR receiver and controls
- +12V, input from the power supply for the panel common(active mode)
- +24V, input from the power supply for the AMP
- +1V2, from the power supply for the scaler IC MST6931
- +1V8, supply voltage for MST6931 DDR POWER
- +3V3, general supply voltage
- +3V3-TUN, supply voltage for tuner
- +5V normal supply voltage for headphone AMP
- +5V-USB, input intermediate supply voltage for the USB Power
- +3V3 from the power supply for the scaler IC MST6931

**7.3 DC/DC Converters**

The on-board DC/DC converters deliver the following voltages (depending on set execution):

- +5V-STANDBY, permanent voltage for the Stand-by controller

Figures gives a graphical representation of the DC/DC converters with its current consumptions:

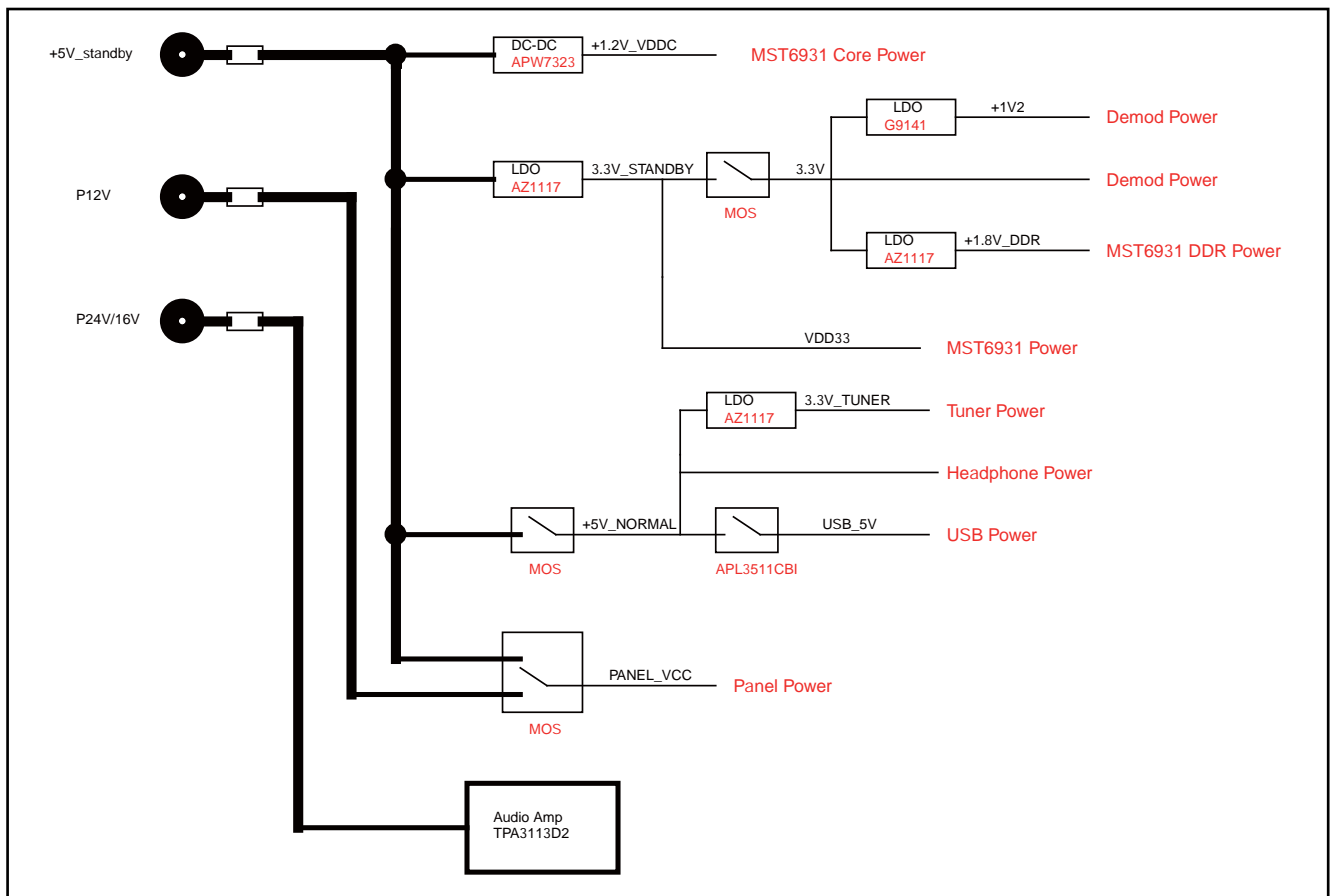

19500\_202\_130416.eps  
130416

Figure 7-3 DC/DC converters

**7.4 Front-End Analogue and DVB-T, DVB-C reception**

**7.4.1 Front-End Analogue part**

The Front-End for analogue tuner consist of the following key components:

- TUNER LATAM TDST-H030F
- SCALER MST6931XP-SW EPLQFP-128

Below find a block diagram of the front-end application for analogue part.

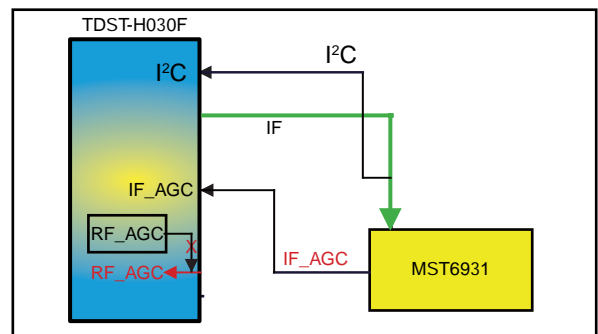

19500\_203\_130416.eps  
130416

Figure 7-4 Front-End DVB-T/C DTV block diagram

### 7.4.2 Front-End DTV part

The Front-End for DVB part consist of the following key components:

- TUNER LATAM TDST-H030F
- SCALER MST6931XP-SW EPLQFP-128

Below find a block diagram of the front-end application for DVB part.

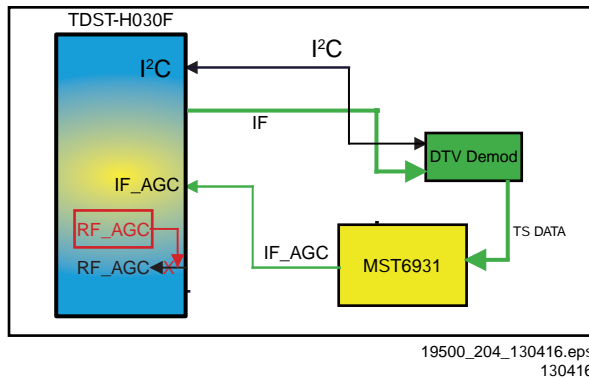

Figure 7-5 Front-End DVB-T2 DTV block diagram

### 7.5 HDMI

Refer to figure [7-6 HDMI input configuration](#) for the application.

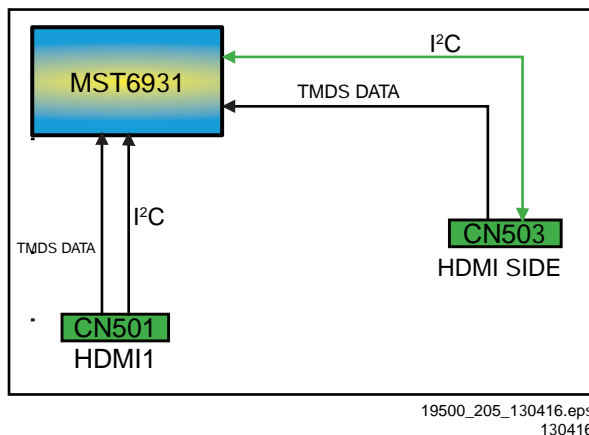

Figure 7-6 HDMI input configuration

The HDMI connector has the following specifications:

- +5V detection mechanism
- Stable clock detection mechanism
- Integrated EDID
- HPD control
- Sync detection
- TMDS output control
- CEC control

### 7.6 Video and Audio Processing - MST6931XP

The MST6931XP is the main audio and video processor (or System-on-Chip) for this platform. It has the following features:

- Multi-standard digital video decoder (MPEG-2, H.264, MPEG-4)
- Integrated DVB-T/DVB-C/DVB-S channel decoder
- Integrated motion accurate picture processing
- High definition ME/MC
- Extended colour gamut and colour booster
- Integrated USB2.0 host controller
- Multi-Standard TV Sound Processor
- High Performance Micro-processor

- RealMedia Decoder

The MST6931XP combines front-end video processing functions, such as NTSC/PAL/SECAM Video Decoder, MPEG-2/H.264 decode, analog video decode and HDMI reception, with advanced back-end video picture improvements. It also includes next generation Motion Accurate Picture Prscsing.High flat panel screen resolutions and refresh rates are supported with formats including 1280 x 720 @ 60Hz and 1920 x 1080 @ 60Hz. On top of that, optional support is available for 2D dimming in combination with LED backlights for optimum contrast and power savings up to 50%.

For a functional diagram of the MST6931XP, refer to [Figure 8-3](#).

## 8. IC Data Sheets

This chapter shows the internal block diagrams and pin configurations of ICs that are drawn as “black boxes” in the electrical diagrams (with the exception of “memory” and “logic” ICs).

### 8.1 Diagram 10-4-2 MST6931XP/SPI FLASH, B02, MST6931XP/SPI FLASH(IC U401)

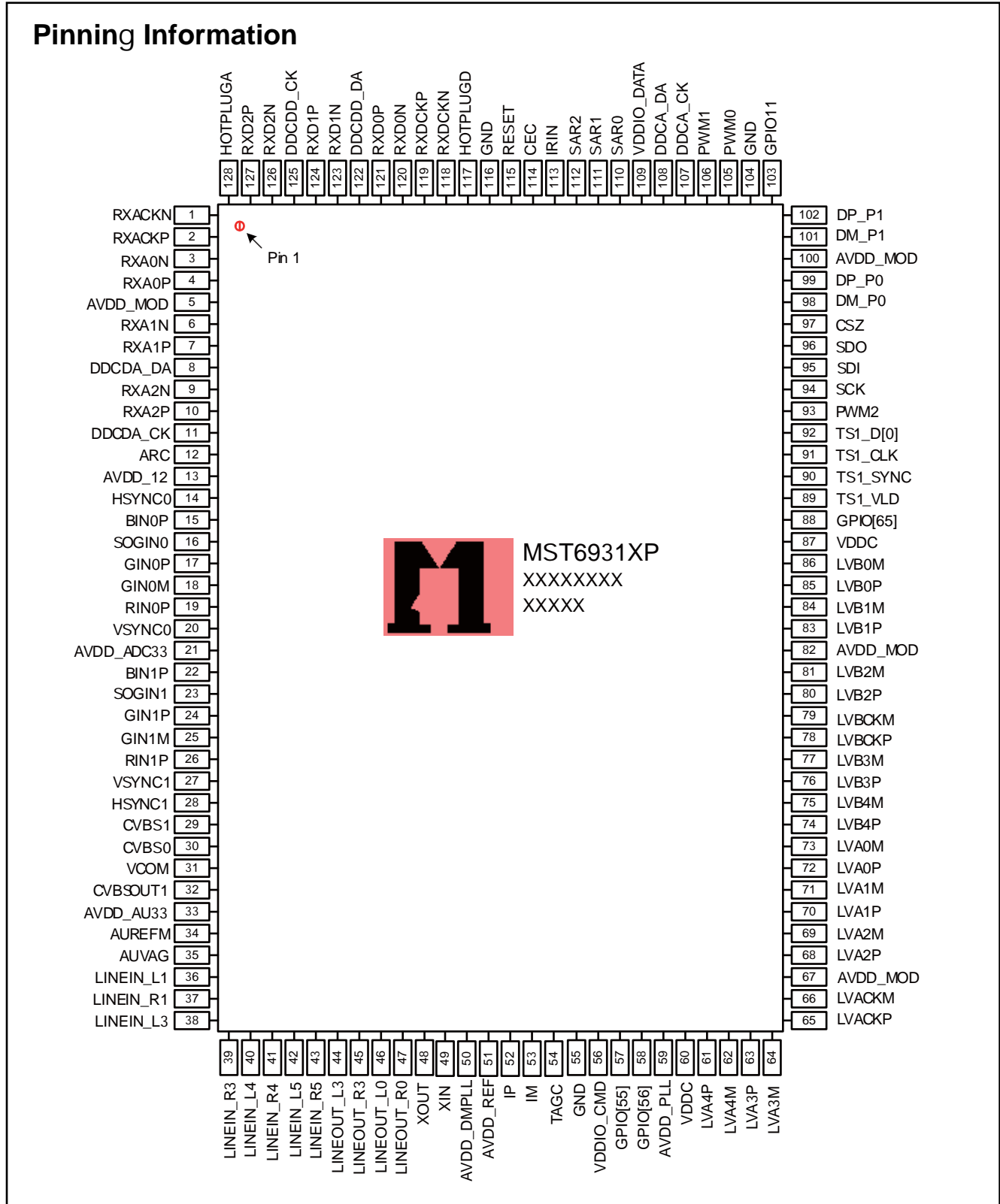

19450\_300\_130116.eps  
130116

Figure 8-1 Internal pin configuration

8.2 Diagram [10-4-8 MSB1400 Demod](#), B08, MSB1400 Demod(IC U101)

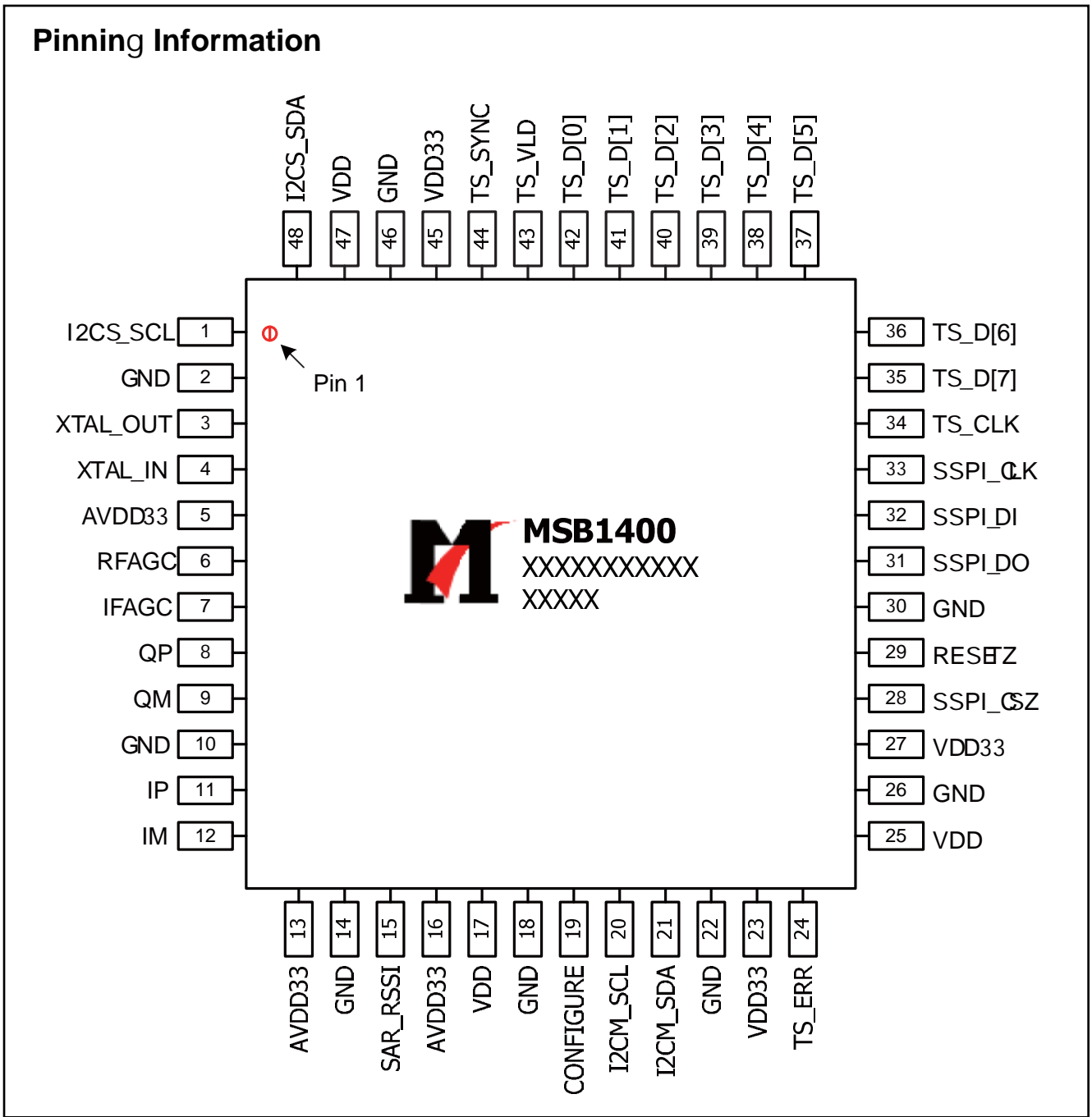

19500\_300\_130409.eps  
130409

Figure 8-2 Internal pin configuration



8.3 Diagram [10-4-10 Earphone pre amp, B10, APA2176A\(IC U606\)](#)

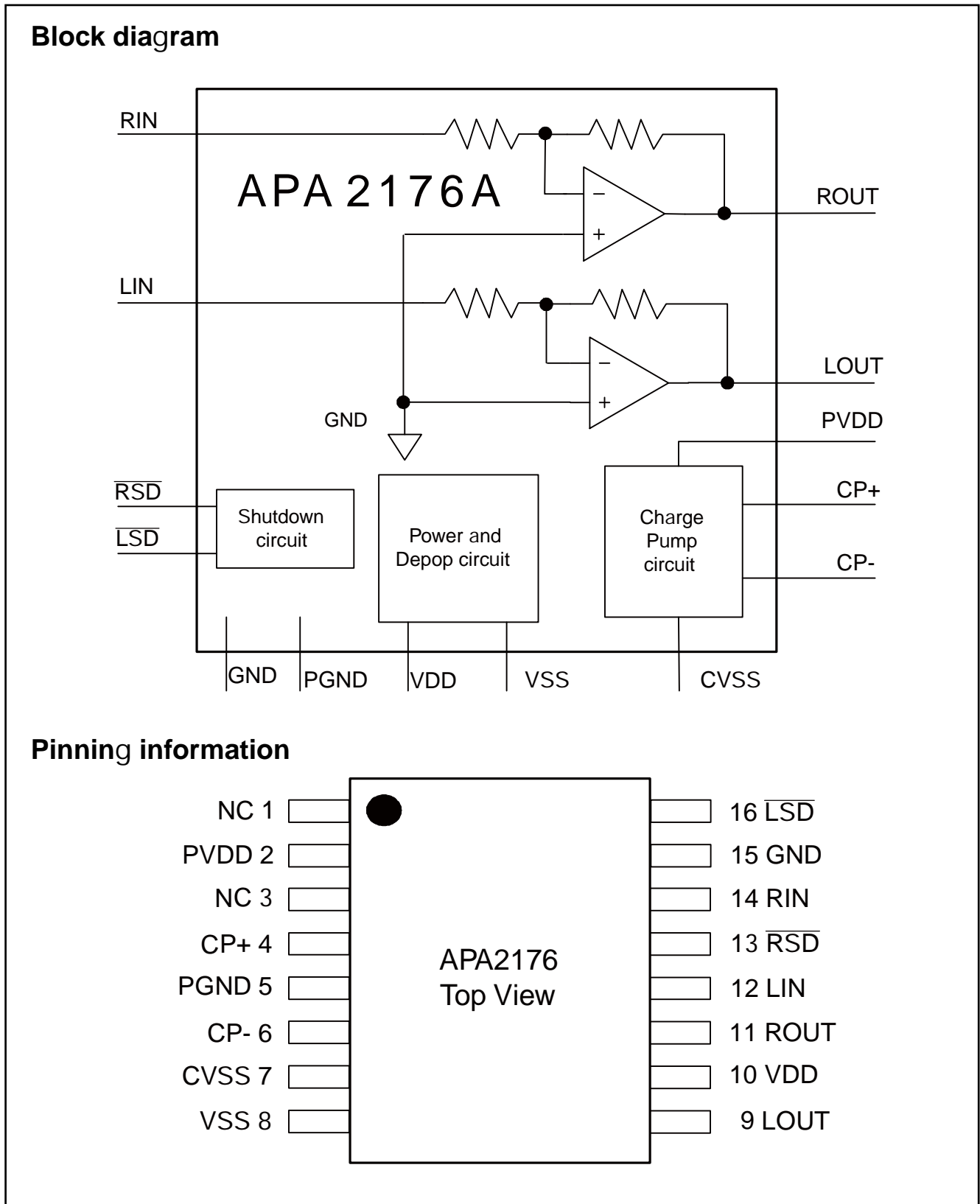

19450\_301\_130116.eps  
130116

Figure 8-3 Internal block diagram and pin configuration

## 9. Block Diagrams

9.1 Wiring diagram 3000 series 32"

WIRING DIAGRAM 32" (3000 series)

See note in Chapter 7 about cable position numbers

- Board Level Repair
- Component Level Repair  
Only for authorized workshops

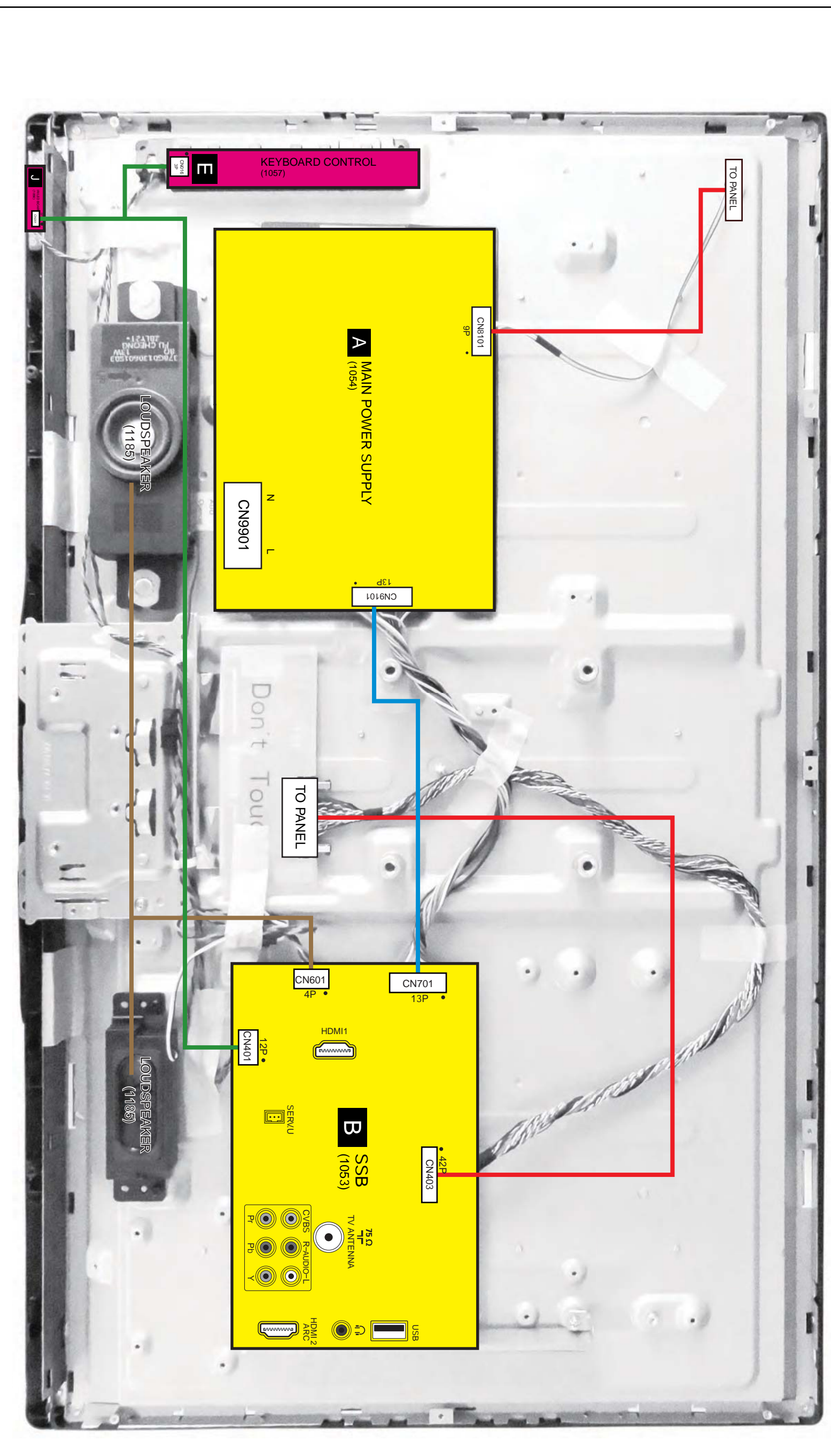

See note in Chapter 7 about cable position numbers

- Board Level Repair
- Component Level Repair  
Only for authorized workshops

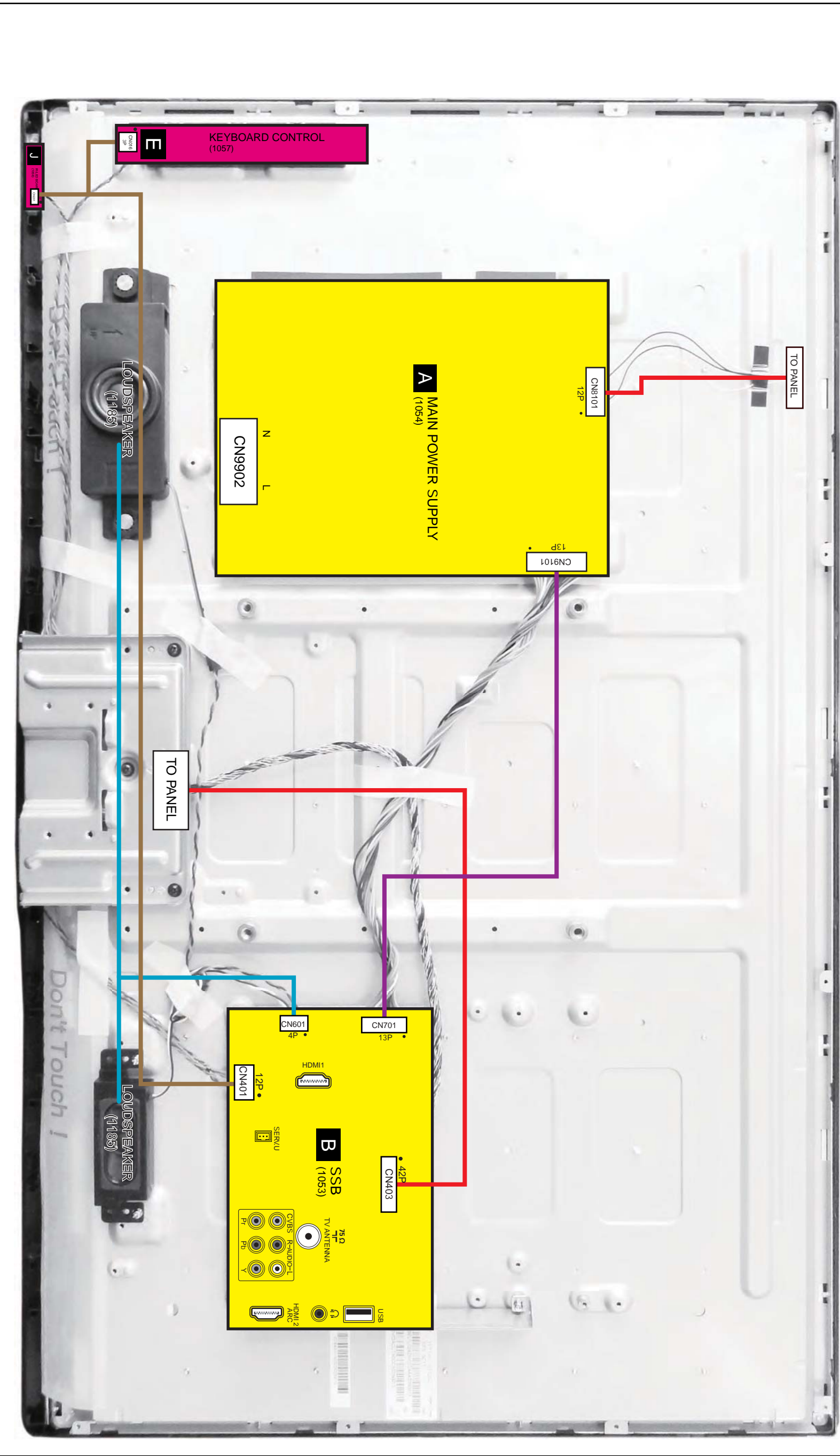



- Board Level Repair
- Component Level Repair  
Only for authorized workshops

See note in Chapter 7 about cable position numbers



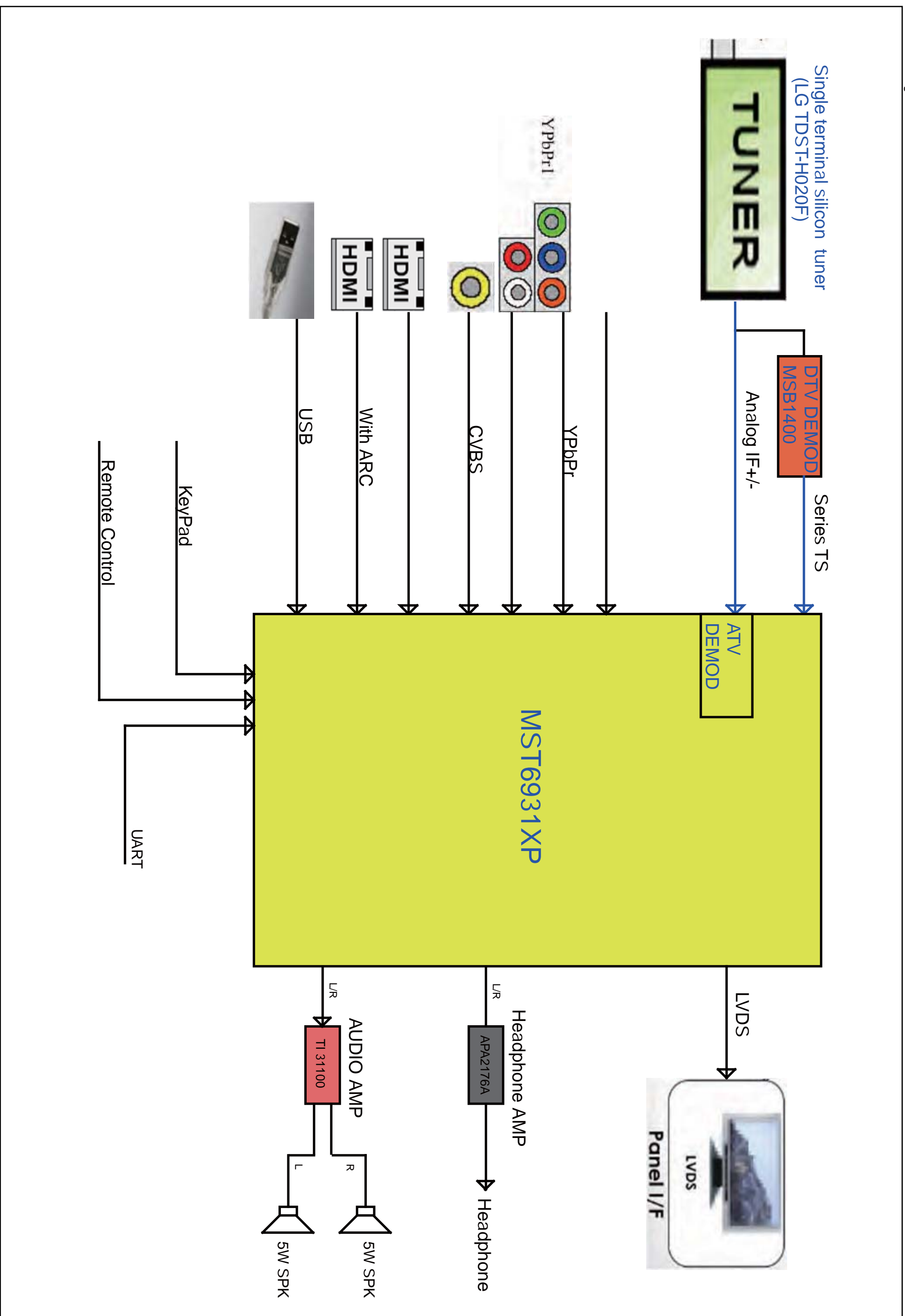

# 10. Circuit Diagrams and PWB Layouts

10.1 A715G5827 PSU  
10-1-1 Power

**A01**

Power

**A01**

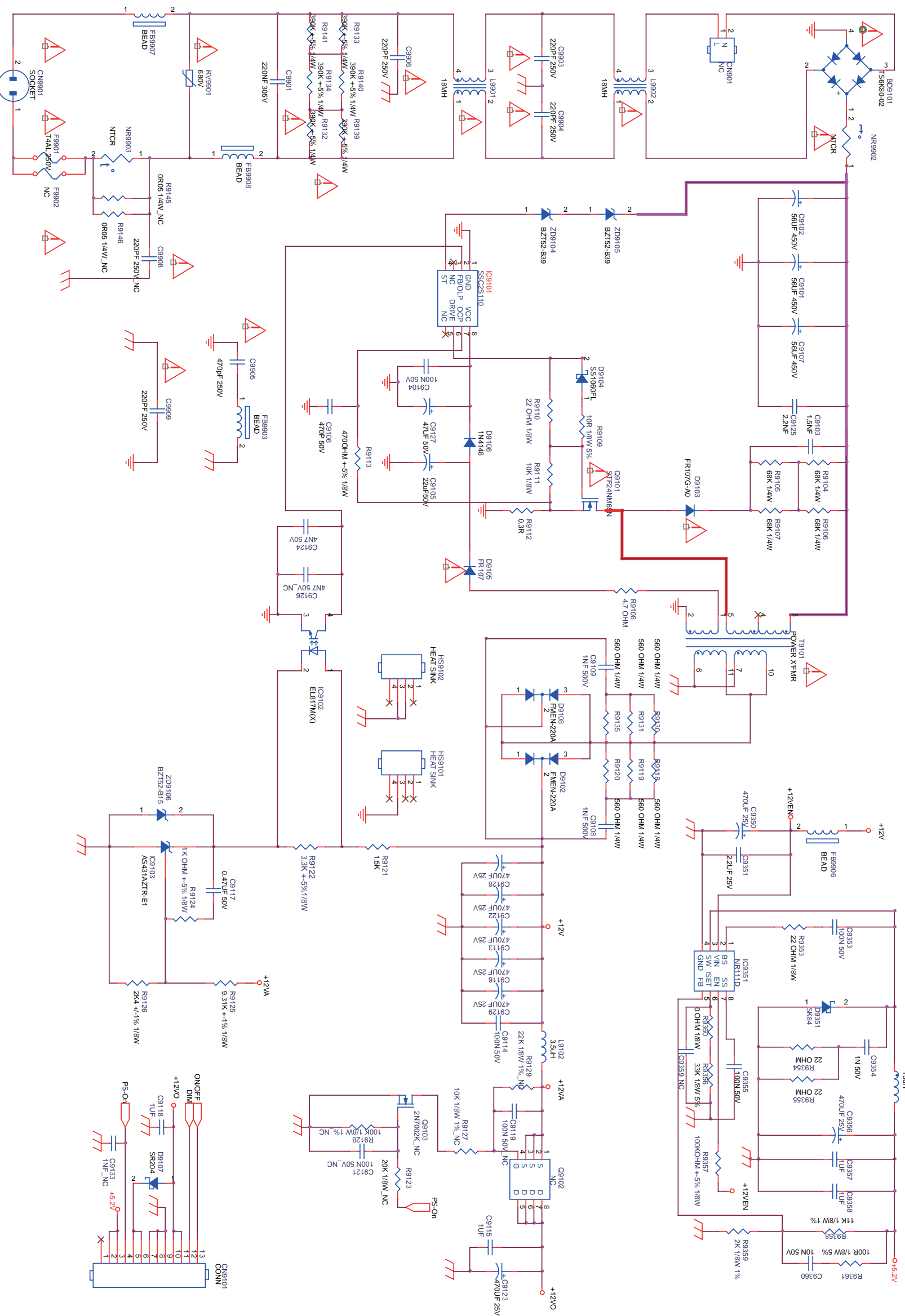

Rev	Description	Date
1	Initial Release	2013-04-26

Power

715G5827



**A02** LED DRIVER

**A02**

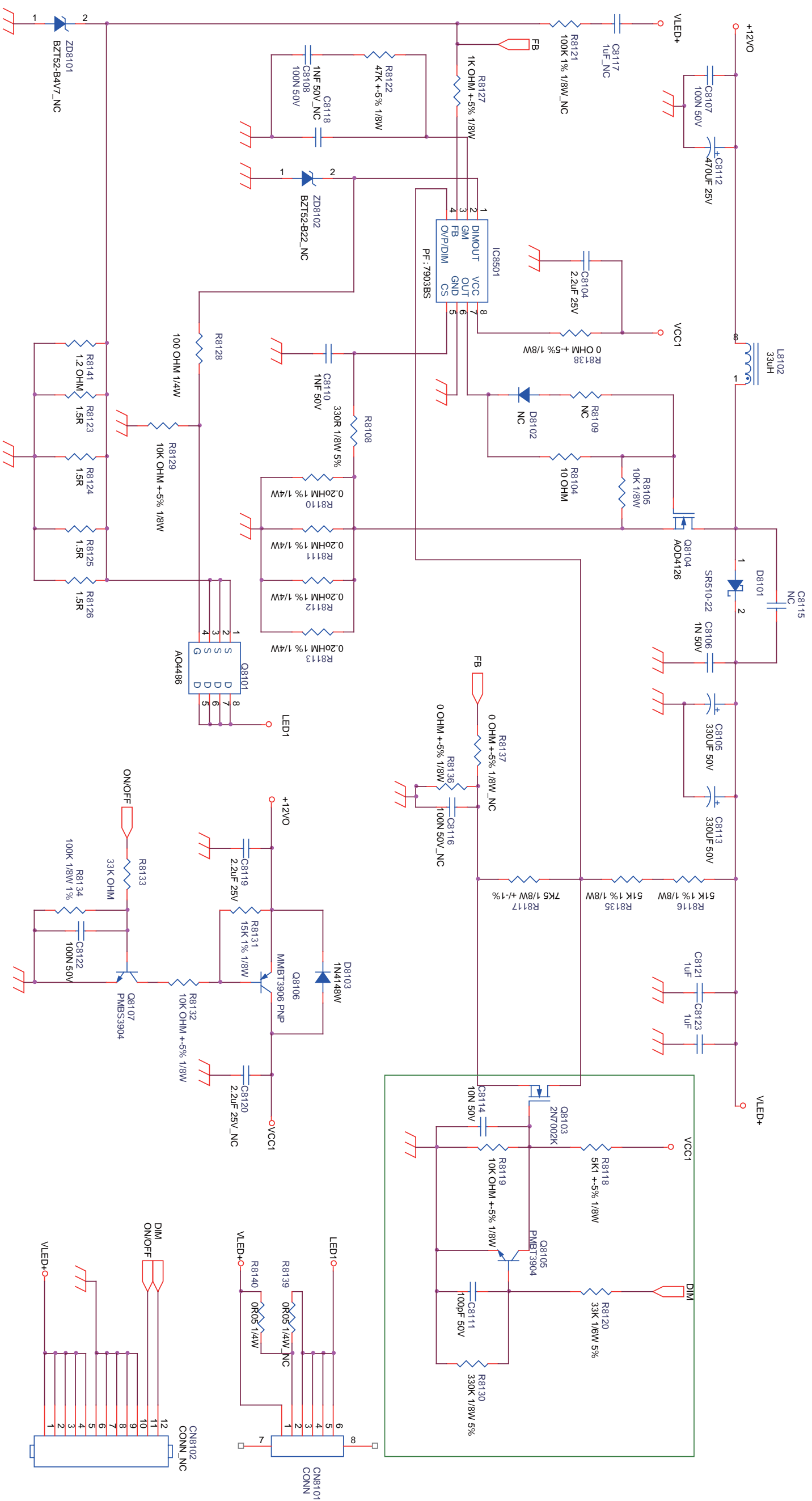

LED DRIVER	715G5827
1	20130408
2	130408
3	
4	
5	
6	
7	
8	
9	
10	
11	
12	

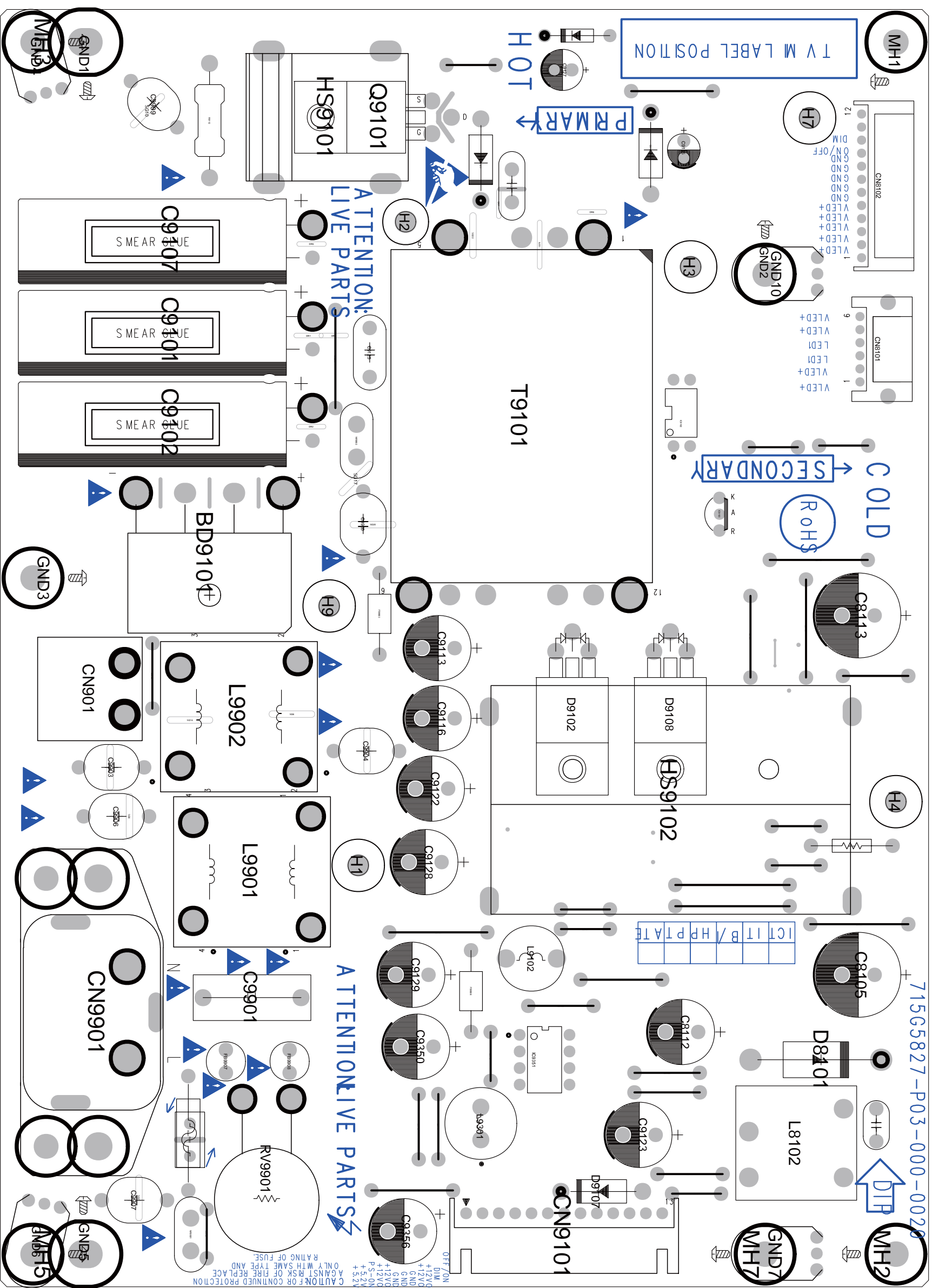

Power layout top	715G5827	1	2013-04-26
		2	
		3	
		4	
		5	
		6	
		7	
		8	
		9	
		10	
		11	
		12	
		13	
		14	
		15	
		16	
		17	
		18	
		19	
		20	
		21	
		22	
		23	
		24	
		25	
		26	
		27	
		28	
		29	
		30	
		31	
		32	
		33	
		34	
		35	
		36	
		37	
		38	
		39	
		40	
		41	
		42	
		43	
		44	
		45	
		46	
		47	
		48	
		49	
		50	
		51	
		52	
		53	
		54	
		55	
		56	
		57	
		58	
		59	
		60	
		61	
		62	
		63	
		64	
		65	
		66	
		67	
		68	
		69	
		70	
		71	
		72	
		73	
		74	
		75	
		76	
		77	
		78	
		79	
		80	
		81	
		82	
		83	
		84	
		85	
		86	
		87	
		88	
		89	
		90	
		91	
		92	
		93	
		94	
		95	
		96	
		97	
		98	
		99	
		100	

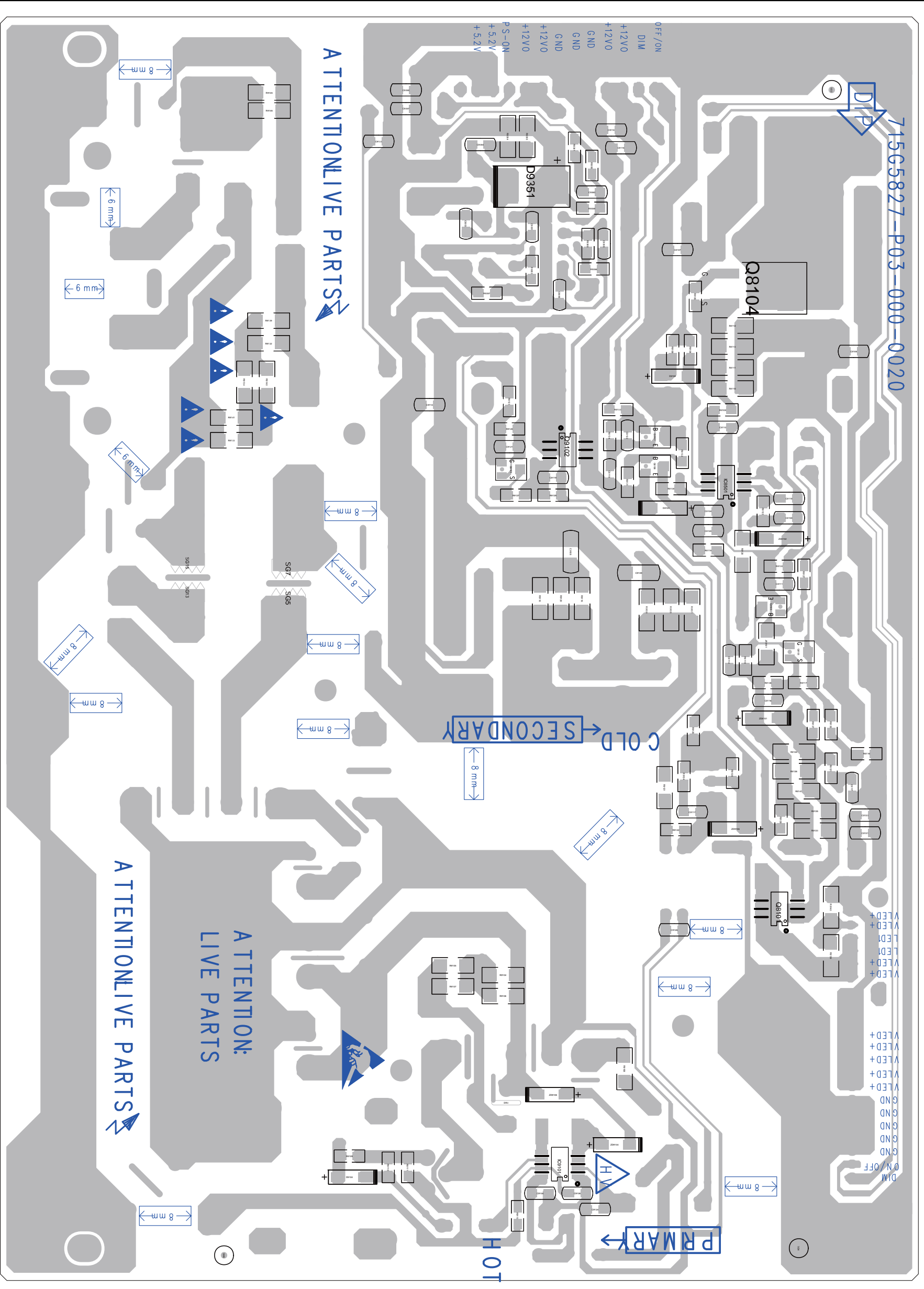

**A01**

AC Input

**A01**

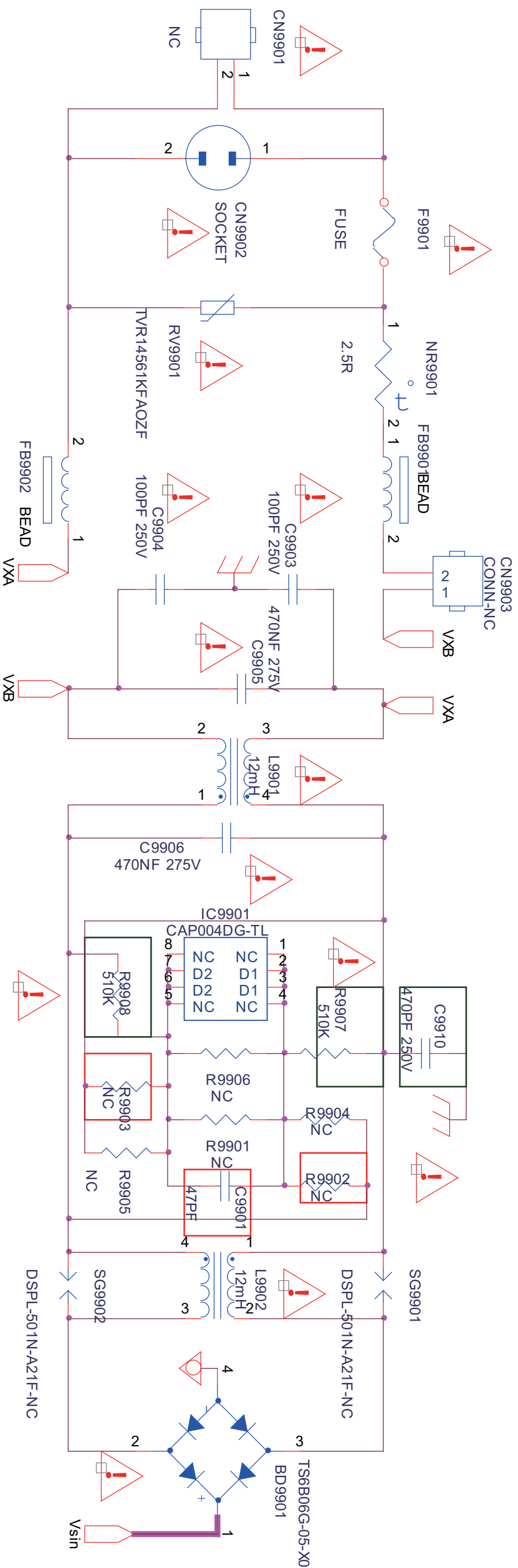

AC Input	715G5792
19430_504_130114.eps	130114

**A02**

PFC

**A02**

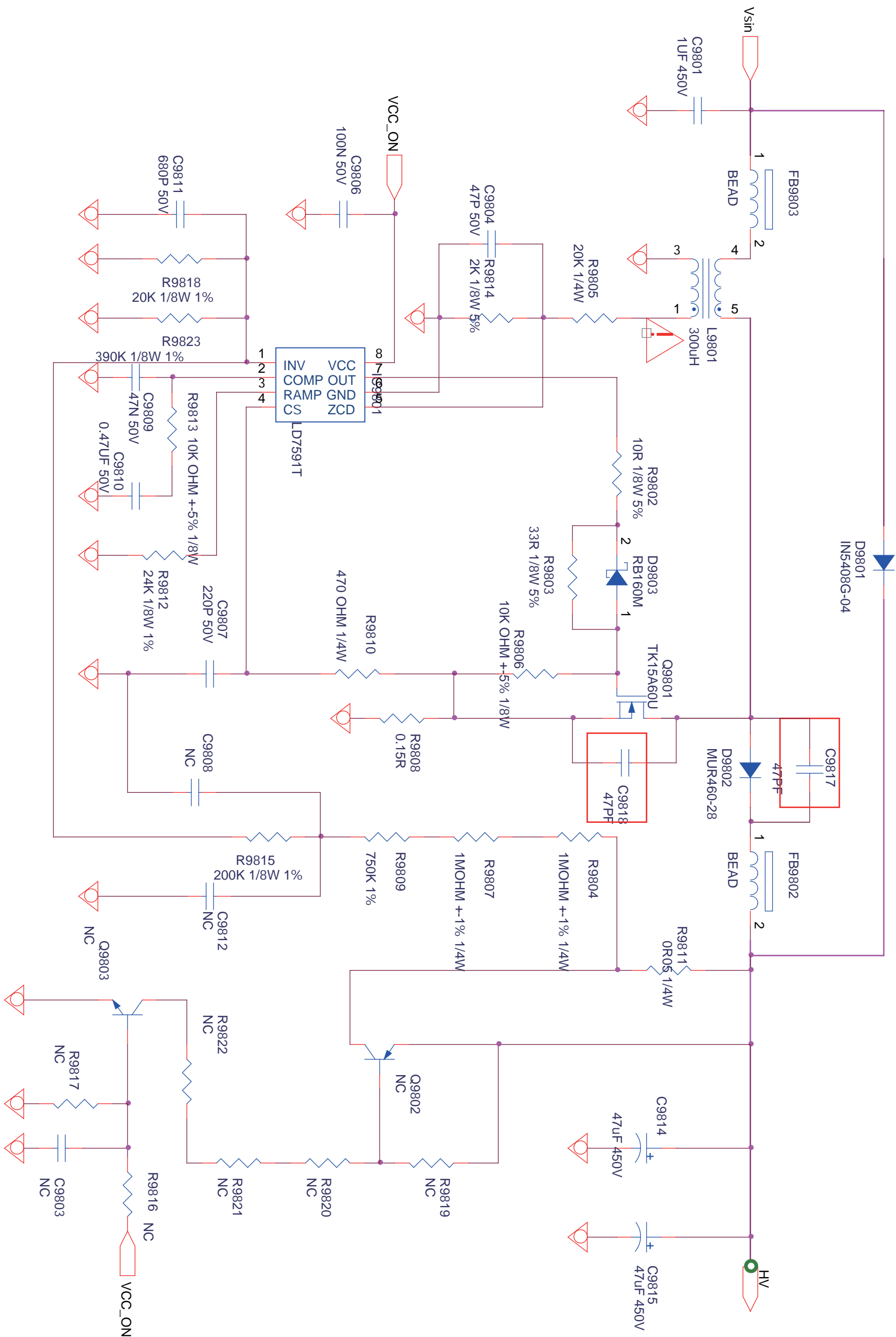

PFC	715G5792	1	2013-04-26
			div/valde

A03

Main Power

A03

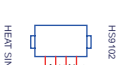
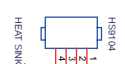
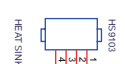
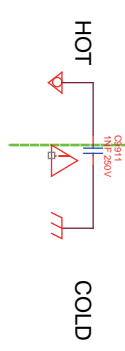
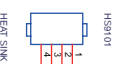
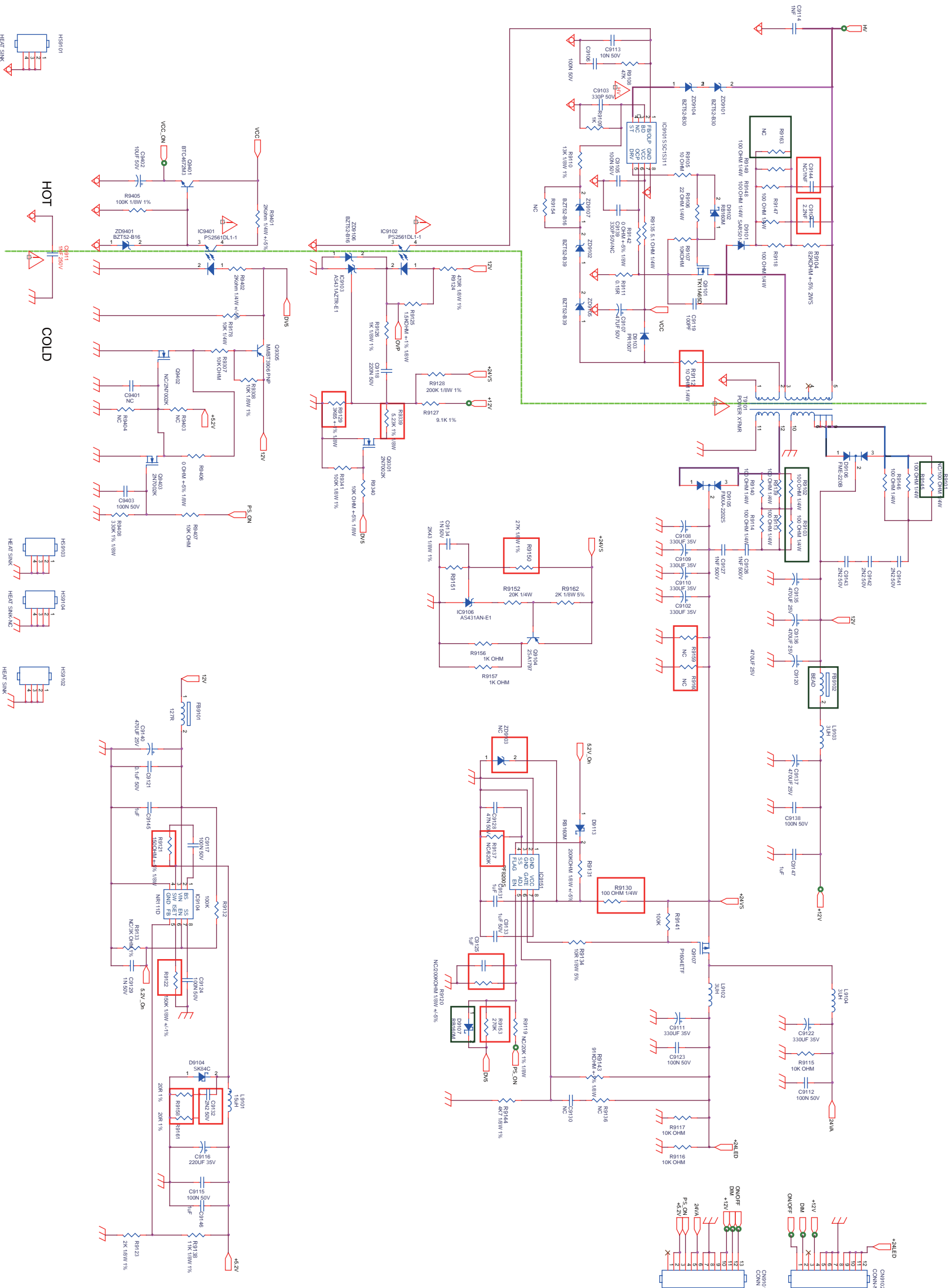

Main Power	715G5792
1	20130202
2	
3	
4	



# A04 LED Driver D2D

# A04

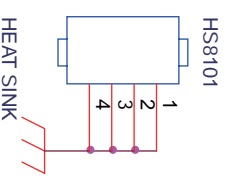
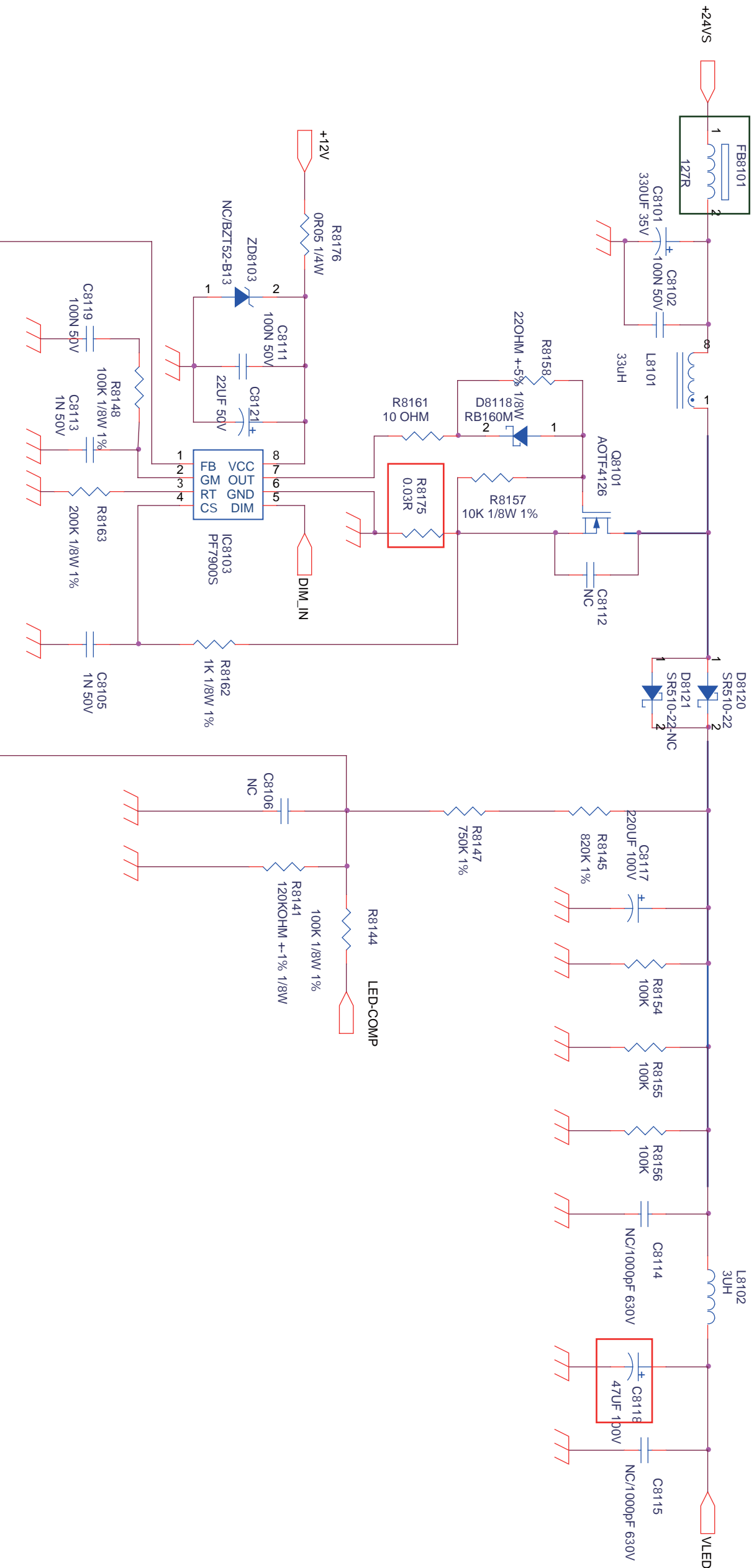

LED Driver D2D	715G5792	4	2013-04-26
			back to div/table
			2013-Apr-26
			19430_507_130114.eps
			130114

**A05** LED Current Balance

**A05**

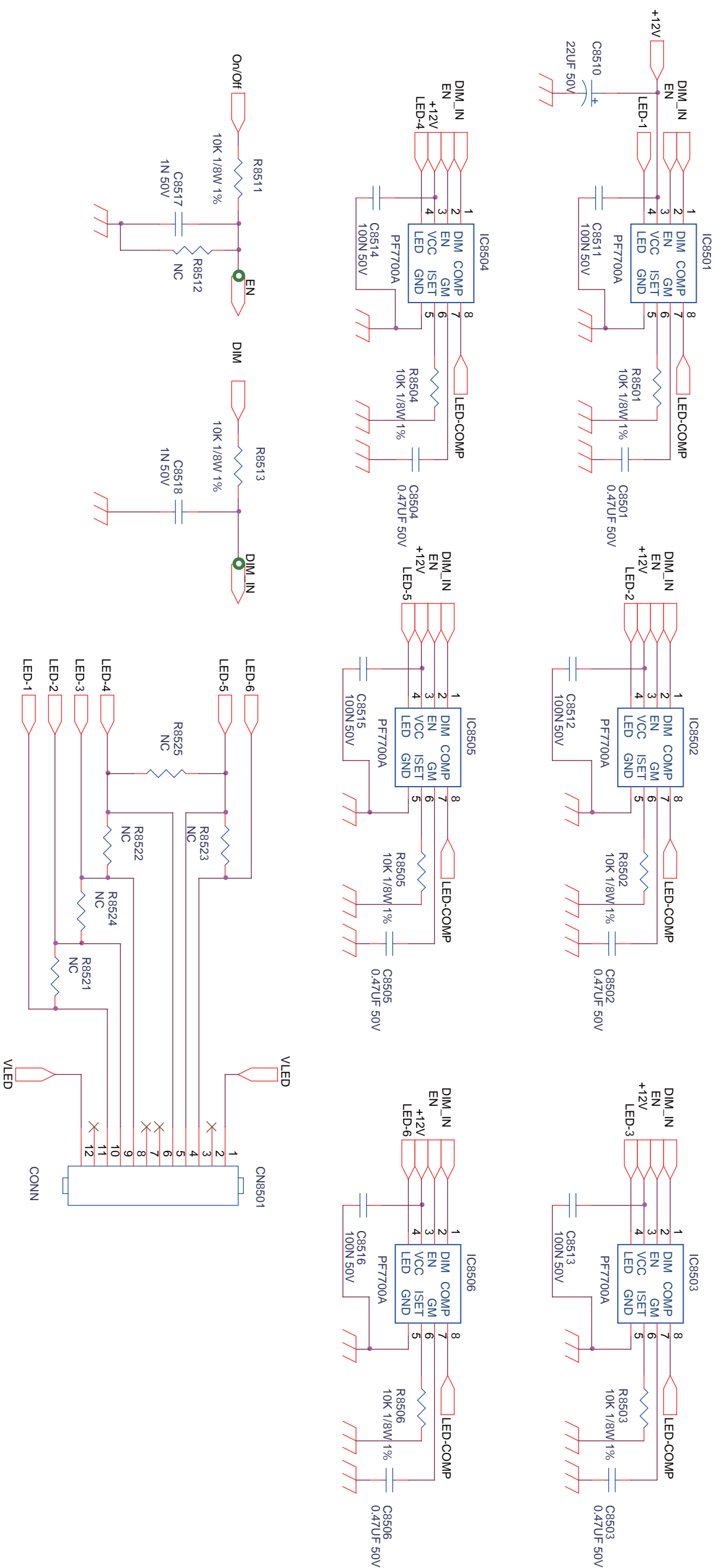

LED Current Balance	715G5792
1	2013-04-26
2	19430_508_130114.eps
3	130114

10-2-6 Power layout top

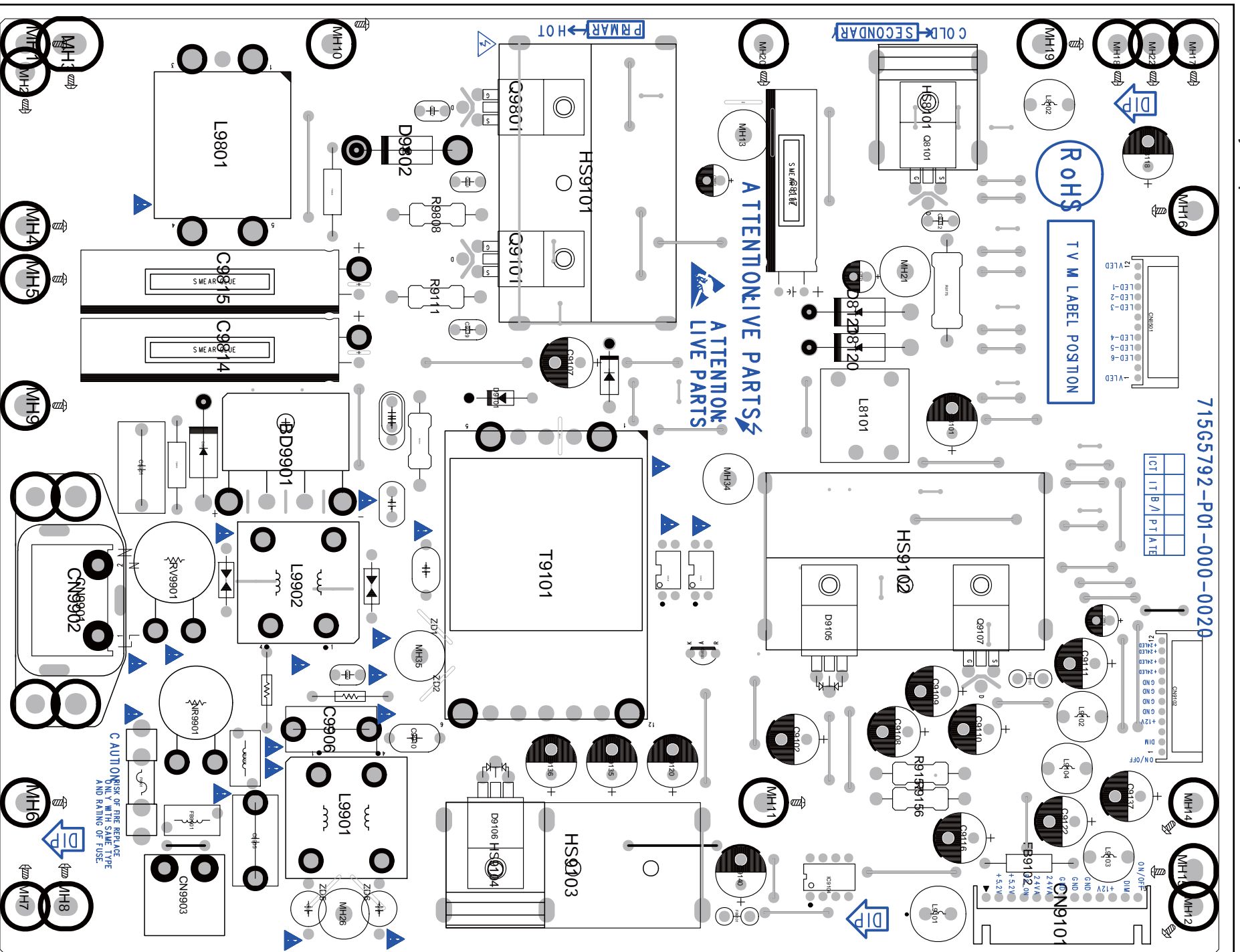

Power layout top	715G5792	4	REVISION

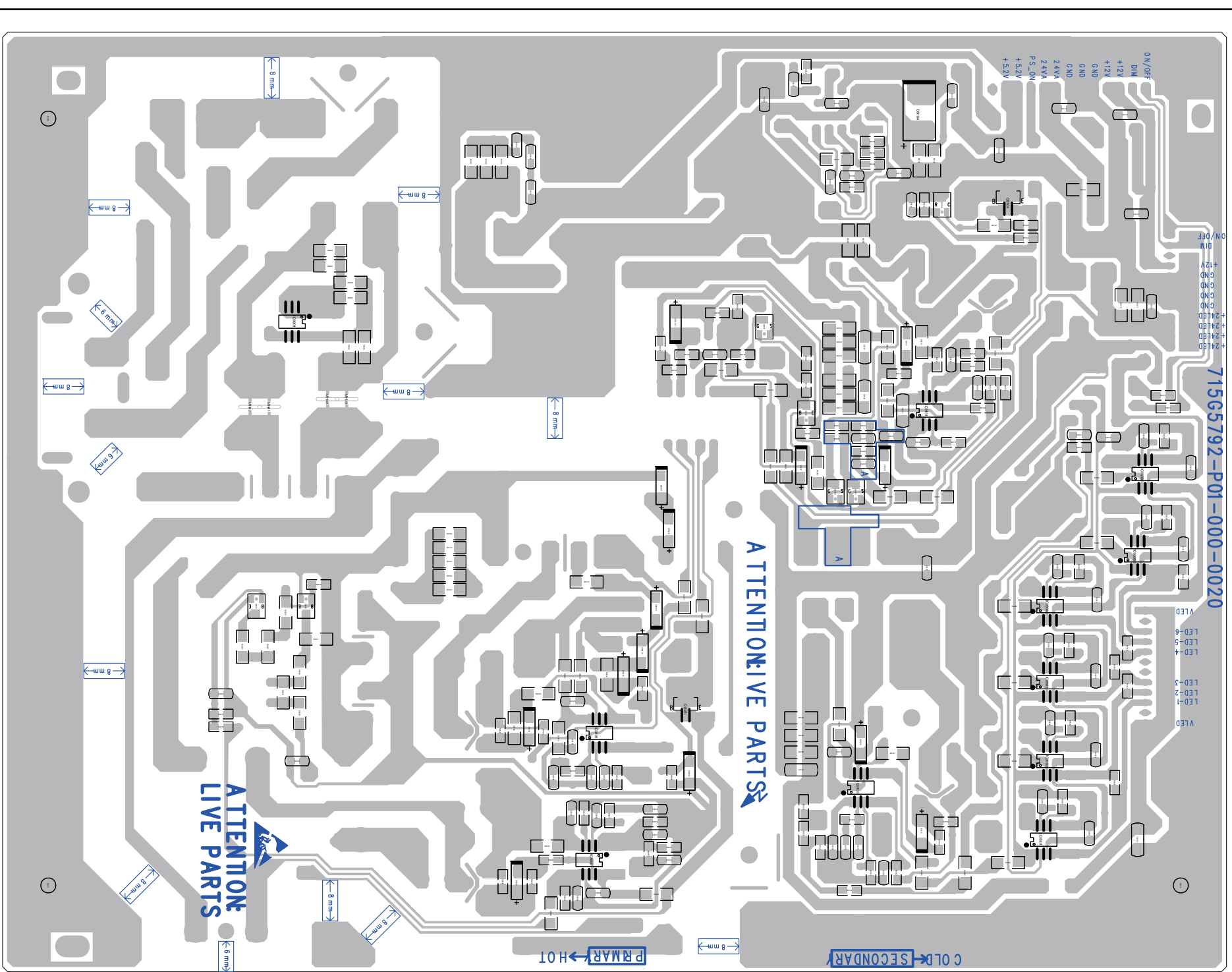

Power layout bottom	715G5792	4	REVISED

**A01**

AC Input

**A01**

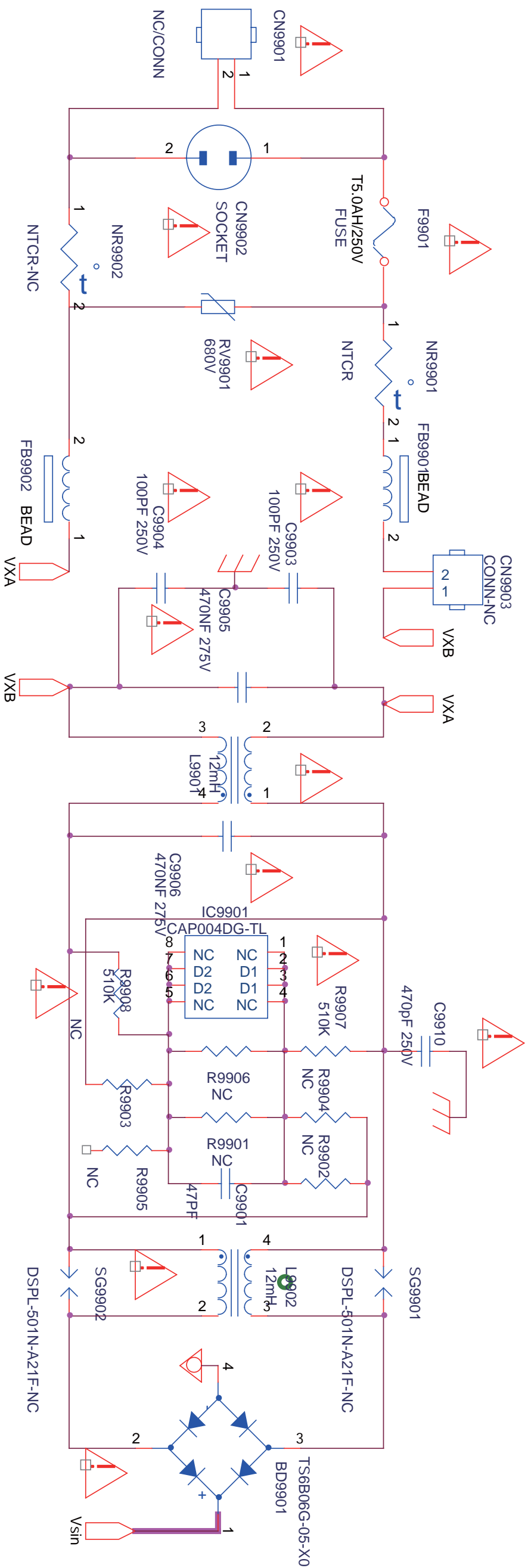

AC Input	715G6050
19500_504_130408.eps	130408

# A02

## Main Power

# A02

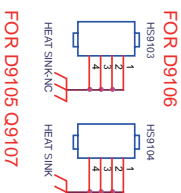
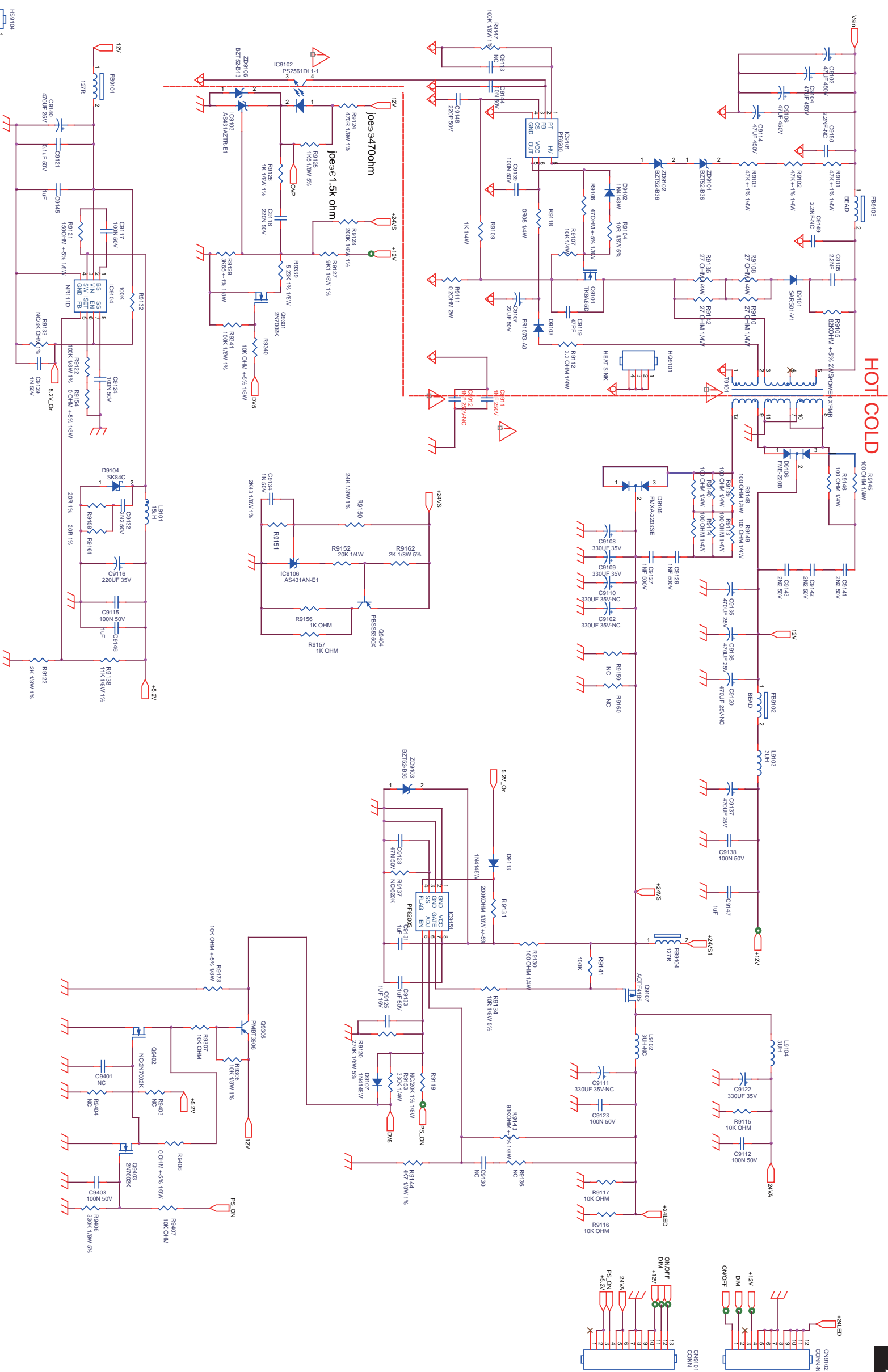

Main Power		715G6050	
1	2013-04-26	1	130408
2		2	
3		3	
4		4	



**A03** LED Driver D2D

**A03**

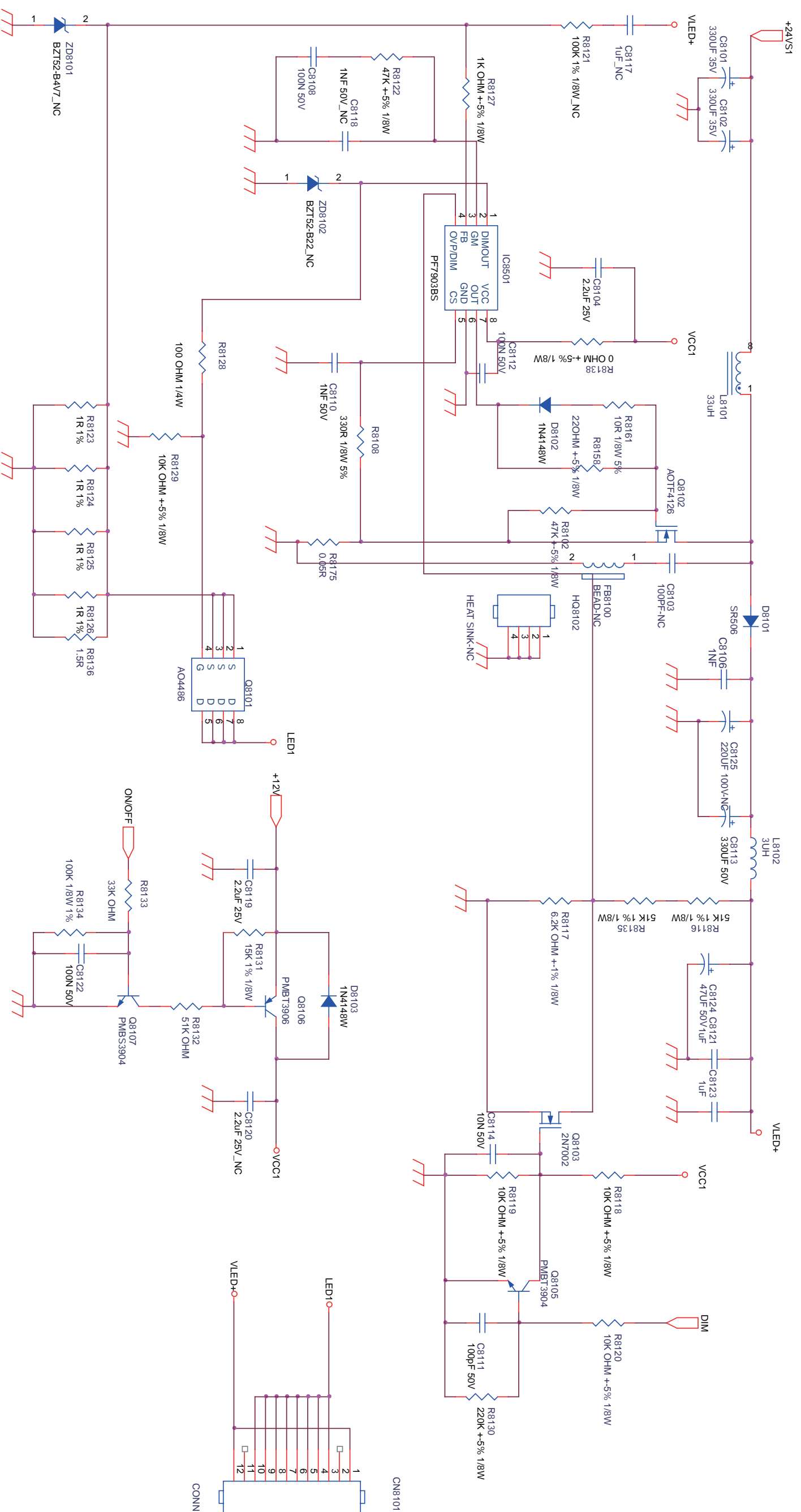

LED Driver D2D	715G6050
1	2
2	3
3	4
4	5
5	6
6	7
7	8
8	9
9	10
10	11
11	12

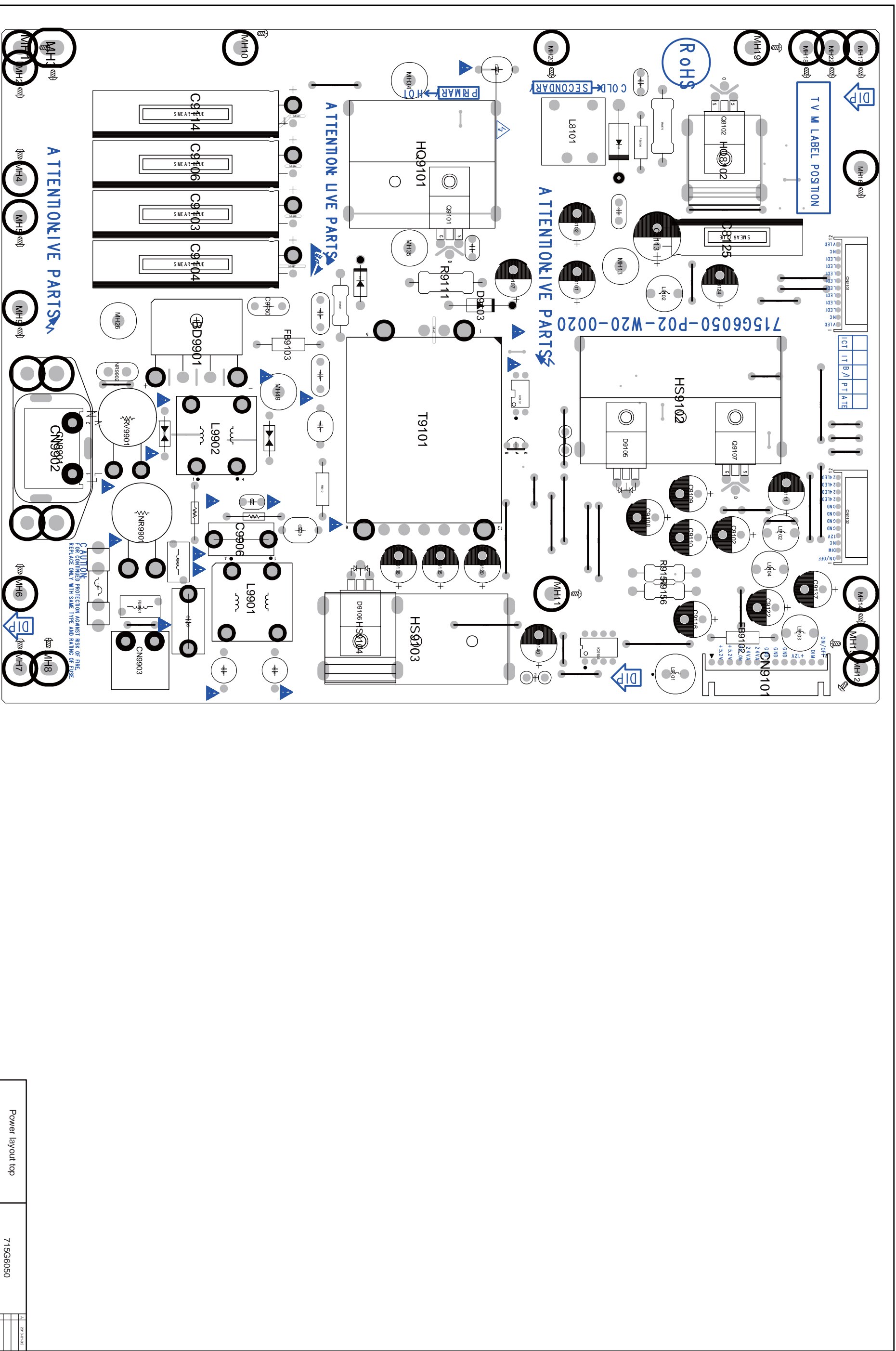

Power layout top

715G6050

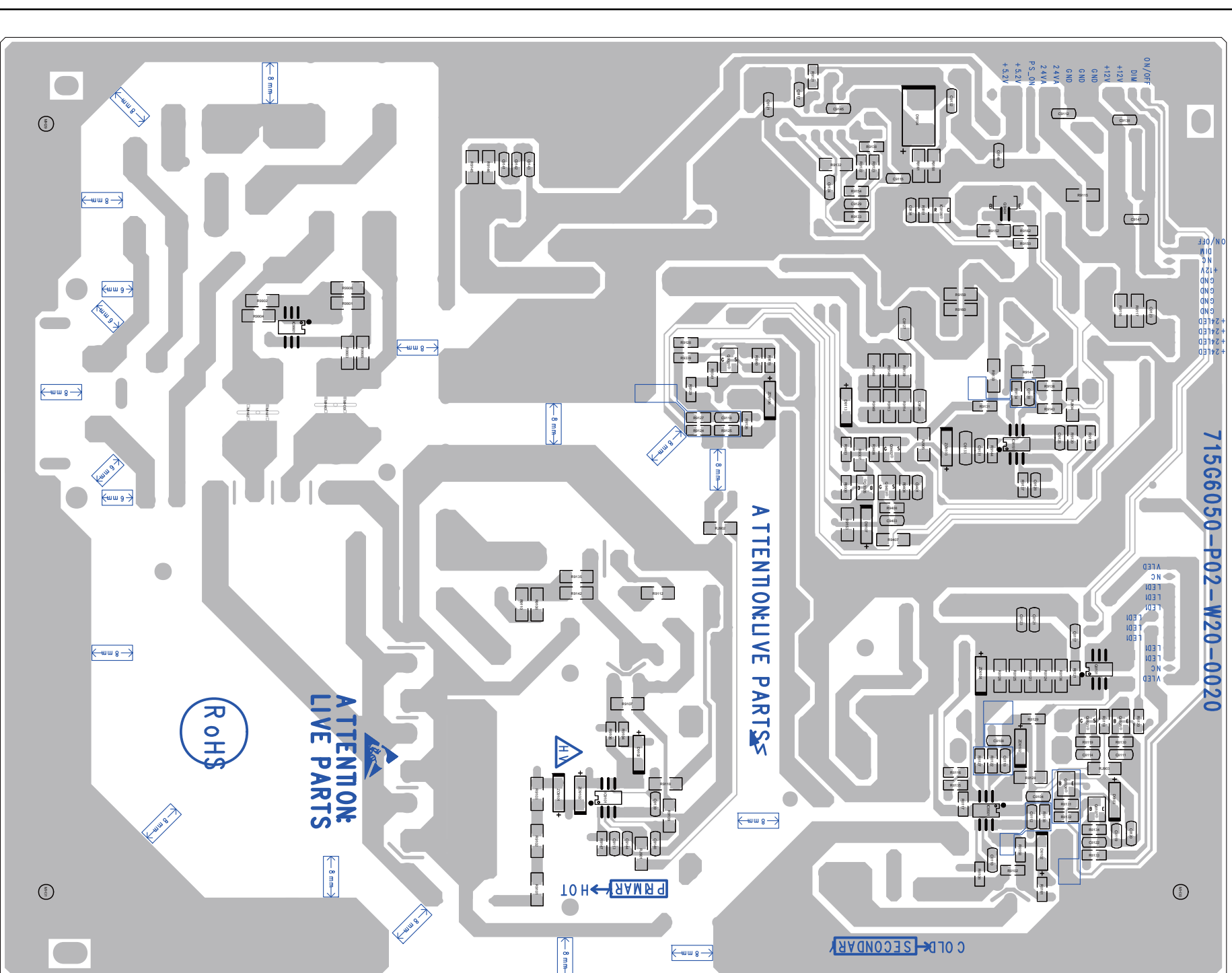

Power layout bottom	715G6050	4	REVISED

**B01**

Power

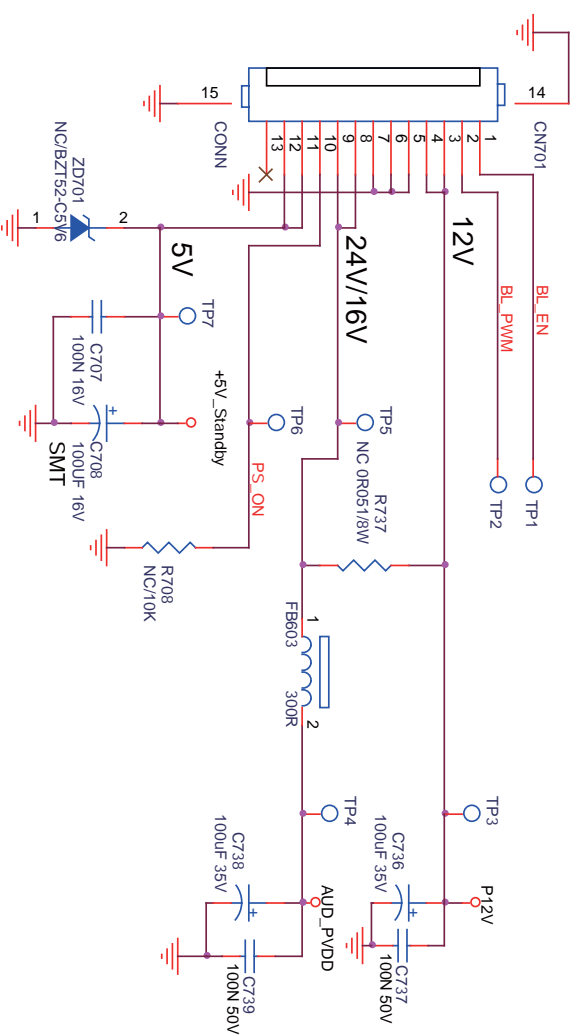

System power control

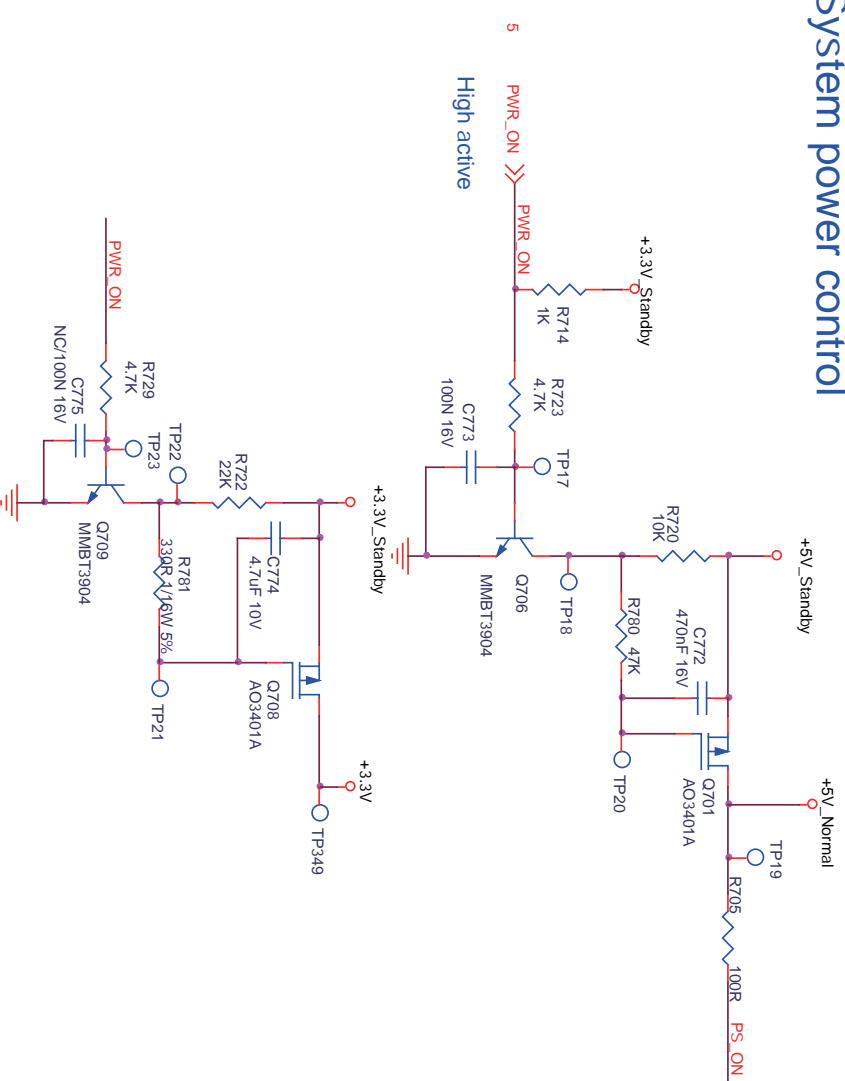

**B01**

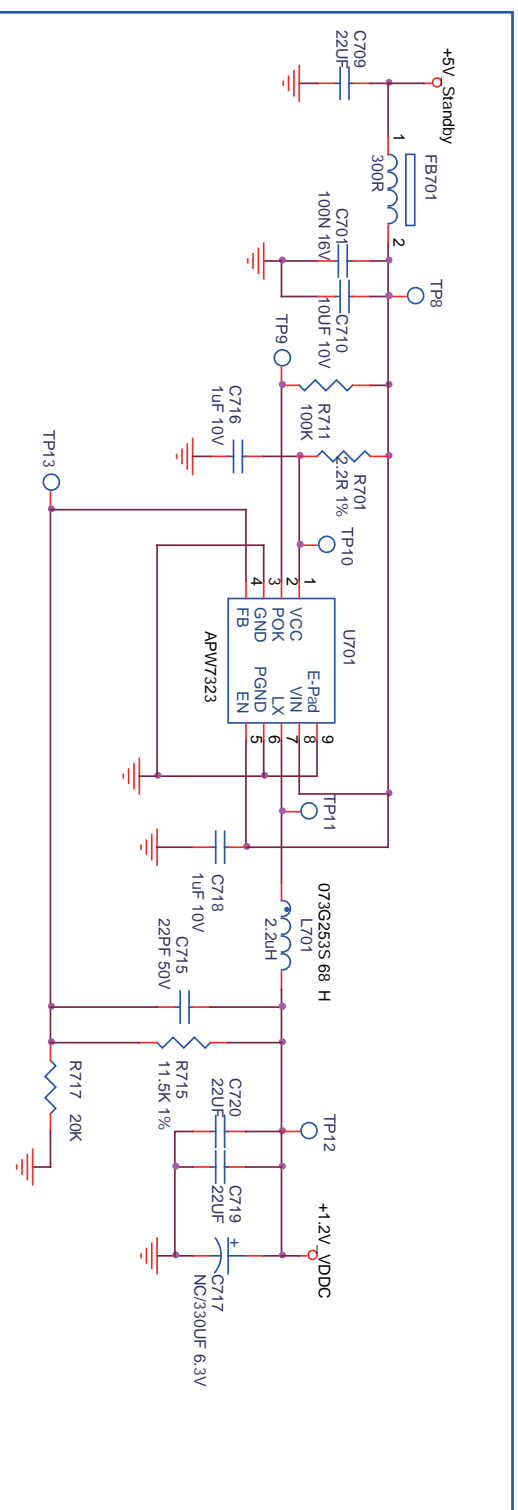

Standby Power

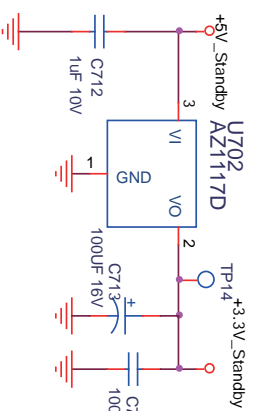

DDR Power

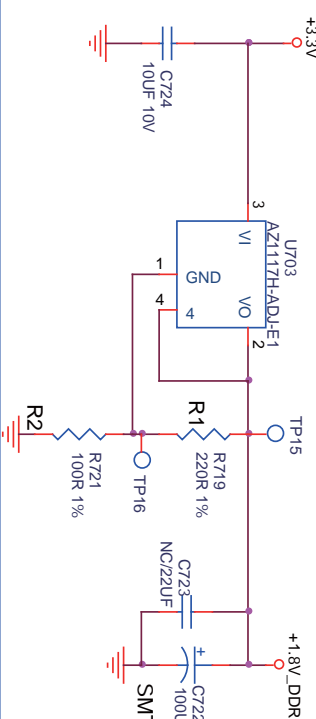

Backlight Control

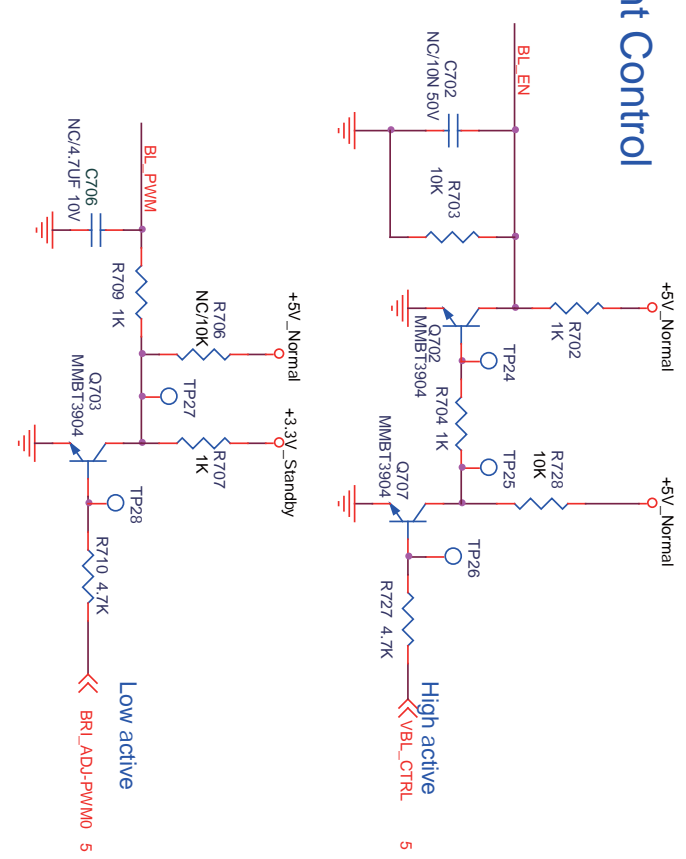

Power

715G5749



**B03** LVDS

**B03**

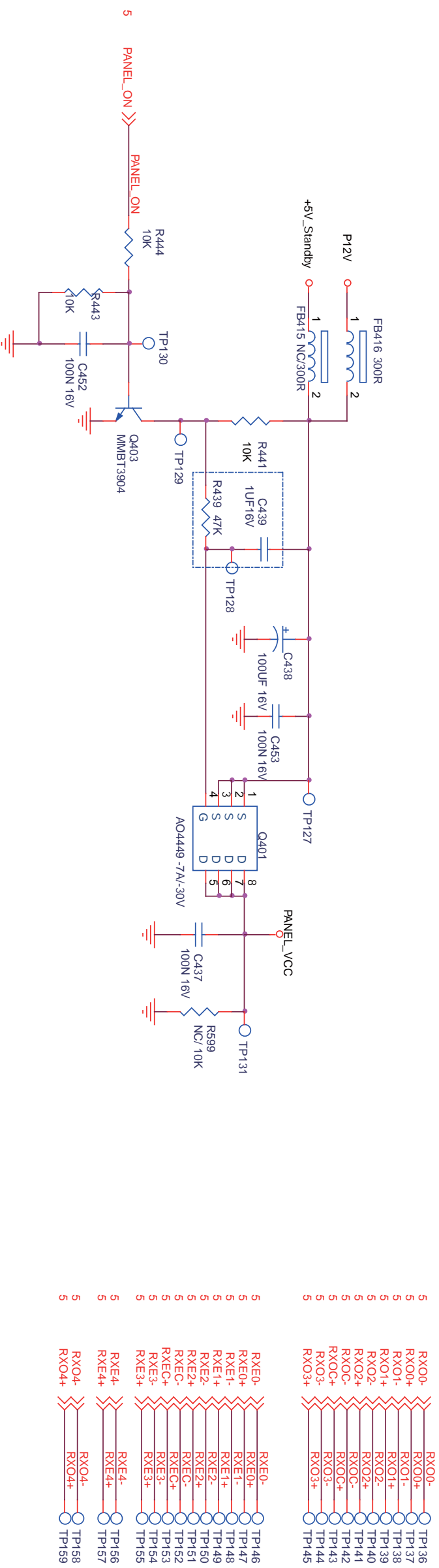

**Master Panel Connector**

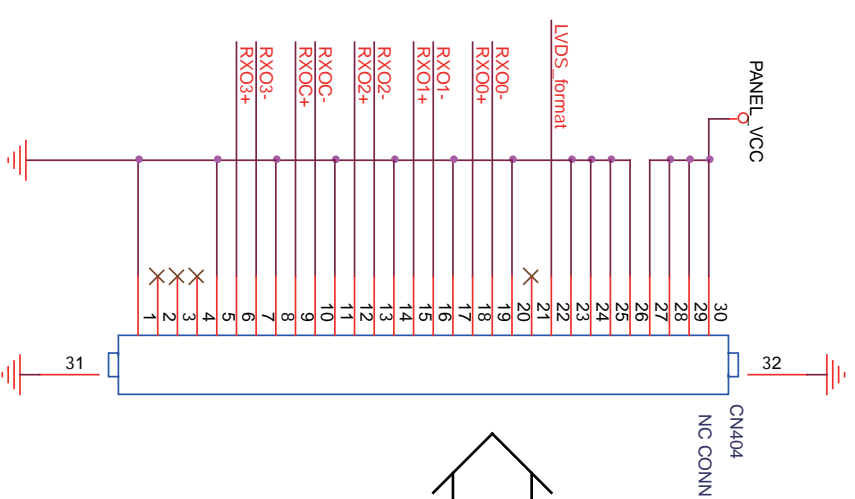
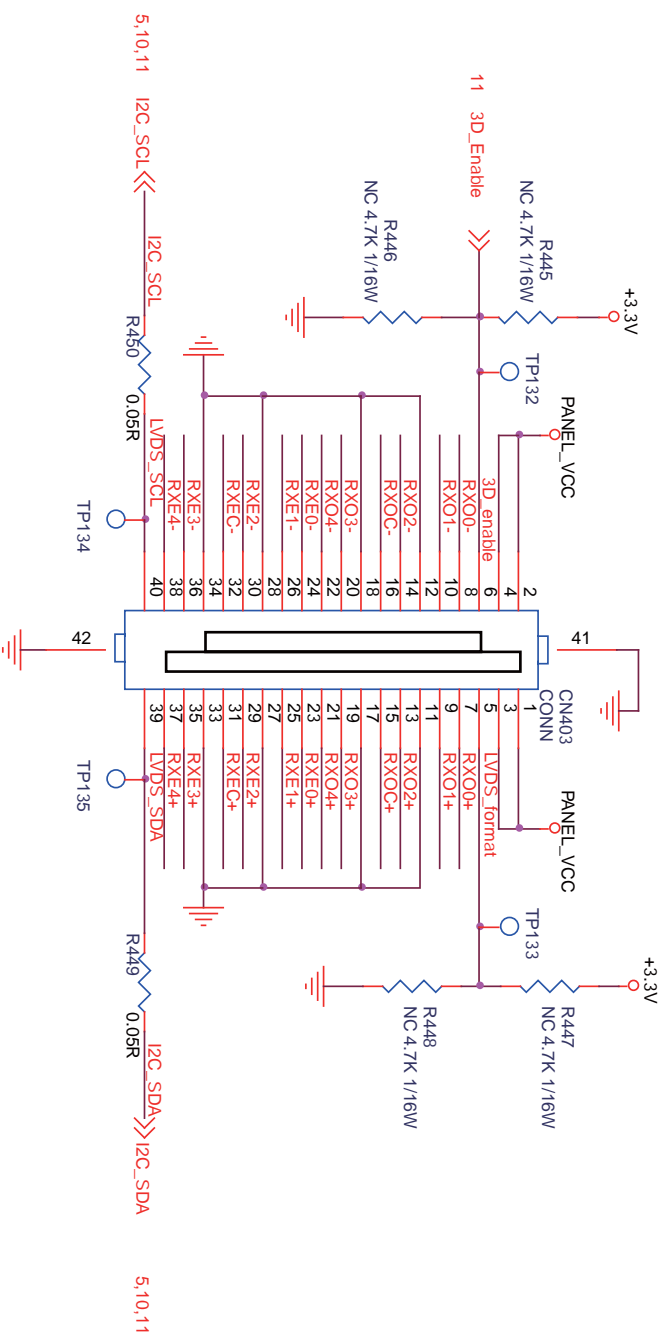

**For LCM290XX**

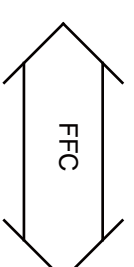

LVDS	715G5749	4	2017-12-28



**B04**

Video/Audio Interface/USB2.0

**B04**

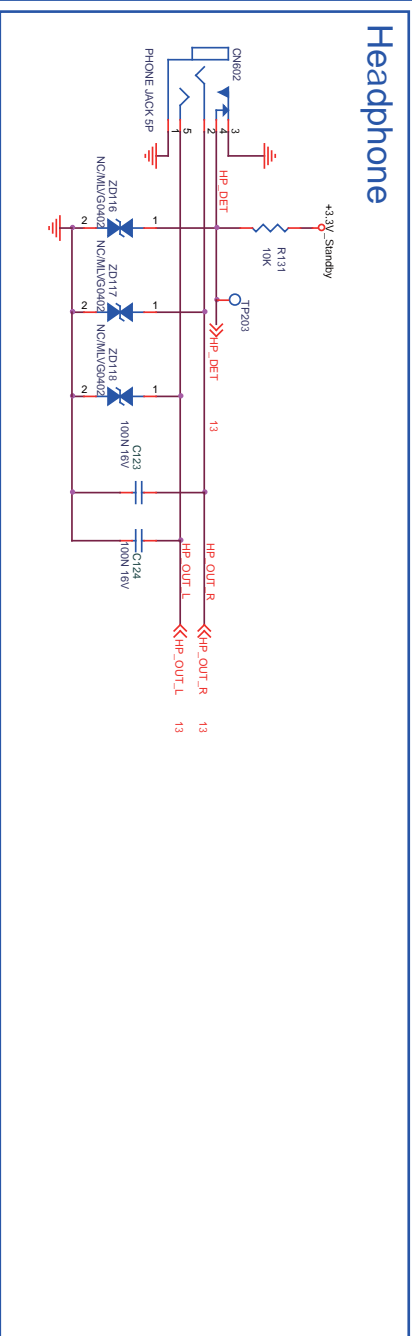
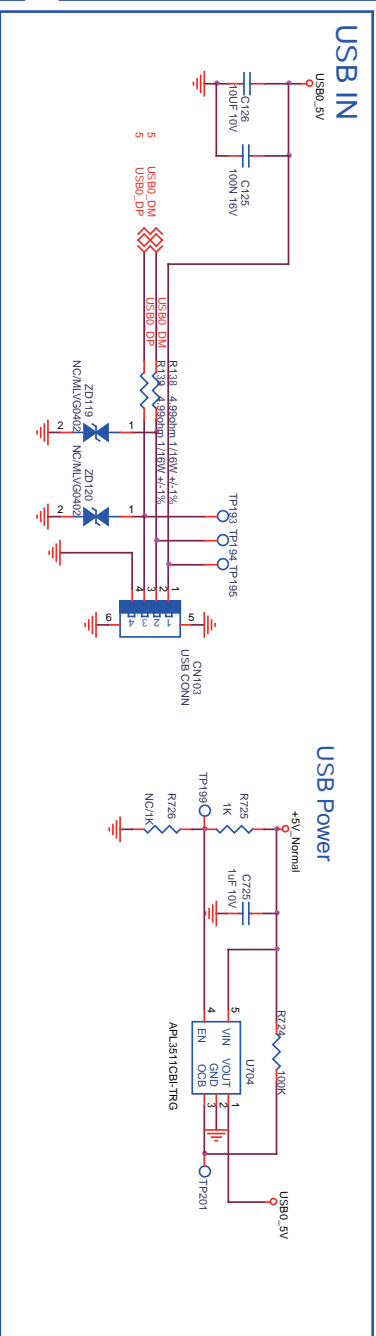
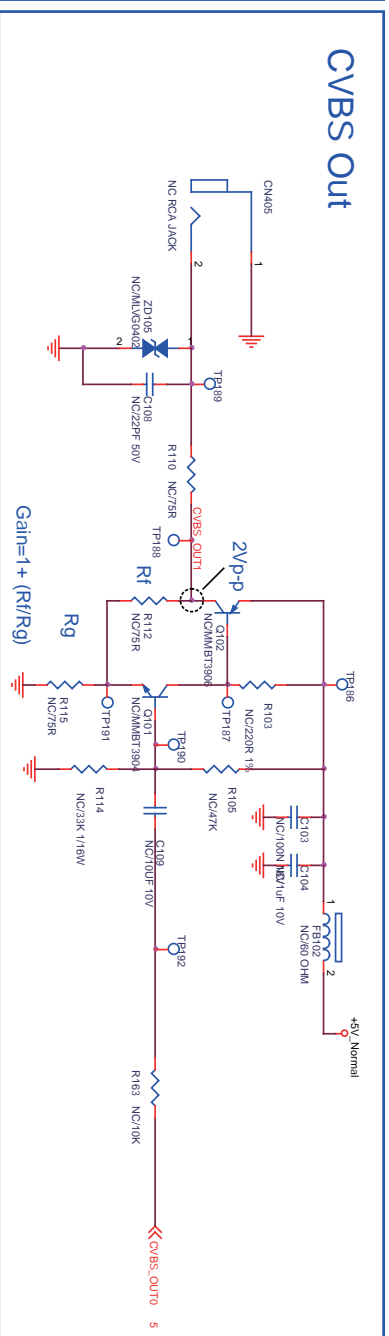
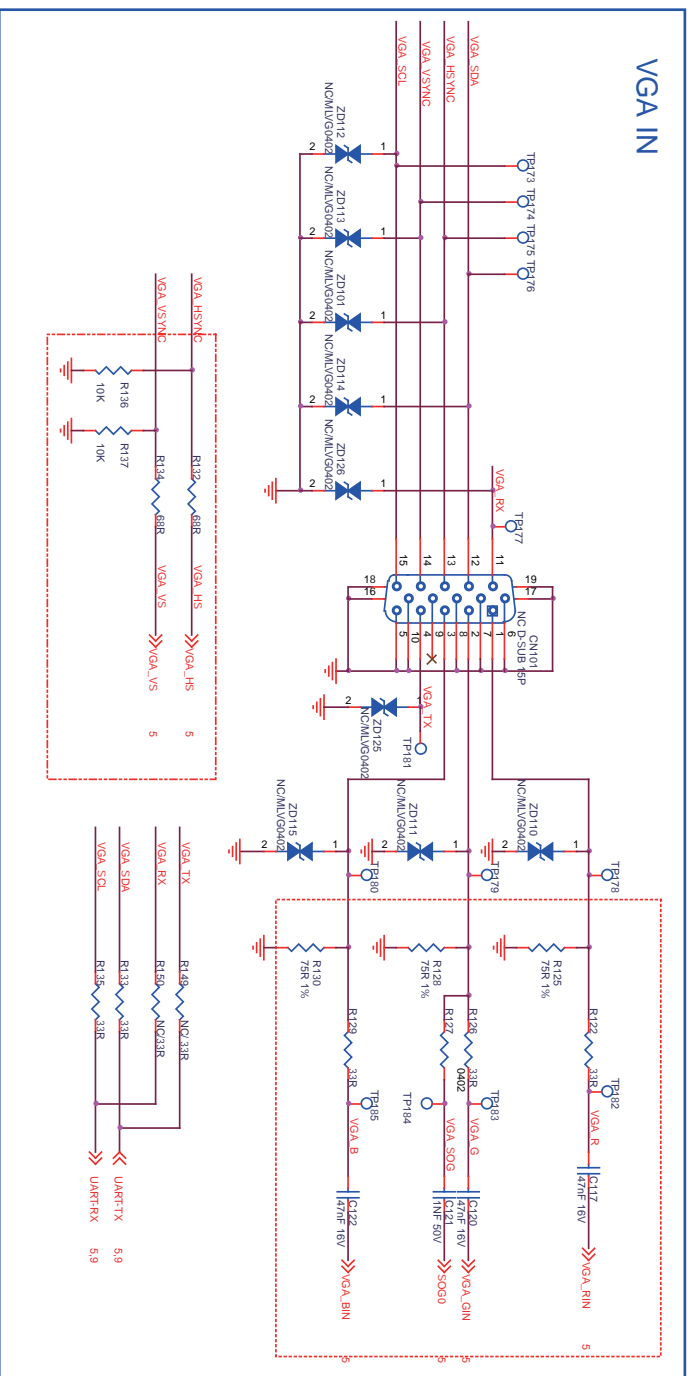
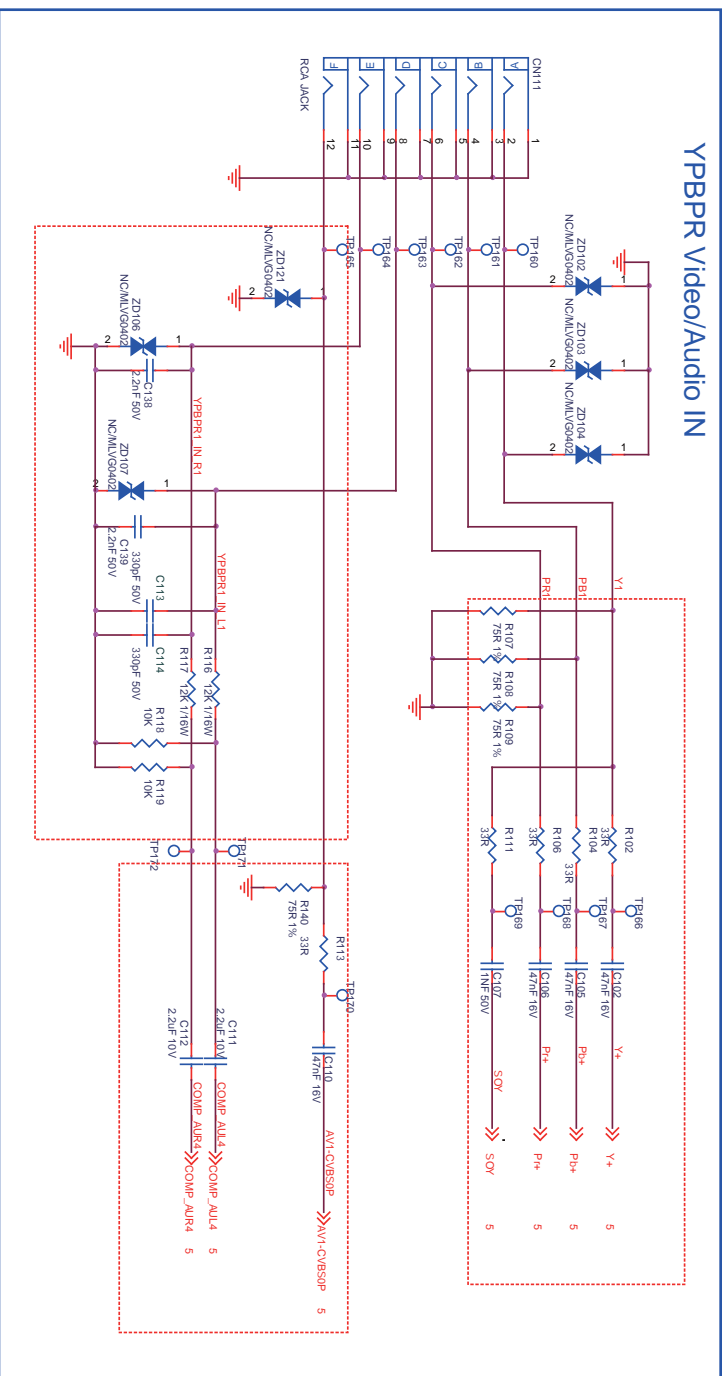

Video/Audio Interface/USB2.0	715G5749
19500_512_130409.eps	130409

**B05** HDMI

**B05**

HDMI\_A with ARC function

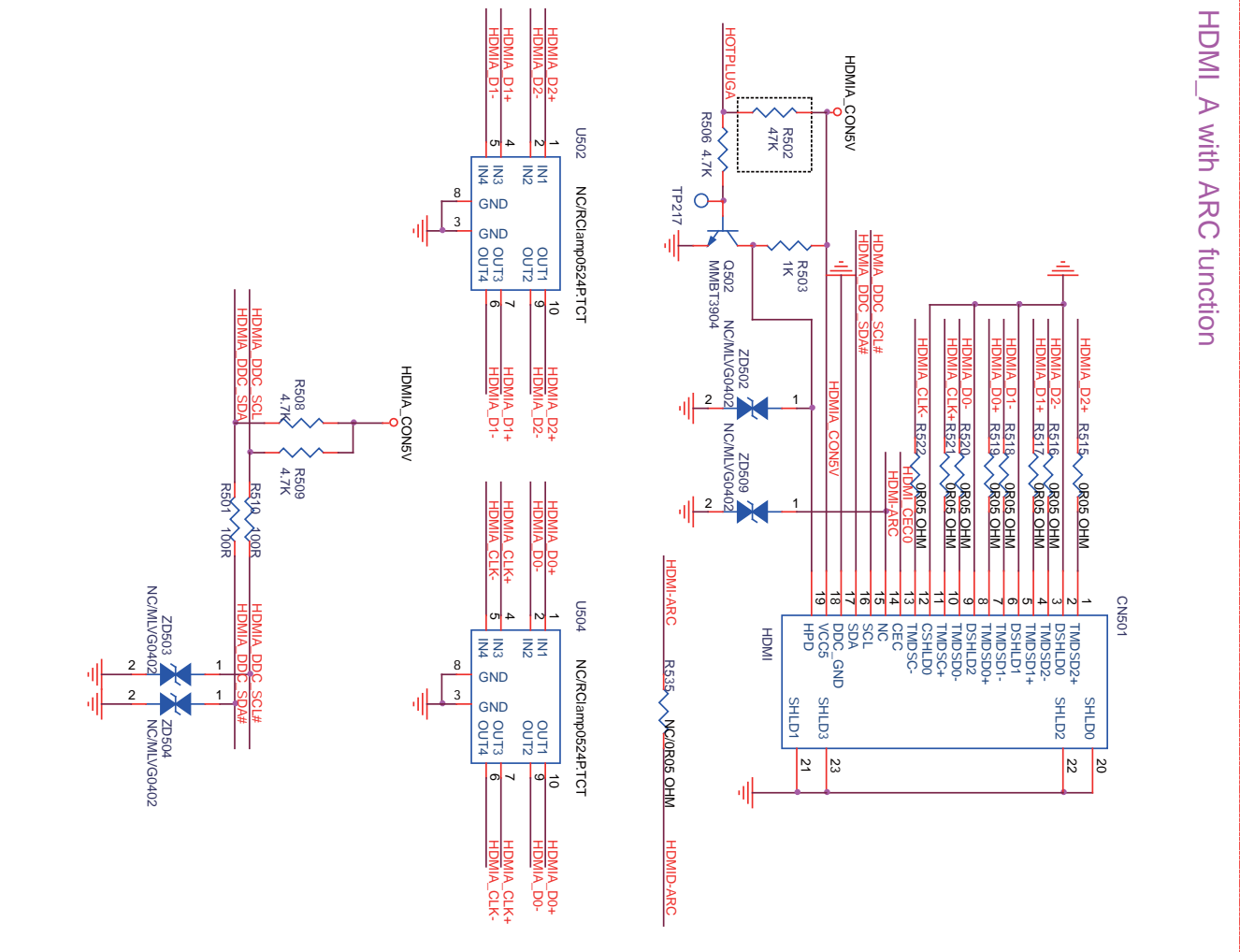

HDMI1\_D

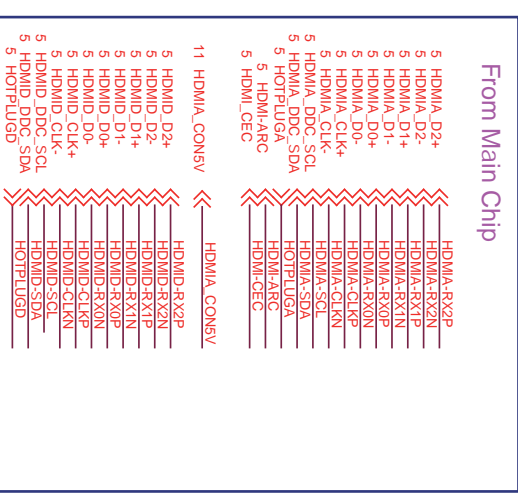
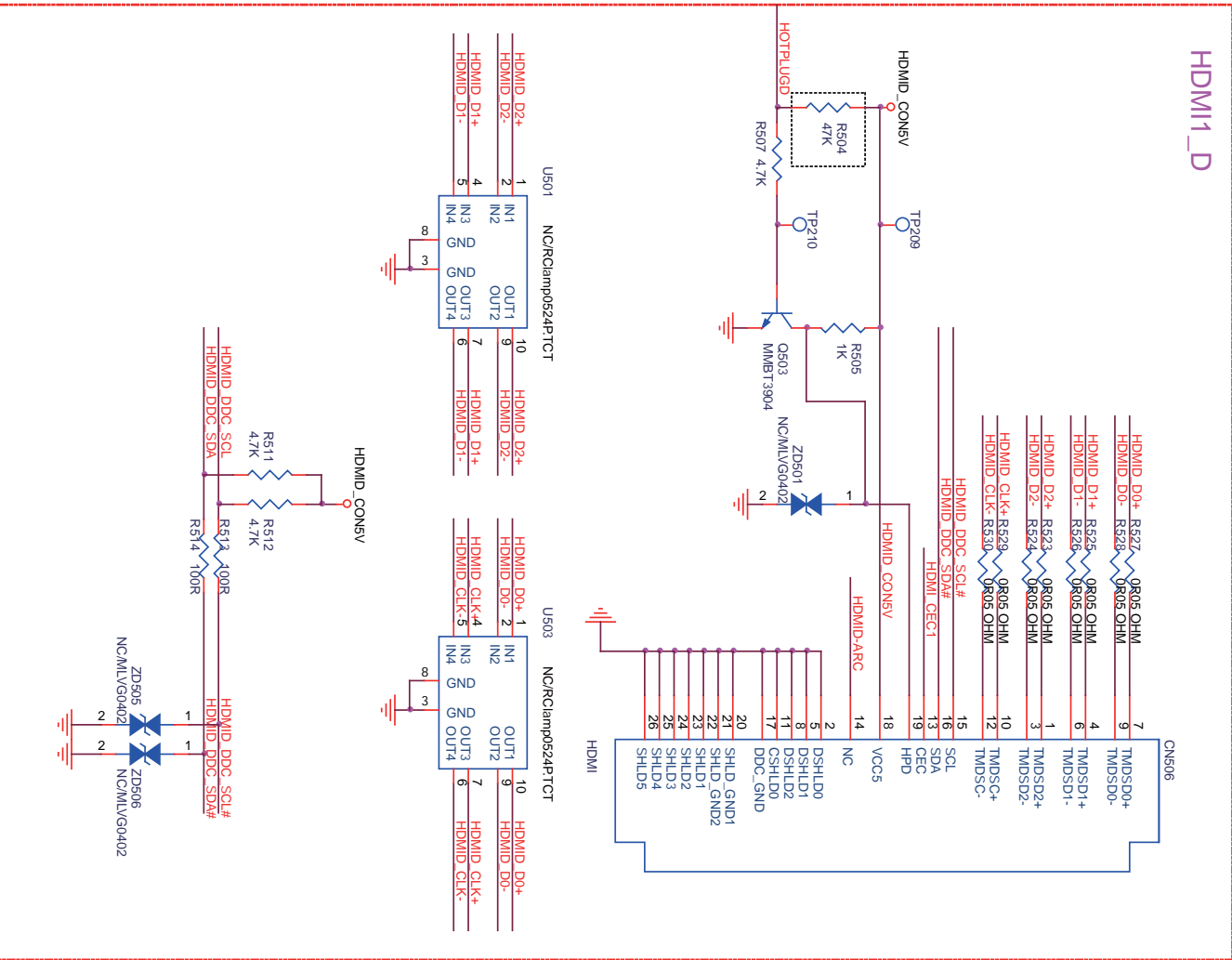

CEC Standard /MST6931 build in

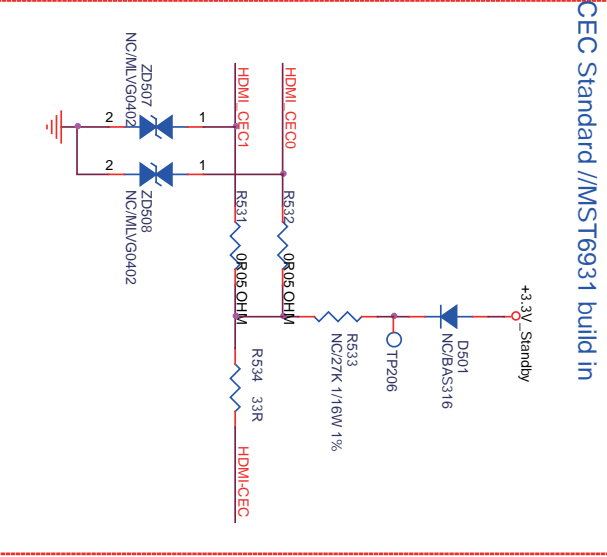

HDMI	715G5749	4	2013-04-26

**B06**

Keypad/IR

Keyboard and LED

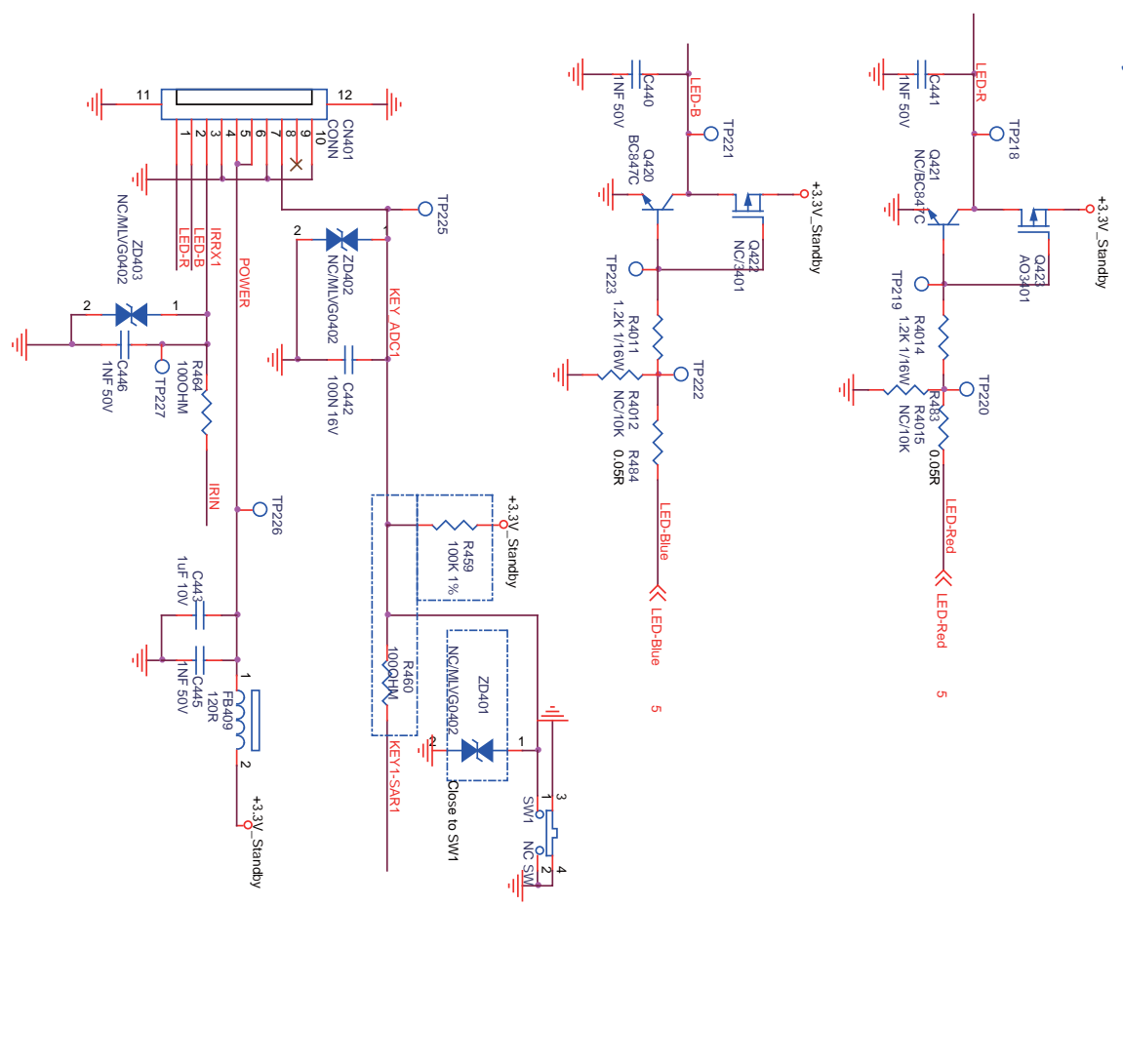

UART for HOTEL Mode

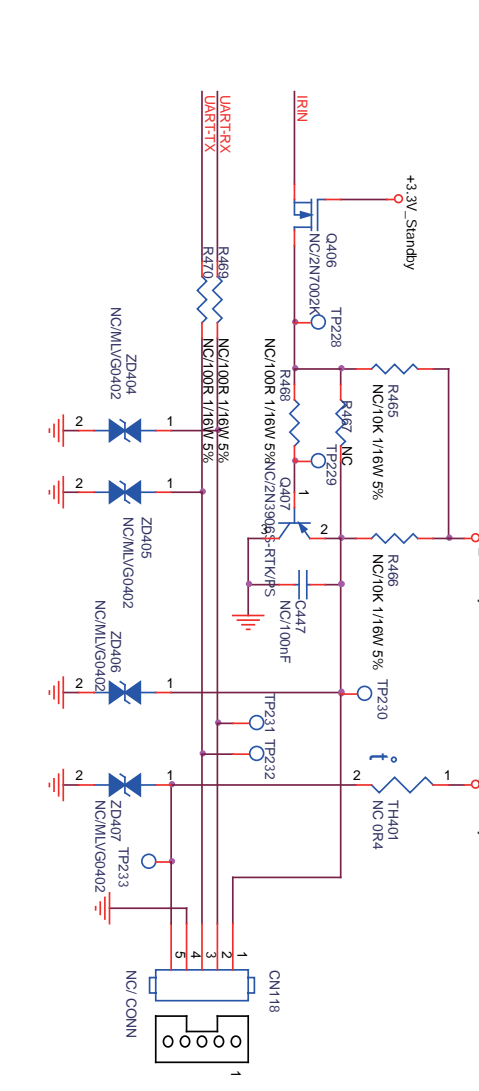

PC AUDIO IN

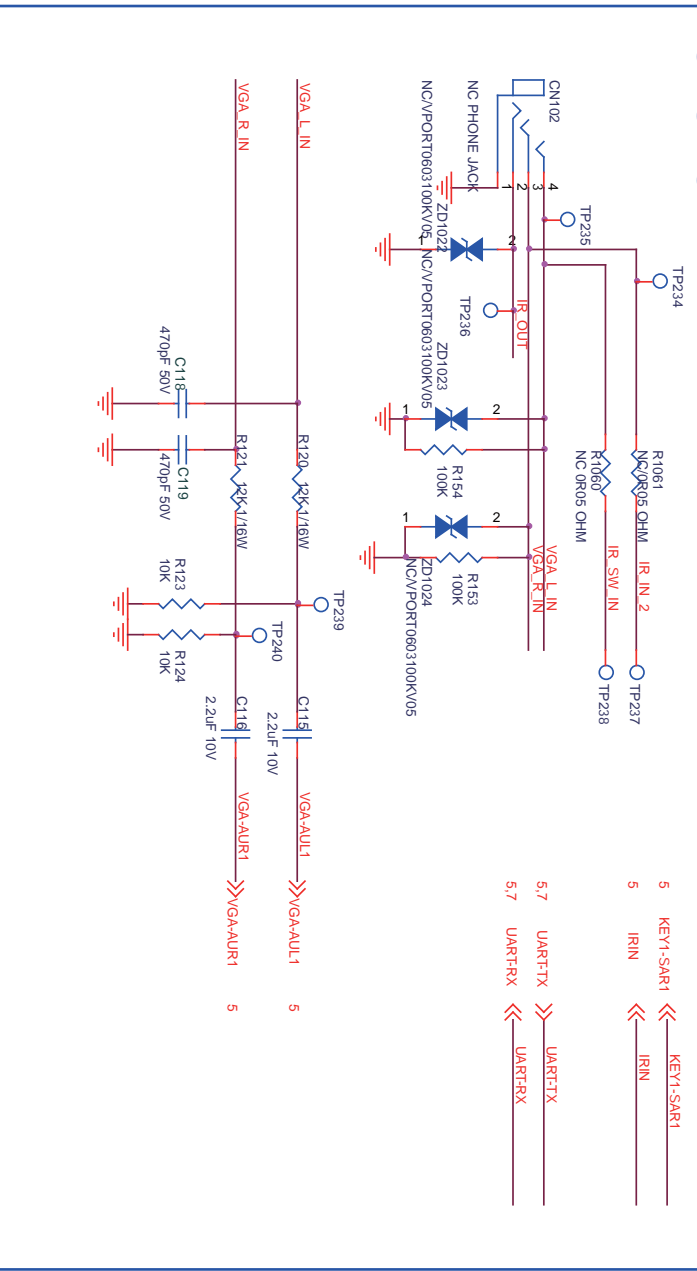

Shared with hotel mode

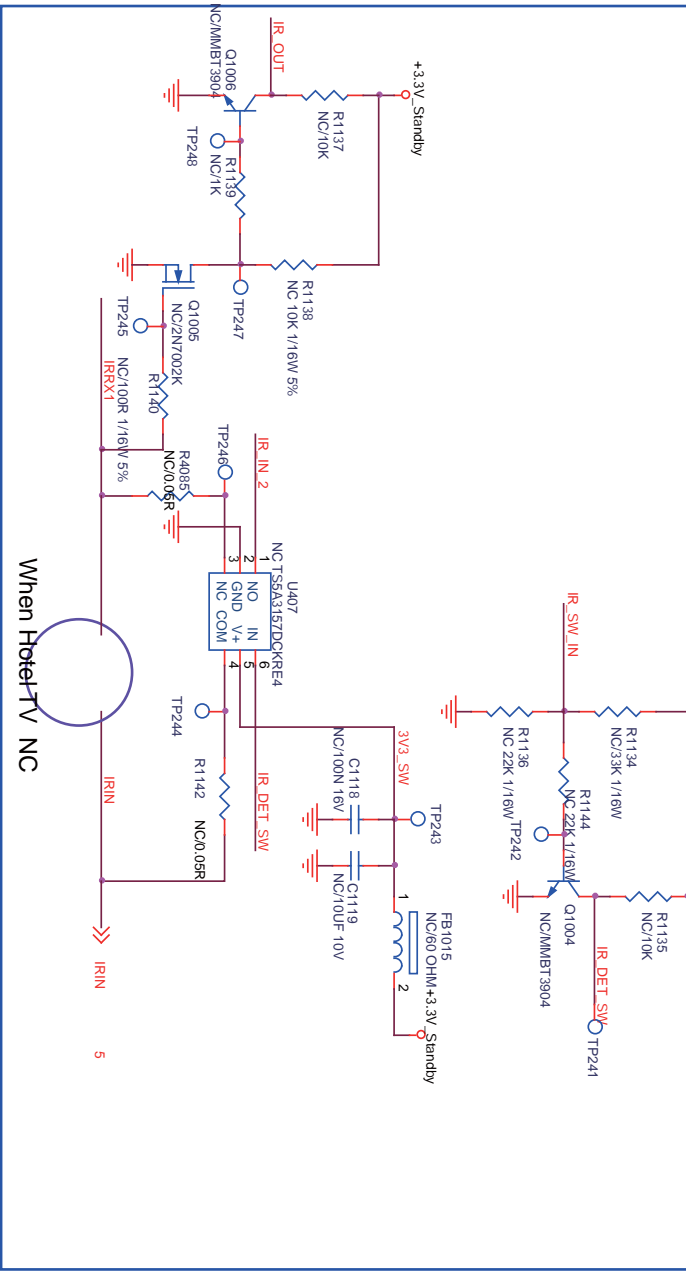

When Hotel TV NC



**B06**

Keypad/IR

715G5749

B07

Tuner

B07

### Tuner Power 3.3V\_TUNER

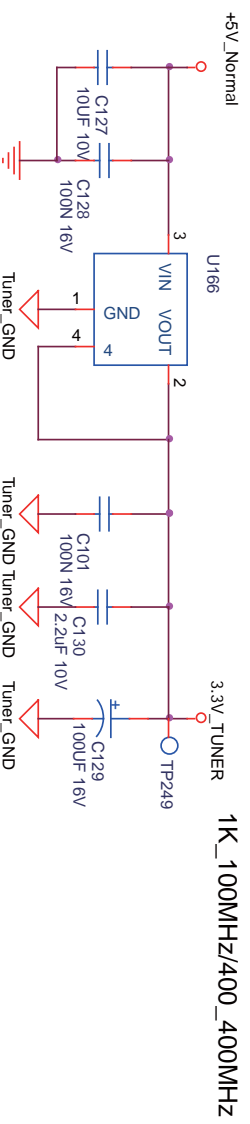

### Tuner LGTDST-H030F

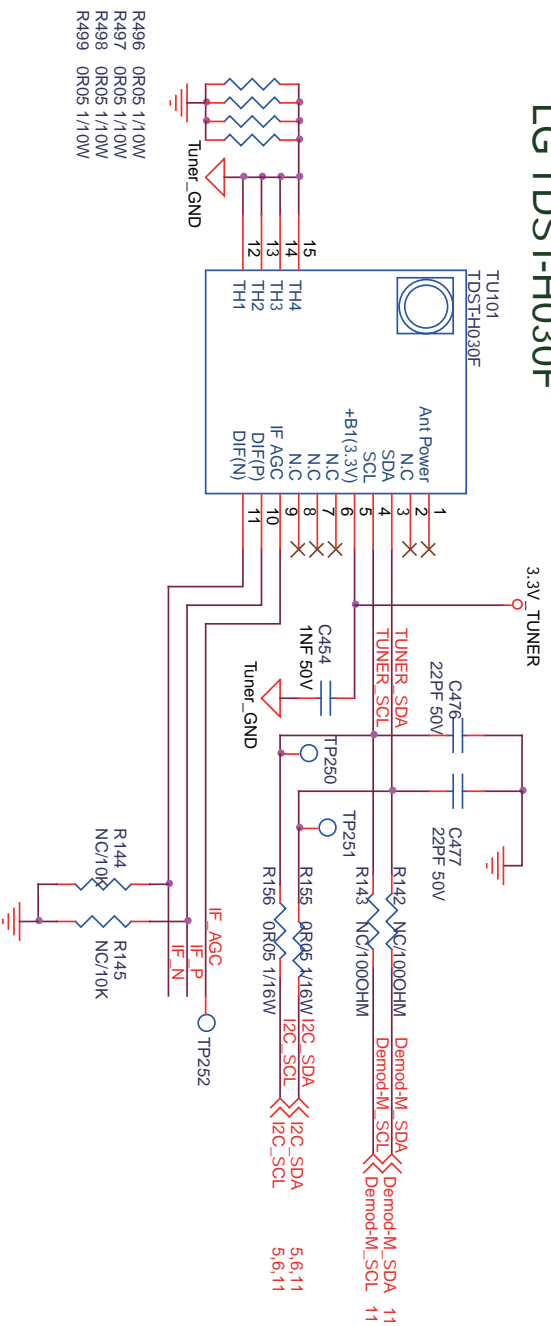

### IF\_AGC Control Circuit

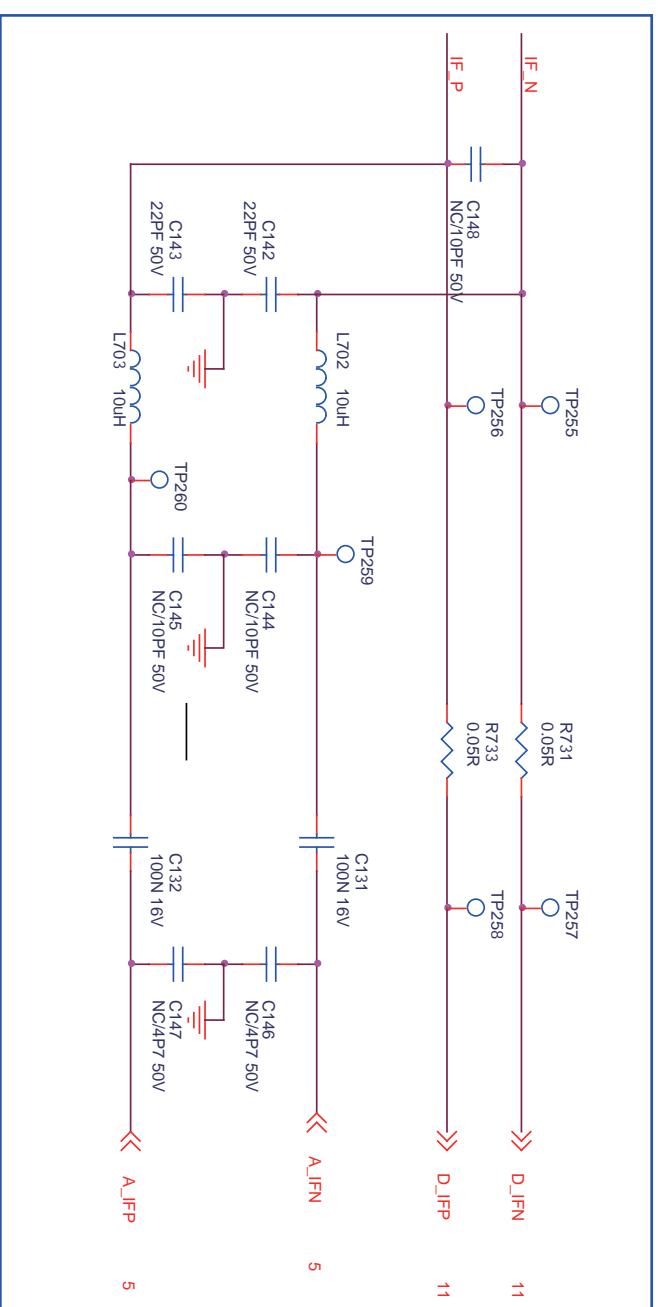
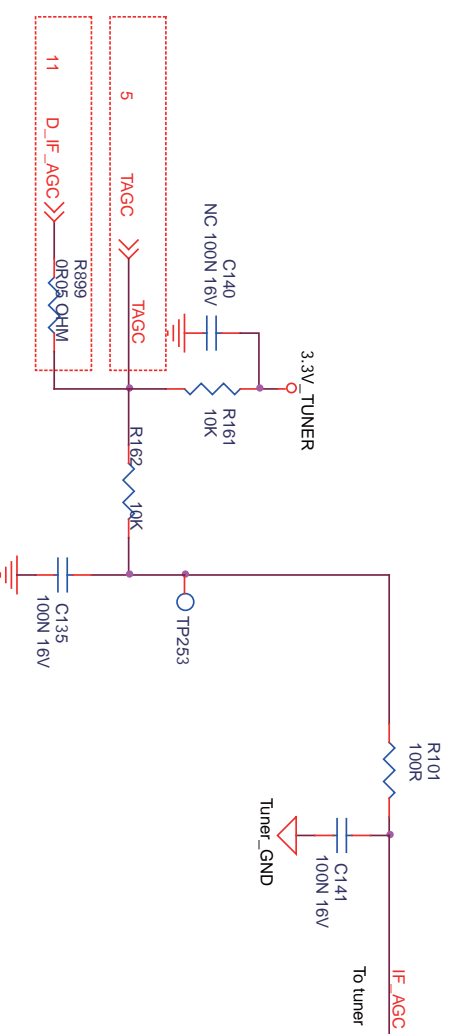

Tuner

715G5749

**B08**

MSB1400 Demod

**B08**

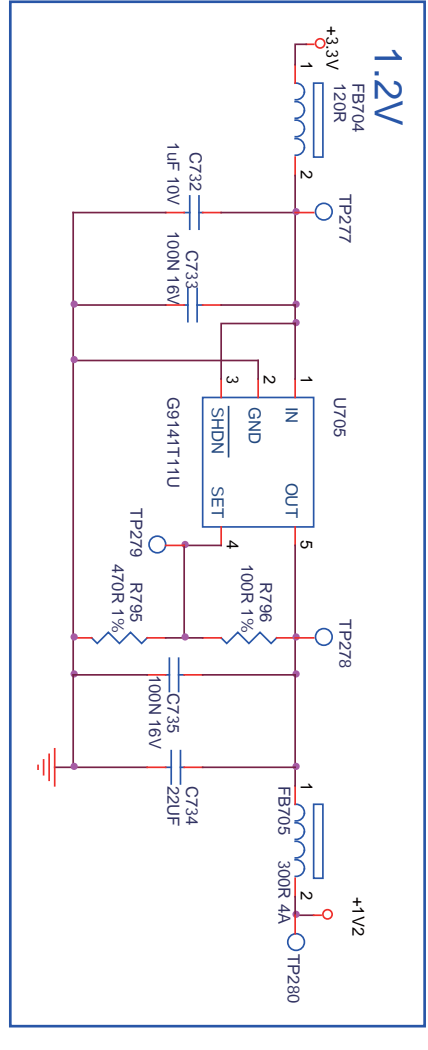
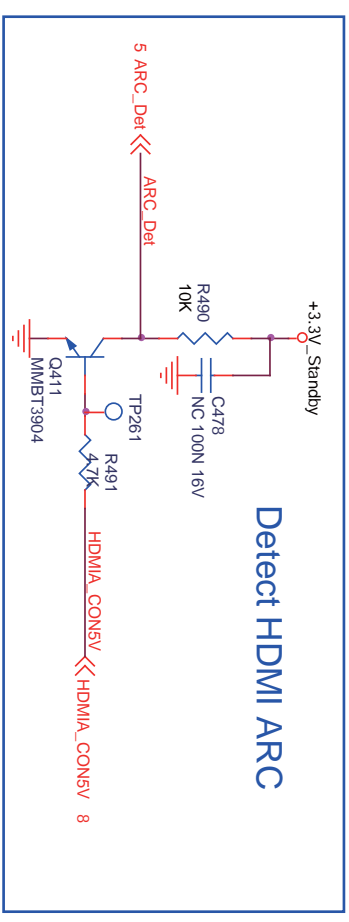
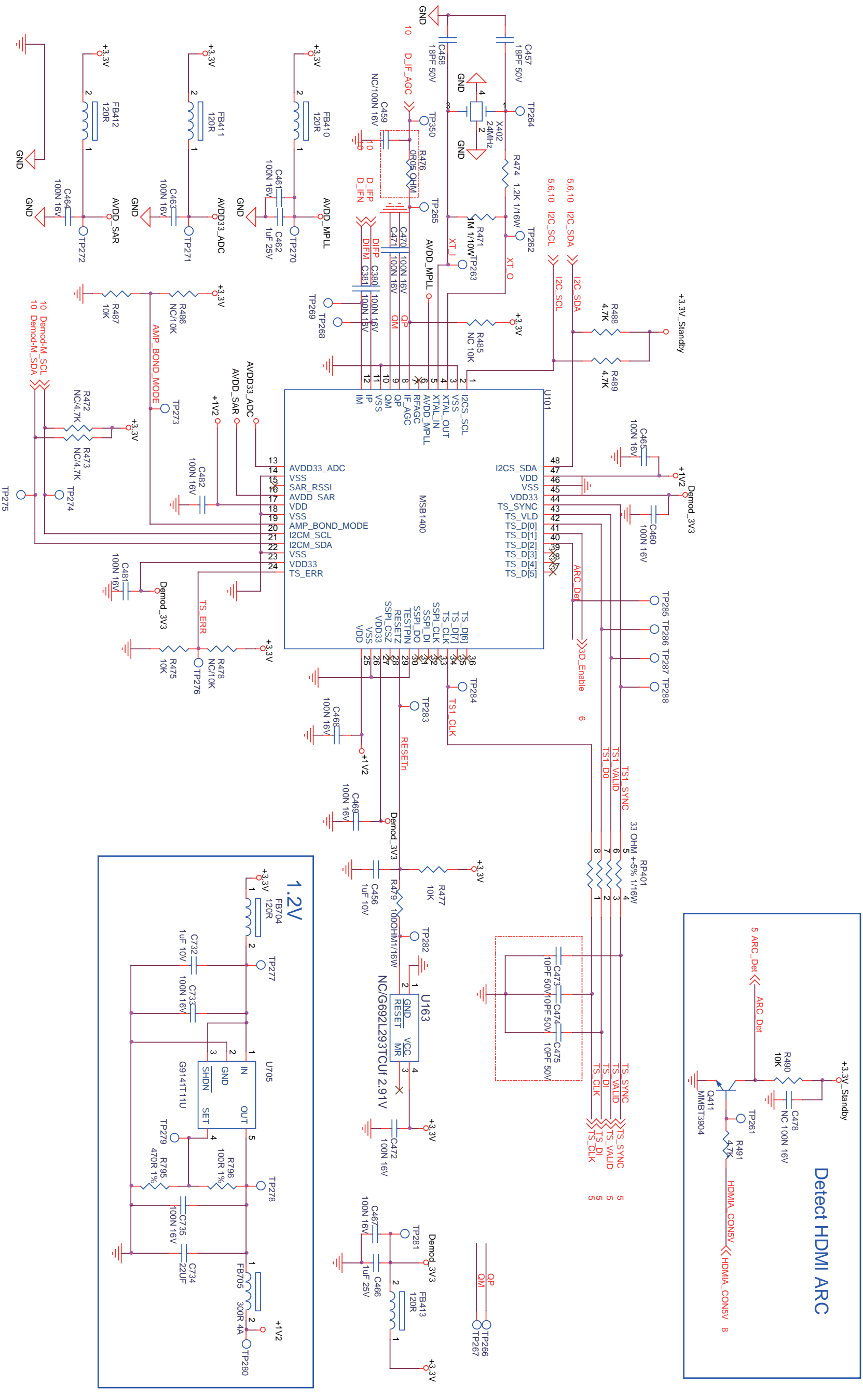

MSB1400 Demod	715G5749
19500_516_130409.eps	130409

**B09** AUDIO AMP

**B09**

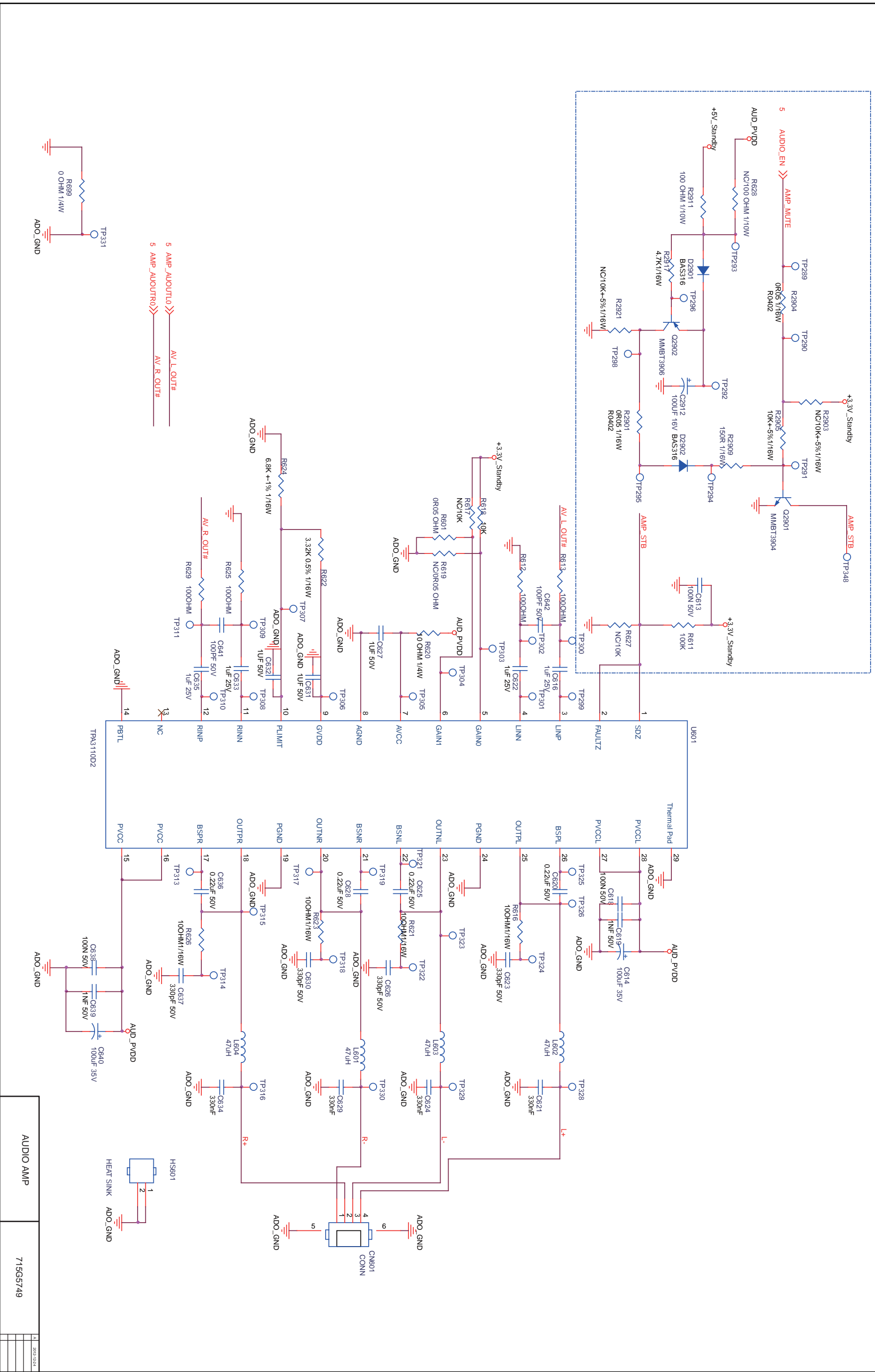

AUDIO AMP

715G5749



**B10**

Earphone pre amp

**B10**

# Headphone Amp

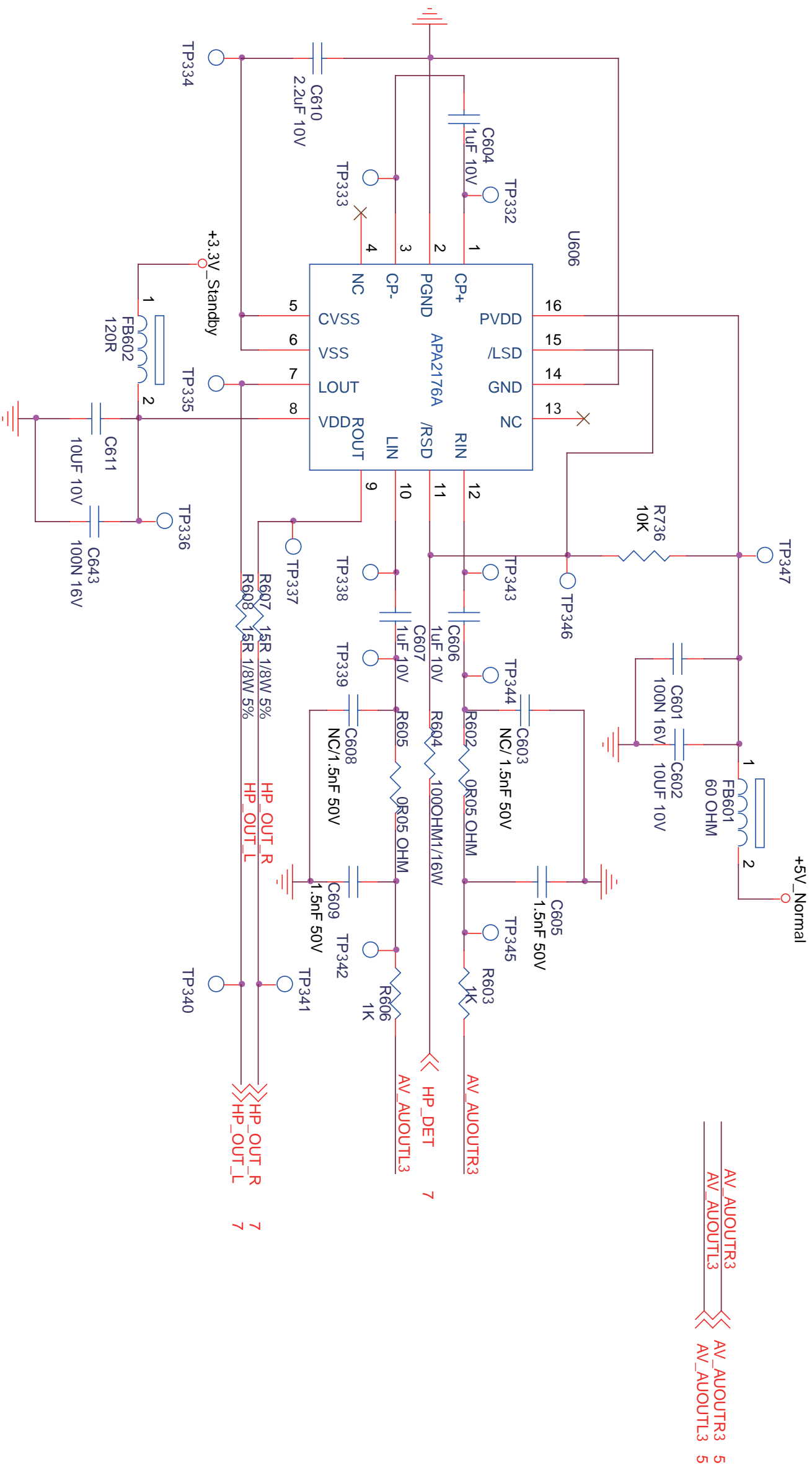

AV\_AUOUTR3 5  
AV\_AUOUTL3 5

HP\_OUT\_R 7  
HP\_OUT\_L 7

Earphone pre amp	715G5749	4	2013-04-26

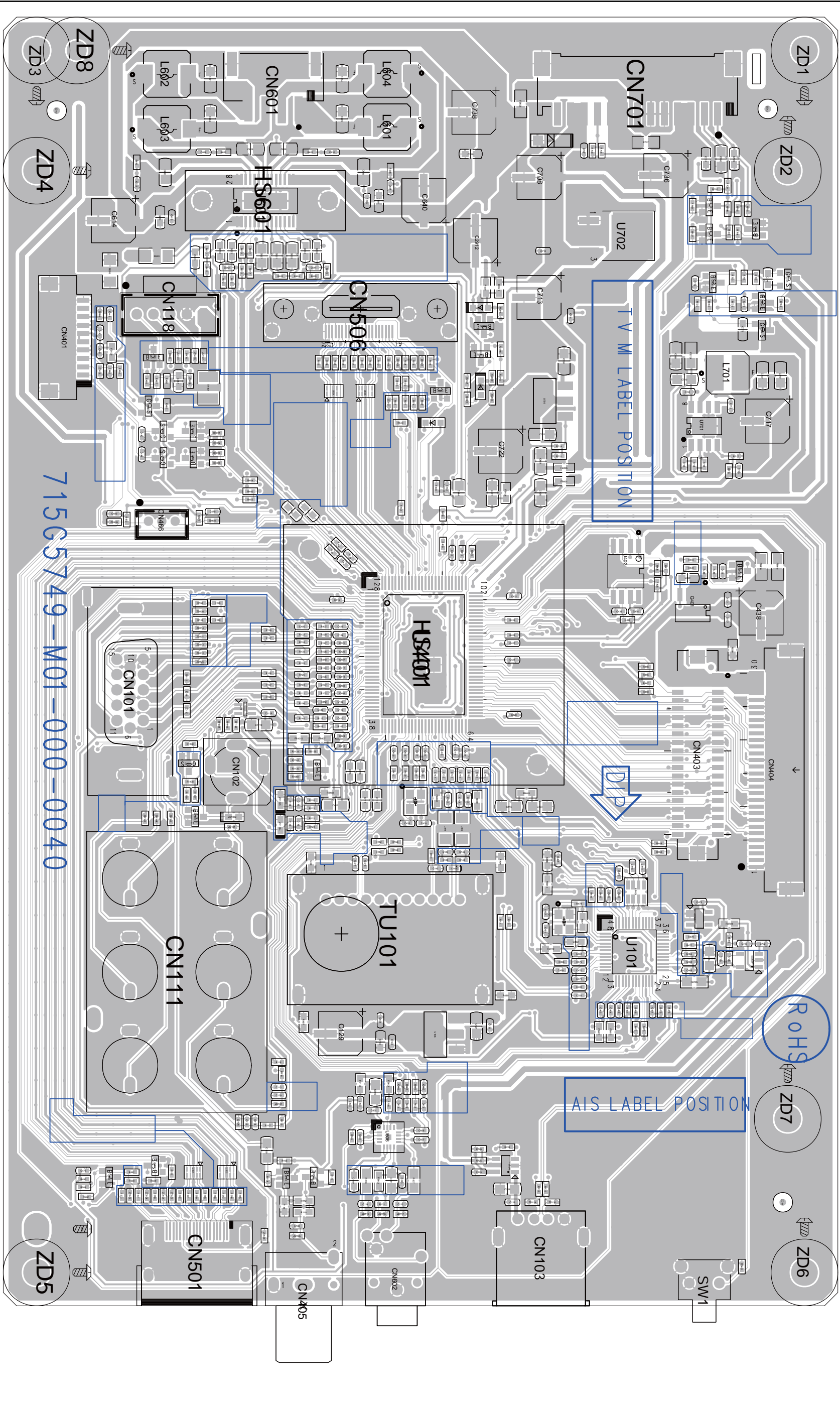

715G5749-M01-000-0040

SSB layout top	
715G5749	
4	201324
19500_519_130409.eps	130409

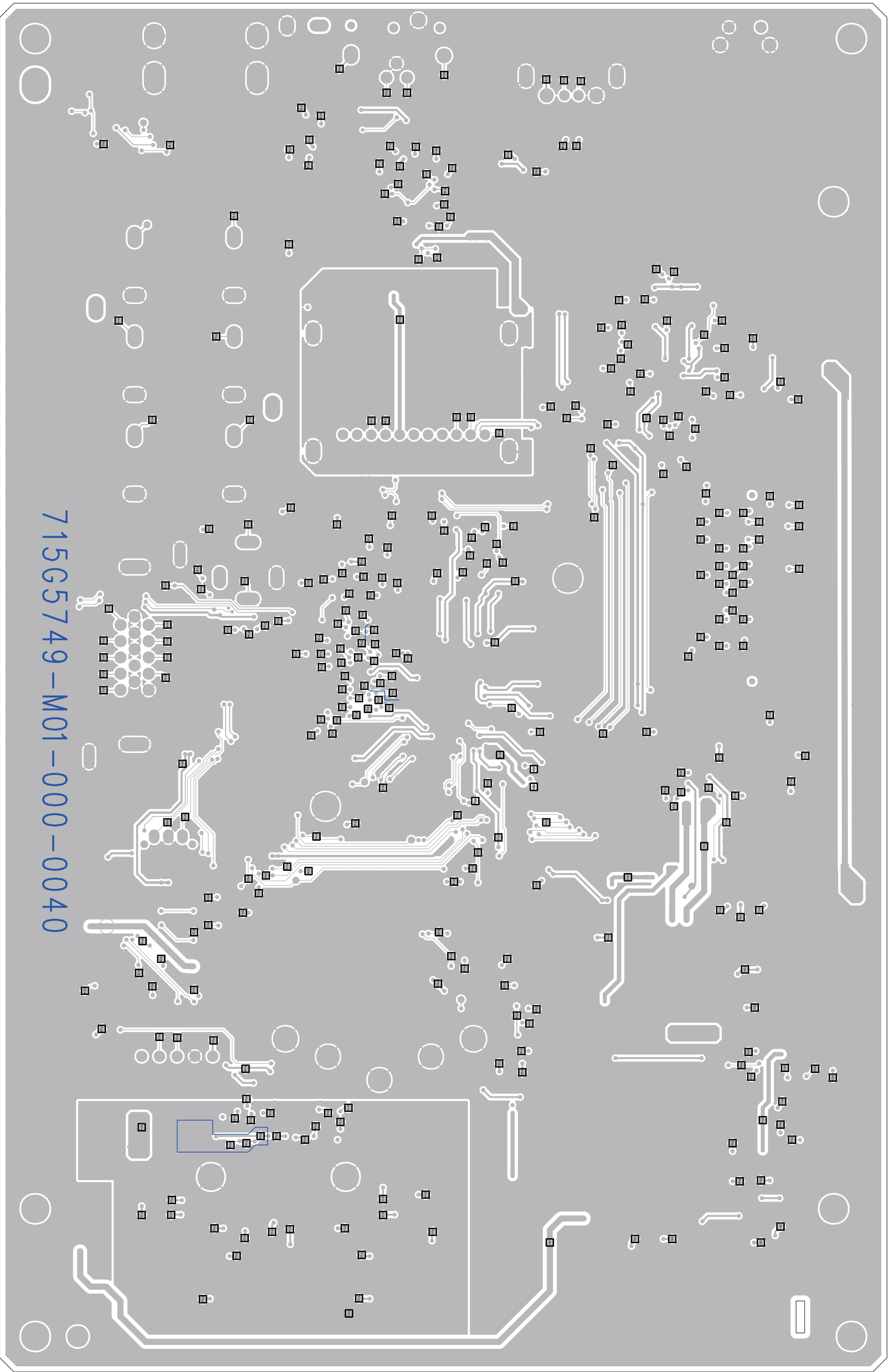

715G5749-M01-000-0040

SSB layout bottom

715G5749

19500\_520\_130409.eps  
130409

10.5 J 715G5772 IR/LED Panel  
10-5-1 IR/LED Panel

J

IR/LED panel

J

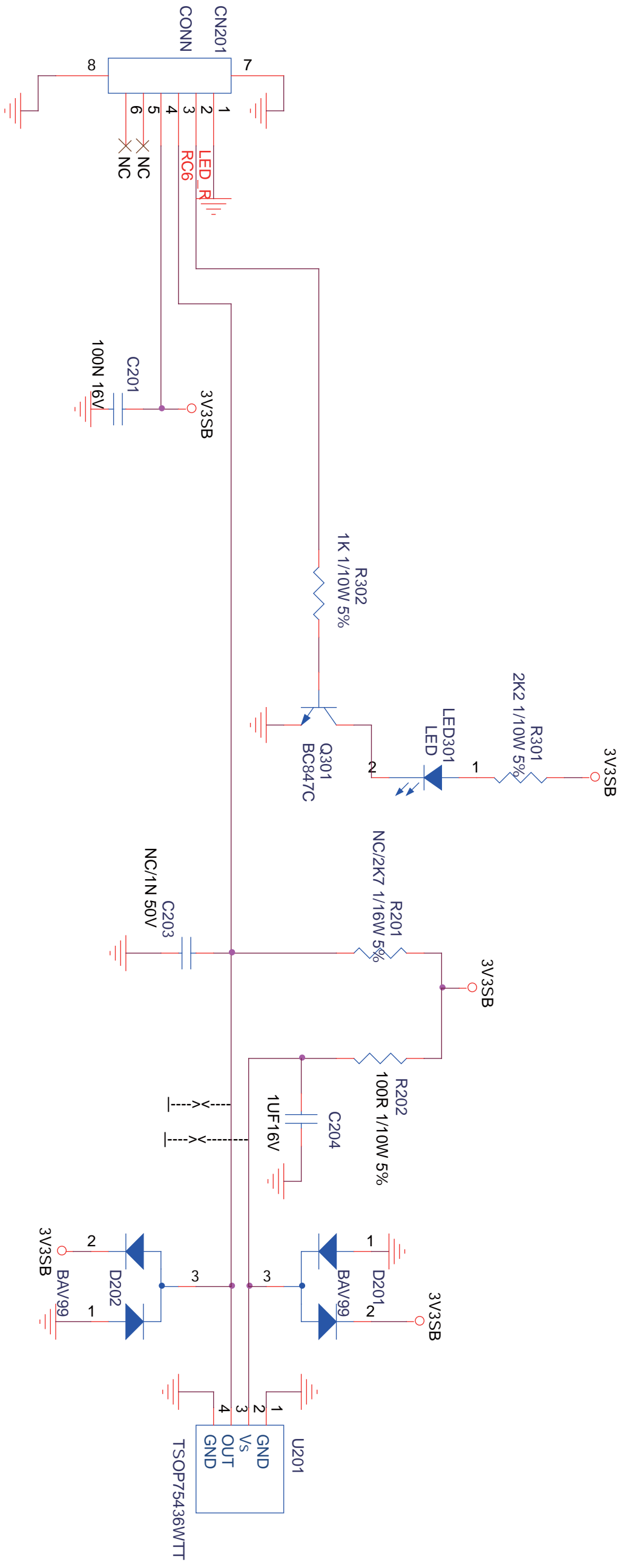

IR/LED panel	715G5772	C	2010/26

Layout IR/LED panel (top side)

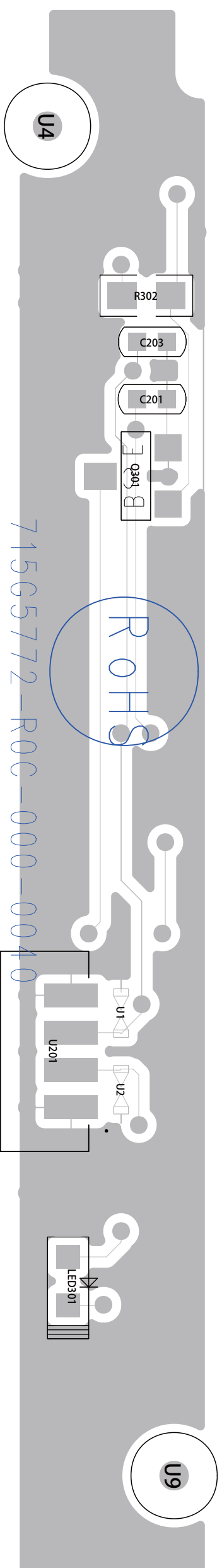

Layout IR/LED panel (bottom side)

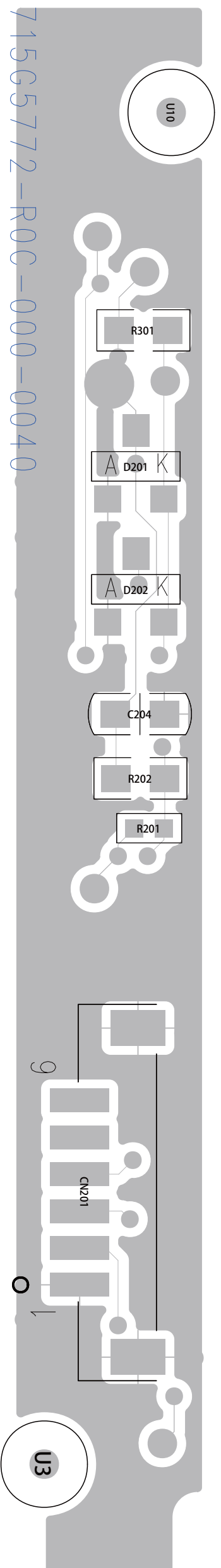

IR/LED panel layout top/bottom	715G5772	19431_525_130226.eps
		130226

10.6 E 715G5771 Keyboard control panel  
10-6-1 Keyboard control panel

**E** Keyboard control panel

**E**

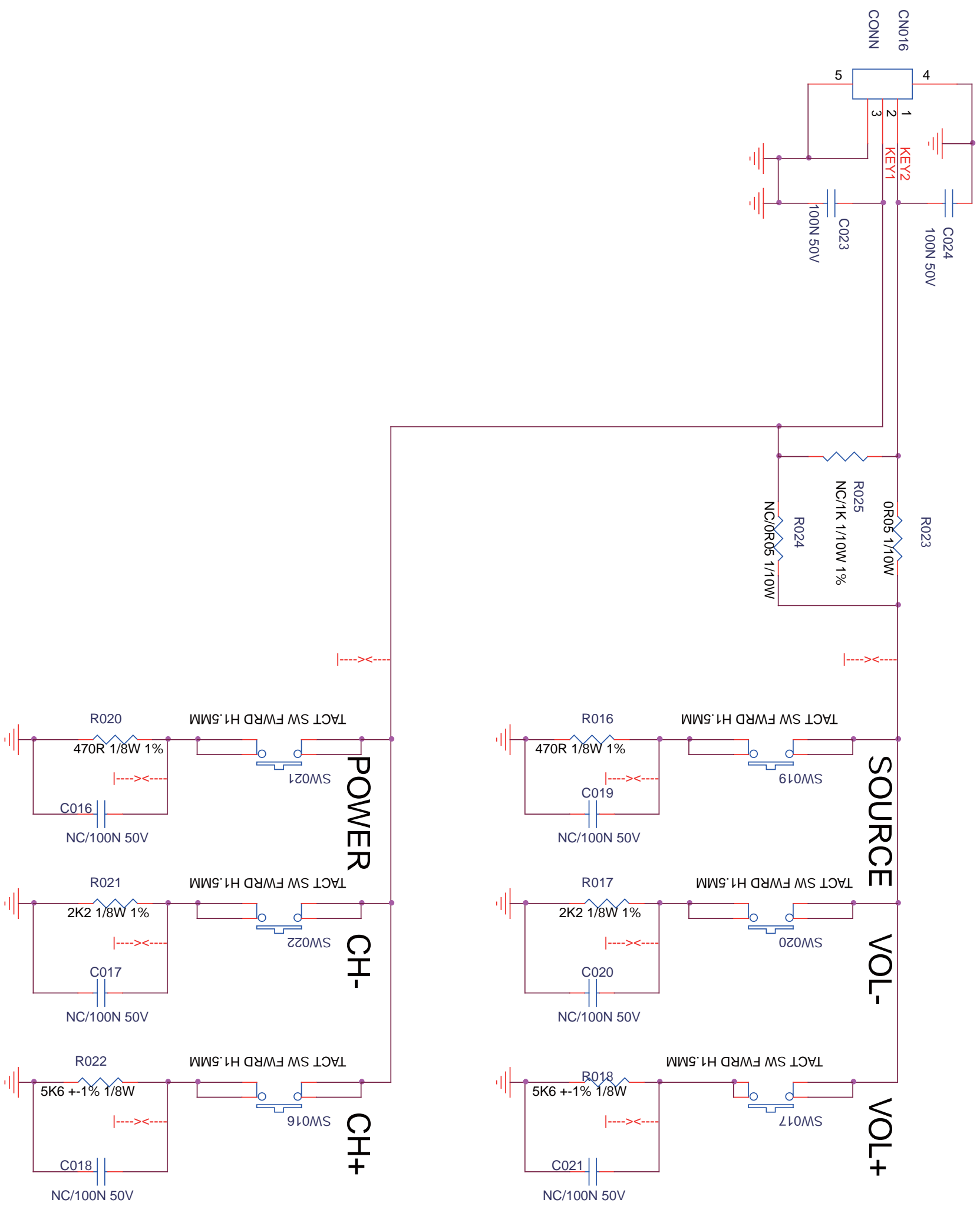

Keyboard control panel

715G5771

19430\_535\_130115.dps  
130115



Layout Keyboard control panel (top side)

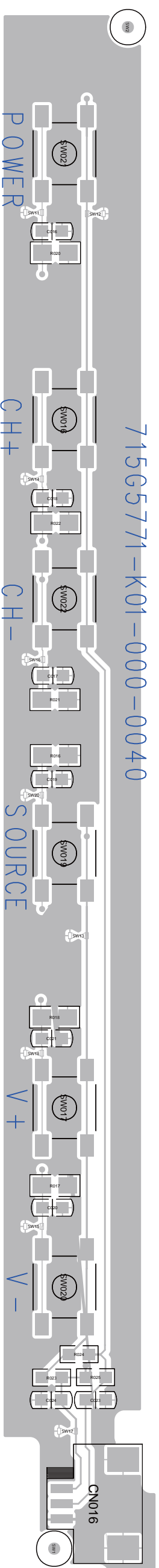

Layout Keyboard control panel (bottom side)

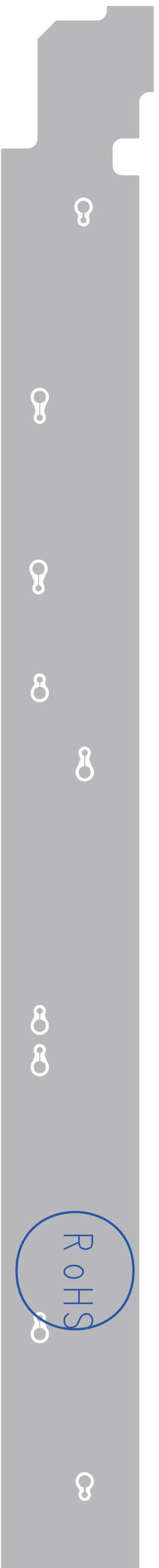

Keyboard control panel layout top/bottom	715G5771				

# 11. Styling Sheets

11.1 3000 series 32"

3000 series 32"

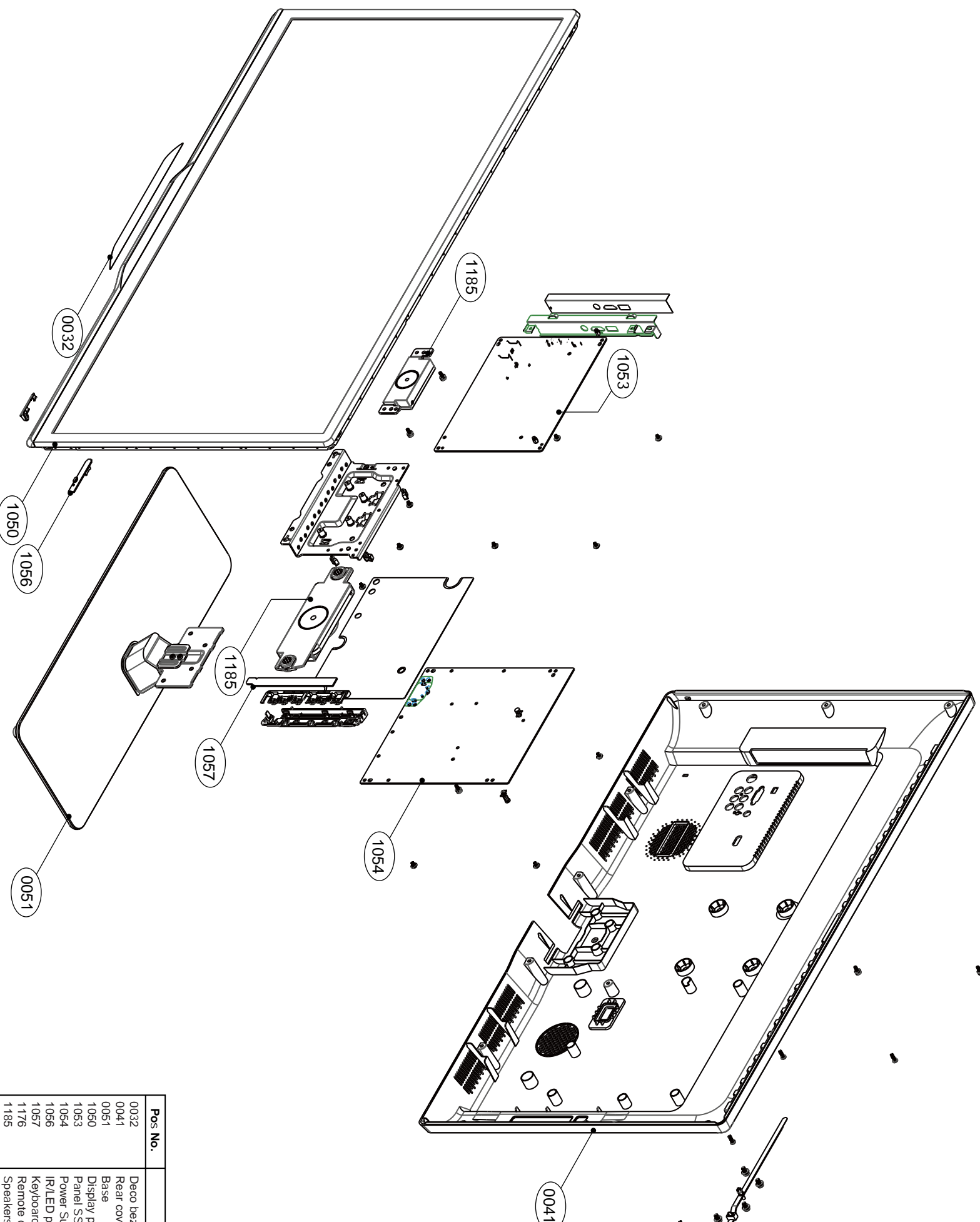

Pos No.	Description	Remarks
0032	Deco bezel	
0041	Rear cover	
0051	Base	
1050	Display panel	
1053	Panel SSB	
1054	Power Supply Unit	
1056	R/LED panel	
1057	Keyboard control panel	
1176	Remote control	
1185	Speakers	Not displayed

FOR ELECTRICAL PARTS/ASSEMBLIES SEE WIRING DIAGRAM CHAPTER 9

3000 series 39"

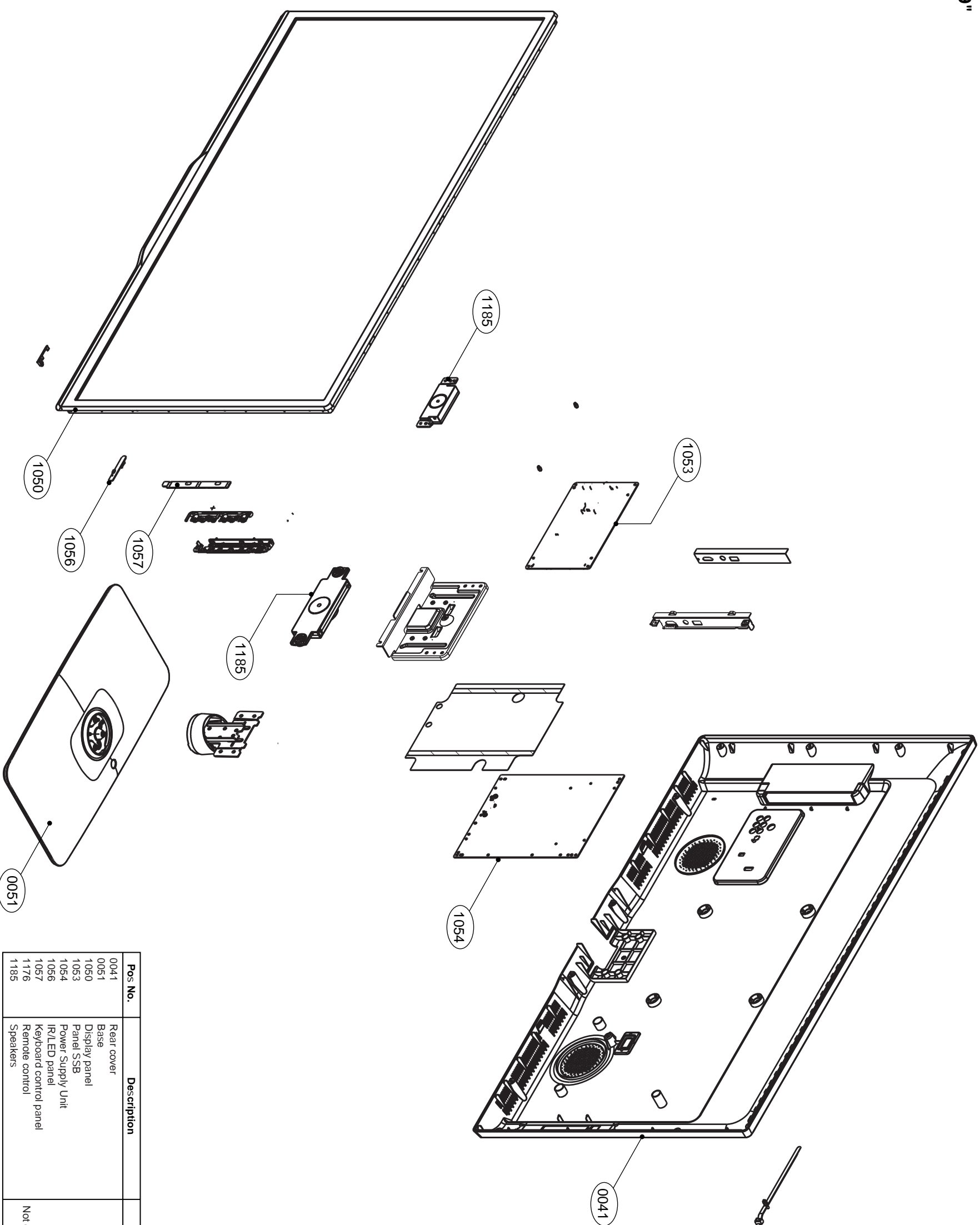

Pos No.	Description	Remarks
0041	Rear cover	
0051	Base	
1050	Display panel	
1053	Panel SSB	
1054	Power Supply Unit	
1056	IR/LED panel	
1057	Keyboard control panel	
1176	Remote control	
1185	Speakers	Not displayed

FOR ELECTRICAL PARTS/ASSEMBLIES SEE WIRING DIAGRAM CHAPTER 9

**3000 series 42"-46"**

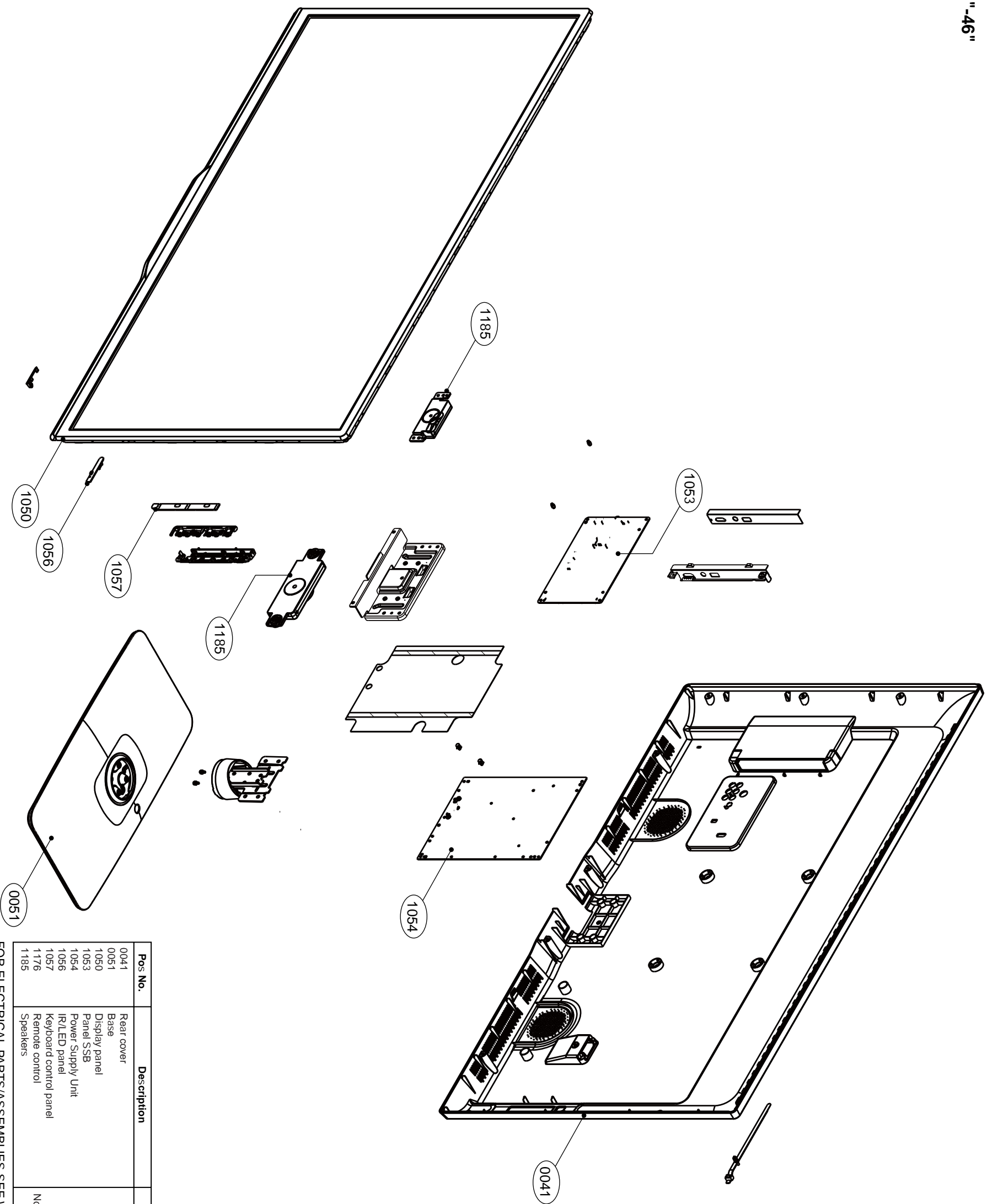

Pos No.	Description	Remarks
0041	Rear cover	
0051	Base	
1050	Display panel	
1053	Panel SSB	
1054	Power Supply Unit	
1056	IR/LED panel	
1057	Keyboard control panel	
1176	Remote control	
1185	Speakers	Not displayed

FOR ELECTRICAL PARTS/ASSEMBLIES SEE WIRING DIAGRAM CHAPTER 9