

0044 D14	2705 A7	2715 F4	2726 E2	2758 G9	2780 E5	2790 E2	3701 E6	3711 E4	3722 C1	3744 G11	3755 B10	3765 C12	3796 E11	5711 E6	6703 C12	7706 C6	7715-2 C11	F720 G8	F743 B9	I703 B6	I713 B3	I723 B9	I733 C10	I743 C12	I753 F4	I763 C6	I773 G9	I783 B2	I794 B12
0045 B1	2706 B4	2716 B3	2727 E2	2759 F8	2781 E5	2791 C7	3702 B6	3712 E3	3723 C1	3746 C6	3756 F3	3766 C14	3797 C5	5712 E4	6704 B6	7707 C5	9717 B5	F721 G2	F744 B9	I704 A6	I714 C8	I724 E2	I734 F12	I744 E6	I754 E2	I764 D13	I774 F9	I784 F4	I795 F6
1735 F2	2707 B4	2717 G4	2728 B3	2762 E13	2782 D12	2792 C8	3703 A6	3713 D7	3724 F1	3747 C6	3757 G3	3767 B12	3798 D6	5720 F9	6710 D8	7708 C13	9718 B13	F722 F2	F745 A9	I705 D6	I715 A7	I725 E1	I735 D8	I745 B4	I755 F4	I765 D13	I775 F7	I785 B4	I796 C12
1736 G2	2708 G4	2718 E3	2729 F3	2764 B2	2783 D7	2793 D13	3704 B6	3714 C6	3725 B4	3748 C5	3758 C10	3768 B13	3799 D6	5701 F4	6711 E8	7709 C13	F708 F2	F731 G8	I706 D5	I716 C3	I726 C2	I736 E8	I746 E13	I756 C1	I766 G9	I776 E4	I786 B4	I797 C12	
1737 F7	2709 D6	2719 F5	2741 F11	2766 A4	2784 D13	2794 C9	3705 E4	3715 B6	3726 F1	3749 A7	3759 D8	3790 B4	5702 F2	5723 D13	6712 B3	7710 B13	F710 G2	F736 G7	I707 E3	I717 B5	I727 B5	I737 C6	I747 D11	I757 D2	I767 F2	I777 D2	I787 C4	I798 E5	
1738 F7	2710 D6	2720 F4	2743 F13	2768 E5	2785 B13	2795 D13	3706 E6	3716 B6	3727 F5	3750 G3	3760 E8	3791 C2	5703 B5	5730 F2	6713 B3	7711 B13	F711 A2	F737 G6	I708 F11	I718 B5	I728 C9	I738 C6	I748 F4	I758 G12	I768 G3	I778 E2	I788 C7	I799 E3	
1739 F5	2711 E2	2721 C1	2753 E13	2769 E5	2786 B4	2796 C10	3707 D6	3717 F3	3729 G9	3751 G8	3761 B12	3792 B3	5704 F7	5731 G2	6714 C5	7712 D9	F712 B2	F738 F2	I709 C3	I719 F3	I729 C5	I739 B6	I749 E4	I759 F12	I769 F3	I779 E2	I789 F3	I790 F3	
1M02 A9	2712 E5	2722 D1	2754 D11	2777 D1	2787 C5	2797 D8	3708 F6	3718 G4	3730 F7	3752 B8	3762 B12	3793 B4	5705 F6	5732 G8	6715 C9	7713 E9	F713 C2	F739 G2	I710 F5	I720 C8	I730 F7	I740 D9	I750 B12	I760 C5	I770 G2	I780 E13	I791 B12	I792 B13	
2702 B5	2713 B7	2723 F8	2755 D11	2778 C5	2788 D1	2798 E8	3709 F5	3720 F7	3741 F11	3753 G8	3763 C12	3794 D11	5707 D1	6701 C6	7714 C5	7714 B5	F714 B5	F741 G8	I711 B4	I721 E4	I731 B11	I741 E9	I751 A12	I761 F8	I771 G3	I781 C13	I792 B13	I793 E3	
2704 C2	2714 C3	2725 F6	2756 G12	2779 E2	2789 D2	2799 D13	3710 B3	3721 C1	3743 F3	3754 C8	3764 C12	3795 C5	5708 E1	6702 B12	7705 B6	7715-1 C9	F715 D10	F742 B9	I712 A5	I722 B2	I732 C6	I742 C12	I752 E13	I762 D11	I772 F8	I782 C13	I793 B13	I794 E3	

SA3 AUDIO

SA3

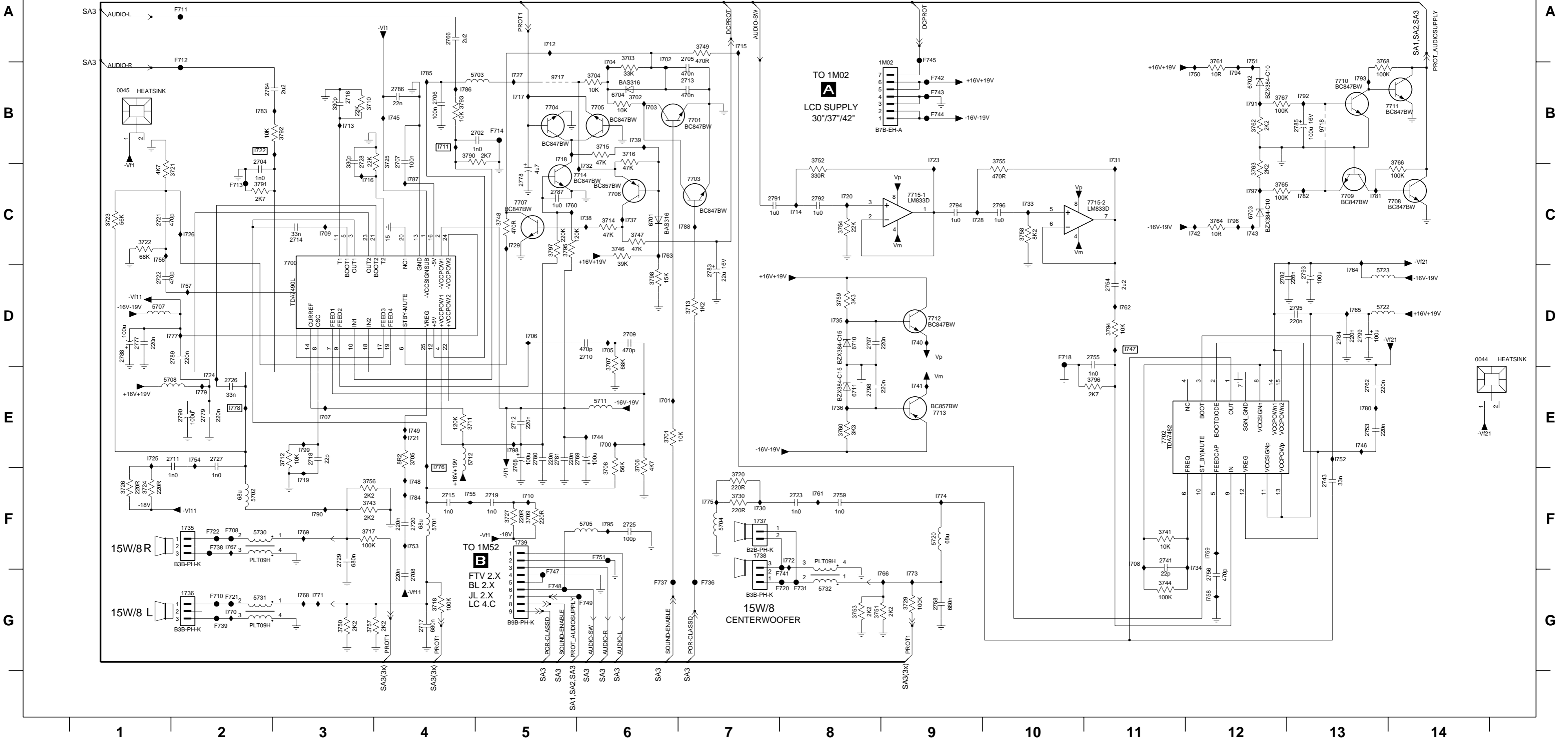

TO 1M02
LCD SUPPLY
30"/37"/42"

TO 1M52
FTV 2.X
BL 2.X
JL 2.X
LC 4.C

15W/8
CENTERWOOFER

0044 HEATSINK



SIDE I/O



A

A

B

B

C

C

D

D

E

E

F

F

1 2 3 4 5 6 7 8

1 2 3 4 5 6 7 8

- I115 D3
- I116 E3
- I117 E3
- I118 E4
- I119 F6
- I120 E6
- I121 C3
- I122 D3
- I123 F3
- I124 F4
- 9936 A6
- 1000 F3
- 1001 B1
- 1002-1 B2
- 1002-2 C2
- 1002-3 C2
- 1003 D3
- 1004 C3
- 1005 C6
- 1006 A3
- 1007 A3
- 1008 E3
- 1009 F4
- 1010 E2
- 1011 C7
- 1012 B2
- 1H01 C8
- 1M36 A7
- 2901 A5
- 2902 A4
- 2903 C4
- 2904 D4
- 2905 F3
- 2906 F5
- 2907 C4
- 2908 D4
- 3902 A4
- 3904 A4
- 3905 B4
- 3906 C4
- 3907 C4
- 3908 D4
- 3909 D4
- 3910 E5
- 3911 F3
- 3912 F5
- 3999 F1
- 5001 C7
- 6900 A3
- 6901 A4
- 6902 A3
- 6903 B3
- 6904 C3
- 6905 C3
- 6906 D3
- 6907 D3
- 6908 F3
- 6909 F3
- 6910 F4
- 6911 F4
- 9900 A4
- 9901 A4
- 9903 F6
- 9904 F6
- F100 F1
- F101 F1
- F102 C7
- F103 C7
- F104 C7
- F105 D7
- F106 D6
- I100 A4
- I101 B5
- I102 A6
- I103 C5
- I104 A2
- I105 B2
- I106 A3
- I107 D5
- I108 B3
- I109 E4
- I110 F5
- I111 A5
- I112 A2
- I113 A2
- I114 C3

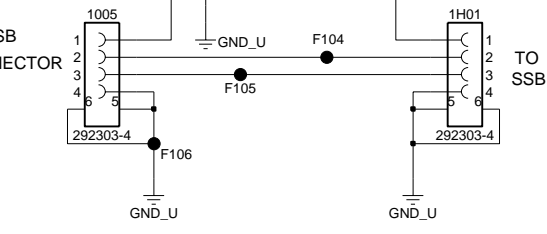
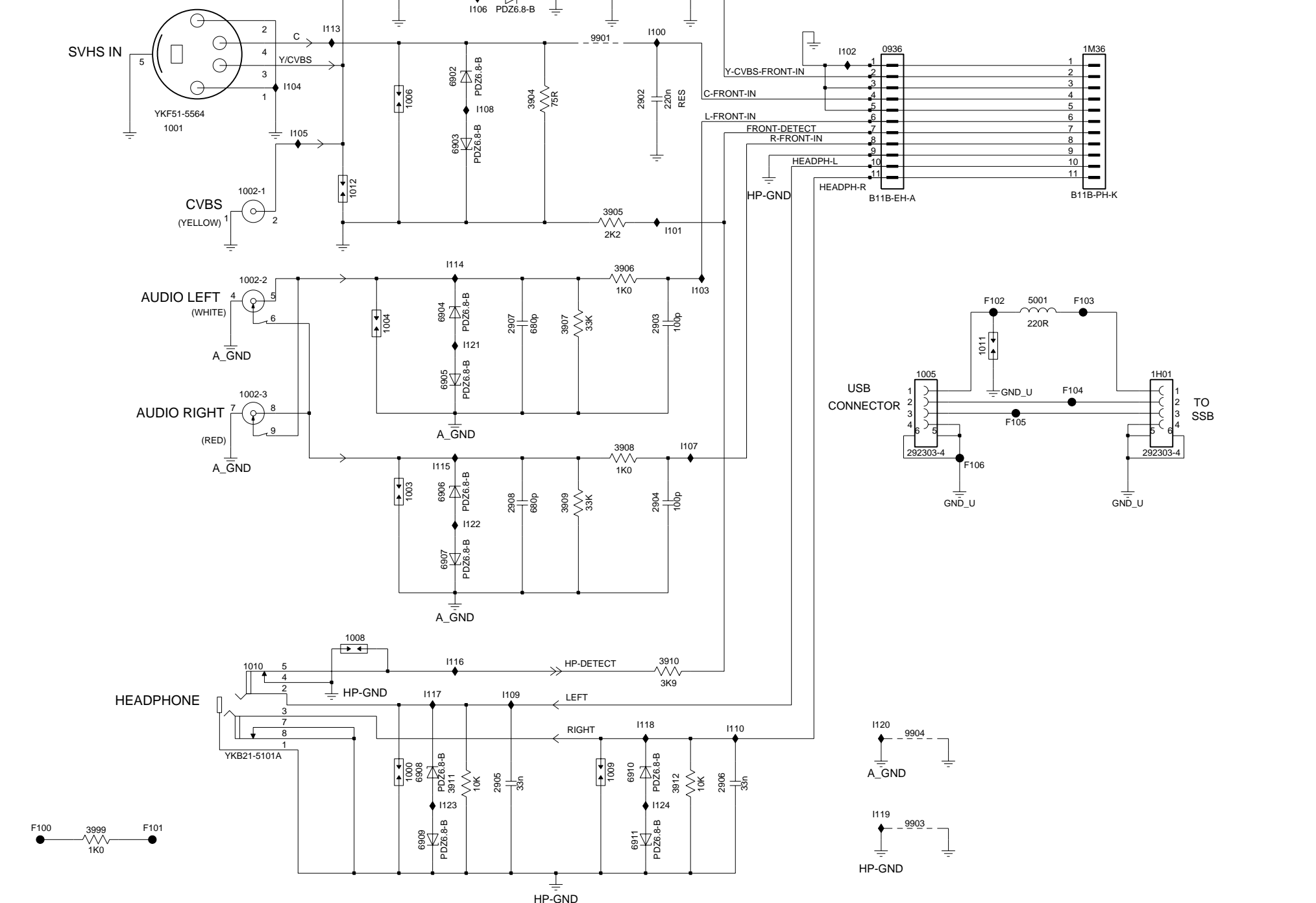

1701 A1	1704 A2	1M01 A4	3004 C1	3007 C1	3999 C4	9003 C2	F003 C4	I007 C1	I010 C2	I102 B1	I105 B3
1702 A1	1705 A1	3002 C2	3005 C1	3008 C1	9001 C3	F001 A4	F004 C4	I008 C1	I100 B1	I103 B2	
1703 A2	1706 A3	3003 C2	3006 C1	3009 C2	9002 C1	F002 A4	I006 C1	I009 C2	I101 B1	I104 B2	

CONTROL BOARD

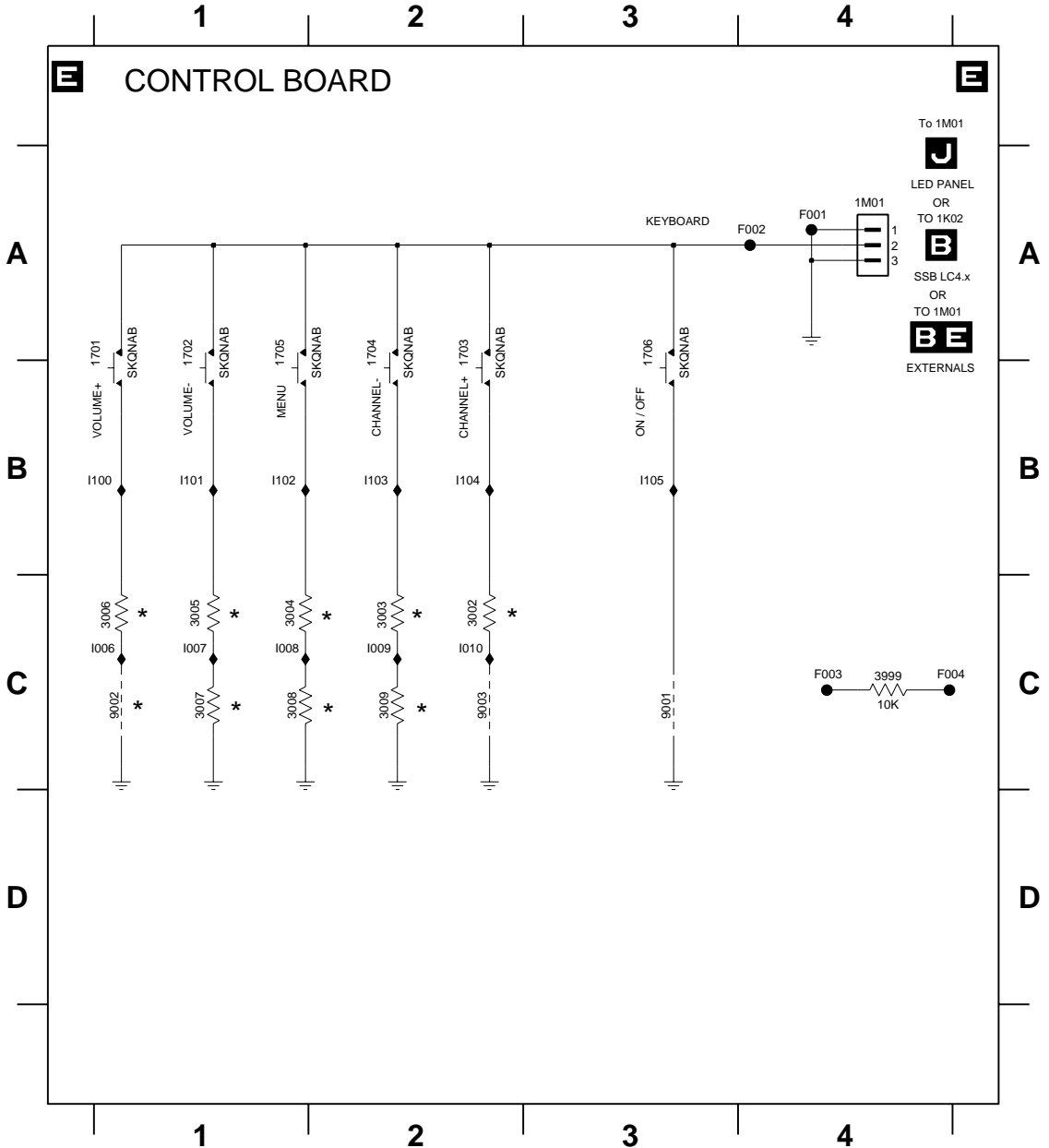

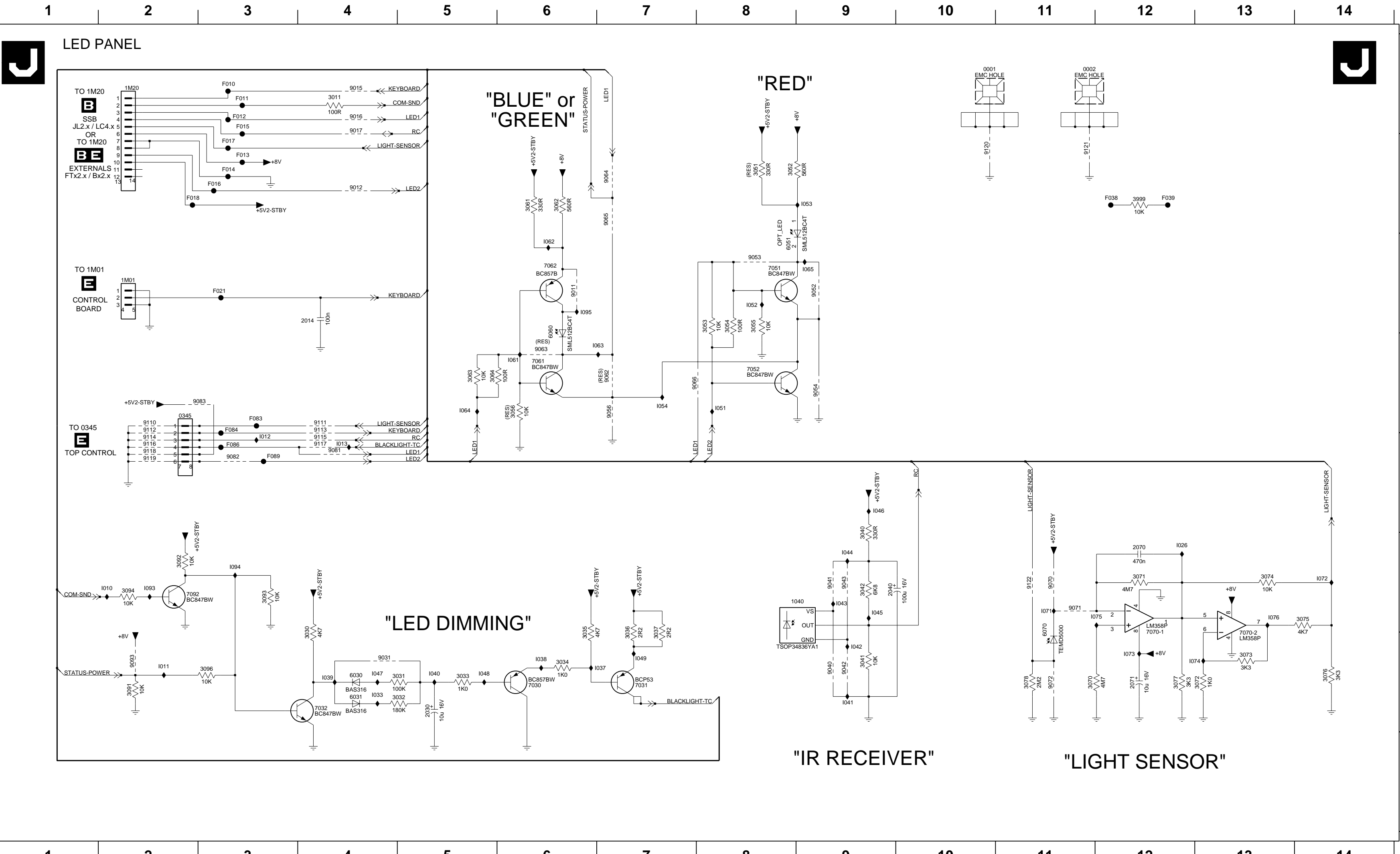

0001 A10	9119 E2
0002 A11	9120 B10
0345 D2	9121 B11
1M01 C2	F010 A3
1M20 A2	F011 A3
2014 C4	F012 A3
2030 G5	F013 B3
2040 F9	F014 B3
2070 F12	F015 A3
2071 G12	F016 B3
3011 A4	F017 B3
3030 G4	F018 B2
3031 G5	F021 C3
3032 G5	F038 B12
3033 G5	F039 B12
3034 G6	F083 D3
3035 G6	F084 D3
3036 G7	F086 E3
3037 G7	F089 E3
3040 F9	I010 F2
3041 G9	I011 G2
3042 F9	I012 E3
3051 B8	I013 E4
3052 B8	I026 F12
3053 C8	I033 G4
3054 C8	I037 G7
3055 C8	I038 G6
3056 D6	I039 G4
3061 B6	I040 G5
3062 B6	I041 G9
3063 D5	I042 G9
3064 D5	I043 F9
3070 G11	I044 F9
3071 F12	I045 F9
3072 G13	I046 E9
3073 G13	I047 G4
3074 F13	I048 G5
3075 F14	I049 G7
3076 G14	I051 D8
3077 G12	I052 C8
3078 G11	I053 B9
3091 G2	I054 D7
3092 F2	I061 D6
3093 F3	I062 C6
3094 F2	I063 D7
3096 G3	I064 D5
3999 B12	I065 C9
6030 G4	I071 F11
6031 G4	I072 F14
6051 C8	I073 G12
6060 C6	I074 G12
6070 G11	I075 F12
7030 G6	I076 F13
7031 G7	I093 F2
7032 G4	I094 F3
7051 C8	I095 C6
7052 D8	
7061 D6	
7062 C6	
7070-1 F12	
7070-2 G13	
7092 F2	
9011 C6	
9012 B4	
9015 A4	
9016 A4	
9017 A4	
9031 G4	
9040 G9	
9041 F9	
9042 G9	
9043 F9	
9052 C9	
9053 C8	
9054 D9	
9056 D7	
9062 D7	
9063 D6	
9064 B7	
9065 B7	
9066 D7	
9070 F11	
9071 F11	
9072 G11	
9081 E4	
9082 E3	
9083 D3	
9093 G2	
9110 D2	
9111 D4	
9112 D2	
9113 D4	
9114 E2	
9115 E4	
9116 E2	
9117 E4	
9118 E2	

A1

MAINS FILTER + STANDBY PART A

A1

A

A

B

B

C

C

D

D

E

E

F

F

G

G

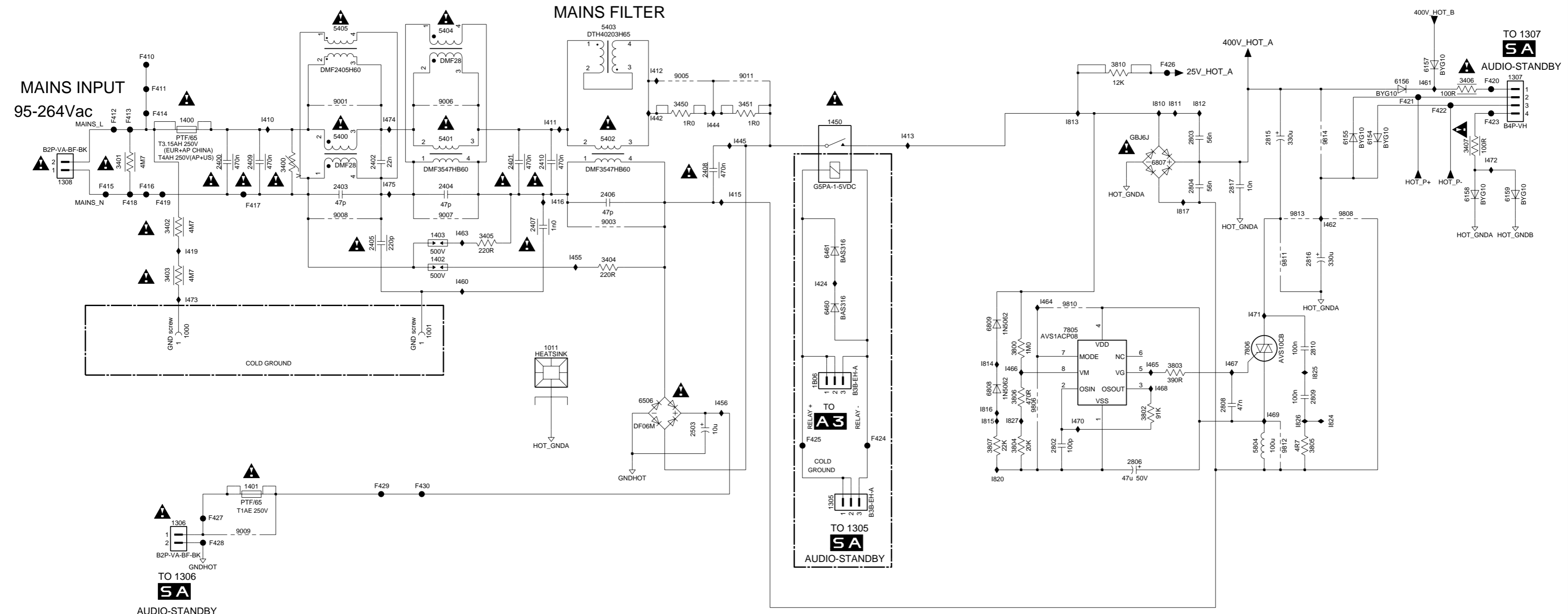

1000 D2	9812 E11
1001 D4	9813 C12
1011 E5	9814 C12
1305 F7	F410 B1
1306 F2	F411 B2
1307 B13	F412 B1
1308 C1	F413 B1
1400 C2	F414 B2
1401 F2	F415 C1
1402 D4	F416 C1
1403 D4	F417 C2
1450 C8	F418 C1
1B06 E7	F419 C2
2400 C2	F420 B13
2401 C5	F421 B13
2402 C3	F422 B13
2403 C3	F423 C13
2404 C4	F424 E8
2405 D3	F425 E7
2406 C6	F426 B10
2407 C5	F427 F2
2408 C6	F428 F2
2409 C2	F429 F4
2410 C5	F430 F4
2503 E6	I410 C3
2802 E9	I411 C5
2803 C11	I412 B6
2804 C11	I413 C8
2806 F10	I415 C7
2808 E11	I416 C5
2809 E12	I419 D2
2810 E12	I424 D7
2815 C11	I442 C6
2816 D12	I444 C6
2817 C11	I445 C7
3400 C3	I455 D5
3401 C1	I456 E7
3402 C2	I460 D4
3403 D2	I461 B13
3404 D6	I462 C12
3405 D4	I463 D4
3406 B13	I464 D9
3407 C13	I465 E10
3450 B6	I466 E9
3451 B7	I467 E11
3800 E9	I468 E10
3802 E10	I469 E11
3803 E11	I470 E10
3804 E9	I471 D11
3805 E12	I472 C13
3806 E9	I473 D2
3807 E9	I474 C4
3810 B10	I475 C4
5400 C3	I810 B10
5401 C4	I811 B11
5402 C6	I812 B11
5403 B6	I813 C10
5404 B4	I814 E9
5405 B3	I815 E9
5804 E11	I816 E9
6154 C12	I817 C11
6155 C12	I820 F9
6156 B13	I824 E12
6157 B13	I825 E12
6158 C13	I826 E12
6159 C13	I827 E9
6460 D7	
6461 D7	
6506 E6	
6807 C10	
6808 E9	
6809 D9	
7805 D10	
7806 E11	
9001 B3	
9003 C6	
9005 B6	
9006 B4	
9007 C4	
9008 C3	
9009 F2	
9011 B7	
9806 E9	
9808 C12	
9810 D10	
9811 D11	

A3

MAINS FILTER + STANDBY PART B

A3

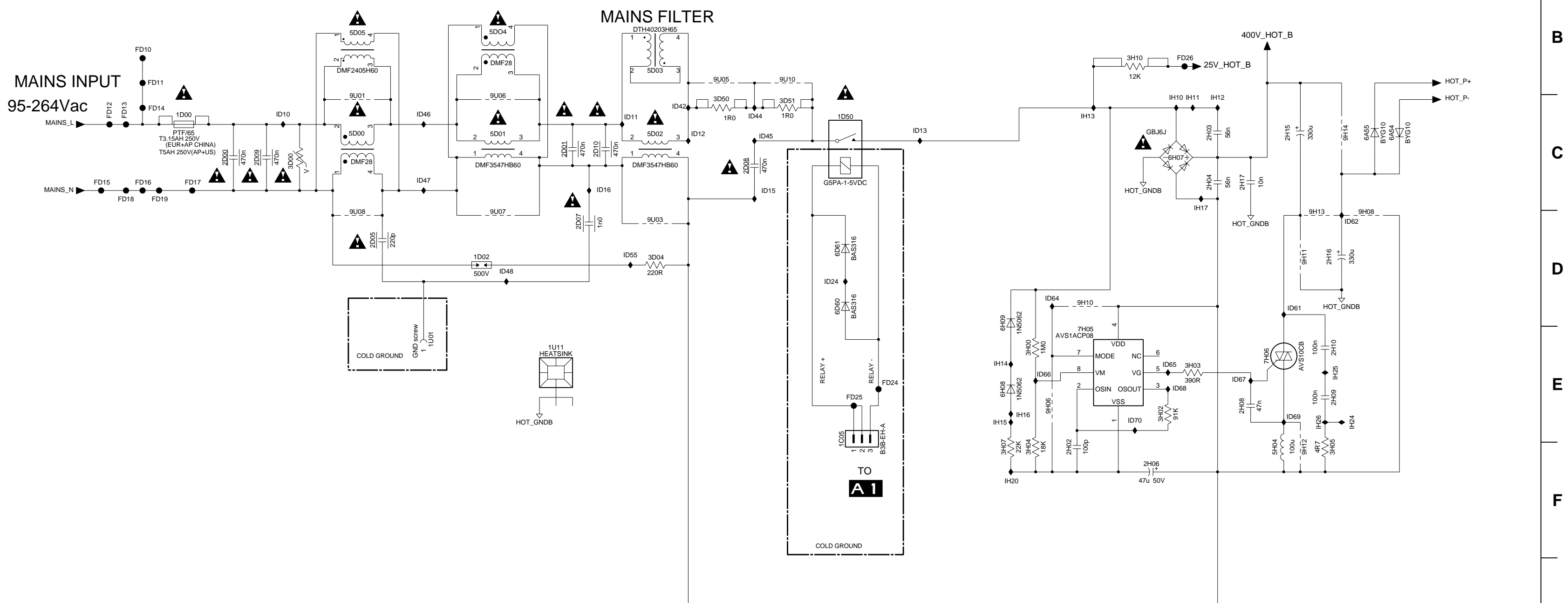

- 1C05 E8
- 1D00 C2
- 1D02 D5
- 1D03 D5
- 1D05 C8
- 1U01 E4
- 1U11 E5
- 2D00 C2
- 2D01 C5
- 2D03 C4
- 2D04 C5
- 2D05 D4
- 2D06 C6
- 2D07 D6
- 2D08 C7
- 2D09 C3
- 2D10 C6
- 2H02 F10
- 2H03 C11
- 2H04 C11
- 2H06 F10
- 2H08 E11
- 2H09 E12
- 2H10 E12
- 2H15 C12
- 2H16 D12
- 2H17 C11
- 3D00 C3
- 3D04 D6
- 3D05 D5
- 3D50 C7
- 3D51 C7
- 3H00 E9
- 3H02 E11
- 3H03 E11
- 3H04 F9
- 3H05 F12
- 3H07 F9
- 3H10 B10
- 5D00 C4
- 5D01 C5
- 5D02 C6
- 5D03 B6
- 5D05 B4
- 5D0A B5
- 5H04 F12
- 6A54 C13
- 6A55 C12
- 6D60 D8
- 6D61 D8
- 6H07 C11
- 6H08 E9
- 6H09 D9
- 7H05 E10
- 7H06 E11
- 9H06 E10
- 9H08 D12
- 9H10 D10
- 9H11 D12
- 9H12 F12
- 9H13 D12
- 9H14 C12
- 9U01 C4
- 9U03 D6
- 9U05 B7
- 9U06 C5
- 9U07 D5
- 9U08 D4
- 9U10 B7
- FD10 B2
- FD11 B2
- FD12 C1
- FD13 C2
- FD14 C2
- FD15 C1
- FD16 C2
- FD17 C2
- FD18 C2
- FD19 C2
- FD24 E8
- FD25 E8
- FD26 B11
- ID10 C3
- ID11 C6
- ID12 C7
- ID13 C8
- ID15 C7
- ID16 C6
- ID24 D8
- ID28 D8
- ID42 C6
- ID43 C7
- ID44 C7
- ID45 C7
- ID46 C4
- ID47 C4
- ID48 D5
- ID55 D6
- ID61 D12
- ID62 D12
- ID63 D5
- ID64 D10
- ID65 E11
- ID66 E10
- ID67 E11
- ID68 E11
- ID69 E12
- ID70 E10
- IH10 C11
- IH11 C11
- IH12 C11
- IH13 C10
- IH14 E9
- IH15 E9
- IH16 E9
- IH17 C11
- IH20 F9
- IH24 E12
- IH25 E12
- IH26 E12

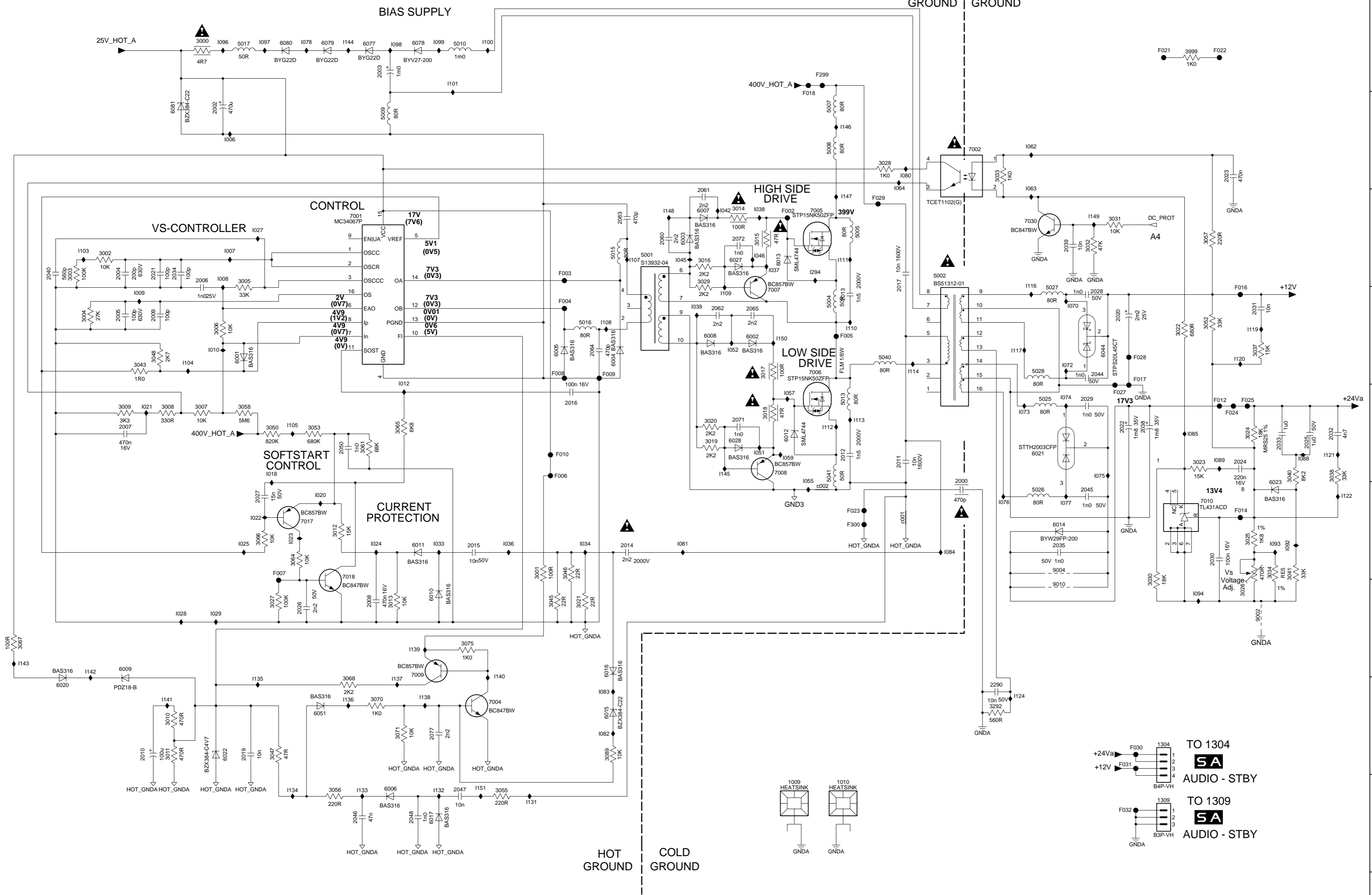

1009	I09	1036	F6
1010	I9	1037	F5
1304	H12	1038	C8
1309	I12	1039	H7
2000	F10	1042	C8
2002	B3	1045	F7
2003	A4	1046	C7
2004	C2	1051	E8
2005	D2	1052	D8
2006	C3	1055	E9
2007	E2	1057	B9
2008	G4	1059	B9
2009	D2	1062	B1
2010	H2	1063	B11
2011	E10	1064	B10
2012	E9	1070	D12
2013	D9	1072	D11
2014	F7	1073	E11
2015	F5	1074	E11
2016	E6	1075	E12
2017	C10	1076	F11
2019	H3	1077	F11
2020	D12	1078	A4
2021	C2	1080	B10
2022	E12	1081	F8
2023	B13	1082	H7
2024	E13	1083	H7
2025	E14	1084	F10
2026	G4	1085	E13
2027	F3	1088	E14
2028	D12	1089	E13
2029	E12	1092	F14
2030	F13	1093	F14
2031	D13	1094	G13
2032	E14	1096	A3
2033	E14	1097	A3
2034	C2	1098	A5
2035	F11	1099	A5
2038	E12	1100	A6
2039	C11	1101	A5
2040	C1	1103	C1
2044	D12	1104	D2
2045	F12	1105	E4
2046	I4	1107	C7
2047	I5	1108	D7
2048	I5	1109	D8
2050	E4	1110	D9
2060	C7	1111	C9
2061	C8	1112	E9
2062	D8	1113	E9
2063	C7	1114	D10
2064	D7	1116	C11
2065	D8	1117	D11
2071	E8	1119	D13
2072	C8	1120	D3
2073	H5	1121	F14
2077	H5	1122	F14
2290	H11	1124	H6
3000	A3	1124	H11
3001	F6	1131	I6
3002	C2	1132	I5
3003	C1	1133	H3
3004	D1	1134	I4
3005	C3	1135	H3
3006	D3	1136	H4
3007	E3	1137	H5
3008	E2	1138	H5
3009	E2	1139	G5
3010	H2	1140	G6
3011	H2	1141	G11
3012	F4	1142	G1
3013	G5	1143	G1
3014	C8	1144	G1
3015	C8	1145	E8
3016	C8	1146	B9
3017	D8	1147	C9
3018	E8	1148	C7
3019	E8	1149	C12
3020	E8	1150	D9
3021	G6	1151	I5
3022	D13	1151	I5
3023	E13	1151	I5
3024	E13	1151	I5
3025	F13	1151	I5
3026	G13	1151	I5
3027	G3	1151	I5
3028	B10	1151	I5
3029	C8	1151	I5
3030	G12	1151	I5
3031	C12	1151	I5
3032	C12	1151	I5
3033	B11	1151	I5
3034	F14	1151	I5
3037	D13	1151	I5
3038	E14	1151	I5
3040	E14	1151	I5
3041	F14	1151	I5
3043	D2	1151	I5
3045	G6	1151	I5
3046	F6	1151	I5
3047	H3	1151	I5
3048	D2	1151	I5
3050	E3	1151	I5
3052	D13	1151	I5
3053	E4	1151	I5
3055	I6	1151	I5
3056	I4	1151	I5
3057	C13	1151	I5
3058	E3	1151	I5
3061	E4	1151	I5
3064	F4	1151	I5
3065	E5	1151	I5
3066	F3	1151	I5
3067	G1	1151	I5
3068	H4	1151	I5

TO 1304

SA AUDIO - STBY

TO 1309

SA AUDIO - STBY

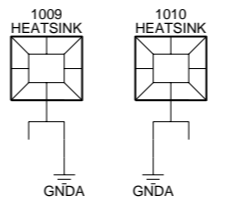

A 4 SUPPLY PART B

A 4

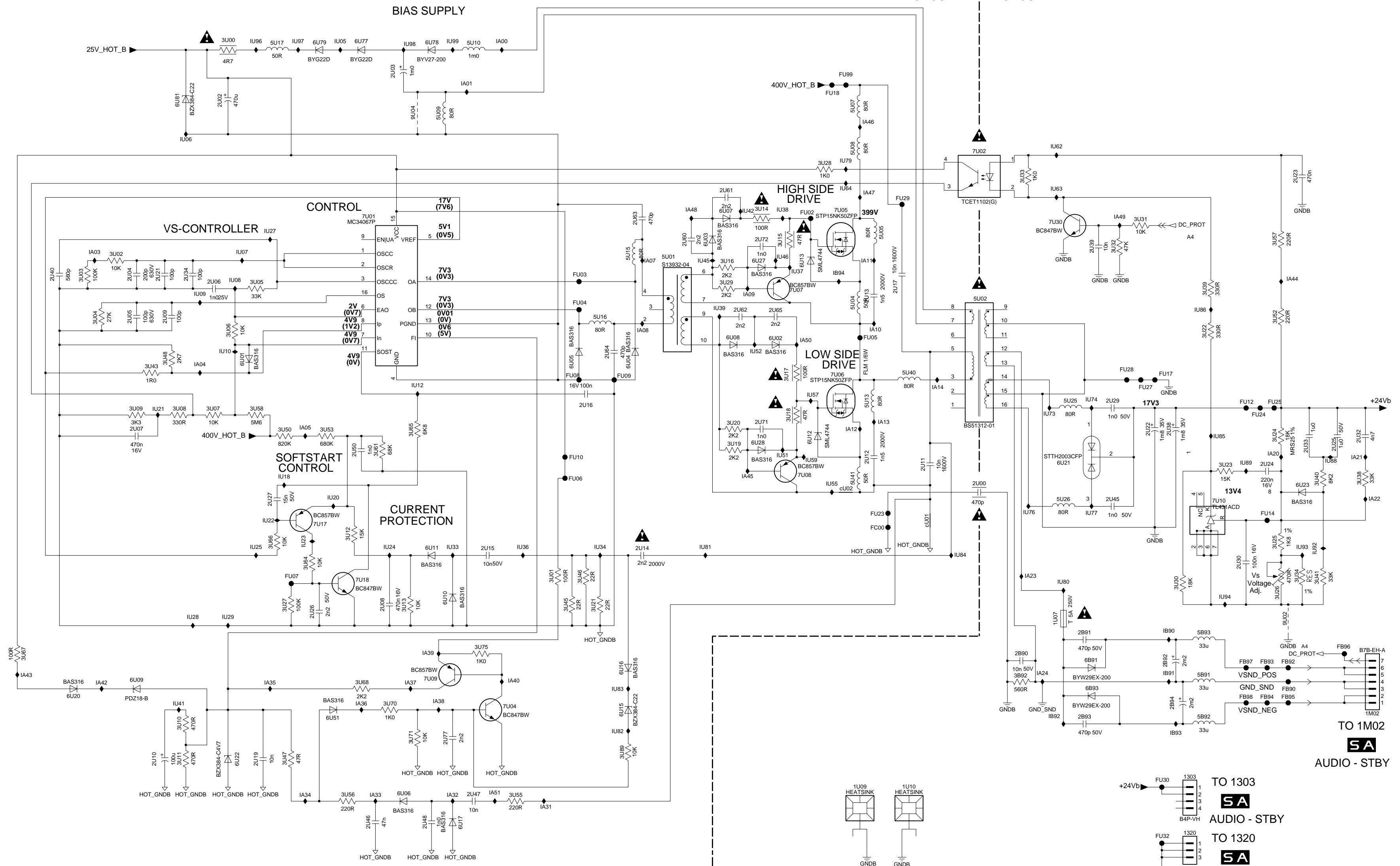

1303 H2	3U70 H4	IA32 I5
1320 H2	3U71 H5	IA33 I4
1M02 H14	3U75 G5	IA34 I3
1U07 G11	3U89 H7	IA35 H3
1U09 I9	5B91 G13	IA36 H4
1U10 I10	5B92 H13	IA37 H5
2B90 G11	5B93 G13	IA38 H5
2B91 G11	5U01 C7	IA39 G5
2B92 G12	5U02 D10	IA40 H6
2B93 H11	5U04 D9	IA42 H1
2B94 H12	5U05 C9	IA43 G1
2U00 F10	5U07 B9	IA44 C14
2U02 B3	5U08 B9	IA45 E8
2U03 A4	5U09 B5	IA46 B9
2U04 C2	5U10 A5	IA47 C9
2U05 D2	5U13 E9	IA48 C7
2U06 C3	5U15 C7	IA49 C12
2U07 E2	5U16 D6	IA50 D9
2U08 G4	5U17 A3	IA51 I5
2U09 D4	5U25 E11	IB90 G12
2U10 H2	5U26 F11	IB91 G12
2U11 E10	5U40 D10	IB92 H11
2U12 E9	5U41 E9	IB93 H12
2U13 D9	6B91 G11	IB94 C9
2U14 F7	6B93 H11	IU05 A4
2U15 F5	6U01 D3	IU06 B2
2U16 E6	6U02 D8	IU07 C3
2U17 D10	6U03 C8	IU08 C3
2U19 H3	6U04 D7	IU09 D2
2U21 C2	6U05 D6	IU10 D3
2U22 E12	6U06 I4	IU12 E5
2U23 B14	6U07 C8	IU18 E3
2U24 E13	6U08 D8	IU20 F4
2U25 E14	6U09 H2	IU21 E2
2U27 F3	6U11 F5	IU23 F3
2U29 E12	6U12 E9	IU24 F4
2U30 F13	6U13 C9	IU25 F3
2U32 E14	6U15 H7	IU27 C3
2U33 E14	6U16 G7	IU28 G2
2U34 C2	6U17 I5	IU29 G3
2U38 E12	6U20 H1	IU33 F5
2U39 C12	6U21 E11	IU34 F6
2U40 C1	6U22 H3	IU36 F6
2U45 F12	6U23 F14	IU37 C8
2U46 I4	6U27 C8	IU38 C8
2U47 I5	6U28 E8	IU39 D8
2U48 I5	6U51 H4	IU41 H2
2U50 E4	6U77 A4	IU42 C8
2U60 C7	6U78 A5	IU45 C8
2U61 C8	6U79 A4	IU46 C8
2U62 D8	6U81 B2	IU51 E8
2U63 C7	7U01 C4	IU52 D8
2U64 D7	7U02 B10	IU55 F9
2U65 D8	7U04 H5	IU57 E9
2U71 E8	7U05 C9	IU59 E9
2U72 C8	7U06 D9	IU62 B11
2U77 H5	7U07 D8	IU63 C11
3B92 G11	7U08 E8	IU64 C9
3U00 A3	7U09 G5	IU73 E11
3U01 F6	7U10 F13	IU74 E11
3U02 C2	7U17 F4	IU76 F11
3U03 C1	7U18 G4	IU77 F11
3U04 D1	7U30 C11	IU79 B9
3U05 C3	9U02 G13	IU80 G11
3U06 D3	9U04 B5	IU81 F8
3U07 E3	FB90 H13	IU82 H7
3U08 E2	FB92 G13	IU83 H7
3U09 E2	FB93 G13	IU84 F10
3U10 H2	FB94 H13	IU85 E13
3U11 H2	FB95 H13	IU86 D13
3U12 F4	FB96 G14	IU88 E14
3U13 G5	FB97 G13	IU89 E13
3U14 C8	FB98 H13	IU92 F14
3U15 C8	FC00 F9	IU93 F14
3U16 C8	FU02 C9	IU94 G13
3U17 D8	FU03 C6	IU96 A3
3U18 E8	FU04 D6	IU97 A3
3U19 E8	FU05 D9	IU98 A5
3U20 E8	FU06 E6	IU99 A5
3U21 G6	FU07 F3	cU01 F10
3U22 D13	FU08 D6	cU02 F9
3U23 E13	FU09 D7	
3U24 E13	FU10 E6	
3U25 F13	FU12 E13	
3U26 G13	FU14 F13	
3U27 G3	FU17 D12	
3U28 B9	FU18 B9	
3U29 C8	FU23 F9	
3U30 G12	FU24 E13	
3U31 C12	FU25 E13	
3U32 C12	FU27 E12	
3U33 B11	FU28 D12	
3U34 F14	FU29 C10	
3U38 E14	FU30 I12	
3U39 D13	FU32 I12	
3U40 E14	FU99 A9	
3U41 F14	IA00 A5	
3U43 D2	IA01 A5	
3U45 G6	IA03 C1	
3U46 F6	IA04 D2	
3U47 H3	IA05 E3	
3U48 D2	IA07 C7	
3U50 E3	IA08 D7	
3U52 D13	IA09 D8	
3U53 E4	IA10 D9	
3U55 I6	IA11 C9	
3U56 I4	IA12 E9	
3U57 C13	IA13 E9	
3U58 E3	IA14 E10	
3U61 E4	IA20 E13	
3U64 F4	IA21 E14	
3U65 E5	IA22 F14	
3U66 F3	IA23 F11	
3U67 G1	IA24 G11	
3U68 H4	IA31 I6	

TO 1M02
SA
AUDIO - STBY

+24Vb FU30
SA
TO 1303
AUDIO - STBY

FU32
SA
TO 1320
AUDIO - STBY

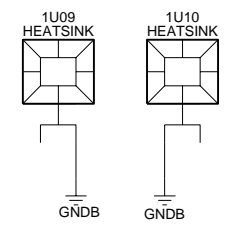

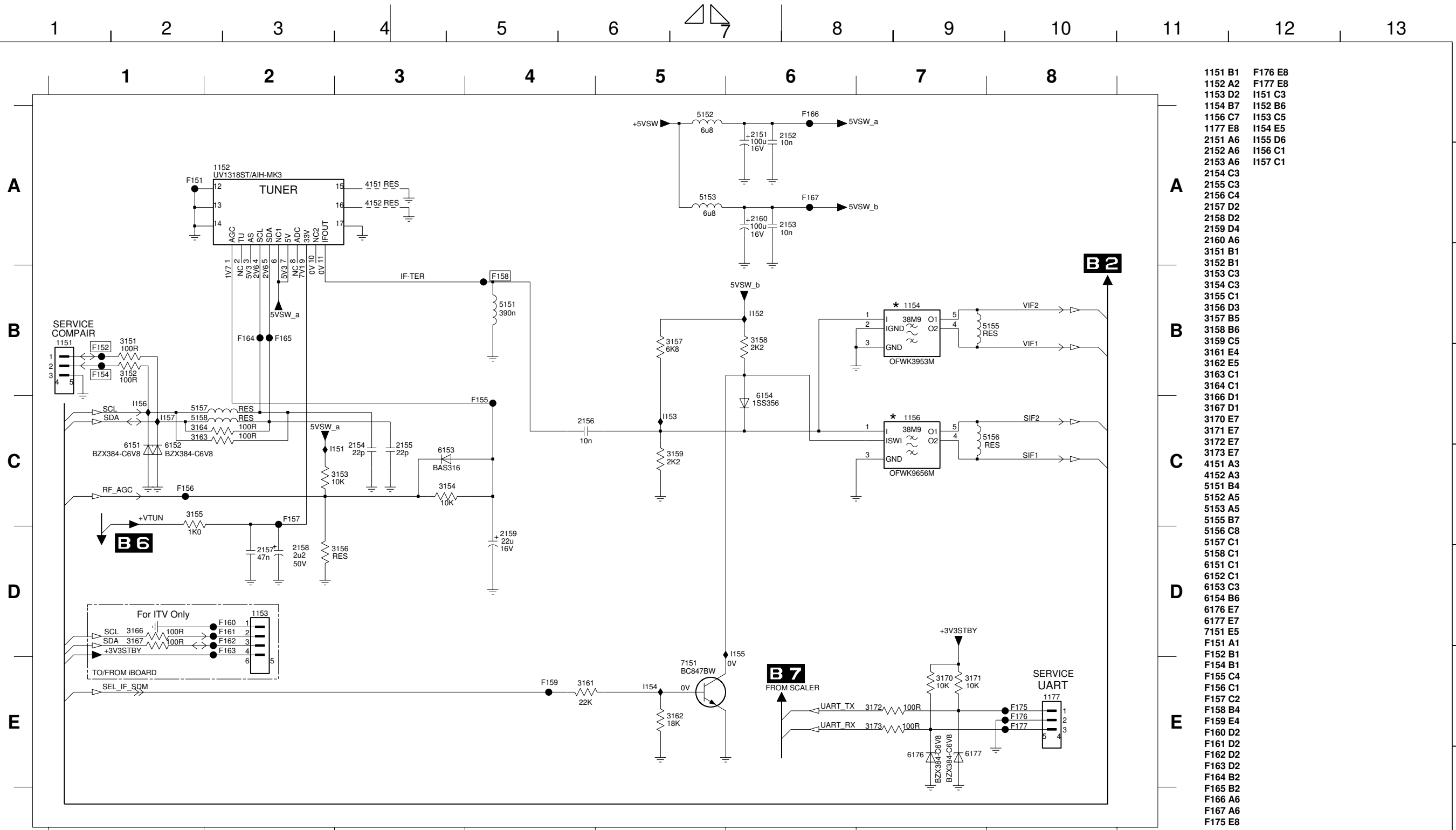

- 1151 B1
- 1152 A2
- 1153 D2
- 1154 B7
- 1156 C7
- 1177 E8
- 2151 A6
- 2152 A6
- 2153 A6
- 2154 C3
- 2155 C3
- 2156 C4
- 2157 D2
- 2158 D2
- 2159 D4
- 2160 A6
- 3151 B1
- 3152 B1
- 3153 C3
- 3154 C3
- 3155 C1
- 3156 D3
- 3157 B5
- 3158 B6
- 3159 C5
- 3161 E4
- 3162 E5
- 3163 C1
- 3164 C1
- 3166 D1
- 3167 D1
- 3170 E7
- 3171 E7
- 3172 E7
- 3173 E7
- 4151 A3
- 4152 A3
- 5151 B4
- 5152 A5
- 5153 A5
- 5155 B7
- 5156 C8
- 5157 C1
- 5158 C1
- 6151 C1
- 6152 C1
- 6153 C3
- 6154 B6
- 6176 E7
- 6177 E7
- 7151 E5
- F151 A1
- F152 B1
- F154 B1
- F155 C4
- F156 C1
- F157 C2
- F158 B4
- F159 E4
- F160 D2
- F161 D2
- F162 D2
- F163 D2
- F164 B2
- F165 B2
- F166 A6
- F167 A6
- F175 E8
- F176 E8
- F177 E8
- I151 C3
- I152 B6
- I153 C5
- I154 E4
- I155 A5
- I156 B7
- I157 C1
- I158 C1
- I159 E4
- I160 D2
- I161 D2
- I162 D2
- I163 D2
- I164 B2
- I165 B2
- I166 A6
- I167 A6
- I175 E8

B1 TUNER & IF

SSB SCART LC04SD2.1 MULTIPLE 12NC :- 3139_123_61163_01
 SSB SCART LC04SD2.1 SINGLE 12NC :- 3139_123_61173_01
 CELL 12NC :- 8239_125_12083

"150" ~ "199"

PHILIPS

All rights reserved. Reproduction in whole or in parts is prohibited without the written consent of the copyright owner.

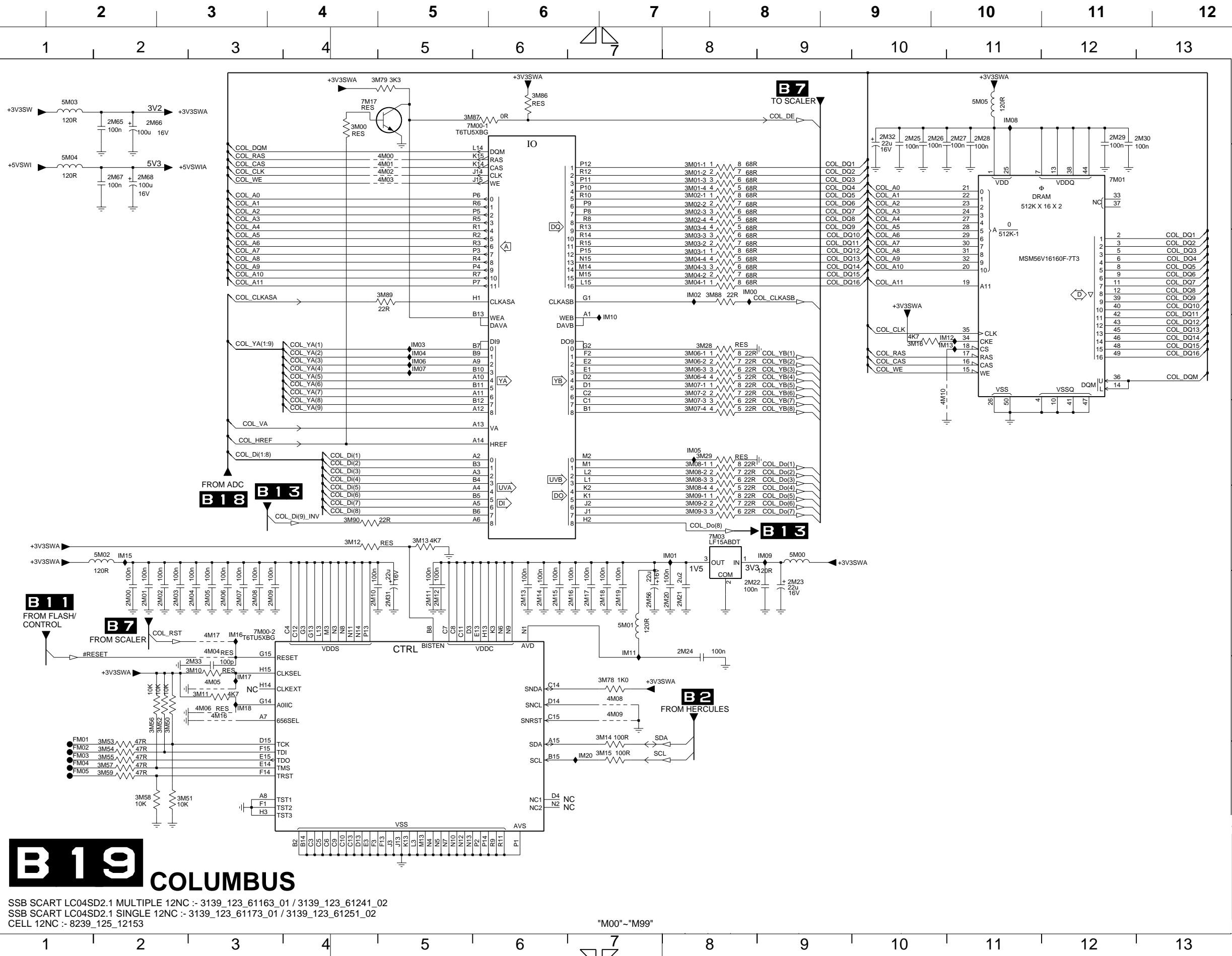

B19 COLUMBUS

SSB SCART LC04SD2.1 MULTIPLE 12NC :- 3139_123_61163_01 / 3139_123_61241_02
 SSB SCART LC04SD2.1 SINGLE 12NC :- 3139_123_61173_01 / 3139_123_61251_02
 CELL 12NC :- 8239_125_12153

"M00"-"M99"

- 2M00 E2
- 2M01 E2
- 2M02 E3
- 2M03 E3
- 2M04 E3
- 2M05 E3
- 2M06 E3
- 2M07 E3
- 2M08 E3
- 2M09 E4
- 2M10 E4
- 2M11 E5
- 2M12 E5
- 2M13 E6
- 2M14 E6
- 2M15 E6
- 2M16 E6
- 2M17 E6
- 2M18 E7
- 2M19 E7
- 2M20 E7
- 2M21 E7
- 2M22 E8
- 2M23 E8
- 2M24 F7
- 2M25 A9
- 2M26 A10
- 2M27 A10
- 2M28 A10
- 2M29 A11
- 2M30 A11
- 2M31 E5
- 2M32 A9
- 2M33 F3
- 2M56 E7
- 2M65 A2
- 2M66 A2
- 2M67 B2
- 2M68 B2
- 3M00 A4
- 3M01-1 B7
- 3M01-2 B7
- 3M01-3 B7
- 3M01-4 B7
- 3M02-1 B7
- 3M02-2 B7
- 3M02-3 B7
- 3M02-4 B7
- 3M03-1 B7
- 3M03-2 B7
- 3M03-3 B7
- 3M03-4 B7
- 3M04-1 C7
- 3M04-2 C7
- 3M04-3 B7
- 3M04-4 B7
- 3M06-1 C7
- 3M06-2 C7
- 3M06-3 C7
- 3M06-4 C7
- 3M07-1 D7
- 3M07-2 D7
- 3M07-3 D7
- 3M07-4 D7
- 3M08-1 D7
- 3M08-2 D7
- 3M08-3 D7
- 3M08-4 D7
- 3M09-1 E7
- 3M09-2 E7
- 3M09-3 E7
- 3M10 F3
- 3M11 F3
- 3M12 E4
- 3M13 E5
- 3M14 G7
- 3M15 G7
- 3M16 C9
- 3M28 C7
- 3M29 D7
- 3M50 G3
- 3M51 G3
- 3M52 G3
- 3M53 G2
- 3M54 G2
- 3M55 G2
- 3M56 G2
- 3M57 G2
- 3M58 G2
- 3M59 G2
- 3M78 F7
- 3M79 A5
- 3M86 A6
- 3M87 A5
- 3M88 C8
- 3M89 C5
- 3M90 E4
- 4M00 A5
- 4M01 B5
- 4M02 B5
- 4M03 B5
- 4M04 F3
- 4M05 F3
- 4M06 F3
- 4M08 F7
- 4M09 F7
- 4M10 D10
- 4M16 F3
- 4M17 F3
- 5M00 E8
- 5M01 F7
- 5M02 E2
- 5M03 A2
- 5M04 A2
- 5M05 A10
- 7M00-1 A6
- 7M00-2 F4
- 7M01 B11
- 7M03 E8
- 7M17 A4
- FM01 G2
- FM02 G2
- FM03 G2
- FM04 G2
- FM05 G2
- IM00 C8
- IM01 E7
- IM02 C7
- IM03 C5
- IM04 C5
- IM05 D7
- IM06 C5
- IM07 C5
- IM08 A10
- IM09 E8
- IM10 C7
- IM11 F7
- IM12 C10
- IM13 E2
- IM15 E2
- IM16 F3
- IM17 F3
- IM18 F3
- IM20 G6

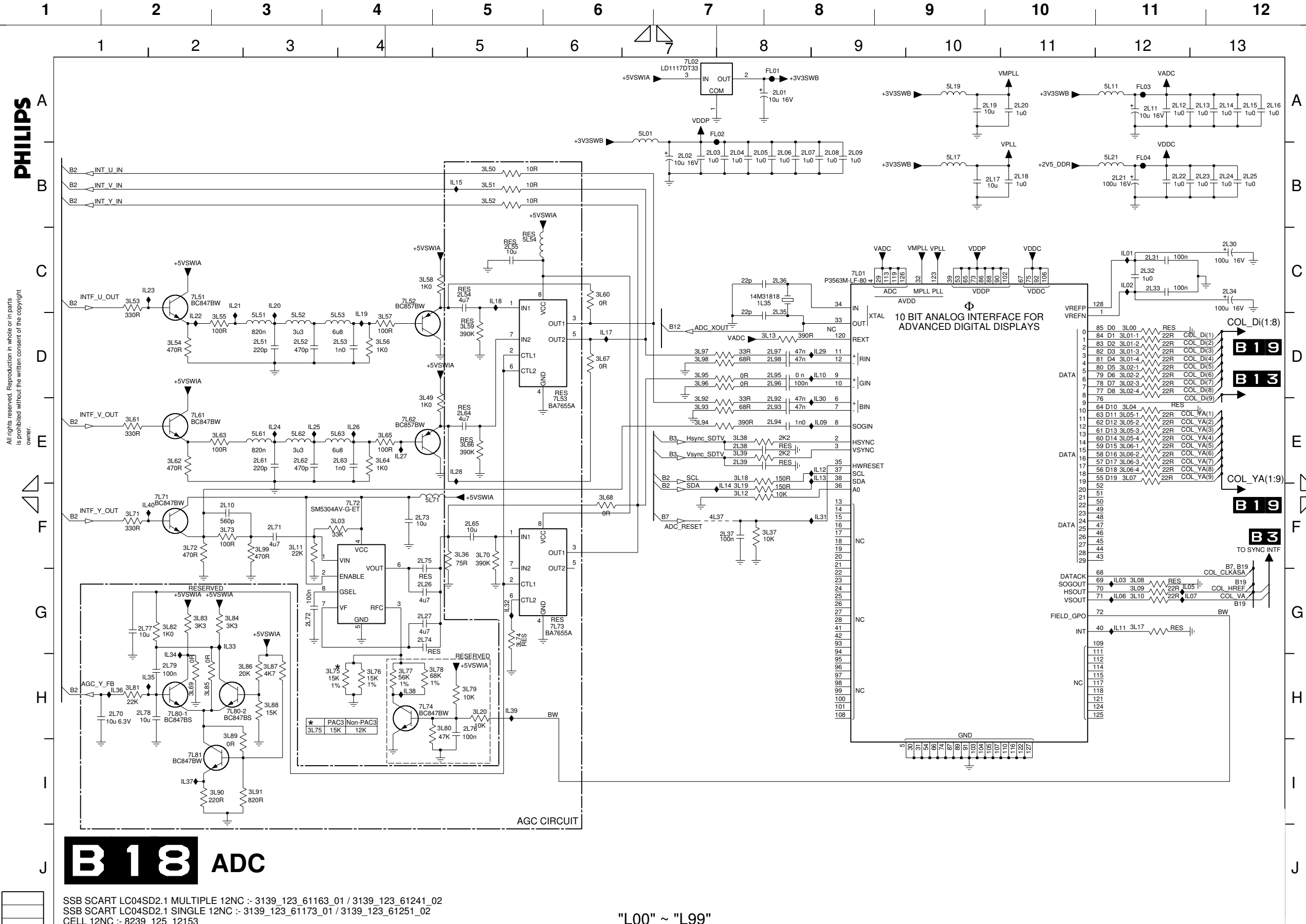

B 18 ADC

SSB SCART LC04SD2.1 MULTIPLE 12NC :- 3139_123_61163_01 / 3139_123_61241_02
 SSB SCART LC04SD2.1 SINGLE 12NC :- 3139_123_61173_01 / 3139_123_61251_02
 CELL 12NC :- 8239_125_12153

"L00" ~ "L99"

- | | | |
|------------|-----------|---------|
| 1L35 C8 | 3L51 B5 | 1L24 D3 |
| 2L01 A8 | 3L52 B5 | 1L25 D3 |
| 2L02 A7 | 3L53 C2 | 1L26 D4 |
| 2L03 A7 | 3L54 C2 | 1L27 D4 |
| 2L04 A7 | 3L55 C3 | 1L28 D5 |
| 2L05 A7 | 3L56 C4 | 1L29 C8 |
| 2L06 A8 | 3L57 C4 | 1L30 D8 |
| 2L07 A8 | 3L58 C4 | 1L31 E8 |
| 2L08 A8 | 3L59 C5 | 1L32 F5 |
| 2L09 A8 | 3L60 C6 | 1L33 F3 |
| 2L10 E3 | 3L61 D2 | 1L34 F2 |
| 2L11 A11 | 3L62 D2 | 1L35 F2 |
| 2L12 A11 | 3L63 D3 | 1L36 F2 |
| 2L13 A11 | 3L64 D4 | 1L37 G2 |
| 2L14 A12 | 3L65 D4 | 1L38 F4 |
| 2L15 A12 | 3L66 D5 | 1L39 F5 |
| 2L16 A12 | 3L67 C6 | 1L40 E2 |
| 2L17 B10 | 3L68 E6 | |
| 2L18 B10 | 3L69 F2 | |
| 2L19 A10 | 3L70 E5 | |
| 2L20 A10 | 3L71 E2 | |
| 2L21 B11 | 3L72 E2 | |
| 2L22 B11 | 3L73 E3 | |
| 2L23 B11 | 3L74 F5 | |
| 2L24 B12 | 3L75 F4 | |
| 2L25 B12 | 3L76 F4 | |
| 2L26 E4 | 3L77 F4 | |
| 2L27 F4 | 3L78 F5 | |
| 2L30 B12 | 3L79 F5 | |
| 2L31 B11 | 3L80 G5 | |
| 2L32 B11 | 3L81 F2 | |
| 2L33 C11 | 3L82 F2 | |
| 2L34 C12 | 3L83 F2 | |
| 2L35 C8 | 3L84 F3 | |
| 2L36 C8 | 3L85 F2 | |
| 2L37 E7 | 3L86 F3 | |
| 2L38 D7 | 3L87 F3 | |
| 2L39 D7 | 3L88 F3 | |
| 2L51 C3 | 3L89 G3 | |
| 2L52 C3 | 3L90 G3 | |
| 2L53 C4 | 3L91 G3 | |
| 2L54 C5 | 3L92 D7 | |
| 2L55 B5 | 3L93 D7 | |
| 2L61 D3 | 3L94 D7 | |
| 2L62 D3 | 3L95 C7 | |
| 2L63 D4 | 3L96 D7 | |
| 2L64 D5 | 3L97 C7 | |
| 2L65 E5 | 3L98 C7 | |
| 2L70 F2 | 3L99 E3 | |
| 2L71 E3 | 4L37 E7 | |
| 2L72 F3 | 5L01 A6 | |
| 2L73 E4 | 5L11 A11 | |
| 2L74 F4 | 5L17 A9 | |
| 2L75 E4 | 5L19 A9 | |
| 2L76 G5 | 5L21 A11 | |
| 2L77 F2 | 5L51 C3 | |
| 2L78 F2 | 5L53 C4 | |
| 2L92 D8 | 5L54 B5 | |
| 2L93 D8 | 5L61 D3 | |
| 2L94 D8 | 5L62 D3 | |
| 2L95 C8 | 5L63 D4 | |
| 2L96 D8 | 5L71 E5 | |
| 2L97 C8 | 7L01 C8 | |
| 2L98 C8 | 7L02 A7 | |
| 3L00 C11 | 7L51 C2 | |
| 3L01-1 C11 | 7L52 C4 | |
| 3L01-2 C11 | 7L53 D6 | |
| 3L01-3 C11 | 7L61 D2 | |
| 3L01-4 C11 | 7L62 D4 | |
| 3L02-1 C11 | 7L71 E2 | |
| 3L02-2 C11 | 7L72 E4 | |
| 3L02-3 D11 | 7L73 F6 | |
| 3L02-4 D11 | 7L74 F4 | |
| 3L03 E4 | 7L80-1 G2 | |
| 3L04 D11 | 7L80-2 F3 | |
| 3L05-1 D11 | 7L81 G2 | |
| 3L05-2 D11 | FL01 A8 | |
| 3L05-3 D11 | FL02 A7 | |
| 3L05-4 D11 | FL03 A11 | |
| 3L06-1 D11 | FL04 A11 | |
| 3L06-2 D11 | IL01 B11 | |
| 3L06-3 D11 | IL02 C11 | |
| 3L06-4 D11 | IL03 E11 | |
| 3L07 D11 | IL05 E11 | |
| 3L08 E11 | IL06 E11 | |
| 3L09 E11 | IL07 E11 | |
| 3L10 E11 | IL09 D8 | |
| 3L11 E3 | IL10 C8 | |
| 3L12 E7 | IL11 F11 | |
| 3L13 C8 | IL12 D8 | |
| 3L17 F11 | IL13 D8 | |
| 3L18 D7 | IL14 D7 | |
| 3L19 D7 | IL15 B5 | |
| 3L20 F5 | IL17 C6 | |
| 3L36 E5 | IL18 C5 | |
| 3L37 E8 | IL19 C4 | |
| 3L38 D7 | IL20 C3 | |
| 3L39 D7 | IL21 C3 | |
| 3L49 D4 | IL22 C2 | |
| 3L50 B5 | IL23 C2 | |

All rights reserved. Reproduction in whole or in parts is prohibited without the written consent of the copyright owner.

PHILIPS

1 2 3 4 5 6 7 8 9 10 11 12 13

1K00 A10 1K04 C1 2K02 B3 2K05 B3 2K08 C4 2K12 C4 2K15 E3 2K18 C10 2K21 B8 2K24 B8 2K27 B9 3K01 B3 3K05 C3 3K08 D3 3K12 B8 4K02 E2 4K05 A9 5K00 A8 FK00 C1 FK03 D1 FK06 D1 FK09 C10 IK00 A10 IK03 B10 IK16 A9
1K01 C1 2K00 B9 2K03 B3 2K06 C3 2K10 D3 2K13 D3 2K16 E3 2K19 C3 2K22 B8 2K25 B9 2K28 B9 3K02 C3 3K06 D4 3K09 E3 3K11 A8 4K03 A9 4K06 A10 5K01 C3 FK01 C1 FK04 D1 FK07 D1 FK10 D1 IK01 A10 IK04 B3 IK17 C3
1K02 C10 2K01 B8 2K04 B3 2K07 C3 2K11 D3 2K14 D3 2K17 E3 2K20 C3 2K23 B8 2K26 B9 3K00 B3 3K03 C4 3K07 D3 3K11 A8 4K01 A9 4K04 A9 4K07 A9 5K02 A8 FK02 D1 FK05 D1 FK08 C10 FK11 B10 IK02 A10 IK05 A10 IK18 D3

1 2 3 4 5 6 7 8 9 10

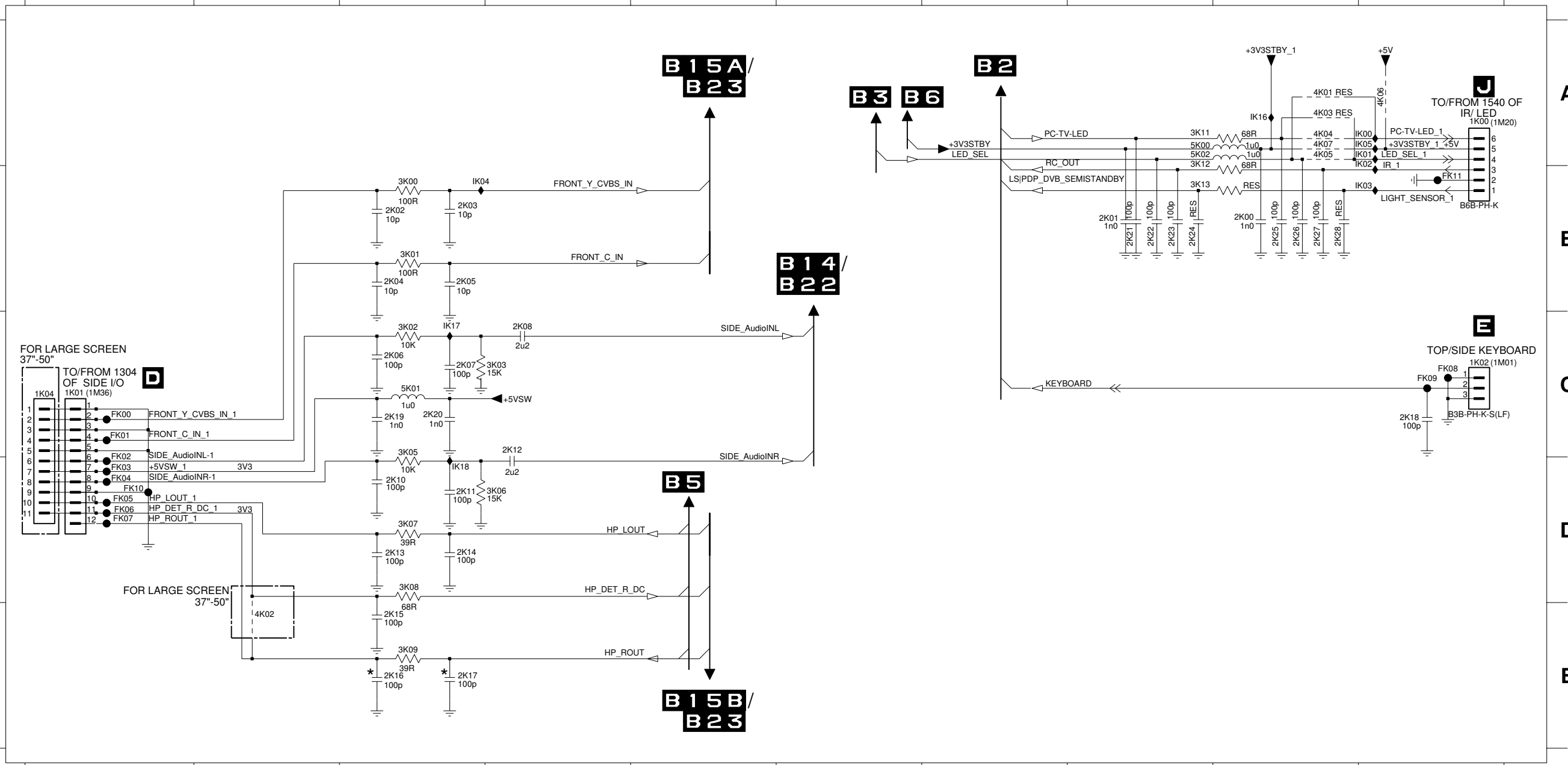

1 2 3 4 5 6 7 8 9 10

B 17 SIDE CONNECTORS

SSB SCART LC04SD2.1 MULTIPLE 12NC :- 3139_123_61163_01 / 3139_123_61241_02
 SSB SCART LC04SD2.1 SINGLE 12NC :- 3139_123_61173_01 / 3139_123_61251_02
 CELL 12NC :- 8239_125_12143

"K00" ~ "K99"

1 2 3 4 5 6 7 8 9 10 11 12 13

1 2 3 4 5 6 7 8 9 10 11 12 13

A B C D E F G H I J

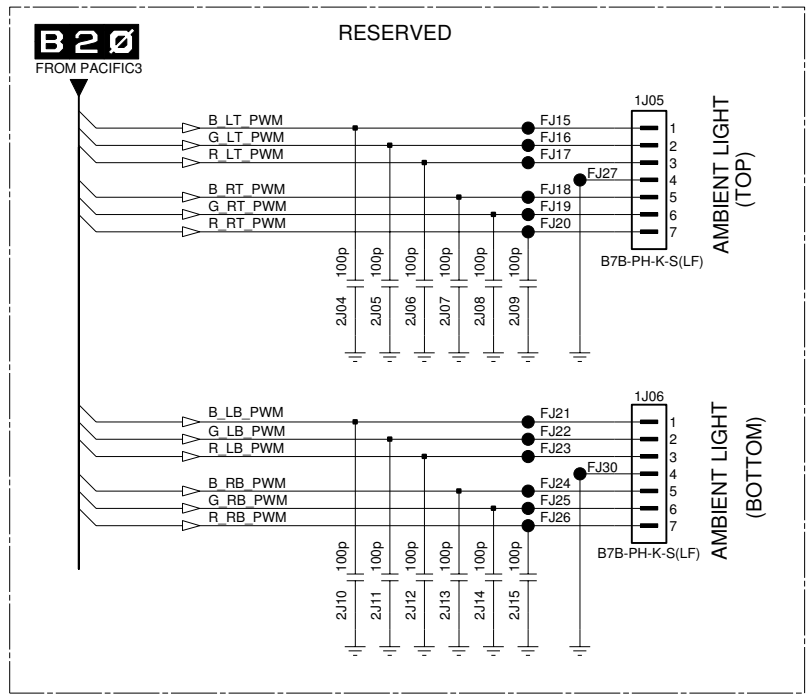
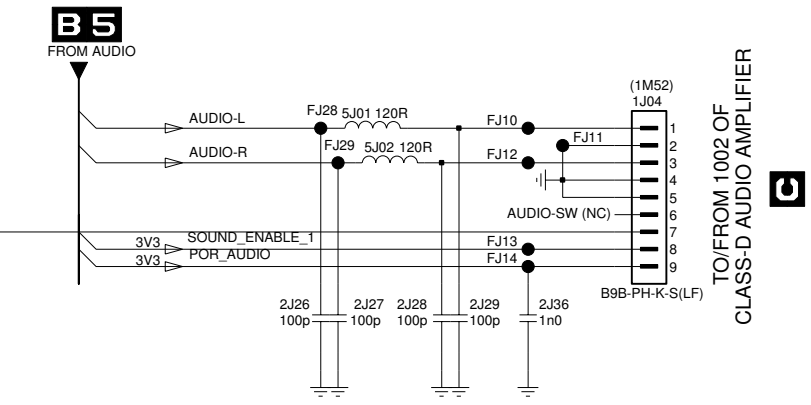
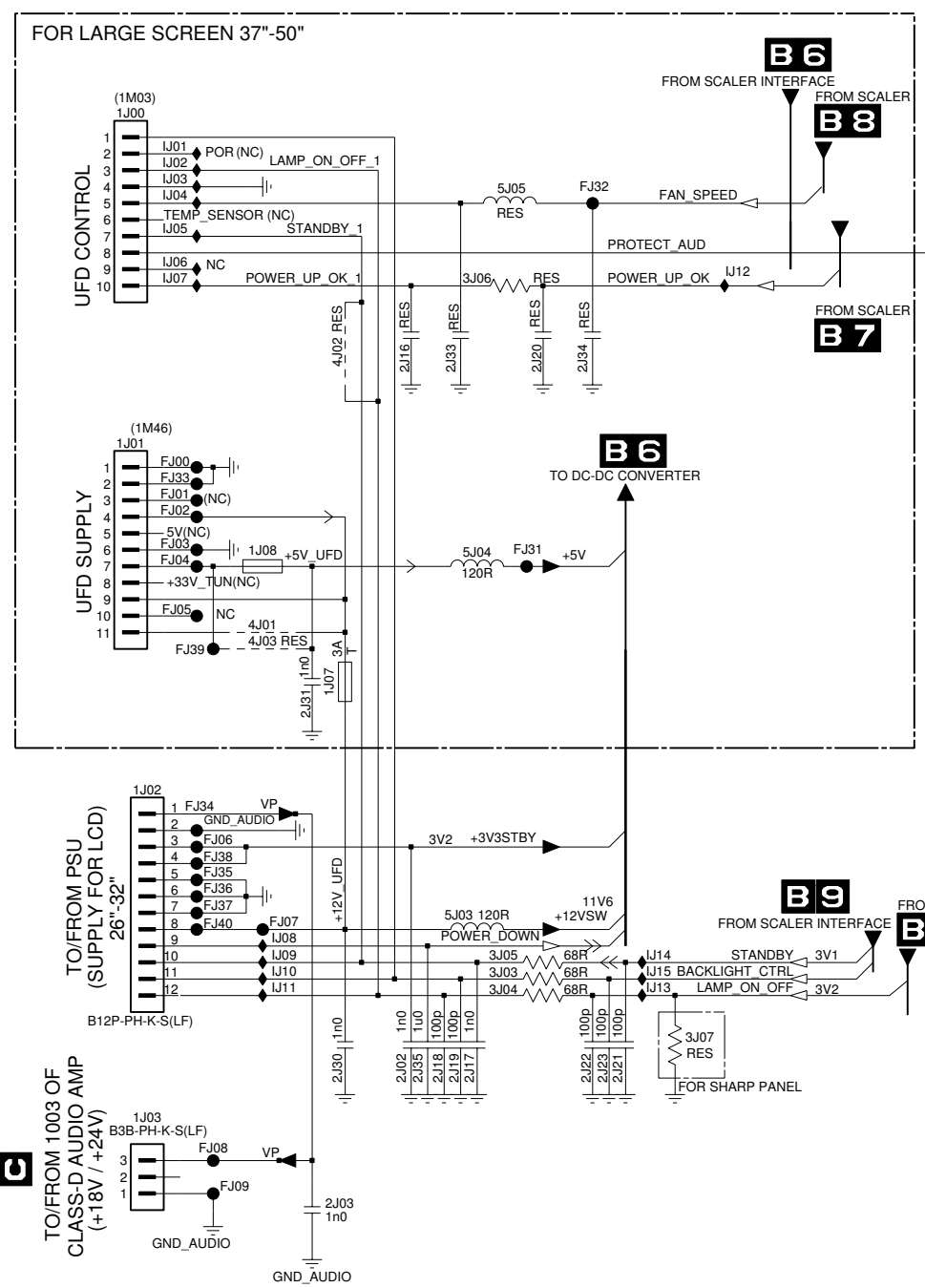

- J00 A1
- J01 B1
- J02 D1
- J03 E1
- J04 A8
- J05 C8
- J06 D8
- J07 C2
- J08 C2
- J09 E2
- J10 E2
- J11 E2
- J12 E2
- J13 E2
- J14 E2
- J15 E2
- J16 C7
- J17 C7
- J18 C7
- J19 C7
- J20 C7
- J21 D7
- J22 D7
- J23 D7
- J24 D7
- J25 E7
- J26 E7
- J27 C8
- J28 A6
- J29 A6
- J30 D8
- J31 C3
- J32 A3
- J33 B1
- J34 D1
- J35 D1
- J36 D1
- J37 D1
- J38 D1
- J39 C1
- J40 D1
- J01 A1
- J02 A1
- J03 A1
- J04 A1
- J05 A1
- J06 A1
- J07 B1
- J08 D2
- J09 D2
- J10 E2
- J11 E2
- J12 A4
- J13 E3
- J14 D3
- J15 E3

B 16 TOP CONNECTORS

SSB SCART LC04SD2.1 MULTIPLE 12NC :- 3139_123_61163_01 / 3139_123_61241_02
 SSB SCART LC04SD2.1 SINGLE 12NC :- 3139_123_61173_01 / 3139_123_61251_02
 CELL 12NC :- 8239_125_12133

"J00" ~ "J99"

1 2 3 4 5 6 7 8 9 10 11 12 13

All rights reserved. Reproduction in whole or in parts is prohibited without the written consent of the copyright owner.

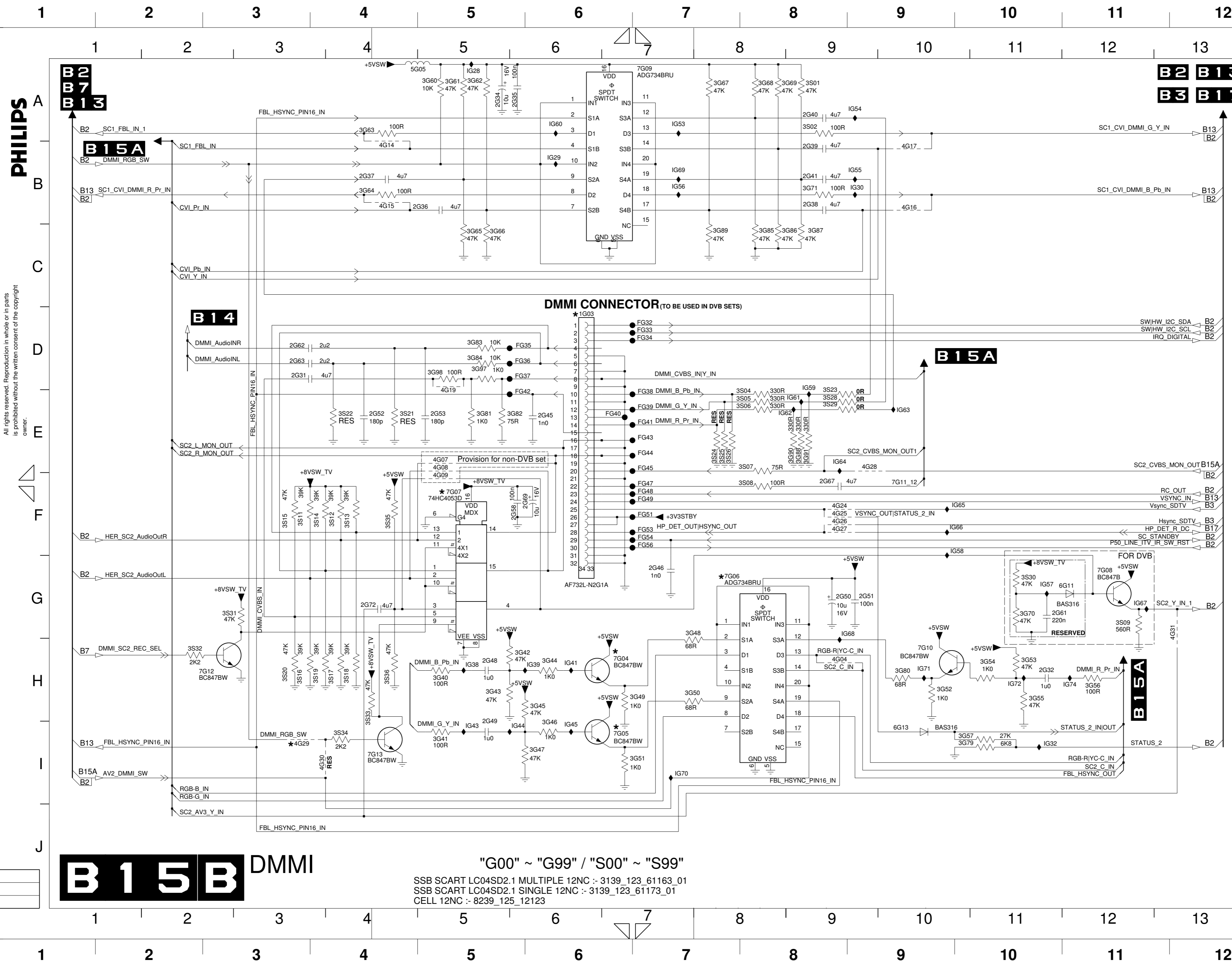

PHILIPS

B15B DMMI

"G00" ~ "G99" / "S00" ~ "S99"
SSB SCART LC04SD2.1 MULTIPLE 12NC :- 3139_123_61163_01
SSB SCART LC04SD2.1 SINGLE 12NC :- 3139_123_61173_01
CELL 12NC :- 8239_125_12123

- 1G03 C6
- 2G31 D3
- 2G32 F10
- 2G34 A5
- 2G35 A5
- 2G36 B4
- 2G37 B4
- 2G38 B8
- 2G39 A8
- 2G40 A8
- 2G41 B8
- 2G45 D6
- 2G46 E7
- 2G48 F5
- 2G49 G5
- 2G50 F9
- 2G51 F9
- 2G52 D4
- 2G53 D5
- 2G58 E5
- 2G61 F10
- 2G62 C3
- 2G63 C3
- 2G67 E8
- 2G69 E6
- 2G72 F4
- 3G40 F5
- 3G41 G5
- 3G42 F5
- 3G43 F5
- 3G44 F6
- 3G45 G6
- 3G46 G6
- 3G47 G6
- 3G48 F7
- 3G49 G6
- 3G50 F7
- 3G51 G6
- 3G52 F9
- 3G53 F10
- 3G54 F10
- 3G55 G10
- 3G56 F11
- 3G57 G10
- 3G60 A5
- 3G61 A5
- 3G62 A5
- 3G63 A4
- 3G64 B4
- 3G65 B5
- 3G66 B5
- 3G67 A7
- 3G68 A8
- 3G69 A8
- 3G70 F10
- 3G71 B8
- 3G79 G10
- 3G80 F9
- 3G81 D5
- 3G82 D5
- 3G83 C5
- 3G84 C5
- 3G85 B8
- 3G86 B8
- 3G87 B8
- 3G88 D8
- 3G89 B7
- 3G90 D8
- 3G91 D8
- 3G92 C5
- 3G98 C5
- 3S01 A8
- 3S02 A8
- 3S04 D8
- 3S05 D8
- 3S06 D8
- 3S07 D8
- 3S08 E8
- 3S09 F11
- 3S11 E3
- 3S12 E4
- 3S13 E4
- 3S14 E4
- 3S15 E3
- 3S16 F3
- 3S17 F4
- 3S18 F4
- 3S19 F4
- 3S20 F3
- 3S21 D4
- 3S22 D4
- 3S23 D8
- 3S24 D7
- 3S25 D7
- 3S26 D7
- 3S28 D8
- 3S29 D8
- 3S30 F3
- 3S31 F3
- 3S32 F2
- 3S33 G4
- 3S34 G4
- 3S35 E4
- 3S36 F4
- 4G04 F8
- 4G07 D5
- 4G08 D5
- 4G09 D5
- 4G14 A4
- 4G15 B4
- 4G16 B9
- 4G17 A9
- 4G19 D5
- 4G24 E8
- 4G25 E8
- 4G26 E8
- 4G27 E8
- 4G28 D9
- 4G29 G3
- 4G30 G4
- 4G31 F12
- 5G05 A4
- 6G11 E10
- 6G13 G9
- 7G04 F6
- 7G05 G6
- 7G06 E7
- 7G07 E5
- 7G08 E11
- 7G09 A7
- 7G10 F9
- 7G12 F2
- 7G13 G4
- FG32 C7
- FG33 C7
- FG34 C7
- FG35 C5
- FG36 C5
- FG37 D5
- FG38 D7
- FG39 D7
- FG40 D6
- FG41 D7
- FG42 D5
- FG43 D7
- FG44 D7
- FG45 D7
- FG47 E7
- FG48 E7
- FG49 E7
- FG51 E7
- FG53 E7
- FG54 E7
- FG56 E7
- IG28 A5
- IG29 A6
- IG30 B9
- IG32 G10
- IG38 F5
- IG39 F6
- IG41 F6
- IG43 G5
- IG44 G5
- IG45 G6
- IG53 A7
- IG54 A9
- IG55 B9
- IG56 B7
- IG57 E10
- IG58 E10
- IG59 D8
- IG60 A6
- IG61 D8
- IG62 D8
- IG63 D9
- IG64 D8
- IG65 E10
- IG66 E10
- IG67 F11
- IG68 F9
- IG69 B7
- IG70 G7
- IG71 F9
- IG72 F10
- IG74 F11

PHILIPS

All rights reserved. Reproduction in whole or in parts is prohibited without the written consent of the copyright owner.

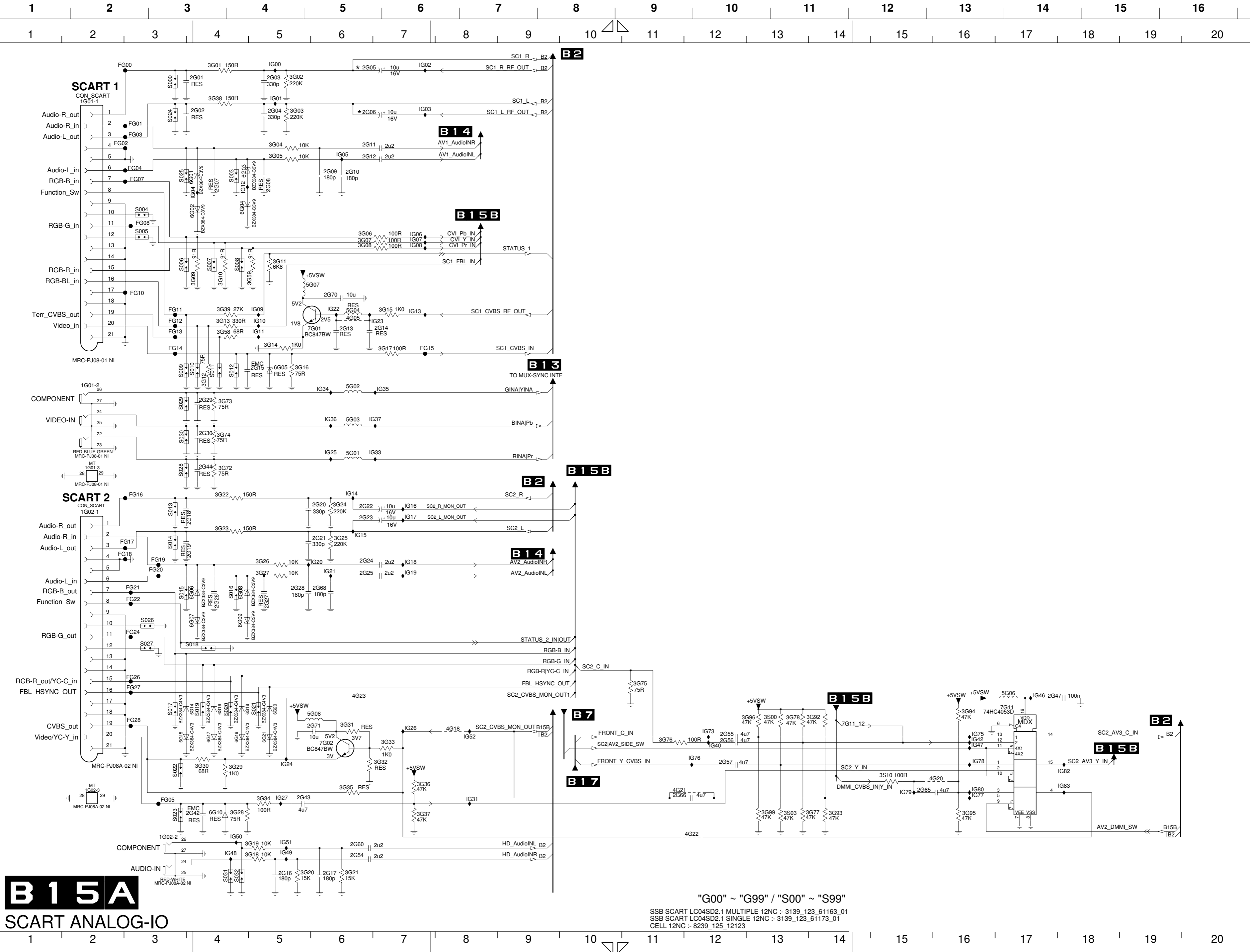

B15A
SCART ANALOG-IO

"G00" ~ "G99" / "S00" ~ "S99"

SSB SCART LC04SD2.1 MULTIPLE 12NC : 3139_123_61163_01
SSB SCART LC04SD2.1 SINGLE 12NC : 3139_123_61173_01
CELL 12NC : 8239_125_12123

1G01-1 B2	FG01 B2
1G01-2 E2	FG02 B2
1G01-3 F2	FG03 B2
1G02-1 G2	FG04 B2
1G02-2 K3	FG05 K3
1G02-3 J2	FG07 C2
2G01 A3	FG08 C2
2G02 B3	FG10 D2
2G03 A4	FG11 D3
2G04 B4	FG12 D3
2G05 A5	FG13 E3
2G06 B5	FG14 E3
2G07 C3	FG15 E6
2G08 C4	FG16 G2
2G09 B5	FG17 G2
2G10 B5	FG18 G2
2G11 B5	FG19 G3
2G12 B5	FG20 H3
2G13 D5	FG21 H2
2G14 D5	FG22 H2
2G15 E4	FG24 H2
2G16 K4	FG26 I2
2G17 K5	FG27 I2
2G18 G3	FG28 J2
2G19 G3	IG00 A4
2G20 G5	IG01 B4
2G21 G5	IG02 A6
2G22 G5	IG03 B6
2G23 G5	IG04 C3
2G24 G5	IG05 B5
2G25 H5	IG06 C5
2G26 H3	IG07 C6
2G27 H4	IG08 C6
2G28 H5	IG09 D4
2G29 E3	IG10 D4
2G30 F3	IG11 E4
2G42 K3	IG12 C4
2G43 K4	IG13 D6
2G44 F3	IG14 G5
2G47 I14	IG15 G5
2G54 K5	IG16 G6
2G55 J10	IG17 G6
2G56 J10	IG18 G6
2G57 J10	IG19 H6
2G60 K5	IG20 G5
2G65 J12	IG21 H5
2G66 J9	IG22 D5
2G68 H5	IG23 D5
2G70 D5	IG24 J4
2G71 J5	IG25 F5
3G01 A3	IG26 J6
3G02 A4	IG27 K4
3G03 B4	IG31 K7
3G04 B4	IG33 F5
3G05 B4	IG34 E5
3G06 C5	IG35 E6
3G07 C5	IG36 F5
3G08 C5	IG37 F5
3G09 D3	IG40 J10
3G10 D3	IG42 J13
3G11 D4	IG46 I14
3G12 E3	IG47 J13
3G13 D3	IG48 K4
3G14 E4	IG49 K4
3G15 D5	IG50 K4
3G16 E4	IG51 K4
3G17 E5	IG52 J7
3G18 K4	IG73 J10
3G19 K4	IG75 J13
3G20 K4	IG76 J9
3G21 K5	IG77 J13
3G22 G3	IG78 J13
3G23 G3	IG79 J12
3G24 G5	IG80 J13
3G25 G5	IG82 J14
3G26 G4	IG83 J14
3G27 H4	S000 A3
3G28 K4	S003 C4
3G29 J4	S004 C2
3G30 J3	S005 C2
3G31 J5	S006 D3
3G32 J5	S007 D3
3G33 J5	S008 D4
3G34 K4	S009 E3
3G35 J5	S010 E3
3G36 J6	S011 E3
3G37 K6	S012 E4
3G38 B3	S013 G3
3G39 D3	S014 G3
3G58 E3	S015 H3
3G59 D4	S016 H4
3G72 F3	S017 I3
3G73 E3	S018 I3
3G74 F3	S019 I3
3G75 I9	S020 I4
3G76 J9	S021 I4
3G77 K11	S022 J3
3G78 I11	S023 K3
3G92 I11	S024 B3
3G93 K11	S025 C3
3G94 I13	S026 H2
3G95 K13	S027 I2
3G96 I10	S028 F3
3G99 K11	S029 F3
3S00 I10	S030 F3
3S03 K11	S031 L4
3S10 J12	S032 L4
4G05 D5	
4G18 J6	
4G20 J13	
4G21 J9	
4G22 K9	
4G23 I5	
5G01 F5	
5G02 E5	
5G03 F5	
5G04 D5	
5G06 I14	
5G07 D5	
5G08 I5	
6G01 C3	
6G02 C3	
6G03 B4	
6G04 C4	
6G05 E4	
6G06 H3	
6G07 H3	
6G08 H4	
6G09 H4	
6G10 K3	
6G14 I3	
6G15 J3	
6G16 I3	
6G17 J3	
6G18 I4	
6G19 J4	
6G20 I4	
6G21 J4	
7G01 D5	
7G02 J5	
7G11 I14	
FG00 A2	

1 2 3 4 5 6 7 8 9 10 11 12 13

1F01 A5	2F02 C9	2F14 A7	3F02 B2	3F06 B6	3F10 B7	3F14 D6	3F18 D7	3F25 A6	3F29 B3	7F02 D1	FF01 A1	FF05 A1	FF09 A1	FF13 B1	FF17 C1	FF21 C1	FF25 D1	IF03 A7	IF08 C6	IF13 C8	IF18 D2
1F02 A1	2F03 C8	2F15 A7	3F03 D2	3F07 B6	3F11 B7	3F15 D6	3F19 D7	3F26 A7	3F30 D2	7F03 C8	FF02 A1	FF06 A1	FF10 B1	FF14 C1	FF18 C1	FF22 D1	FF26 D1	IF04 A7	IF09 C6	IF14 C8	S001 A6
1F03 C1	2F04 D8	2F16 A7	3F04 D2	3F08 B6	3F12 B7	3F16 D6	3F20 D7	3F27 A7	3F31 D3	7F04 C3	FF03 A1	FF07 A1	FF11 B1	FF15 C1	FF19 C1	FF23 D1	IF01 A5	IF05 C6	IF10 D6	IF16 B2	S002 A6
2F01 C8	2F13 A7	3F01 B2	3F05 B6	3F09 B7	3F13 D6	3F17 D7	3F24 A6	3F28 B2	7F01 B1	7F05 D3	FF04 A1	FF08 A1	FF12 B1	FF16 C1	FF20 C1	FF24 D1	IF02 A5	IF06 C6	IF12 D6	IF17 B2	

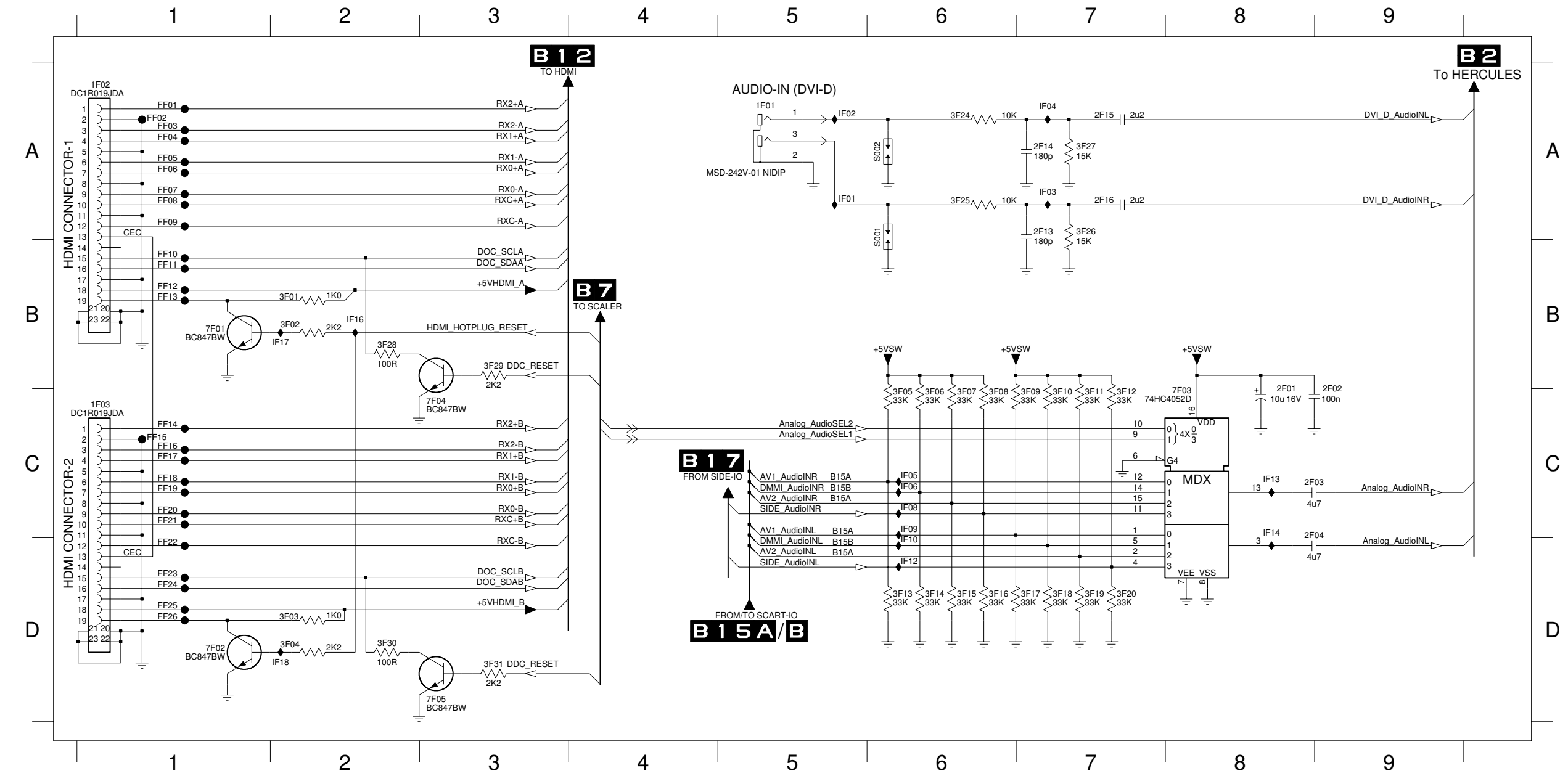

B 1 4 DIGITAL IO

SSB SCART LC04SD2.1 MULTIPLE 12NC :- 3139_123_61163_01
 SSB SCART LC04SD2.1 SINGLE 12NC :- 3139_123_61173_01
 CELL 12NC :- 8239_125_12123

"F00" ~ "F99"

1 2 3 4 5 6 7 8 9 10 11 12 13

PHILIPS

All rights reserved. Reproduction in whole or in parts is prohibited without the written consent of the copyright owner.

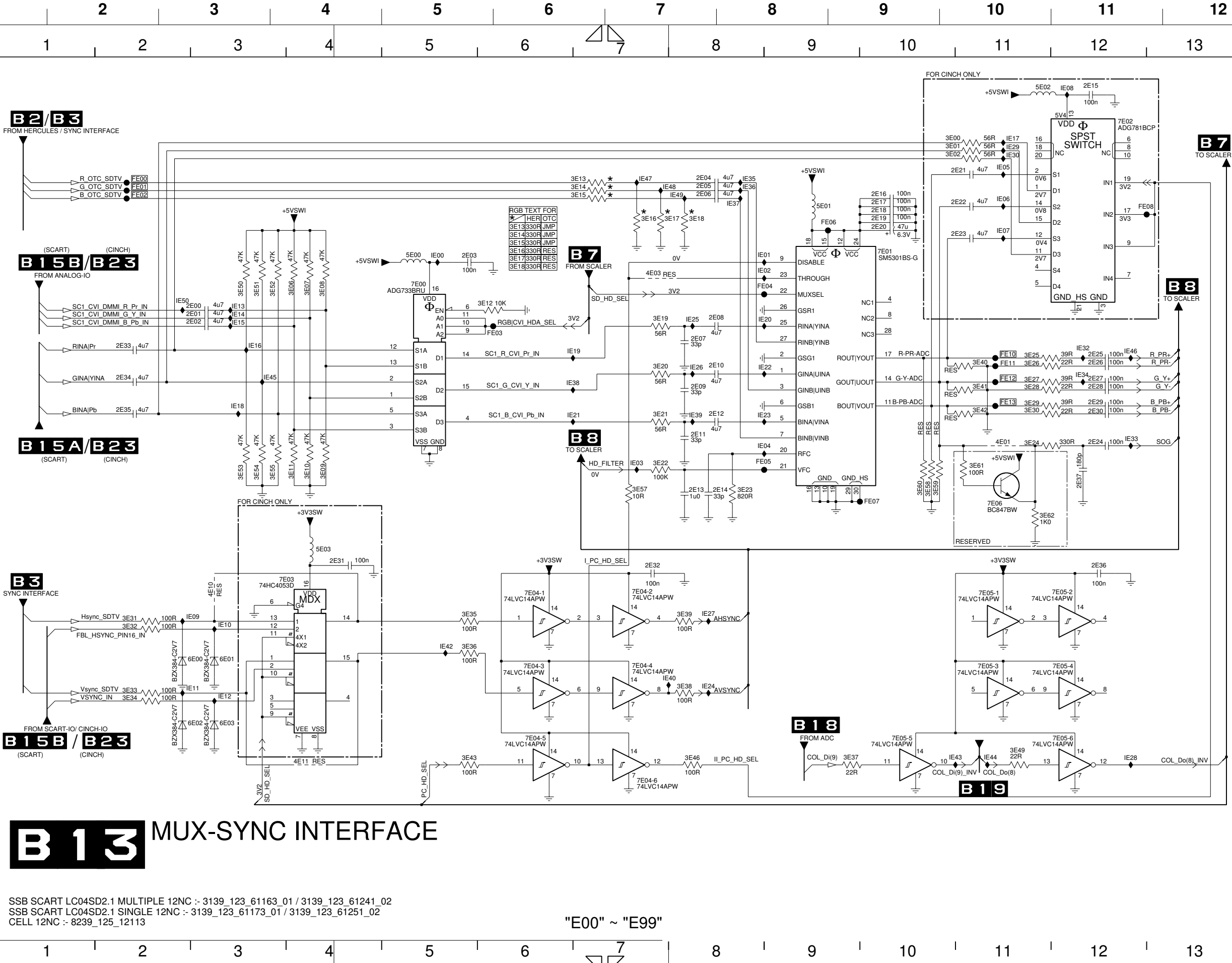

B13 MUX-SYNC INTERFACE

SSB SCART LC04SD2.1 MULTIPLE 12NC :- 3139_123_61163_01 / 3139_123_61241_02
 SSB SCART LC04SD2.1 SINGLE 12NC :- 3139_123_61173_01 / 3139_123_61251_02
 CELL 12NC :- 8239_125_12113

"E00" ~ "E99"

- 2E00 C3
- 2E01 C3
- 2E02 C3
- 2E03 B5
- 2E04 B7
- 2E05 B7
- 2E06 B7
- 2E07 C7
- 2E08 C8
- 2E09 D7
- 2E10 C8
- 2E11 D7
- 2E12 D8
- 2E13 D7
- 2E14 D8
- 2E15 A11
- 2E16 B9
- 2E17 B9
- 2E18 B9
- 2E19 B9
- 2E20 B9
- 2E21 B10
- 2E22 B10
- 2E23 B10
- 2E24 D11
- 2E25 C11
- 2E26 C11
- 2E27 C11
- 2E28 D11
- 2E29 D11
- 2E30 D11
- 2E31 E4
- 2E32 E7
- 2E33 C2
- 2E34 C2
- 2E35 D2
- 2E36 E11
- 2E37 D11
- 3E00 A10
- 3E01 A10
- 3E02 A10
- 3E06 C4
- 3E07 C4
- 3E08 C4
- 3E09 D4
- 3E10 D4
- 3E11 D4
- 3E12 C5
- 3E13 B6
- 3E14 B6
- 3E15 B6
- 3E16 B7
- 3E17 B7
- 3E18 B7
- 3E19 C7
- 3E20 C7
- 3E21 D7
- 3E22 D7
- 3E23 D8
- 3E24 D10
- 3E25 C10
- 3E26 C10
- 3E27 C10
- 3E28 D10
- 3E29 D10
- 3E30 D10
- 3E31 F2
- 3E32 F2
- 3E33 F2
- 3E34 F2
- 3E35 F5
- 3E36 F5
- 3E37 G9
- 3E38 F7
- 3E39 F7
- 3E40 C10
- 3E41 D10
- 3E42 D10
- 3E43 G5
- 3E46 G7
- 3E49 G10
- 3E50 C3
- 3E51 C3
- 3E52 C4
- 3E53 D3
- 3E54 D3
- 3E55 D4
- 3E57 D7
- 3E58 D9
- 3E59 D9
- 3E60 D9
- 3E61 D10
- 3E62 E10
- 4E01 D10
- 4E03 B7
- 4E10 E3
- 4E11 G4
- 5E00 B5
- 5E01 B8
- 5E02 A10
- 5E03 E4
- 6E00 F3
- 6E01 F3
- 6E02 G3
- 6E03 G3
- 7E00 C5
- 7E01 B9
- 7E02 A11
- 7E03 E4
- 7E04-1 E6
- 7E04-2 E7
- 7E04-3 F6
- 7E04-4 F7
- 7E04-5 G6
- 7E04-6 G7
- 7E05-1 E10
- 7E05-2 E11
- 7E05-3 F10
- 7E05-4 F11
- 7E05-5 G9
- 7E05-6 G11
- 7E06 E10
- 7E07 B2
- 7E08 B2
- 7E09 B2
- 7E10 C10
- 7E11 C10
- 7E12 C10
- 7E13 D10
- IE00 B5
- IE01 B8
- IE02 B8
- IE03 D7
- IE04 D8
- IE05 B10
- IE06 B10
- IE07 B10
- IE08 A11
- IE09 F3
- IE10 F3
- IE11 F3
- IE12 F3
- IE13 C3
- IE14 C3
- IE15 C3
- IE16 C3
- IE17 A10
- IE18 D3
- IE19 C6
- IE20 C8
- IE21 D6
- IE22 C8
- IE23 D8
- IE24 F7
- IE25 C7
- IE26 C7
- IE27 F7
- IE28 G11
- IE29 A10
- IE30 A10
- IE31 C11
- IE32 C11
- IE33 D11
- IE34 C11
- IE35 B8
- IE36 B8
- IE37 B8
- IE38 C6
- IE39 D7
- IE40 F7
- IE41 F5
- IE42 G5
- IE43 G10
- IE44 G10
- IE45 C4
- IE46 C11
- IE47 B7
- IE48 B7
- IE49 B7
- IE50 C3

1 2 3 4 5 6 7 8 9 10 11 12 13 14 15 16 17 18 19 20

A 2D00 A10 2D10 B2 2D15 B2 2D22 E2 2D30 D1 2D36 E2 2D43 G2 2D48 I2 2D53 G10 2D58 H11 3D03 B10 3D09 A10 3D15-3 C14 3D16-4 C14 3D18 F10 3D20-4 G8 3D22 E14 4D02 G8 5D00 G1 5D05 H2 7D03-1 A11 7D03-2 G6 7D03-3 A4 7D03-3 G6 FD01 B9 FD02 B9 FD06 E15 FD11 I2 FD17 A9 ID10 G10 ID18 H14 ID25 I4 ID28 G8
2D01 B10 2D11 B2 2D17 B2 2D23 E2 2D31 D1 2D37 E2 2D44 G2 2D49 H4 2D59 I11 3D05 I4 3D10 B10 3D15-4 C14 3D17-1 B14 3D19 F9 3D21-1 B14 3D23 D14 4D03 H8 5D01 G1 5D06 F1 7D03-2 G6 7D03-3 A4 7D03-3 G6 FD02 B9 FD06 E15 FD11 F1 FD17 A9 ID11 H11 ID19 I14 ID20 A9 ID22 A9 ID24 I5
2D02 F2 2D12 B1 2D17 B2 2D24 E2 2D32 E1 2D38 E2 2D45 H1 2D50 G9 3D00 A9 3D06 I4 3D11 E13 3D15-1 C14 3D16-1 D14 3D17-2 B14 3D20-1 G8 3D21-2 B14 3D24 H11 4D04 I4 5D02 G1 5D05 H2 7D03-3 A4 7D03-3 G6 FD03 C9 FD08 G1 FD09 G1 FD10 I2 FD13 G9 ID00 H1 ID01 H2 ID08 H10 ID09 H11 ID10 G10 ID11 H11 ID13 E15 ID20 A9 ID22 A9 ID24 I5
2D08 B1 2D13 B1 2D18 B2 2D25 E2 2D34 E2 2D39 E2 2D46 H2 2D51 G9 2D56 H10 3D01 A10 3D07 E10 3D12-1 C14 3D16-2 D14 3D17-3 B14 3D20-2 H8 3D21-3 B14 3D26 H11 4D05 I4 5D03 I2 7D04 G9 7D04 G9 FD04 C9 FD08 G1 FD09 G1 FD10 I2 FD13 G9 ID00 H1 ID01 H2 ID08 H10 ID09 H11 ID10 G10 ID11 H11 ID13 E15 ID20 A9 ID22 A9 ID24 I5
2D09 B1 2D14 B2 2D21 E2 2D29 C1 2D35 E2 2D42 G2 2D47 I2 2D52 G10 2D57 H10 3D02 B9 3D08 E10 3D15-2 C14 3D16-3 D14 3D17-4 A14 3D20-3 H8 3D21-4 B14 3D27 H4 4D06 I4 5D04 I2 7D02 H1 7D05 H4 7D05 H4 FD05 E15 FD10 I2 FD15 G9 ID00 H1 ID01 H2 ID08 H10 ID09 H11 ID10 G10 ID11 H11 ID13 E15 ID20 A9 ID22 A9 ID24 I5

1 2 3 4 5 6 7 8 9 10 11 12 13 14 15

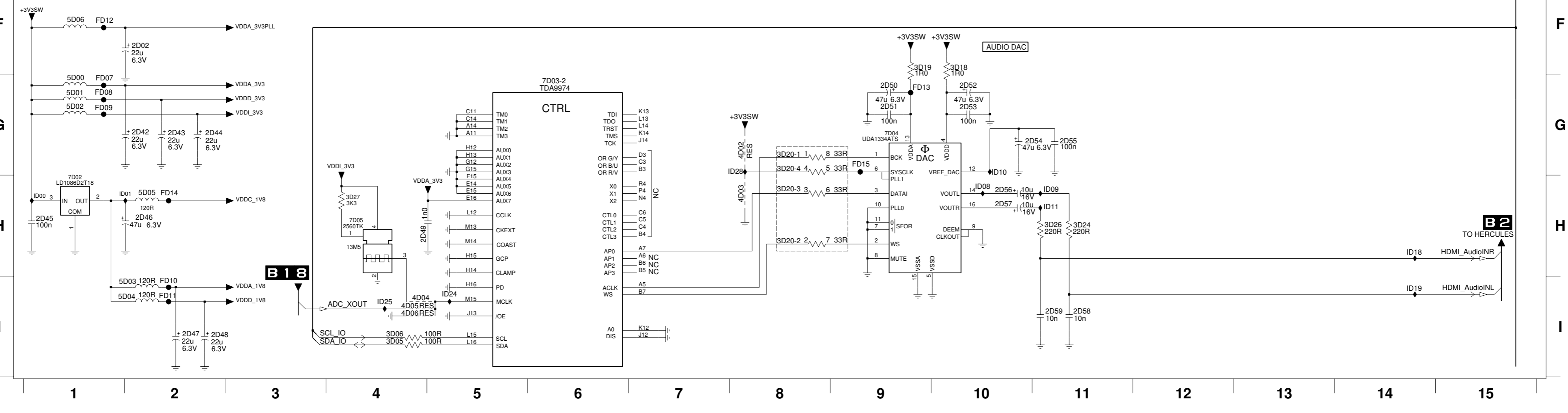
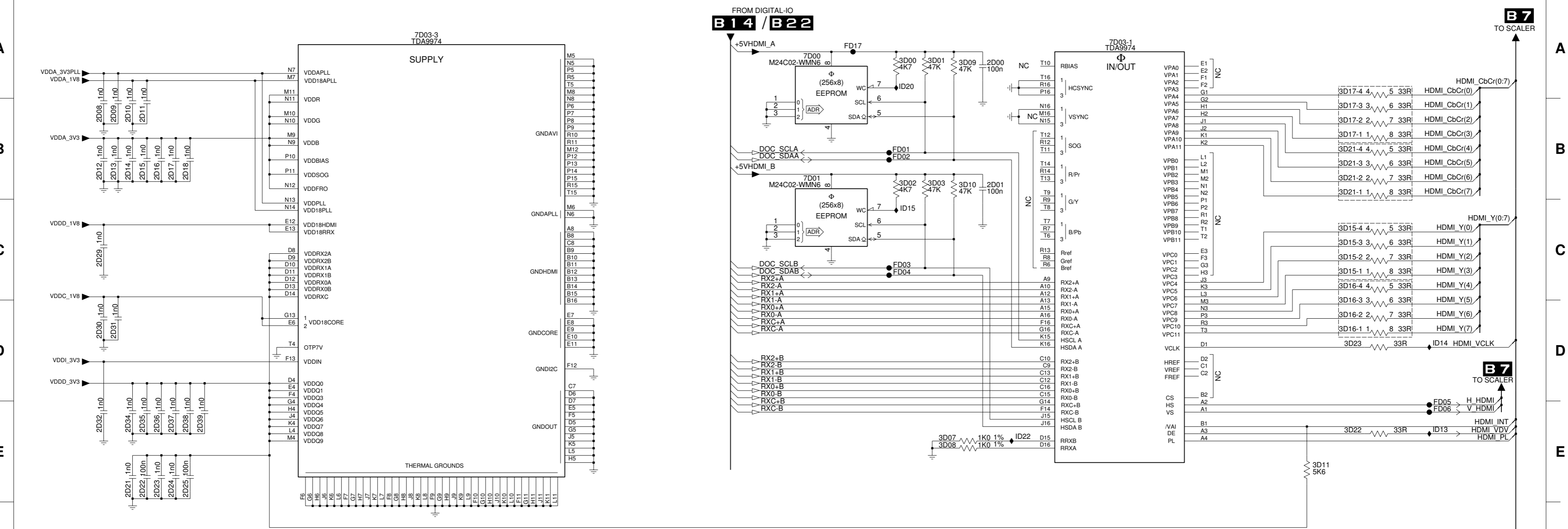

B12 HDMI

SSB SCART LC04SD2.1 MULTIPLE 12NC - 3139_123_61163_01 / 3139_123_61241_02
SSB SCART LC04SD2.1 SINGLE 12NC - 3139_123_61173_01 / 3139_123_61251_02
CELL 12NC - 8239_125_12113

"D00" ~ "D99"

1 2 3 4 5 6 7 8 9 10 11 12 13 14 15 16 17 18 19 20

1 2 3 4 5 6 7 8 9 10 11 12 13

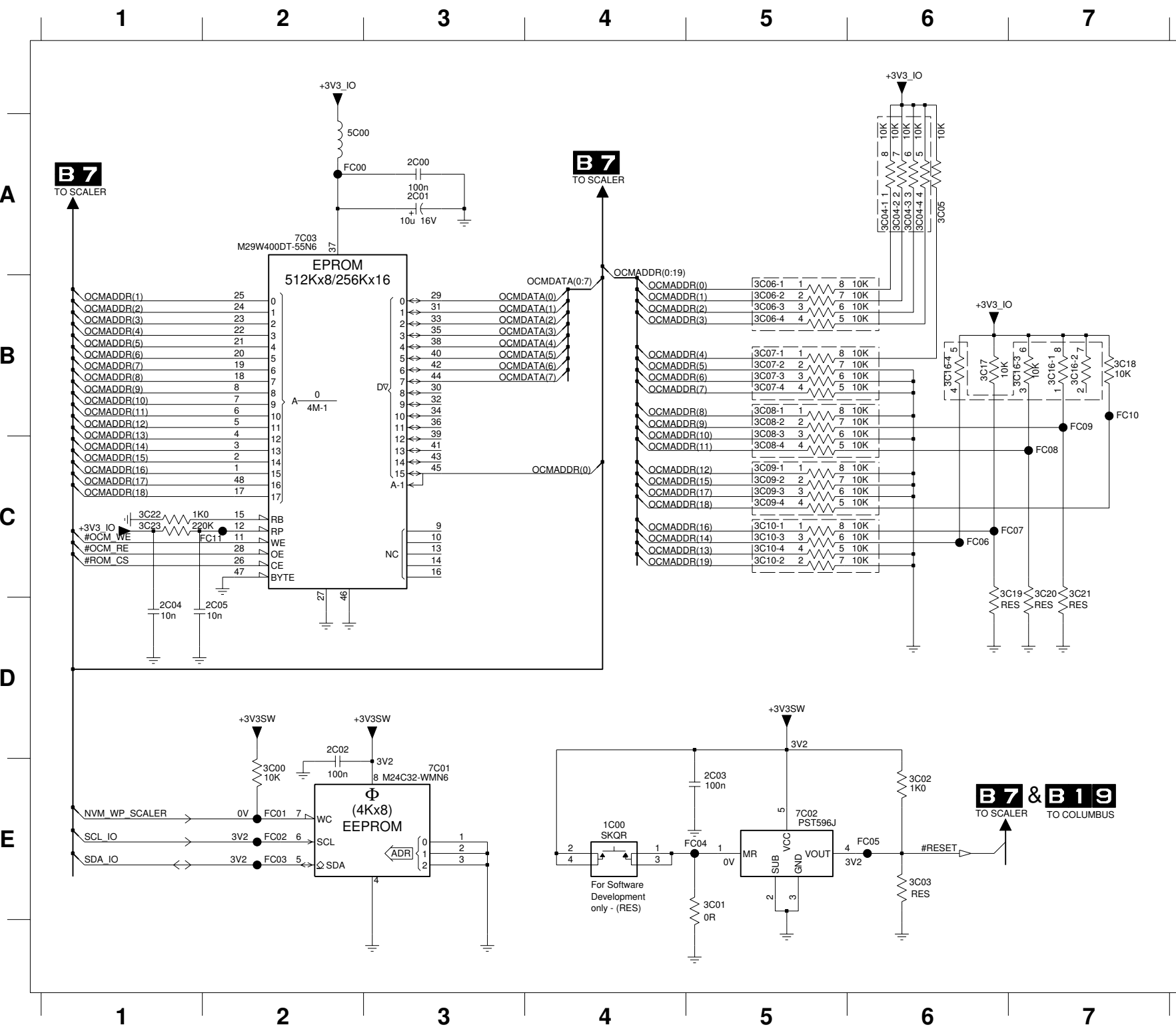

- 1C00 E4
- 2C00 A3
- 2C01 A3
- 2C02 D2
- 2C03 E5
- 2C04 D1
- 2C05 D2
- 3C00 E2
- 3C01 E5
- 3C02 E6
- 3C03 E6
- 3C04-1 A6
- 3C04-2 A6
- 3C04-3 A6
- 3C04-4 A6
- 3C05 A6
- 3C06-1 B5
- 3C06-2 B5
- 3C06-3 B5
- 3C06-4 B5
- 3C07-1 B5
- 3C07-2 B5
- 3C07-3 B5
- 3C07-4 B5
- 3C08-1 B5
- 3C08-2 B5
- 3C08-3 C5
- 3C08-4 C5
- 3C09-1 C5
- 3C09-2 C5
- 3C09-3 C5
- 3C09-4 C5
- 3C10-1 C5
- 3C10-2 C5
- 3C10-3 C5
- 3C10-4 C5
- 3C16-1 B7
- 3C16-2 B7
- 3C16-3 B7
- 3C16-4 B6
- 3C17 B6
- 3C18 B7
- 3C19 C7
- 3C20 C7
- 3C21 C7
- 3C22 C1
- 3C23 C1
- 5C00 A2
- 7C01 E3
- 7C02 E5
- 7C03 A2
- FC00 A2
- FC01 E2
- FC02 E2
- FC03 E2
- FC04 E5
- FC05 E6
- FC06 C6
- FC07 C7
- FC08 C7
- FC09 B7
- FC10 B7
- FC11 C2

B 11 FLASH / CONTROL

SSB SCART LC04SD2.1 MULTIPLE 12NC :- 3139_123_61163_01 / 3139_123_61241_02
 SSB SCART LC04SD2.1 SINGLE 12NC :- 3139_123_61173_01 / 3139_123_61251_02
 CELL 12NC :- 8239_125_12113

"C00" ~ "C99"

1 2 3 4 5 6 7 8 9 10 11 12 13

PHILIPS

All rights reserved. Reproduction in whole or in parts is prohibited without the written consent of the copyright owner.

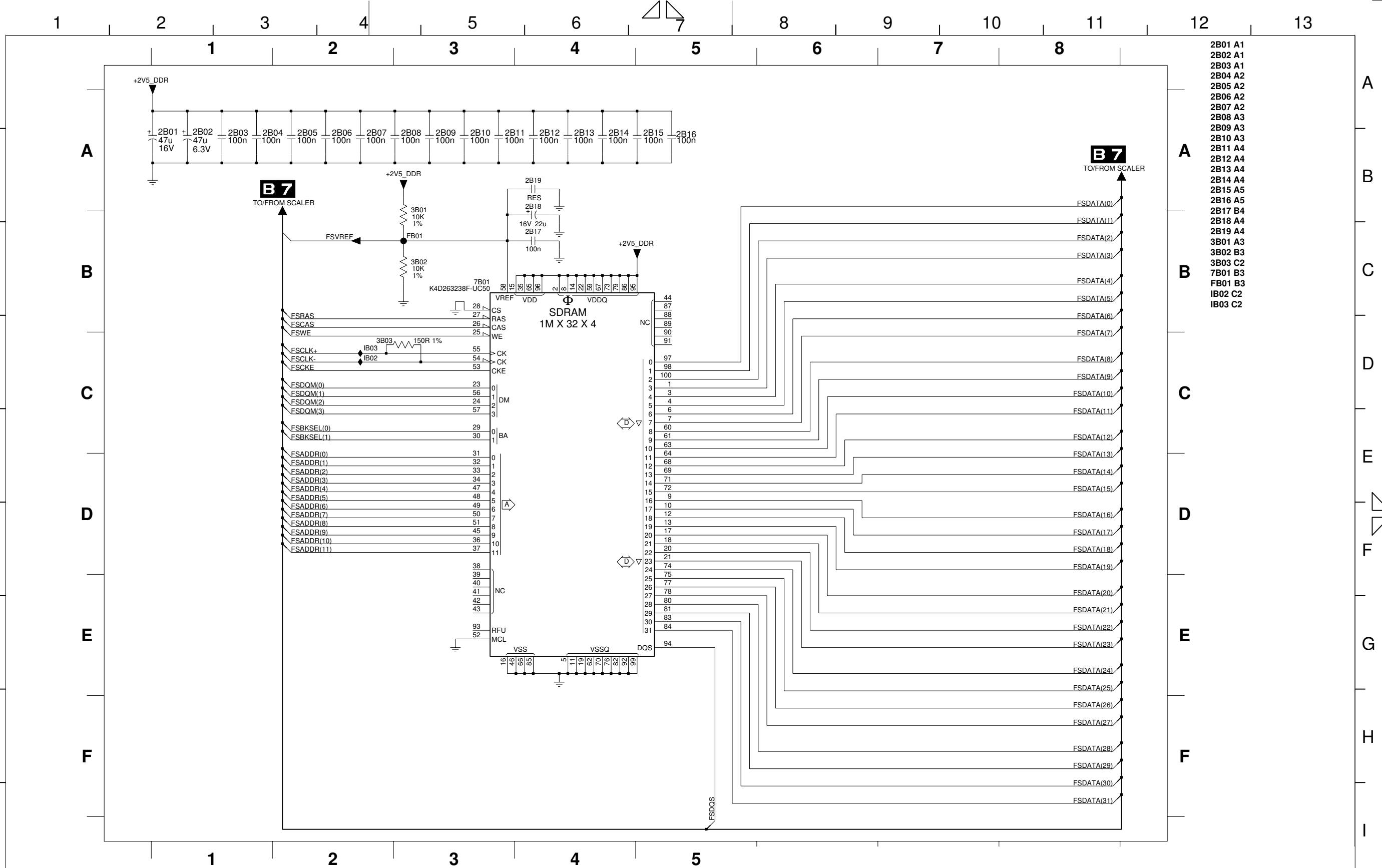

- 2B01 A1
- 2B02 A1
- 2B03 A1
- 2B04 A2
- 2B05 A2
- 2B06 A2
- 2B07 A2
- 2B08 A3
- 2B09 A3
- 2B10 A3
- 2B11 A4
- 2B12 A4
- 2B13 A4
- 2B14 A4
- 2B15 A5
- 2B16 A5
- 2B17 B4
- 2B18 A4
- 2B19 A4
- 3B01 A3
- 3B02 B3
- 3B03 C2
- 7B01 B3
- IB01 B3
- IB02 C2
- IB03 C2

B 10 SDRAM

SSB SCART LC04SD2.1 MULTIPLE 12NC :- 3139_123_61163_01 / 3139_123_61241_02
 SSB SCART LC04SD2.1 SINGLE 12NC :- 3139_123_61173_01 / 3139_123_61251_02
 CELL 12NC :- 8239_125_12113

"B00" ~ "B99"

1 2 3 4 5 6 7 8 9 10 11 12 13

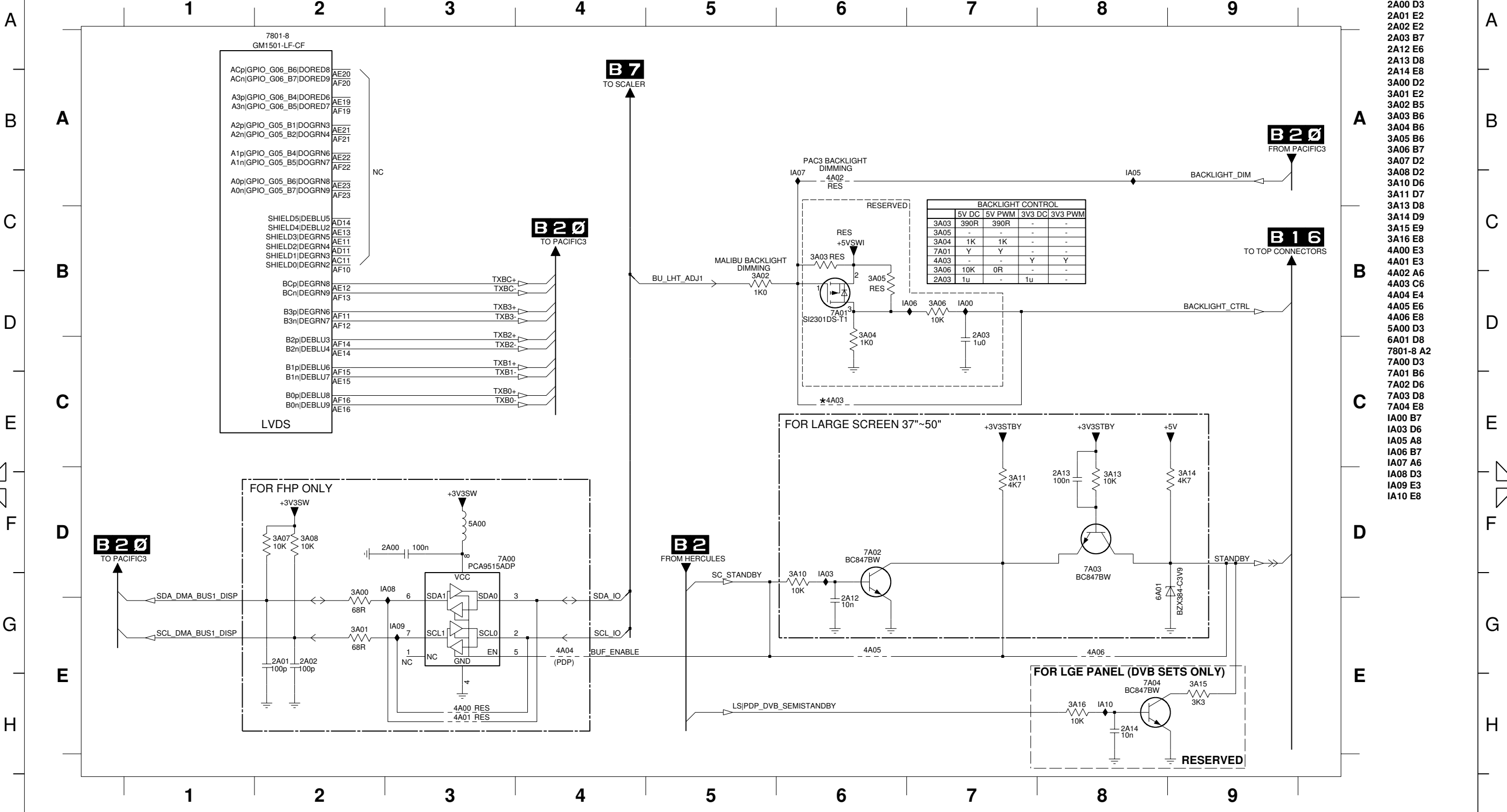

- 2A00 D3
- 2A01 E2
- 2A02 E2
- 2A03 B7
- 2A12 E6
- 2A13 D8
- 2A14 E8
- 3A00 D2
- 3A01 E2
- 3A02 B5
- 3A03 B6
- 3A04 B6
- 3A05 B6
- 3A06 B7
- 3A07 D2
- 3A08 D2
- 3A10 D6
- 3A11 D7
- 3A13 D8
- 3A14 D9
- 3A15 E9
- 3A16 E8
- 4A00 E3
- 4A01 E3
- 4A02 A6
- 4A03 C6
- 4A04 E4
- 4A05 E6
- 4A06 E8
- 5A00 D3
- 6A01 D8
- 7801-8 A2
- 7A00 D3
- 7A01 B6
- 7A02 D6
- 7A03 D8
- 7A04 E8
- IA00 B7
- IA03 D6
- IA05 A8
- IA06 B7
- IA07 A6
- IA08 D3
- IA09 E3
- IA10 E8

B9 SCALER INTERFACE

SSB SCART LC04SD2.1 MULTIPLE 12NC :- 3139_123_61163_01 / 3139_123_61241_02
 SSB SCART LC04SD2.1 SINGLE 12NC :- 3139_123_61173_01 / 3139_123_61251_02
 CELL 12NC :- 8239_125_12113

"A00" ~ "A99"

1 2 3 4 5 6 7 8 9 10 11 12 13

All rights reserved. Reproduction in whole or in parts is prohibited without the written consent of the copyright owner.

PHILIPS

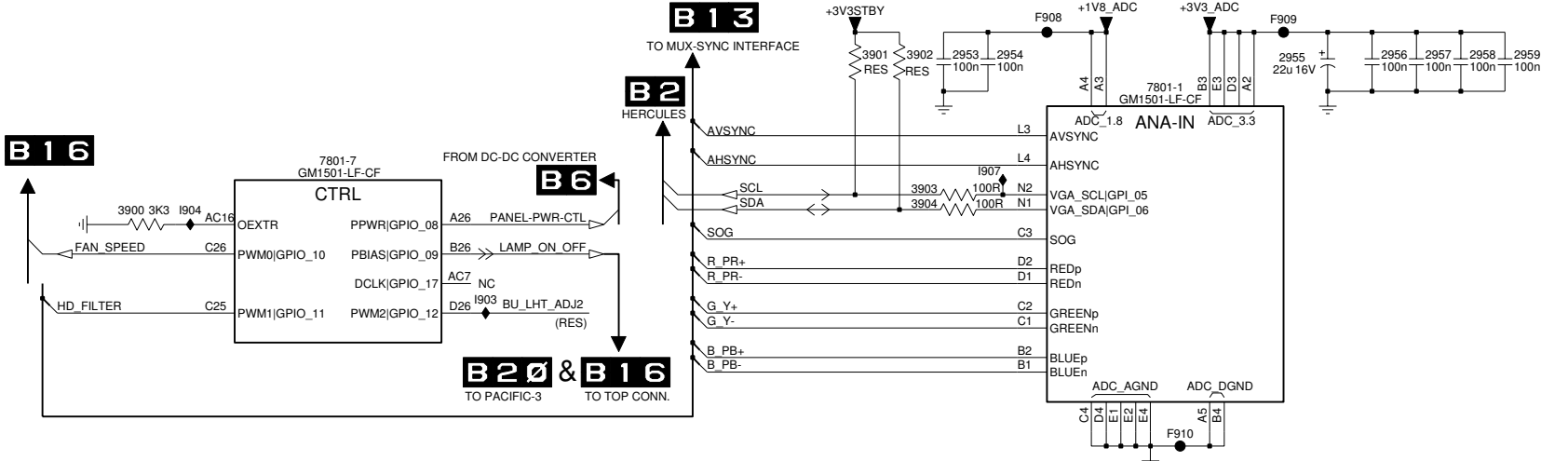
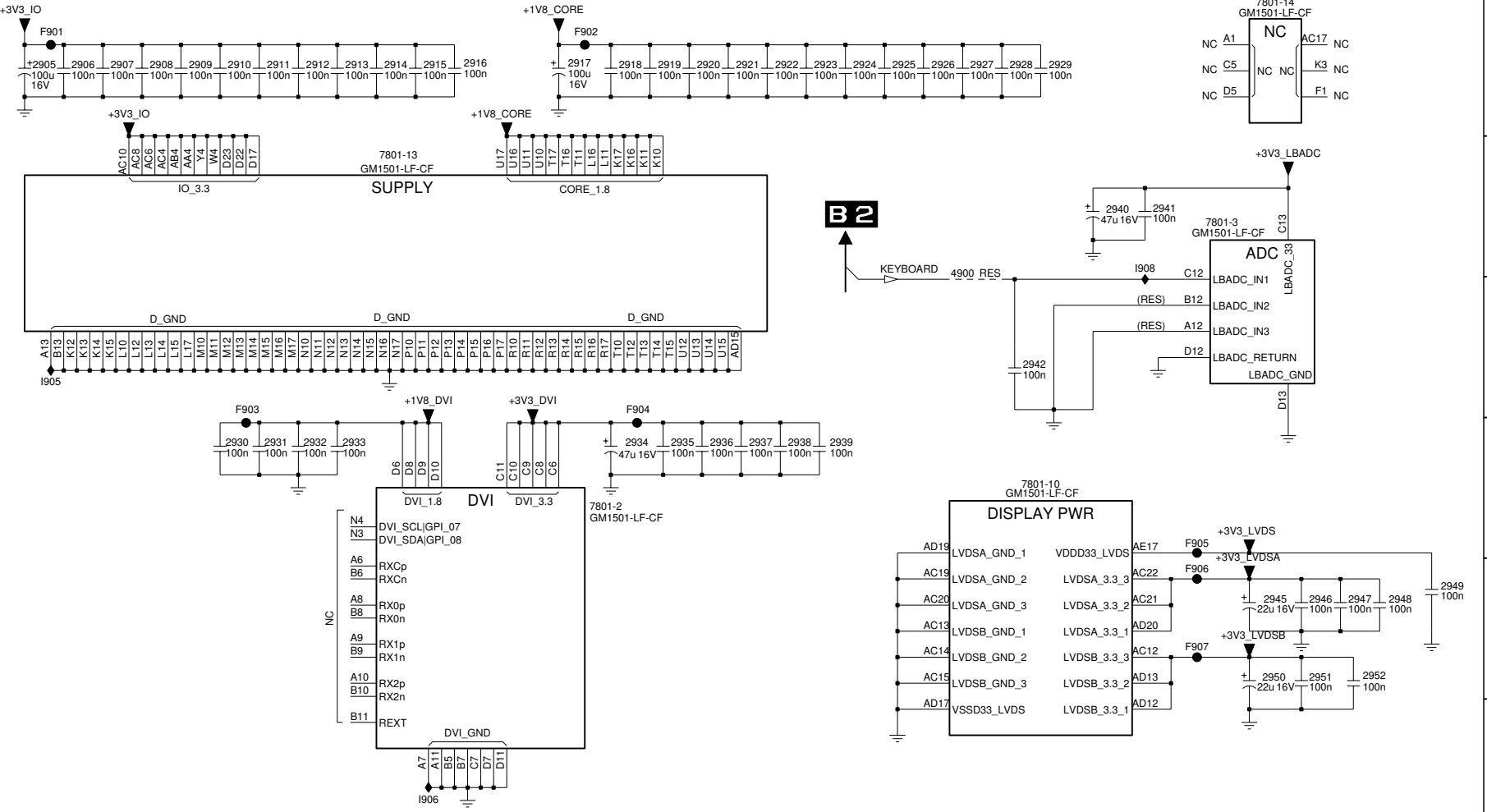
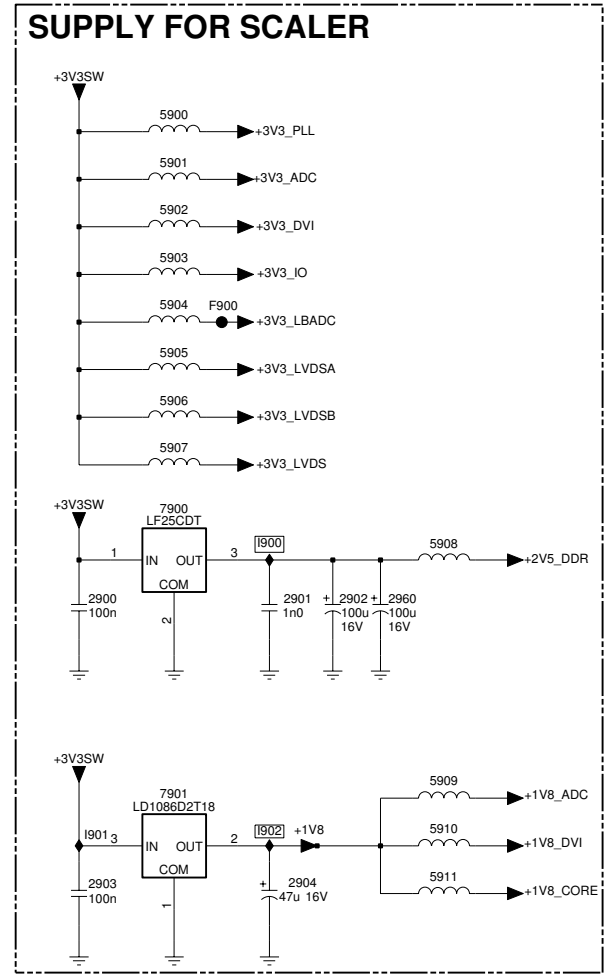

B8 SCALER

SSB SCART LC04SD2.1 MULTIPLE 12NC :- 3139_123_61163_01 / 3139_123_61241_02
 SSB SCART LC04SD2.1 SINGLE 12NC :- 3139_123_61173_01 / 3139_123_61251_02
 CELL 12NC :- 8239_125_12113

"900" ~ "999"

- 2900 C2
- 2901 C3
- 2902 C3
- 2903 E2
- 2904 E3
- 2905 A4
- 2906 A5
- 2907 A5
- 2908 A5
- 2909 A5
- 2910 A5
- 2911 A6
- 2912 A6
- 2913 A6
- 2914 A6
- 2915 A6
- 2916 A7
- 2917 A7
- 2918 A8
- 2919 A8
- 2920 A8
- 2921 A8
- 2922 A8
- 2923 A9
- 2924 A9
- 2925 A9
- 2926 A9
- 2927 A9
- 2928 A10
- 2929 A10
- 2930 C5
- 2931 C6
- 2932 C6
- 2933 C6
- 2934 C8
- 2935 C8
- 2936 C8
- 2937 C8
- 2938 C8
- 2939 C9
- 2940 B10
- 2941 B10
- 2942 C10
- 2945 D11
- 2946 D11
- 2947 D12
- 2948 D12
- 2949 D12
- 2950 D11
- 2951 D11
- 2952 D12
- 2953 E9
- 2954 E9
- 2955 E10
- 2956 E11
- 2957 E11
- 2958 E11
- 2959 E12
- 2960 C3
- 3900 F5
- 3901 E8
- 3902 E9
- 3903 F9
- 3904 F9
- 4900 B9
- 5900 A2
- 5901 A2
- 5902 B2
- 5903 B2
- 5904 B2
- 5905 B2
- 5906 C2
- 5907 C2
- 5908 C3
- 5909 D3
- 5910 D3
- 5911 E3
- 7801-1 E10
- 7801-10 C10
- 7801-13 A6
- 7801-14 A11
- 7801-2 C7
- 7801-3 B11
- 7801-7 F6
- 7900 C2
- 7901 D2
- F900 B2
- F901 A4
- F902 A7
- F903 C5
- F904 C8
- F905 D11
- F906 D11
- F907 D11
- F908 E9
- F909 E10
- F910 G10
- I900 C2
- I901 D2
- I902 D2
- I903 F7
- I904 F5
- I905 C4
- I906 E6
- I907 F9
- I908 B10

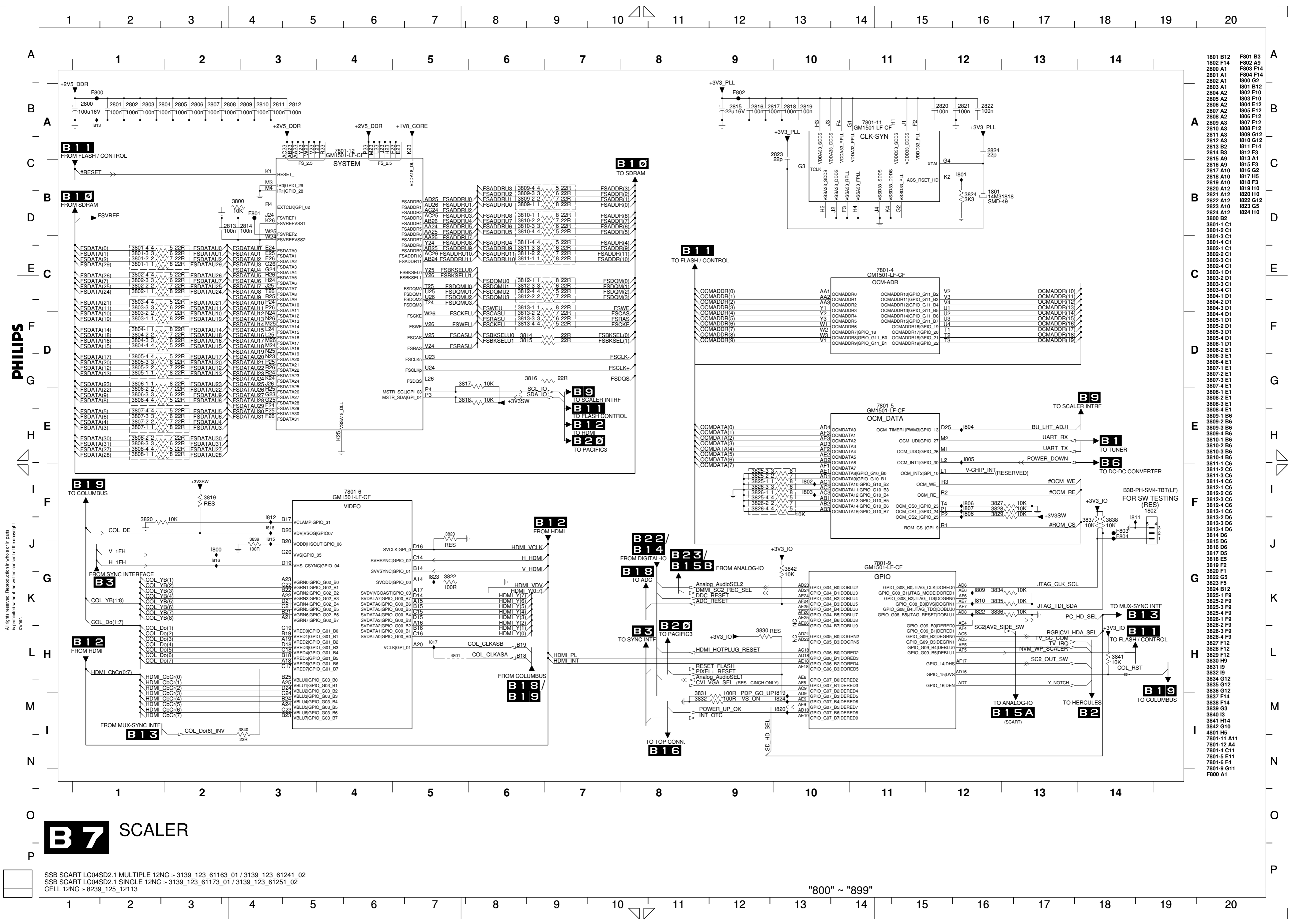

All rights reserved. Reproduction in whole or in parts is prohibited without the written consent of the copyright owner.

B7 SCALER

SSB SCART LC04SD2.1 MULTIPLE 12NC - 3139_123_61163_01 / 3139_123_61241_02
 SSB SCART LC04SD2.1 SINGLE 12NC - 3139_123_61173_01 / 3139_123_61251_02
 CELL 12NC - 8239_125_12113

"800" ~ "899"

- 1801 B12
- 1802 F14
- 2800 A1
- 2801 A1
- 2802 A1
- 2803 A1
- 2804 A2
- 2805 A2
- 2806 A2
- 2807 A2
- 2808 A2
- 2809 A3
- 2810 A3
- 2811 A3
- 2812 A3
- 2813 B2
- 2814 B3
- 2815 A9
- 2816 A9
- 2817 A10
- 2818 A10
- 2819 A10
- 2820 A12
- 2821 A12
- 2822 A10
- 2823 A10
- 2824 A12
- 3800 A3
- 3801-C1
- 3801-2 C1
- 3801-3 C1
- 3801-4 C1
- 3802-C1
- 3802-2 C1
- 3802-3 C1
- 3802-4 C1
- 3803-C1
- 3803-1 D1
- 3803-2 D1
- 3803-3 D1
- 3803-4 D1
- 3804-C1
- 3804-2 D1
- 3804-3 D1
- 3804-4 D1
- 3805-D1
- 3805-1 D1
- 3805-2 D1
- 3805-3 D1
- 3805-4 D1
- 3806-C1
- 3806-2 E1
- 3806-3 E1
- 3806-4 E1
- 3807-E1
- 3807-2 E1
- 3807-3 E1
- 3807-4 E1
- 3808-E1
- 3808-1 E1
- 3808-2 E1
- 3808-3 E1
- 3808-4 E1
- 3809-B6
- 3809-2 B6
- 3809-3 B6
- 3809-4 B6
- 3810-B6
- 3810-2 B6
- 3810-3 B6
- 3810-4 B6
- 3811-C6
- 3811-2 C6
- 3811-3 C6
- 3811-4 C6
- 3812-C6
- 3812-2 C6
- 3812-3 C6
- 3812-4 C6
- 3813-C6
- 3813-2 D6
- 3813-3 D6
- 3813-4 D6
- 3814-D6
- 3815-D6
- 3816-D6
- 3817-D5
- 3818-E5
- 3819-F2
- 3820-F1
- 3822-G5
- 3823-F5
- 3824-B12
- 3825-1 F9
- 3825-2 F9
- 3825-3 F9
- 3825-4 F9
- 3825-5 F9
- 3825-6 F9
- 3825-7 F9
- 3825-8 F9
- 3825-9 F9
- 3826-1 F9
- 3826-2 F9
- 3826-3 F9
- 3826-4 F9
- 3826-5 F9
- 3826-6 F9
- 3826-7 F9
- 3826-8 F9
- 3826-9 F9
- 3827-F12
- 3828-F12
- 3829-F12
- 3830-H9
- 3831-I9
- 3832-I9
- 3833-G12
- 3834-G12
- 3835-G12
- 3837-F14
- 3838-F14
- 3839-G3
- 3840-I3
- 3841-H14
- 3842-G10
- 4801-H5
- 7801-11 A11
- 7801-12 A4
- 7801-4 C11
- 7801-5 E11
- 7801-6 F4
- 7801-9 G11
- F800 A1

All rights reserved. Reproduction in whole or in parts is prohibited without the written consent of the copyright owner.

PHILIPS

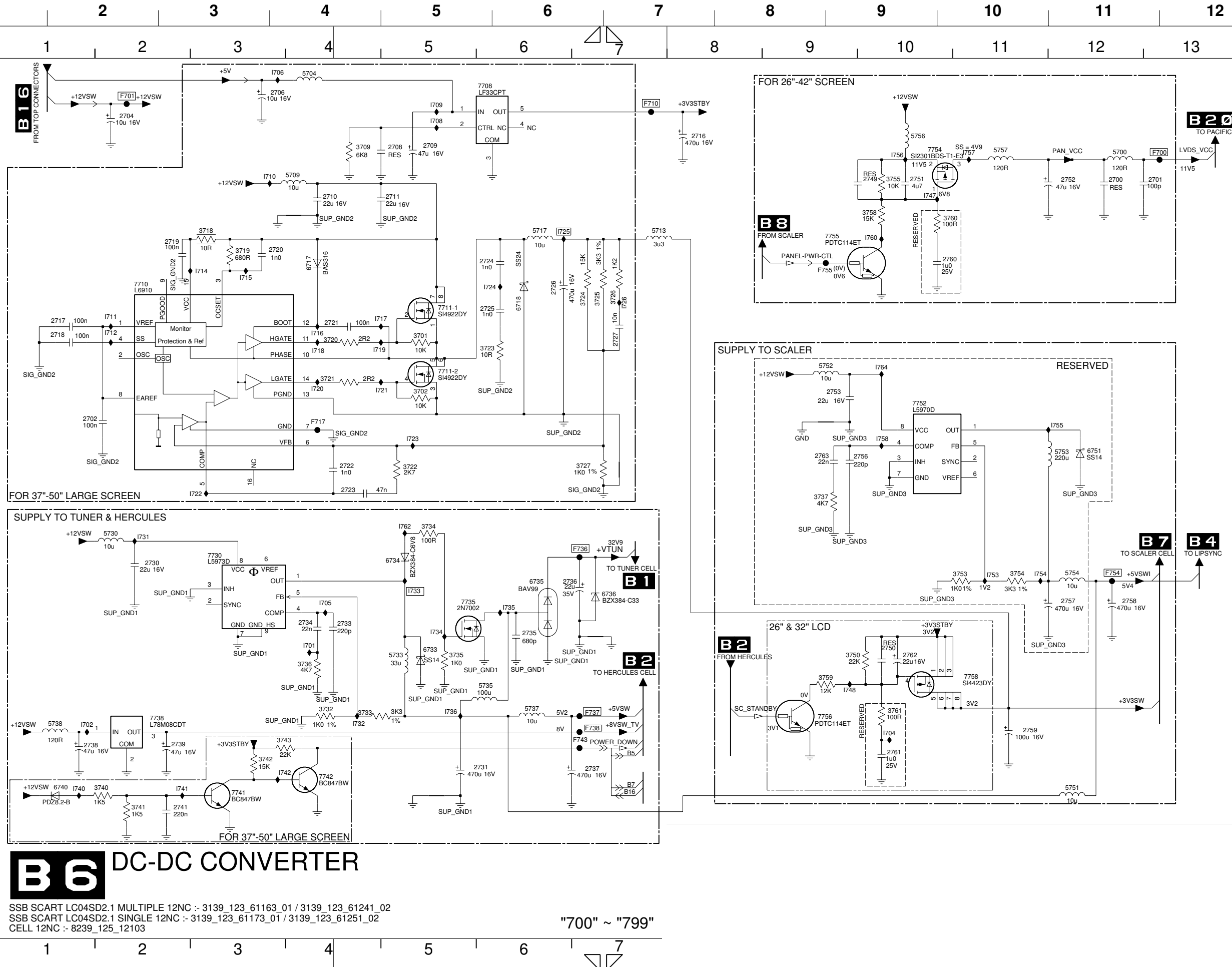

B6 DC-DC CONVERTER

SSB SCART LC04SD2.1 MULTIPLE 12NC :- 3139_123_61163_01 / 3139_123_61241_02
 SSB SCART LC04SD2.1 SINGLE 12NC :- 3139_123_61173_01 / 3139_123_61251_02
 CELL 12NC :- 8239_125_12103

"700" ~ "799"

- 2700 B11
- 2701 B11
- 2702 D2
- 2704 A2
- 2706 A4
- 2708 A5
- 2709 A5
- 2710 B4
- 2711 B5
- 2716 A7
- 2717 C2
- 2718 C2
- 2719 B3
- 2720 B4
- 2721 C4
- 2722 D4
- 2723 D4
- 2724 B5
- 2725 C5
- 2726 C6
- 2727 C7
- 2730 E2
- 2731 G5
- 2733 F4
- 2734 F4
- 2735 F6
- 2736 E6
- 2737 G6
- 2738 G2
- 2739 G3
- 2740 G3
- 2749 B9
- 2750 F9
- 2751 B9
- 2752 B11
- 2753 D9
- 2756 D9
- 2757 E11
- 2758 E11
- 2759 G10
- 2760 B10
- 2761 G9
- 2762 F9
- 2763 D8
- 3701 C5
- 3702 D5
- 3709 A4
- 3718 B3
- 3719 B3
- 3720 C4
- 3721 C4
- 3722 D5
- 3723 C5
- 3724 C6
- 3725 C6
- 3726 C7
- 3727 D6
- 3732 F4
- 3733 F4
- 3734 E5
- 3735 F5
- 3736 F4
- 3737 D8
- 3740 G2
- 3741 G2
- 3742 G3
- 3743 G4
- 3744 G3
- 3745 F5
- 3746 E6
- 3747 B9
- 3748 F9
- 3749 E10
- 3750 E10
- 3751 G11
- 3752 D11
- 3753 D11
- 3754 E11
- 3755 A9
- 3756 A9
- 3757 A10
- 3758 B9
- 3759 F9
- 3760 B10
- 3761 F9
- 5700 A11
- 5704 A4
- 5709 B4
- 5713 B7
- 5717 B6
- 5730 E2
- 5733 F5
- 5735 F5
- 5737 F6
- 5738 G2
- 5751 G11
- 5752 C9
- 5753 D11
- 5754 E11
- 5756 A9
- 5757 A10
- 6717 B4
- 6733 F5
- 6734 E5
- 6735 E6
- 6736 E7
- 6740 G2
- 6751 D11
- 7708 A5
- 7710 C2
- 7711-C5
- 7711-2 C5
- 7730 E3
- 7735 E5
- 7738 F2
- 7741 G3
- 7742 G4
- 7752 D9
- 7754 A10
- 7755 B8
- 7756 F8
- 7758 F10
- 7700 A12
- 7701 A2
- 7710 A7
- 7717 D4
- 7736 E6
- 7737 F6
- 7738 G6
- 7743 G6
- 7754 E11
- 7755 B8
- 1701 F4
- 1702 G2
- 1704 G9
- 1705 E4
- 1706 A4
- 1708 A5
- 1709 A5
- 1710 B4
- 1711 C2
- 1712 C2
- 1714 B3
- 1715 C3
- 1716 C4
- 1717 C5
- 1718 C4
- 1719 C4
- 1720 D4
- 1721 D5
- 1722 D3
- 1723 D5
- 1724 C5
- 1725 B6
- 1726 C7
- 1731 E2
- 1732 G4
- 1733 E5
- 1734 F5
- 1735 E6
- 1736 F5
- 1740 G2
- 1741 G3
- 1742 G4
- 1747 B9
- 1748 F9
- 1753 E10
- 1754 E10
- 1755 D11
- 1756 A9
- 1757 A10
- 1758 D9
- 1760 B9
- 1762 E5
- 1764 C9

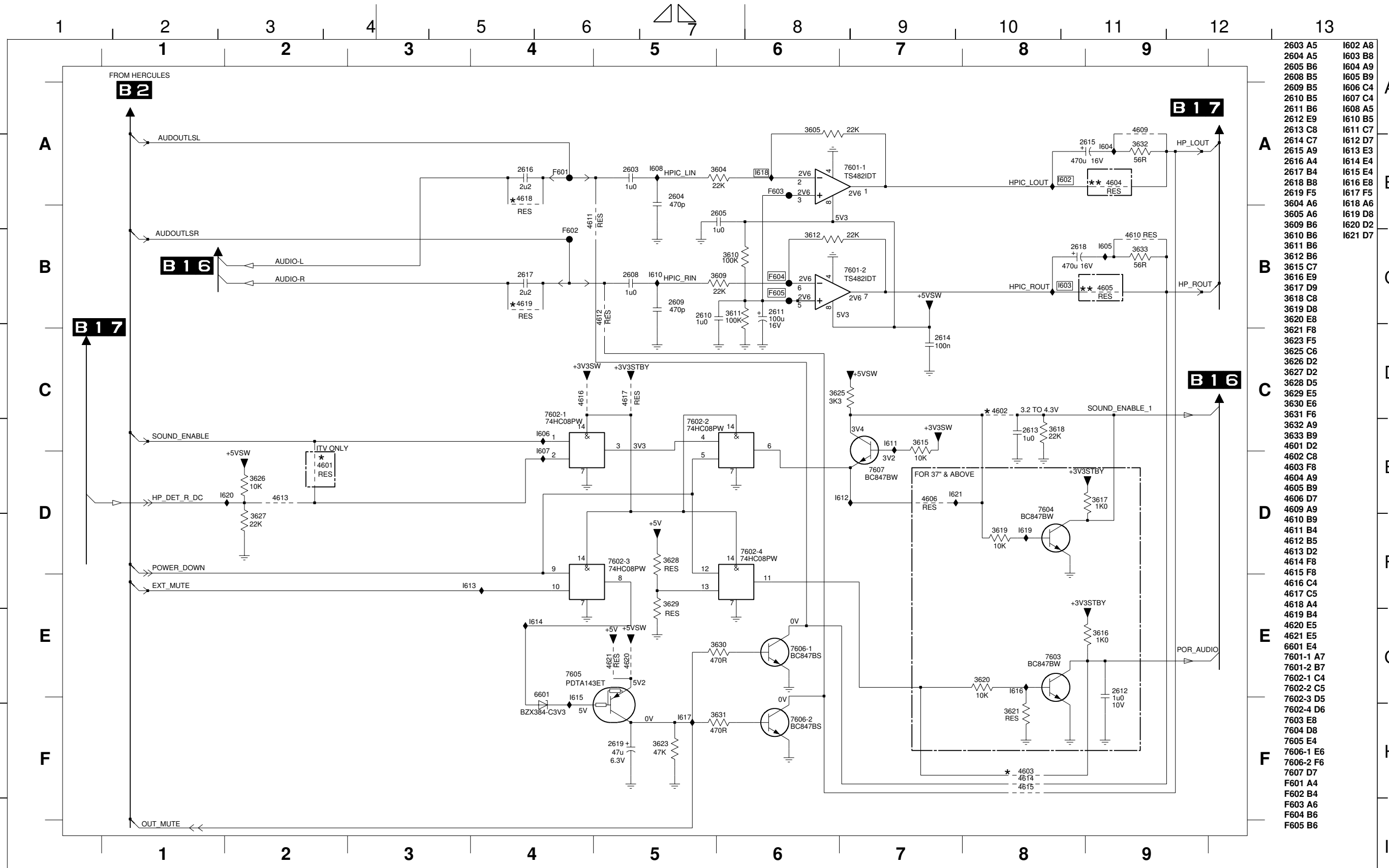

2603 A5	I602 A8
2604 A5	I603 B8
2605 B6	I604 A9
2608 B5	I605 B9
2609 B5	I606 C4
2610 B5	I607 C4
2611 B6	I608 A5
2612 E9	I610 B5
2613 C8	I611 C7
2614 C7	I612 D7
2615 A9	I613 E3
2616 A4	I614 E4
2617 B4	I615 E4
2618 B8	I616 E8
2619 F5	I617 F5
3604 A6	I618 A6
3605 A6	I619 D8
3609 B6	I620 D2
3610 B6	I621 D7
3611 B6	
3612 B6	
3615 C7	
3616 E9	
3617 D9	
3618 C8	
3619 D8	
3620 E8	
3621 F8	
3623 F5	
3625 C6	
3626 D2	
3627 D2	
3628 D5	
3629 E5	
3630 E6	
3631 F6	
3632 A9	
3633 B9	
4601 D2	
4602 C8	
4603 F8	
4604 A9	
4605 B9	
4606 D7	
4609 A9	
4610 B9	
4611 B4	
4612 B5	
4613 D2	
4614 F8	
4615 F8	
4616 C4	
4617 C5	
4618 A4	
4619 B4	
4620 E5	
4621 E5	
6601 E4	
7601-1 A7	
7601-2 B7	
7602-1 C4	
7602-2 C5	
7602-3 D5	
7602-4 D6	
7603 E8	
7604 D8	
7605 E4	
7606-1 E6	
7606-2 F6	
7607 D7	
F601 A4	
F602 B4	
F603 A6	
F604 B6	
F605 B6	

B5 AUDIO PROCESSING

SSB SCART LC04SD2.1 MULTIPLE 12NC :- 3139_123_61163_01 / 3139_123_61241_02
 SSB SCART LC04SD2.1 SINGLE 12NC :- 3139_123_61173_01 / 3139_123_61251_02
 CELL 12NC :- 8239_125_12093

"600"~"699"

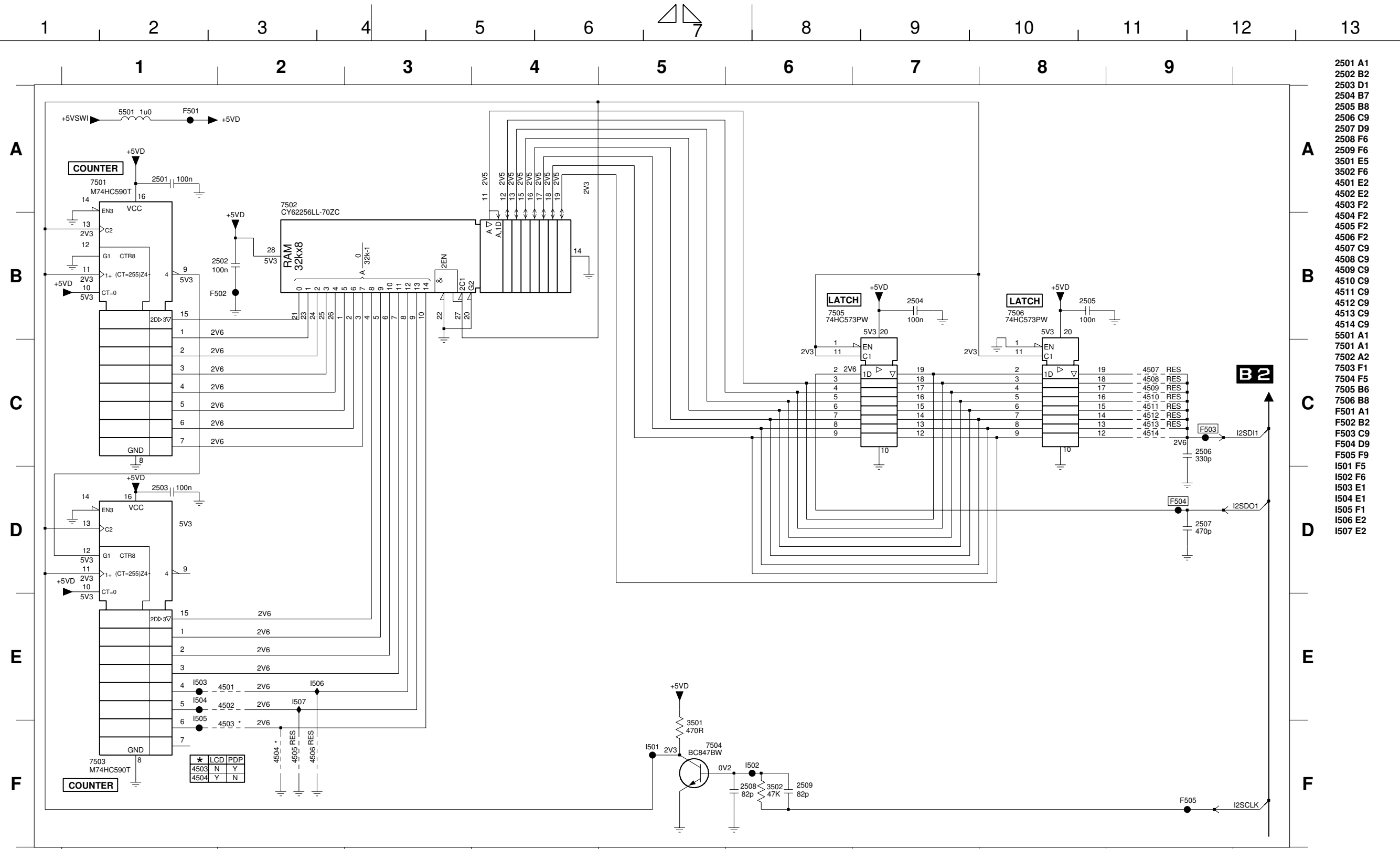

- 2501 A1
- 2502 B2
- 2503 D1
- 2504 B7
- 2505 B8
- 2506 C9
- 2507 D9
- 2508 F6
- 2509 F6
- 3501 E5
- 3502 F6
- 4501 E2
- 4502 E2
- 4503 F2
- 4504 F2
- 4505 F2
- 4506 F2
- 4507 C9
- 4508 C9
- 4509 C9
- 4510 C9
- 4511 C9
- 4512 C9
- 4513 C9
- 4514 C9
- 5501 A1
- 5501 A1
- 5502 A2
- 7503 F1
- 7504 F5
- 7505 B6
- 7506 B8
- F501 A1
- F502 B2
- F503 C9
- F504 D9
- F505 F9
- I501 F5
- I502 F6
- I503 E1
- I504 E1
- I505 F1
- I506 E2
- I507 E2

B4 AUDIO DELAY LINE (LIPSYNC)

SSB SCART LC04SD2.1 MULTIPLE 12NC :- 3139_123_61163_01 / 3139_123_61241_02
 SSB SCART LC04SD2.1 SINGLE 12NC :- 3139_123_61173_01 / 3139_123_61251_02
 CELL 12NC :- 8239_125_12093

"500" ~ "599"



1 2 3 4 5 6 7 8 9 10 11 12 13

1 2 3 4 5 6 7 8 9

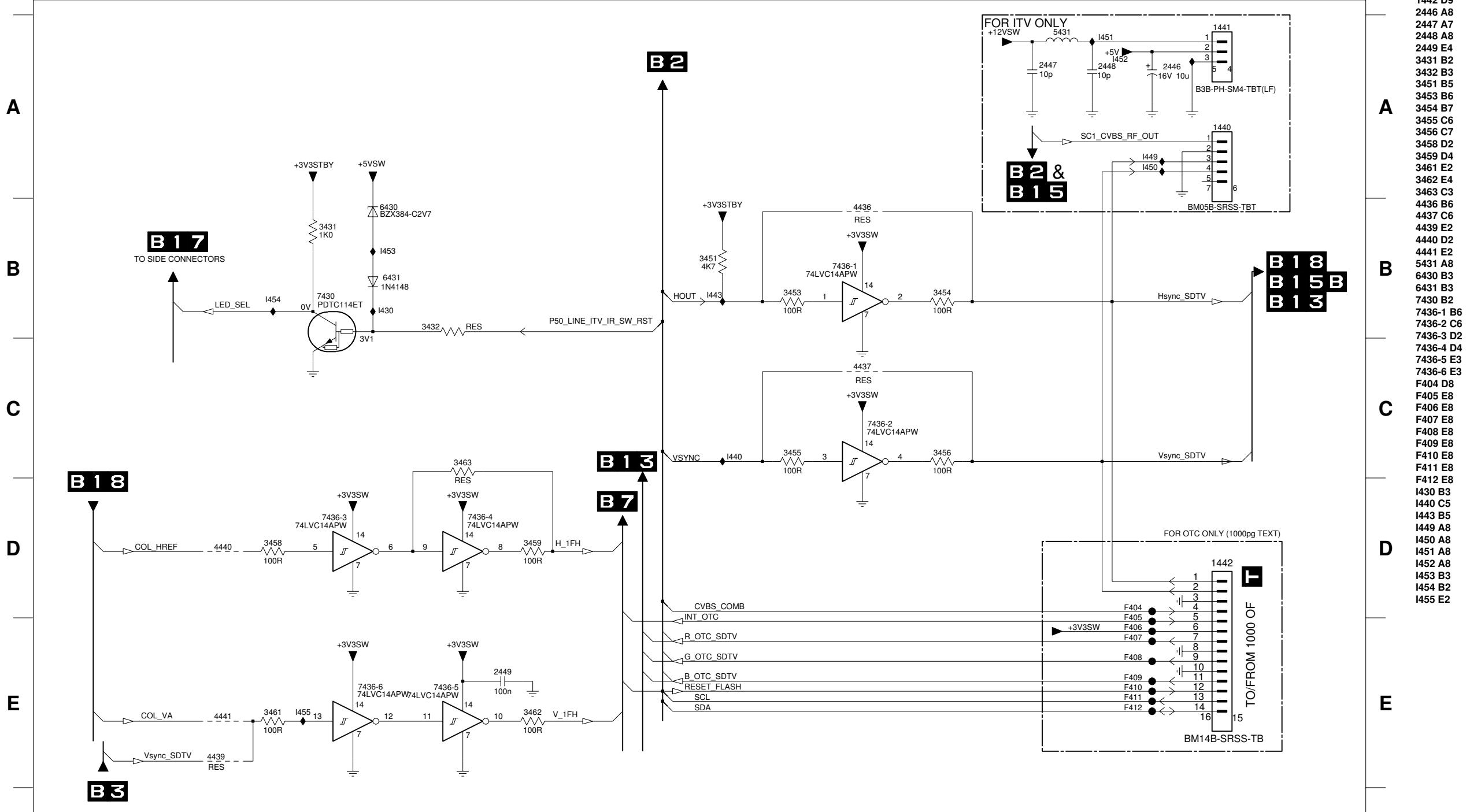

- 1440 A9
- 1441 A9
- 1442 D9
- 2446 A8
- 2447 A7
- 2448 A8
- 2449 E4
- 3431 B2
- 3432 B3
- 3451 B5
- 3453 B6
- 3454 B7
- 3455 C6
- 3456 C7
- 3458 D2
- 3459 D4
- 3461 E2
- 3462 E4
- 3463 C3
- 4436 B6
- 4437 C6
- 4439 E2
- 4440 D2
- 4441 E2
- 5431 A8
- 6430 B3
- 6431 B3
- 7430 B2
- 7436-1 B6
- 7436-2 C6
- 7436-3 D2
- 7436-4 D4
- 7436-5 E3
- 7436-6 E3
- F404 D8
- F405 E8
- F406 E8
- F407 E8
- F408 E8
- F409 E8
- F410 E8
- F411 E8
- F412 E8
- I430 B3
- I440 C5
- I443 B5
- I449 A8
- I450 A8
- I451 A8
- I452 A8
- I453 B3
- I454 B2
- I455 E2

B3 SYNC INTERFACE

SSB SCART LC04SD2.1 MULTIPLE 12NC :- 3139_123_61163_01 / 3139_123_61241_02
 SSB SCART LC04SD2.1 SINGLE 12NC :- 3139_123_61173_01 / 3139_123_61251_02
 CELL 12NC :- 8239_125_12093

"400" ~ "499"

1 2 3 4 5 6 7 8 9 10 11 12 13

All rights reserved. Reproduction in whole or in parts is prohibited without the written consent of the copyright owner.

PHILIPS

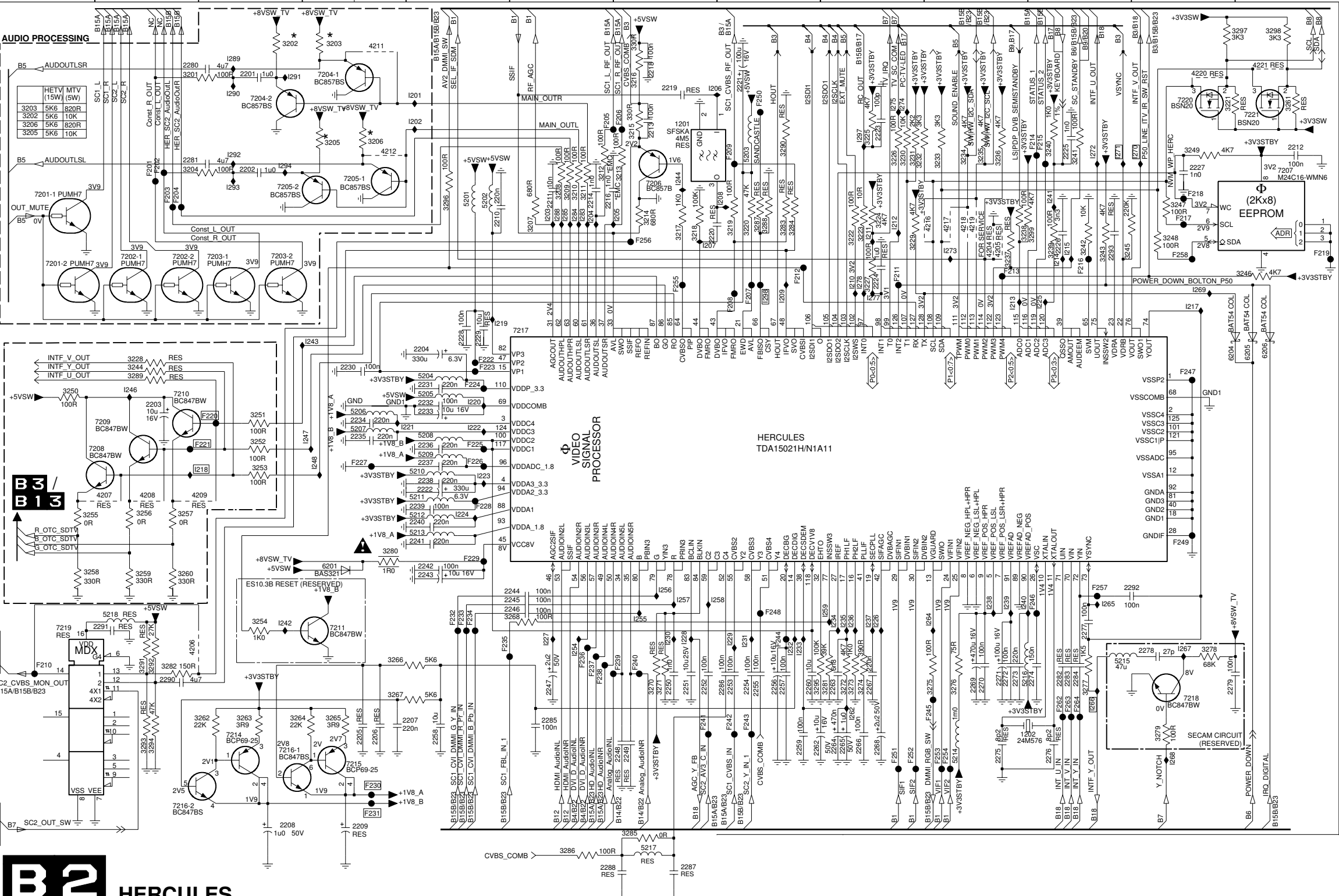

SSB SCART LC04SD2.1 MULTIPLE 12NC :- 3139_123_61163_01 / 3139_123_61241_02
SSB SCART LC04SD2.1 SINGLE 12NC :- 3139_123_61173_01 / 3139_123_61251_02
CELL 12NC :- 8239_125_12093

"200"~"399"

1201 B7	3211 B6	4221 A12	F254 G9
1202 G10	3212 B6	5201 B5	F255 C7
2201 A3	3213 B6	5202 B5	F256 B6
2202 B3	3214 B7	5203 B7	F257 E10
2203 D2	3215 B6	5204 D5	F258 C11
2204 C5	3216 A6	5205 D5	F262 F10
2205 G4	3217 B7	5206 D4	F263 F10
2206 G4	3218 B7	5207 D4	F264 F10
2207 F5	3219 B7	5208 D5	I201 A5
2208 G4	3220 B7	5209 D5	I202 B5
2209 G4	3221 A11	5210 D5	I203 B6
2210 B5	3222 B8	5211 E5	I204 B6
2211 B6	3223 B8	5212 E5	I205 B6
2212 B12	3224 B8	5213 E5	I206 A7
2213 B7	3225 B8	5214 G9	I207 C7
2214 B6	3226 B9	5215 F10	I208 B7
2216 B6	3227 C8	5216 F10	I209 C8
2218 A7	3228 D2	5217 H7	I210 C8
2219 A7	3229 C9	5218 F2	I211 B8
2220 B7	3230 B9	6201 E4	I212 B9
2221 A7	3231 B9	6204 C11	I213 C10
2222 E5	3232 B9	6205 C11	I214 C10
2223 B8	3233 B9	6206 C12	I215 C10
2224 C8	3234 B9	7201-1 B1	I216 C11
2225 B10	3235 B9	7201-2 C2	I218 D3
2226 C10	3236 B9	7202-1 C2	I219 C5
2227 B11	3237 C9	7202-2 C3	I220 D5
2228 C5	3238 B10	7203-1 C3	I221 D5
2229 C5	3239 B10	7203-2 C3	I222 D5
2230 D4	3240 B10	7204-1 A4	I223 D5
2231 D5	3241 B10	7204-2 A3	I224 E5
2232 D5	3242 C10	7205-1 B4	I225 C10
2233 D5	3243 C10	7205-2 B4	I226 F8
2234 D4	3244 D2	7206 B6	I227 F6
2235 D4	3245 C10	7207 B12	I228 F7
2236 D5	3246 C11	7208 D2	I229 F7
2237 D5	3247 B11	7209 D2	I230 F7
2238 E5	3248 C11	7210 D3	I231 F7
2239 E5	3249 B11	7211 F4	I232 F8
2240 E5	3250 D2	7212 G4	I233 F8
2241 E5	3251 D3	7213 G4	I234 F8
2242 E5	3252 D3	7216-1 G3	I235 F8
2243 E5	3253 D3	7216-2 G3	I236 F8
2244 E5	3254 F3	7217 C6	I237 F8
2245 E5	3255 E2	7218 F11	I238 F9
2246 F5	3256 E2	7219 F2	I239 F9
2247 F6	3257 E3	7220 A11	I240 F10
2248 G6	3258 E2	7221 A12	I241 B10
2249 G6	3259 E2	F201 B2	I242 F4
2250 F7	3260 E3	F202 B2	I243 C4
2251 F7	3261 A12	F203 B3	I244 B7
2252 F7	3262 F3	F204 B3	I246 D2
2253 F7	3263 F3	F205 B6	I247 D4
2254 F7	3264 F4	F206 B6	I248 D4
2255 F7	3265 F4	F207 C7	I254 F6
2256 F8	3266 F4	F208 C7	I255 F6
2257 F8	3267 F4	F209 B7	I256 F7
2258 G5	3268 F5	F210 F2	I257 E7
2259 G8	3270 F7	F211 C9	I258 E7
2260 F8	3271 F7	F212 C8	I259 F8
2262 G8	3272 F8	F213 C10	I262 F8
2263 F8	3273 F8	F214 B10	I264 F9
2264 G8	3274 F8	F215 B10	I265 F10
2265 G8	3275 F9	F216 C10	I266 F10
2266 G8	3276 F9	F217 B11	I267 F11
2267 F8	3277 F10	F218 B11	I268 G11
2268 G8	3278 F11	F219 C12	I269 C11
2269 F9	3279 G11	F220 D3	I270 B11
2270 F9	3280 E4	F221 D3	I271 B10
2271 F9	3281 F8	F222 D5	I272 B10
2272 F9	3282 F3	F223 D5	I273 C9
2273 F10	3283 B8	F224 D5	I274 A9
2274 F10	3284 B8	F225 D5	I275 A9
2275 G9	3285 G6	F226 D5	I277 C8
2276 G10	3286 H6	F227 D4	I278 C8
2277 F10	3287 B7	F228 E5	I283 B6
2278 F11	3288 B7	F229 E5	I284 B6
2279 F11	3289 D2	F230 G4	I285 B6
2280 A3	3290 B8	F231 G4	I288 B6
2281 B3	3291 F2	F232 F5	I289 A3
2282 F10	3292 F2	F233 F5	I290 A3
2283 F10	3293 G2	F234 F5	I291 A4
2284 F10	3294 G2	F235 F5	I292 B3
2285 F6	3295 F8	F236 F6	I293 B3
2286 F7	3296 B5	F237 F6	I294 B3
2287 H7	3297 A11	F238 F6	I297 B8
2288 H6	3298 A12	F239 F6	I298 C7
2290 F3	3299 B10	F240 F6	
2291 F2	3294 C9	F241 G7	
2292 E11	4205 C9	F242 G7	
2293 C10	4206 F3	F243 G7	
3201 A3	4207 E2	F244 F8	
3202 A4	4208 E2	F245 F9	
3203 A4	4209 E3	F246 F10	
3204 B3	4211 A4	F247 D11	
3205 B4	4212 B4	F248 F8	
3206 B4	4216 B9	F249 E11	
3207 B6	4217 B9	F250 A7	
3208 B6	4218 B9	F251 G9	
3209 B6	4219 B9	F252 G9	
3210 B6	4220 A11	F253 G9	

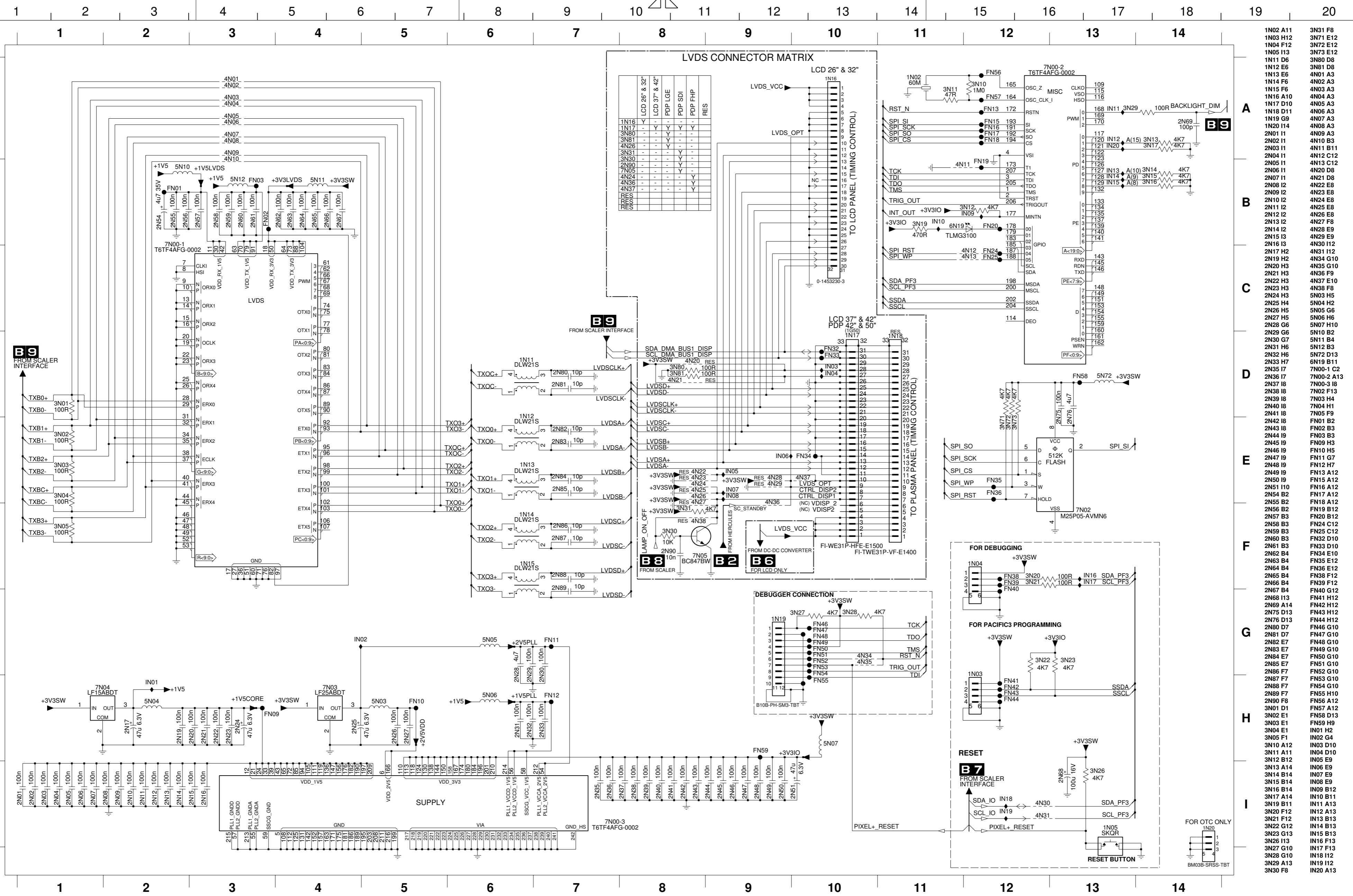

LVDS CONNECTOR MATRIX

Pin	Signal	Connector
1N16	Y	LCD 26" & 32"
1N17	Y	LCD 37" & 42"
3N80	Y	PDP LGE
3N81	Y	PDP SDI
4N26	Y	PDP FHP
3N81	Y	RES
3N30	Y	RES
2N90	Y	RES
7N05	Y	RES
4N24	Y	RES
4N36	Y	RES
4N37	Y	RES
4N25	Y	RES
4N27	Y	RES
4N28	Y	RES
4N29	Y	RES
4N30	Y	RES
4N31	Y	RES
4N32	Y	RES
4N33	Y	RES
4N34	Y	RES
4N35	Y	RES
4N38	Y	RES
4N39	Y	RES
4N40	Y	RES
4N41	Y	RES
4N42	Y	RES
4N43	Y	RES
4N44	Y	RES
4N45	Y	RES
4N46	Y	RES
4N47	Y	RES
4N48	Y	RES
4N49	Y	RES
4N50	Y	RES
4N51	Y	RES
4N52	Y	RES
4N53	Y	RES
4N54	Y	RES
4N55	Y	RES
4N56	Y	RES
4N57	Y	RES
4N58	Y	RES
4N59	Y	RES
4N60	Y	RES
4N61	Y	RES
4N62	Y	RES
4N63	Y	RES
4N64	Y	RES
4N65	Y	RES
4N66	Y	RES
4N67	Y	RES
4N68	Y	RES
4N69	Y	RES
4N70	Y	RES
4N71	Y	RES
4N72	Y	RES
4N73	Y	RES
4N74	Y	RES
4N75	Y	RES
4N76	Y	RES
4N77	Y	RES
4N78	Y	RES
4N79	Y	RES
4N80	Y	RES
4N81	Y	RES
4N82	Y	RES
4N83	Y	RES
4N84	Y	RES
4N85	Y	RES
4N86	Y	RES
4N87	Y	RES
4N88	Y	RES
4N89	Y	RES
4N90	Y	RES
4N91	Y	RES
4N92	Y	RES
4N93	Y	RES
4N94	Y	RES
4N95	Y	RES
4N96	Y	RES
4N97	Y	RES
4N98	Y	RES
4N99	Y	RES
4N100	Y	RES

- 1N02 A11
- 1N03 F12
- 1N04 F12
- 1N05 I13
- 1N11 D6
- 1N12 E6
- 1N13 E6
- 1N14 F6
- 1N15 F6
- 1N16 A10
- 1N17 D10
- 1N18 D11
- 1N19 G9
- 1N20 I14
- 2N01 I1
- 2N02 I1
- 2N03 I1
- 2N04 I1
- 2N05 I1
- 2N06 I1
- 2N07 I1
- 2N08 I2
- 2N09 I2
- 2N10 I2
- 2N11 I2
- 2N12 I2
- 2N13 I2
- 2N14 I2
- 2N15 I3
- 2N16 I3
- 2N17 H2
- 2N19 H2
- 2N20 H3
- 2N21 H3
- 2N22 H3
- 2N23 H3
- 2N24 H5
- 2N25 H4
- 2N26 H5
- 2N27 H5
- 2N28 G6
- 2N29 G6
- 2N30 G7
- 2N31 H6
- 2N32 H6
- 2N34 H5
- 2N35 I7
- 2N36 I7
- 2N37 I8
- 2N38 I8
- 2N39 I8
- 2N40 H1
- 2N41 I8
- 2N42 I8
- 2N43 I8
- 2N44 I9
- 2N45 I9
- 2N46 I9
- 2N47 I9
- 2N48 I9
- 2N49 I9
- 2N50 I9
- 2N51 I10
- 2N52 B2
- 2N53 B2
- 2N54 B2
- 2N55 B2
- 2N56 B2
- 2N57 B3
- 2N58 B3
- 2N59 B3
- 2N60 B3
- 2N61 B3
- 2N62 B4
- 2N63 B4
- 2N64 B4
- 2N65 B4
- 2N66 B4
- 2N67 B4
- 2N68 I13
- 2N69 A14
- 2N75 D13
- 2N76 D13
- 2N80 D7
- 2N81 D7
- 2N82 E7
- 2N83 E7
- 2N84 E7
- 2N85 E7
- 2N86 F7
- 2N87 F7
- 2N88 F7
- 2N89 F7
- 2N90 F8
- 3N01 D1
- 3N02 E1
- 3N04 E1
- 3N05 F1
- 3N10 A12
- 3N11 A11
- 3N12 B12
- 3N13 A14
- 3N14 B14
- 3N15 B14
- 3N16 B14
- 3N17 A14
- 3N19 B11
- 3N20 F12
- 3N21 F12
- 3N22 G12
- 3N23 G13
- 3N26 I13
- 3N27 G10
- 3N28 G10
- 3N29 A13
- 3N30 F8
- 3N31 F8
- 3N72 E12
- 3N73 E12
- 3N80 D8
- 3N81 D8
- 4N01 A3
- 4N02 A3
- 4N03 A3
- 4N04 A3
- 4N05 A3
- 4N06 A3
- 4N07 A3
- 4N08 A3
- 4N09 A3
- 4N10 B3
- 4N11 B11
- 4N12 C12
- 4N13 C12
- 4N20 B8
- 4N21 D8
- 4N22 E8
- 4N23 E8
- 4N24 E8
- 4N25 E8
- 4N26 E8
- 4N27 F8
- 4N28 E9
- 4N29 E9
- 4N30 I12
- 4N31 I12
- 4N34 G10
- 4N35 G10
- 4N36 F9
- 4N37 E10
- 4N38 F8
- 4N39 H7
- 4N40 H2
- 4N41 H2
- 4N42 H2
- 4N43 H2
- 4N44 I9
- 4N45 I9
- 4N46 I9
- 4N47 I9
- 4N48 I9
- 4N49 I9
- 4N50 I9
- 4N51 I10
- 4N52 B2
- 4N53 B2
- 4N54 B2
- 4N55 B2
- 4N56 B2
- 4N57 B3
- 4N58 B3
- 4N59 B3
- 4N60 B3
- 4N61 B3
- 4N62 B4
- 4N63 B4
- 4N64 B4
- 4N65 B4
- 4N66 B4
- 4N67 B4
- 4N68 I13
- 4N69 A14
- 4N75 D13
- 4N76 D13
- 4N80 D7
- 4N81 D7
- 4N82 E7
- 4N83 E7
- 4N84 E7
- 4N85 E7
- 4N86 F7
- 4N87 F7
- 4N88 F7
- 4N89 F7
- 4N90 F8
- 4N91 D1
- 4N92 E1
- 4N94 E1
- 4N95 F1
- 4N96 D10
- 4N97 D10
- 4N98 D10
- 4N99 D10
- 4N100 B12
- 4N101 E9
- 4N102 E9
- 4N103 E9
- 4N104 E9
- 4N105 E9
- 4N106 E9
- 4N107 E9
- 4N108 E9
- 4N109 B12
- 4N110 B11
- 4N111 A13
- 4N112 F12
- 4N113 B13
- 4N114 B13
- 4N115 B13
- 4N116 F13
- 4N117 F13
- 4N118 I12
- 4N119 I12
- 4N120 A13



SSB SCART LC04SD2.1 MULTIPLE 12NC - 3139_123_61163_01 / 3139_123_61241_02
 SSB SCART LC04SD2.1 SINGLE 12NC - 3139_123_61173_01 / 3139_123_61251_02
 CELL 12NC - 8239_125_12163

"N00"~"N99"
 "P00"~"P99"

SA1 CONNECTIONS

SA1

A

A

B

B

C

C

D

D

E

E

F

F

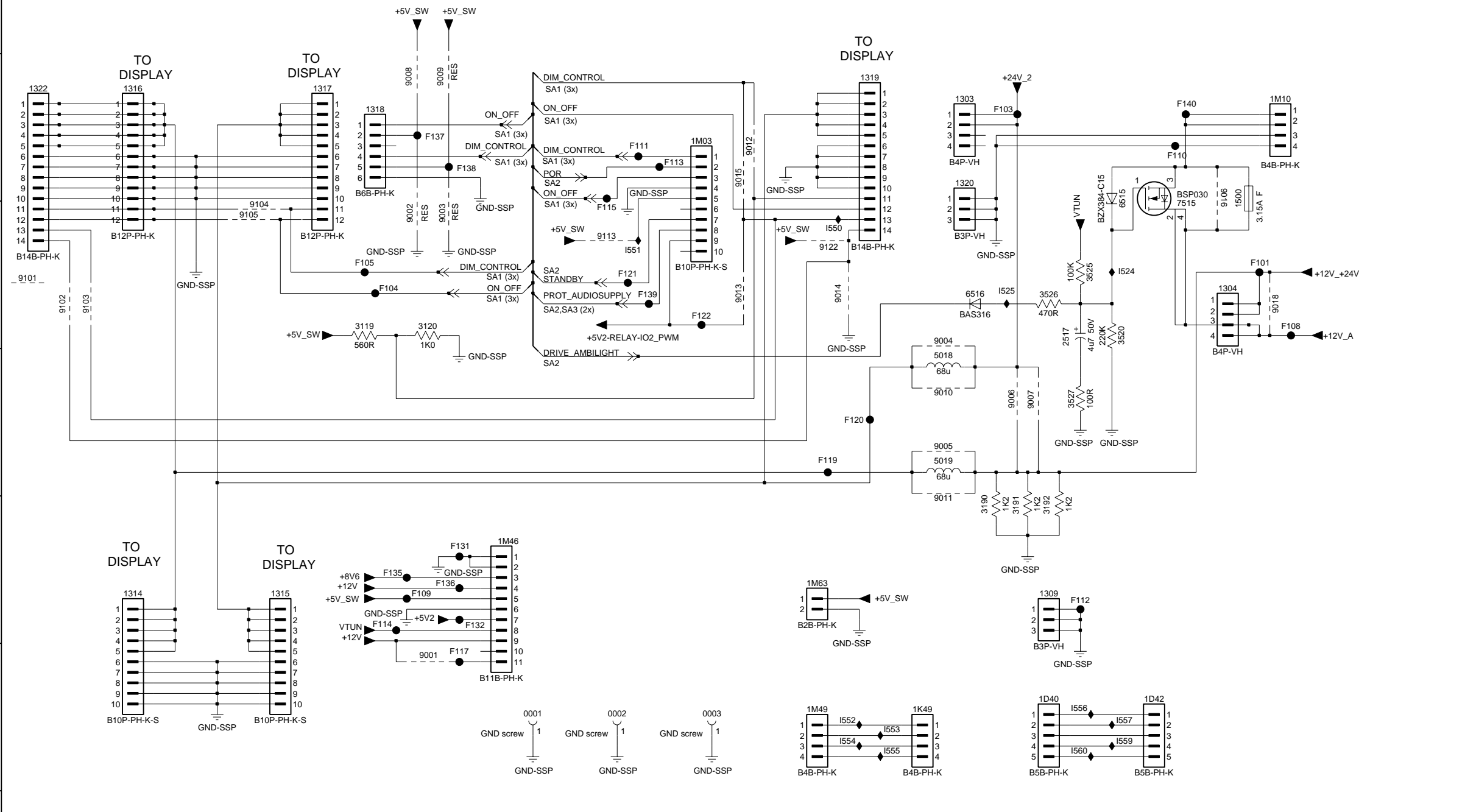

0001 F4	F120 D6
0002 F4	F121 C4
0003 F5	F122 C5
1303 B7	F131 E3
1304 C8	F132 E3
1309 E7	F135 E3
1314 E1	F136 E3
1315 E2	F137 B3
1316 B1	F138 B3
1317 B2	F139 C4
1318 B3	F140 B8
1319 B6	I524 C8
1320 B7	I525 C7
1322 B1	I550 C6
1D40 F7	I552 F6
1D42 F8	I553 F6
1K49 F6	I554 F6
1M03 B5	I555 F6
1M10 B9	I556 F7
1M46 E4	I557 F8
1M49 F6	I559 F8
1M63 E6	I560 F7
2517 C7	
3119 C2	
3120 C3	
3190 E7	
3191 E7	
3192 E7	
3520 C8	
3525 C7	
3526 C7	
3527 D7	
5018 D6	
5019 D6	
6515 B8	
6516 C7	
7515 B8	
9001 F3	
9002 C3	
9003 C3	
9004 C6	
9005 D6	
9006 D7	
9007 D7	
9008 B3	
9009 B3	
9010 D6	
9011 E6	
9012 B5	
9013 C5	
9014 C6	
9015 B5	
9016 B8	
9018 C9	
9101 C1	
9102 C1	
9103 C1	
9104 C2	
9105 C2	
9113 C4	
9122 C6	
F101 C9	
F103 B7	
F104 C3	
F105 C2	
F108 C9	
F109 E3	
F110 B8	
F111 B4	
F112 E7	
F113 B5	
F114 E3	
F115 C4	
F117 F3	
F119 D6	

A

A

B

B

C

C

D

D

E

E

F

F

G

G

H

H

I

I

HOT GROUND

COLD GROUND

HOT GROUND

COLD GROUND

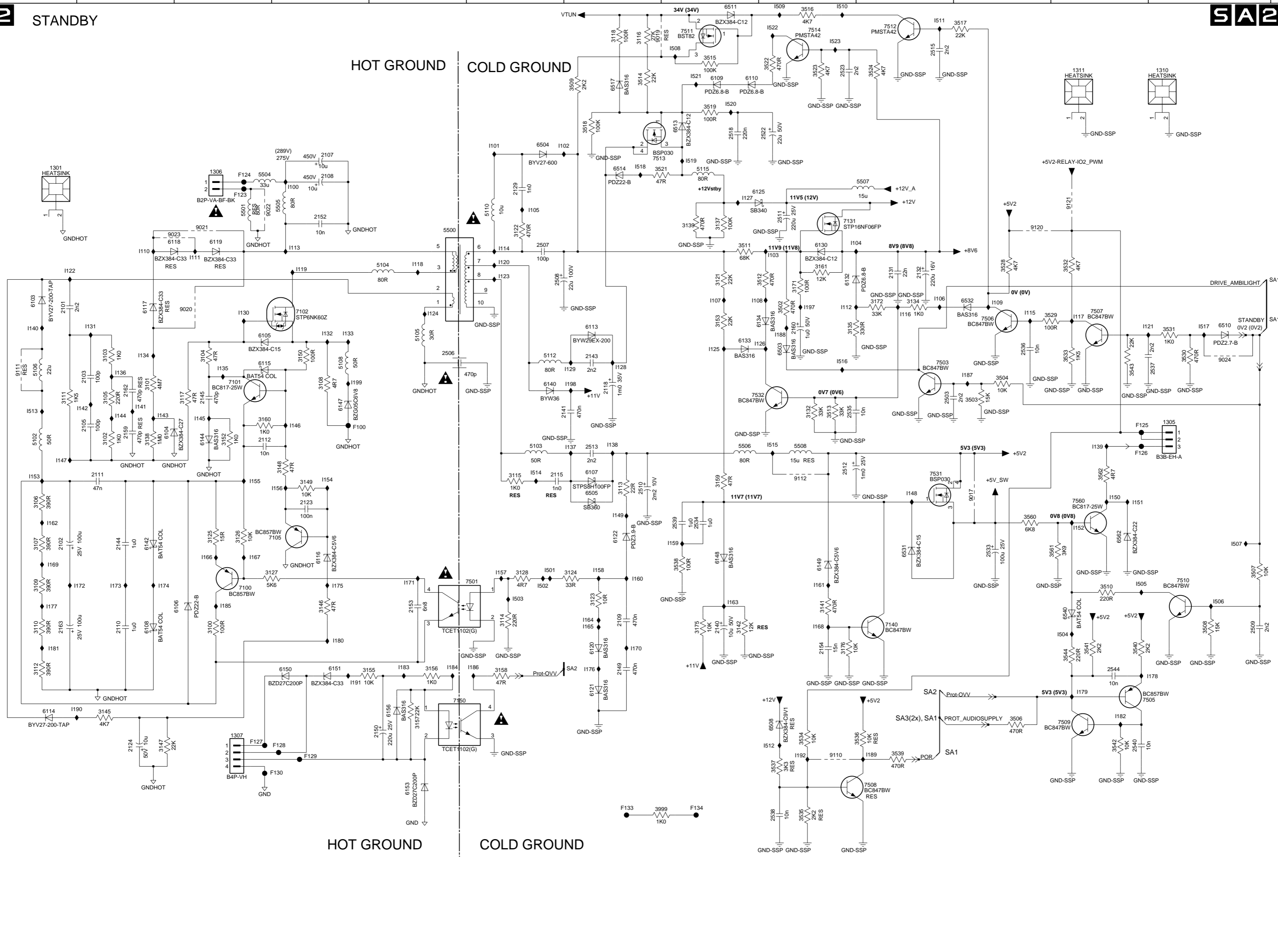

1301 B1	3506 G11	7511 A8	1186 G6
1305 D13	3507 F13	7512 A10	1187 D11
1306 B3	3508 G13	7513 B7	1188 D9
1307 H3	3509 A7	7514 A9	1189 H10
1310 A13	3510 F12	7515 E10	1190 G1
1311 A12	3511 C8	7532 D9	1191 G4
2101 C1	3512 C9	7560 E12	1192 H9
2102 F1	3513 D9	9017 E11	1197 C9
2103 D2	3514 A7	9019 A7	1198 D7
2105 D2	3515 A8	9020 C3	1199 D4
2107 B4	3516 A9	9021 B3	1501 F6
2108 B4	3517 A11	9022 B3	1502 F6
2109 F7	3518 A7	9023 C2	1503 F6
2110 G2	3519 A8	9024 D13	1504 G12
2111 E2	3521 B7	9110 H9	1505 F12
2112 E3	3522 A9	9111 D1	1506 F13
2115 E6	3523 A9	9112 E9	1507 F13
2118 D7	3524 A10	9120 B11	1508 A8
2123 E4	3528 C11	9121 B12	1509 A9
2124 H2	3529 C11	F100 D4	1510 A9
2129 B6	3530 D13	F123 B3	1511 A10
2131 C10	3531 C13	F124 B3	1512 H9
2132 C10	3532 C12	F125 D12	1513 D1
2140 G8	3533 D12	F126 E12	1514 E6
2141 D7	3534 H9	F127 H3	1515 E9
2143 D7	3535 H9	F128 H4	1516 D9
2144 F2	3536 H10	F129 H4	1517 C13
2145 D3	3537 H9	F130 H4	1518 B7
2149 G7	3538 F8	F133 H7	1519 B8
2150 H5	3539 H10	F134 H8	1520 A8
2152 B4	3540 G12	I100 B4	1521 A8
2153 F5	3541 G12	I101 B6	1522 A9
2154 G9	3542 H12	I102 B6	1523 A9
2159 E2	3543 D12	I103 C9	
2160 C9	3544 G12	I104 C9	
2162 D9	3545 E11	I105 B6	
2163 G1	3561 F12	I106 C10	
2503 D10	3562 E12	I107 C8	
2506 D5	3999 H7	I108 C8	
2507 C6	5102 E1	I109 C11	
2508 C6	5103 E6	I110 C2	
2509 G13	5104 C5	I111 C3	
2510 E7	5105 D5	I112 C9	
2511 B9	5106 D1	I113 C4	
2512 E9	5108 D4	I114 C6	
2513 E7	5110 B6	I115 C11	
2515 A10	5112 D6	I116 C10	
2518 A8	5115 B8	I117 C12	
2522 A9	5500 B5	I118 C5	
2523 A9	5501 B3	I119 C4	
2533 F11	5504 B3	I120 C6	
2534 E8	5505 B4	I121 C12	
2535 D9	5506 E8	I122 C1	
2536 D11	5507 B10	I123 C6	
2537 D13	5508 E9	I124 C5	
2538 H9	6103 C1	I125 D8	
2539 E8	6104 E2	I126 D9	
2540 H12	6105 D3	I127 B8	
2544 G12	6106 F2	I128 D7	
3100 G3	6107 E7	I129 D7	
3101 D2	6108 G2	I130 C3	
3102 E2	6109 A8	I131 C2	
3103 D2	6110 A8	I132 D4	
3104 D3	6113 C7	I133 D4	
3105 D2	6114 G1	I134 D2	
3106 E1	6115 D3	I135 D3	
3107 F1	6116 F4	I136 D2	
3108 D4	6117 C2	I137 E7	
3109 F1	6118 C2	I138 E7	
3110 G1	6119 C3	I139 E12	
3111 D1	6120 G7	I140 C1	
3112 G1	6121 G7	I141 D2	
3113 E7	6122 F7	I142 D2	
3114 F6	6125 B8	I143 D2	
3115 E6	6130 C9	I144 D2	
3116 A7	6132 C9	I145 D3	
3117 D3	6133 D8	I146 D4	
3118 A7	6134 C9	I147 E1	
3122 B6	6140 D6	I148 E10	
3123 F7	6142 F2	I149 E7	
3124 F7	6144 C3	I150 E12	
3125 F3	6147 D4	I151 E12	
3126 F3	6148 F8	I152 E12	
3127 F3	6149 F9	I153 E1	
3128 F6	6150 G4	I154 E4	
3132 D9	6151 G4	I155 E3	
3134 C10	6153 H5	I156 E4	
3135 C9	6156 G5	I157 F6	
3137 B8	6503 D9	I158 F7	
3139 B8	6504 B6	I159 F8	
3139 B8	6505 E7	I160 F7	
3140 C8	6508 H9	I161 F9	
3141 F9	6510 C13	I162 E1	
3142 G8	6511 A8	I163 F8	
3145 G2	6513 A8	I164 F7	
3146 F4	6514 B7	I165 G7	
3147 H2	6517 A7	I166 F3	
3148 E4	6531 F10	I167 F3	
3149 E4	6532 C11	I168 G9	
3150 D4	6540 F12	I169 F1	
3152 C3	6562 F12	I170 G7	
3153 C8	7100 F3	I171 F5	
3155 G4	7101 D3	I172 F2	
3156 G5	7102 C4	I173 F2	
3157 G5	7105 F4	I174 F2	
3158 G6	7131 B9	I175 F4	
3159 E8	7140 G10	I176 G7	
3160 D3	7150 G5	I177 F1	
3161 C9	7501 F6	I178 G13	
3171 C9	7503 D10	I179 G12	
3172 C10	7505 G12	I180 G4	
3175 G8	7506 C11	I181 G1	
3176 G9	7507 C12	I182 G12	
3502 C9	7508 H10	I183 G5	
3503 D11	7509 H12	I184 G5	
3504 D11	7510 F13	I185 F3	